

An Easier and More Efficient Way to Keep your LEDs Running Brighter, Longer!

A high-level overview of power trends in the High Power LED market

By: Chester Firek
Sr. Product Marketing Manager, Vicor



Direct-view LED video wall technology is becoming an increasingly popular choice for large-scale displays because of its superior brightness as compared to LCD technology. However, large video displays present a power design challenge—how best to develop an efficient solution that reduces energy losses, minimizes heat generation and is easily scalable? Heat can be a big problem with LEDs. More heat results in excessive temperatures, which rapidly degrades LED luster and longevity.

One factor contributing to the heating of a LED panel is the heat losses in converting and distributing power within the video wall; losses both from the power converters and the resistive copper losses in cabling and the printed circuit board. So what’s the solution? Evaluating the merits of different partitioning options will help identify the best option when designing high-powered LED application.

Figure 1: What happens in Vegas... the Fremont Street Experience LED display has 7,552 x 552 pixel resolution with a 2" pixel spacing and consumes 2.2 MW at full brightness. With 12.5 million LEDs, it measures 1,500' x 90'
(Image courtesy of Indianapolis Museum of Art)



Not Your Average LED Power Requirements

In addition to being brighter, direct-view LED displays are considerably more power-efficient than LED backlit LCD displays because they can produce more light output using less energy (i.e., “useful power”). Nonetheless, they still generate a significant amount of “wasted power” in the form of heat. This may seem surprising as LEDs are typically cool to the touch. That’s because they don’t generally produce heat in the form of infra-red radiation, which is detectable by touch. In fact, up to 85% of the energy consumed is dissipated as heat so large-scale LED arrays demand significant power in excess of that converted to light.

For large LED panels the LED power dissipation can become significant. For example, the Fremont Street Experience display (Figure 1) consumes 2.2 MW at full brightness, and requires even more energy by day to combat the effects of sunlight. Even small displays have large numbers of LEDs and consume significant power: for example, a display module from one leading manufacturer contains an array of 80 x 80, i.e. 6,400 total LEDs and requires 300W (5V, 60A).

Maximizing efficiency is, therefore, essential in the design of an LED power supply.

Today's Expanding Array of LEDs

Large LED arrays composed of multiple panels can provide seamless images of any size or shape, with excellent viewing characteristics from all angles. Examples range in size from a simple scrolling message display to displays like the Fremont Street Experience shown in Figure 1, with 12.5 million LEDs. Figure 2 shows two display examples where LED technology has unique advantages: a taxi-mounted LED advertising display and a highly-curved display around the side of a building.



(A)

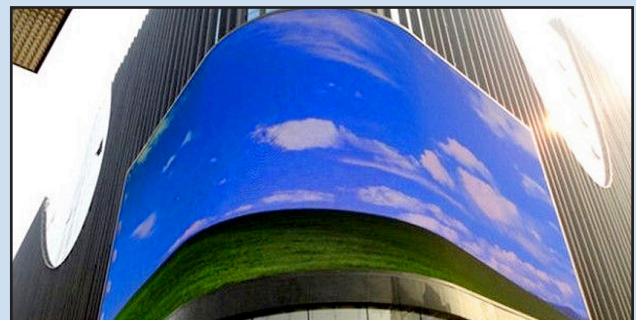

(B)

Figure 2: LED displays can change in response to real-time vehicle location information (A) or conform to three-dimensional shapes (B)

(Image source: Vicor and commercialledscreens.com)

Power System Design Priorities

The power supply system must convert incoming AC voltage to isolated low voltage, high current DC in the most efficient way. Each stage of power conversion adds cost and wastes energy, so minimizing the number of stages is a design priority.

Large video walls are composed of many modules linked together, so an efficient design must also scale well with minimum duplication of power conversion stages.

What are two of the key design priorities?

1. Minimizing distribution losses – Transmitting power from the power supplies to the LED array over resistive wires incurs power losses in the form of heat, known as distribution losses. The distribution loss for a current (I) is proportional to the square of the current and is given by $P = I^2R$, where R is the resistance of the wire, bus bar or PCB trace; reducing it requires either reducing the current or reducing the resistance of the wire.

Reducing the current while delivering the same total power to the load requires increasing the voltage ($P = VI$). Doubling the voltage, from 24 to 48V for example, reduces the current by 50%, which in turn reduces the distribution loss by 75%.

Attempting to achieve the same result by reducing the wire resistance requires quadrupling the conductor cross-section area, which adds weight and cost, and is not very practical.

2. Reducing heating effect on LEDs – As we've already discussed, heat is the enemy of LEDs and inefficiencies in the power design can only make matters worse. Excessive heat shortens the useful life of an LED and causes discoloration. Even worse, the light output declines with increasing junction temperature; an efficient power supply system for LED use must pay attention to each individual component to avoid local hotspots, which can result in LEDs that not only fail faster, but look dimmer throughout their operating life. This is especially critical in a video wall where not only light quality but uniformity is important.

Figure 3: Relative light output vs. junction temperature of different-colored LEDs
(Image source: RPI/LumiLeds)

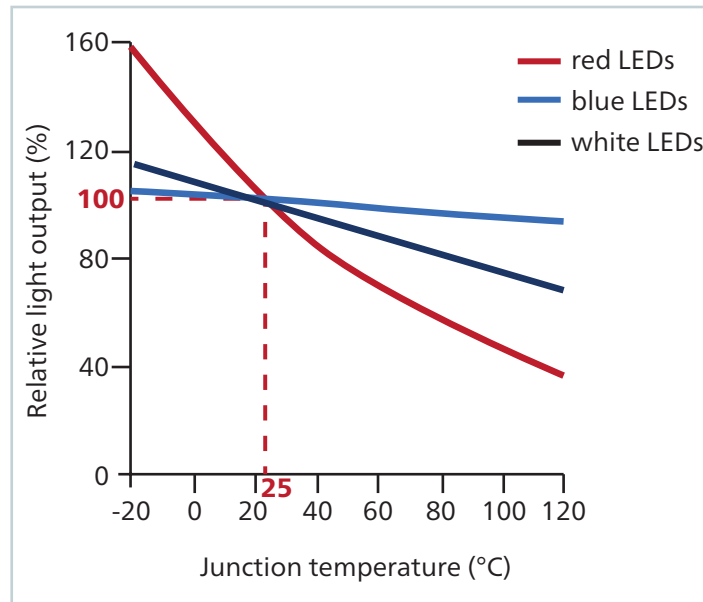

A simple way to improve power system efficiency is to minimize the number conversion stages. For example, removing a conversion stage can improve system efficiency by 5-10%, and depending on the power level can reduce the amount of heat generated into the system. To eliminate a conversion stage a designer needs to select components that can offer high step-down conversion ratios without compromising efficiency.

Power System Components Make the Difference

There are a number of ways to partition a power supply system to convert AC mains to low voltage DC for the LED drivers and control circuits. No matter which particular partition is selected, a typical design will include the following blocks:

- input protection provided by a Thermally-protected Metal Oxide Varistor (TMOV) or similar device
- an AC filtering rectification block
- a bulk AC-DC conversion block including power factor correction (PFC) to maximize the power available from the AC mains, and adhere to strict equipment power factor requirements
- point-of-load (PoL) DC-DC buck regulation to generate the final tightly regulated voltage rails.

For example (Figure 4), Vicor offers a comprehensive portfolio of products to simplify the design of power supplies for large-scale video walls. The result is a simple design that minimizes conversion stages and requires few external components.

Figure 4: A mixed-voltage AC-DC power system partitioning. The PFM outputs the intermediate bus voltage to PoL converters at each panel. (Image Source: Vicor)

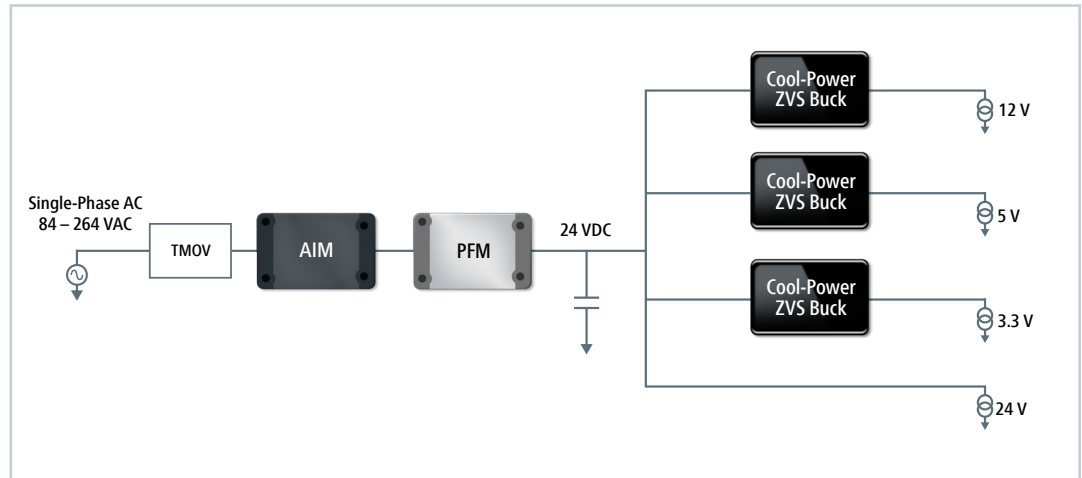

Building Blocks to an Efficient Power Design

Vicor structures a high-efficiency approach for high-powered LEDs as follows:

AC Input Stage – The AC Input Front-End Module (AIM™) performs line rectification, EMI/RFI filtering, transient protection and inrush limiting to provide a non-isolated, rectified AC line voltage to subsequent stages.

AC-DC Conversion – The PFM™ family comprises isolated & regulated AC-DC converters with PFC for AC-DC systems. The AIM/PFM combination is capable of converting a universal AC to an isolated 48V or 24V with efficiency of up to 92% for systems up to 400W; in a form-factor smaller than an average smartphone (Figure 5). The family features a double-sided thermal housing with chassis or board mounting options.

Figure 5: Standard smartphone next to a PFM, 4414 VIA.



DC-DC Buck Conversion – Cool-Power® is a family of high input-voltage, wide input-range DC-DC Zero-Voltage Switching (ZVS) buck regulators that integrate controller, power switches, and support components into a single package. The ZVS topology enables megahertz switching frequencies which reduces gate drive losses and body diode conduction losses; Cool-Power ZVS regulators can operate from either 12V, 24V or 48V inputs and achieve efficiencies of over 97.5% and requires only an external inductor, and minimal capacitors to form a complete DC-DC buck regulator solution.

Identifying the Optimal Power Solution

Using the building blocks previously mentioned, there are several possible system partitions for an LED video wall.

Large panel displays, composed of multiple smaller panels, need to be capable of being powered off a common bus voltage. Distributing AC directly to each panel and converting the AC to DC conversion on each panel would be too costly, too bulky, and is generally not an option for safety reasons. Instead, a single bulk AC-DC converter stage is typically used to supply an isolated low voltage bus voltage to power each individual panel. With large panels, the distance from the bulk AC-DC supply to the LED drivers can be many meters in length, which creates challenges as power levels increase.

What are the Options for the Intermediate DC Bus Voltage?

24V and 12V power distribution have been the most commonly used bus voltages for LED panels. Compared to distribution AC, it removes potentially lethal voltages from the panels and they meet the SELV (Safety Extra Low Voltage) “safe” voltage level for low voltage power supplies.

However, a superior option to 12V or 24V is to double the intermediate voltage to 48V (Figure 6). Since 48V is below 60V it still meets the SELV criteria, even including an overvoltage protection allowance of 20%. Compared to a 24V system, this cuts the currents by half for a given power level and reduces cable cost and weight — more savings!

It also cuts distribution losses by 75%, which reduces heat generation. A lower operating temperature improves system reliability, and lower current reduces the thickness of the LED panels. Busing a higher voltage with lower distribution losses also allows the video wall to be more efficient which reduces the lifetime operating costs for the end user.

Options for Generating a 48V-Based Design

Generating an isolated 48V bus to distribute can be very simple, in addition to the AC input PFM™ a high powered 3-phase AC-DC converter could be followed by a Vicor Bus Converter Module (BCM™) to convert 380V to an isolated 48V with peak efficiency up to 98%. A single high voltage BCM is capable of 1.75 kW of power delivery within 63x22 mm size, 2,735 W/in³ power density. Either 48V solution can then be followed by a 48V input Cool-Power buck or buck-boost regulators to directly power LEDs or LED drivers.

Figure 6: 48V power system architecture (Image source: Vicor)

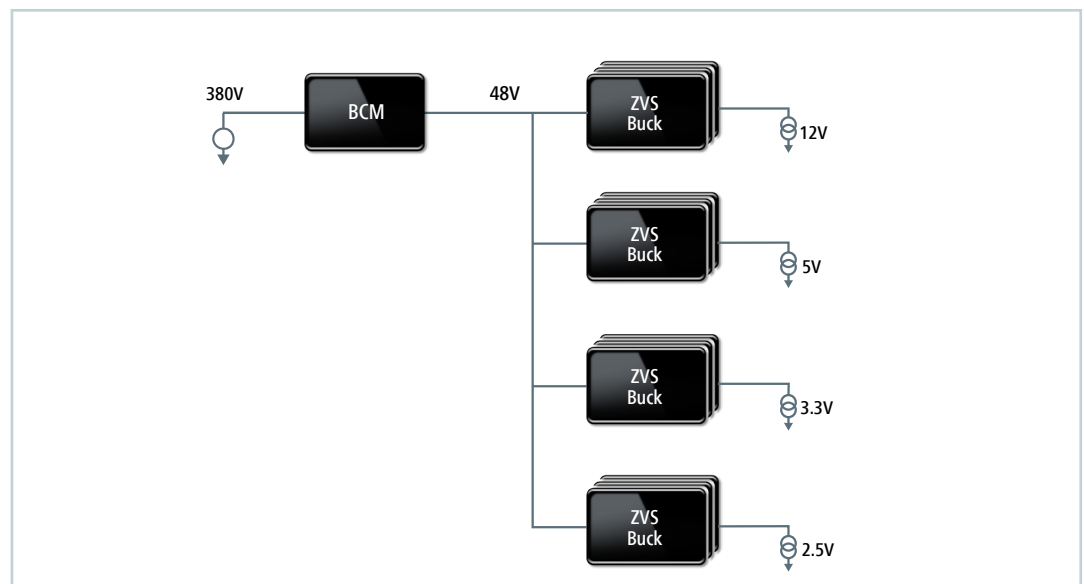

48V Delivers What 24V Cannot

So how do you deliver brighter LEDs that last longer?

You explore the merits of several approaches first. Driving thousands of LEDs in a large-scale video display requires an efficient power system to produce the low-voltage, high-current supply needed. Traditionally designers have turned to a PoL solution that uses 24V as the intermediate DC voltage. Increasing the voltage to 48V, though, reaps numerous benefits that 24V just can't deliver:

1. reduced heat generation / easier thermal management
2. reduced cabling / save costs, size and weight
3. increased LED performance / improved display quality
4. longer panel life / improved reliability
5. higher power efficiency / lower power usage

To safeguard your next large-format LED display deployment — keeping them brighter, longer — start with 48V.

Vicor in LED

Vicor's modular power system components help designers easily assemble configurable, high-density LED power supply systems that are highly efficient. Because the component system is inherently flexible, it works for virtually any power level, size or form factor, with minimum effort. By combining flexible, high-efficiency building blocks with intuitive online design tools and easy-to-use development kits, designers can optimize power system designs with speed and ease.



**Start your LED system design now using
Vicor's Power System Designer.**