



**MX150L™ Sealed
Connector System**





MX150L™ Sealed Connector System

The pre-assembled, submersible MX150L is a high performance connector system suitable for challenging, rugged and harsh applications.

The MX150L sealed connector system is designed to meet the need for a rugged, environmentally sealed connector system supporting both low-level signal applications as well as power applications up to 40.0A, from marine applications to off-road construction equipment applications. The system is comprised of wire-to-wire, wire-to-panel and wire-to-board configurations.

These innovative mat-sealed connectors are based upon the 1.50 and 2.50mm (.059 and .098") blade-type terminals. This design eliminates the need to purchase, handle and crimp individual wire seals to lower applied cost. The mat-seal design is a single silicone-based seal with individual wire openings and a seal cap to protect, securely retain, and provide strain relief to the seal. The cost-effective connector design features all-in-one plug and receptacle housings with pre-assembled mat-wire and interfacial connector seals. Integral Terminal Position Assurance (TPA) and optional Connector Position Assurance (CPA) components eliminate

time-consuming and costly assembly operations. Completing the application is as simple as crimping the appropriate terminal, inserting the crimped terminal lead and seating the TPA to its final locked position. No additional components are required.

Tooling solutions include FineAdjust™ crimp press applicators for high-volume production, as well as hand tools for low-volume production and field repairs.

FEATURES AND BENEFITS

- Pre-assembled connector housings, seals, TPA components and mat-seal cap shipped in one piece to provide applied labor and cost savings
- Audible and tactile clicks on insertion, extraction and mating feedback facilitates reliable mating and terminal loading and removal
- Integral TPA assures that crimped terminal leads are properly locked into connector (TPA will not seat into final lock position and connector system will not latch if terminal is not locked properly into position)
- Unused circuits can be blocked using plastic seal plugs, which facilitates flexibility of sealing unused circuits without adding complexity to part numbers and customer inventory
- Conforms to UL 1977, which allows for a UL recognized sealed connector system for use in data, signal, control and power applications
- Integral locking latch with secondary, pre-loaded CPA option assures that connector system is properly latched. CPA will not move to final locked position if connector is not latched. Confirms positive mating of connector
- Superior electrical and mechanical performance capabilities surpass performance of most mature competitive products in market
- Sealed panel mount plugs are equipped with a blind hole boss feature which reduces extra hardware while improving the sealing process during assembly by eliminating a leak path
- Integral, 2-way mat and interface seals designed and tested to IEC IP 67 standards exceeds "waterproof" demands as a true sealed connector system tested under submersed conditions in various fluids
- Easy terminal insertion and extraction provides quick, low-cost field repairs using common screw driver, needle nose pliers and terminal extraction tool
- Protective mat-seal cap protects, securely retains, and provides strain relief to wire seal interface
- Simple crimp, poke and plug application eliminates need to crimp individual wire seals

MX150L SEALED CONNECTOR SYSTEMS - EXPLODED VIEW

Receptacle Connector

Plug Connector

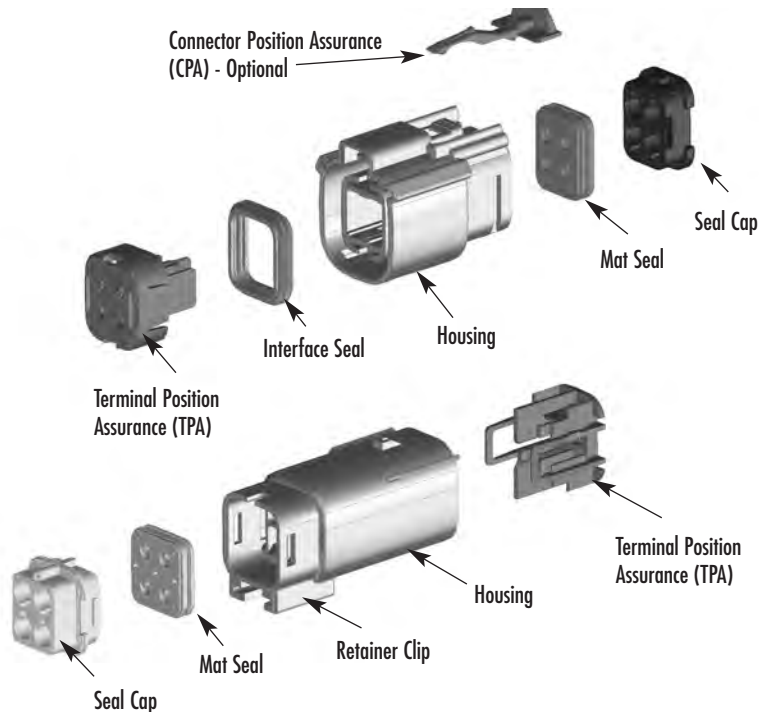

NOTE: All discrete components shown above for both the receptacle and plug housings are pre-assembled. Terminals are simply crimped and poked into the housings. No additional wire seals, wedge locks or CPA locks are required.



MX150L™

Product Overview

14 TO 22 AWG WIRE-TO-WIRE, PANEL MOUNT AND PCB

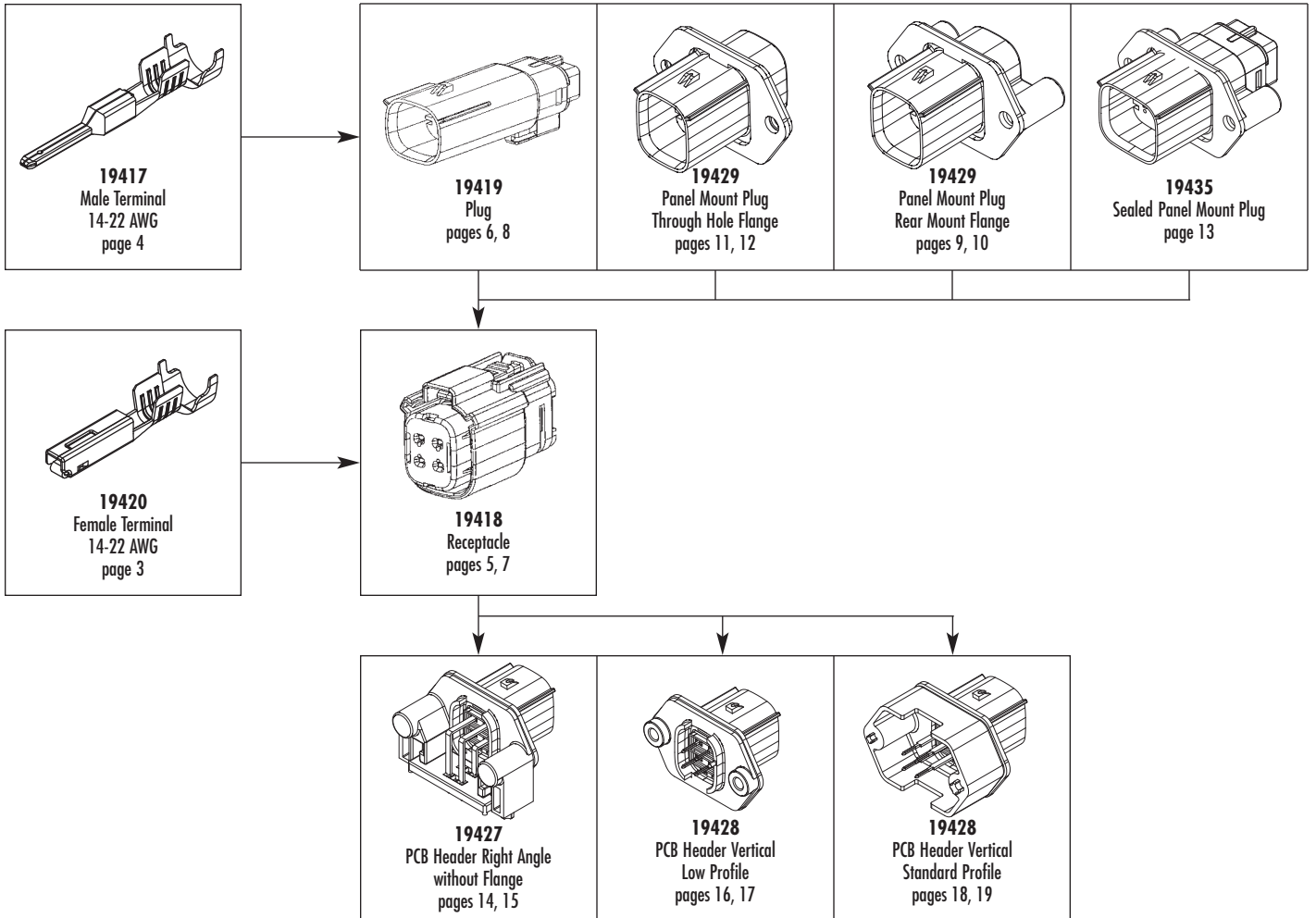

8, 10 AND 12 AWG WIRE-TO-WIRE

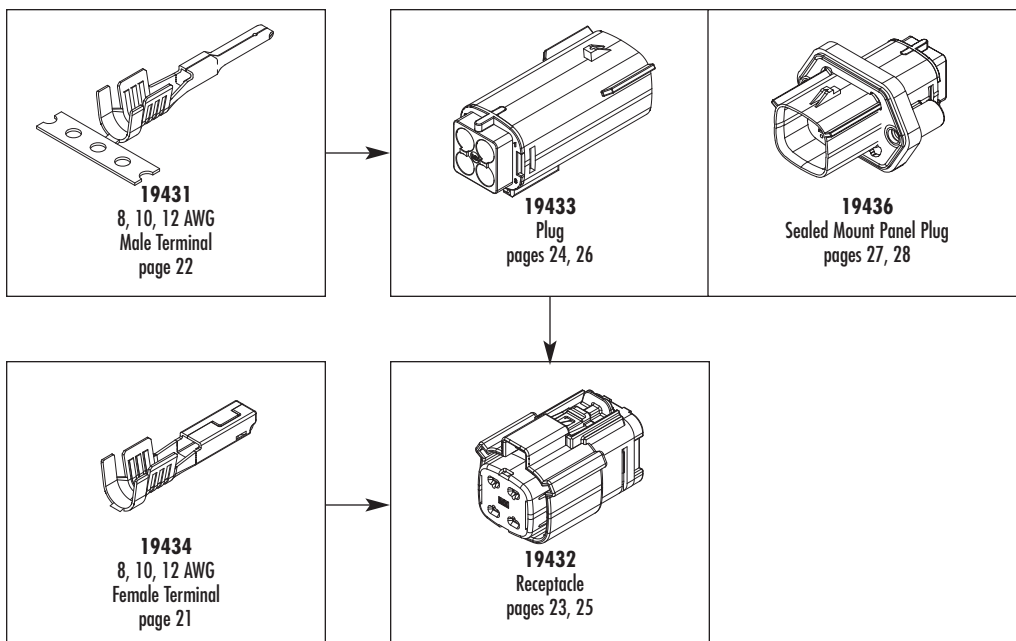

FEATURES AND SPECIFICATIONS

Features and Benefits

- Mat seal friendly design features center seam and coined edges
- Anti-over stress beam geometry feature
- Low insertion force

Reference Information

UL File No.: E152602
 Designed In: Inches
 Used With: 19418

Electrical

Current: 18.0A

Physical

Contact: Copper Alloy
 Plating: Tin or Gold

Mechanical

Contact Insertion Force: 1.0 lb. max.
 Durability: Tin Plating—25 cycles
 Gold Plating—100 cycles



5.84mm (.230") Pitch
MX150L™
Terminal

19420

Female

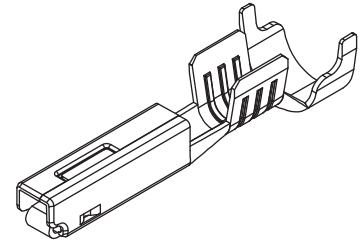

CATALOG DRAWING (FOR REFERENCE ONLY)

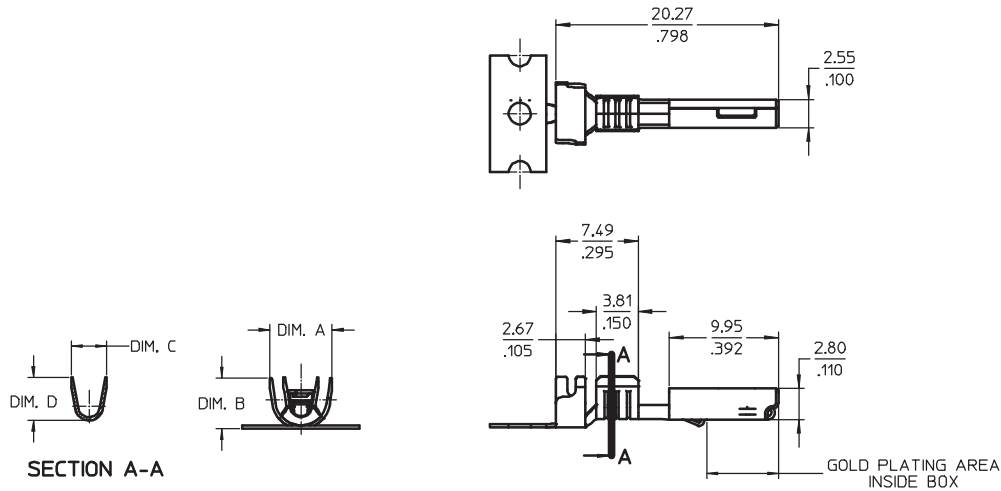

ORDERING INFORMATION

Wire Range (AWG)	Insulation Diameter mm (In)	Order No.				Dimension			
		Pre-Tin		Gold		A	B	C	D
		Strip	Loose	Strip	Loose				
18-22	2.36-2.74 (.093-.108)	19420-0002	19420-0010	19420-0004	19420-0012	4.60 (.181)	3.63 (.143)	2.50 (.098)	2.70 (.106)
14-16	2.87-3.53 (.113-.139)	19420-0001	19420-0009	19420-0003	19420-0011	5.66 (.223)	4.62 (.182)	3.58 (.141)	3.94 (.155)

FEATURES AND SPECIFICATIONS

Features and Benefits

- Mat seal friendly design features center seam and coined Electrical
- Low insertion force

Reference Information

UL File No.: E152602
 Designed In: Inches
 Used With: 19419, 19429 and 19435

Electrical

Current: 18.0A

Physical

Contact: Copper Alloy
 Plating: Tin or Gold

Mechanical

Contact Insertion Force: 1.0 lb. max.
 Durability: Tin Plating—25 cycles
 Gold Plating—100 cycles



5.84mm (.230") Pitch
MX150L™
Terminal

19417

Male

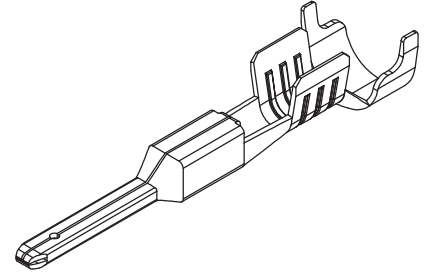

CATALOG DRAWING (FOR REFERENCE ONLY)

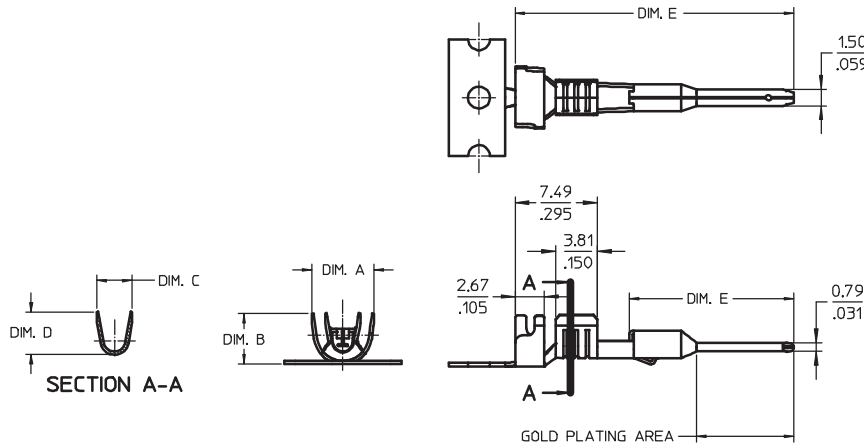

ORDERING INFORMATION

Wire Range (AWG)	Insulation Diameter mm (In)	Order No.				Pin Length	Dimension				
		Pre-Tin		Gold			A	B	C	D	E
		Strip	Loose	Strip	Loose						
18-22	2.36-2.74 (.093-.108)	19417-0024	19417-0048	19417-0026	19417-0050	Standard	4.60 (.181)	3.63 (.143)	2.50 (.098)	2.70 (.106)	25.40 (1.00)
14-16	2.87-3.53 (.113-.139)	19417-0011	19417-0047	19417-0025	19417-0049	Standard	5.66 (.223)	4.62 (.182)	3.58 (.141)	3.94 (.155)	25.40 (1.00)
18-22	2.36-2.74 (.093-.108)	19417-0028	19417-0052	19417-0030	19417-0054	Long	4.60 (.181)	3.63 (.143)	2.50 (.098)	2.70 (.106)	26.16 (1.03)
14-16	2.87-3.53 (.113-.139)	19417-0027	19417-0051	19417-0029	19417-0053	Long	5.66 (.223)	4.62 (.182)	3.58 (.141)	3.94 (.155)	26.16 (1.03)

FEATURES AND SPECIFICATIONS

Features and Benefits

- Environmentally sealed to IP67
- Integrated mat wire seal
- Integrated interface seal and terminal position assurance (TPA)
- Optional connector position assurance (CPA)
- Simple crimp-and-poke application
- Field serviceable contact removal system
- Tactile and audible mating feedback

Reference Information

UL File No.: E152602
 Designed In: Inches
 Mates With: 19419, 19429

Electrical

Dielectric Withstanding Voltage: 2200V AC min.
 Insulation Resistance: 1000 Megohms
 Voltage: 600V

Mechanical

Mating force: 75N max.
 Unmating force: 75N max.

Physical:

Housing: SPS Glass-Filled Crystalline Polymer
 Operating Temperature: -40 to +125°C



5.84mm (.230") Pitch MX150L™ Receptacle

19418 Single Row

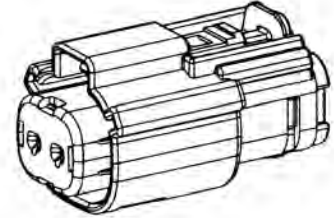

CATALOG DRAWING (FOR REFERENCE ONLY)

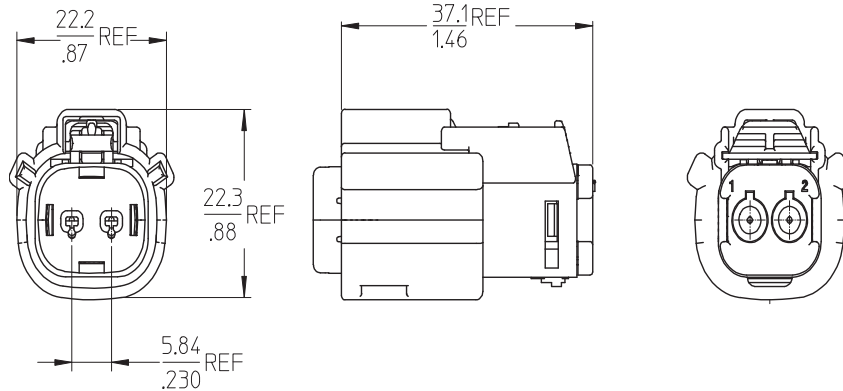

ORDERING INFORMATION

Circuits	Wire Range (AWG)	Mat Seal Color	Order No.	
			with CPA	without CPA
2	18-22	Red	19418-0008	19418-0016
	14-16	Blue	19418-0007	19418-0017

FEATURES AND SPECIFICATIONS

Features and Benefits

- Environmentally sealed to IP67
- Integrated mat wire seal and terminal position assurance (TPA)
- Simple crimp-and-poke application
- Field serviceable contact removal system
- Tactile and audible mating feedback

Reference Information

UL File No.: E152602
 Designed In: Inches
 Mates With: 19418

Electrical

Dielectric Withstanding Voltage: 2200V AC min.
 Insulation Resistance: 1000 Megohms
 Voltage: 600V

Mechanical

Mating force: 75N max.
 Unmating force: 75N max.

Physical:

Housing: SPS Glass-Filled Crystalline Polymer
 Operating Temperature: -40 to +125°C



5.84mm (.230") Pitch MX150L™ Plug

19419 Single Row

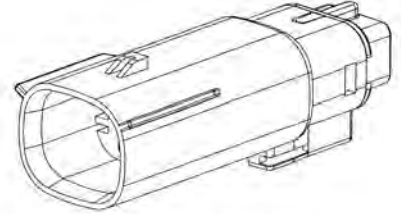

CATALOG DRAWING (FOR REFERENCE ONLY)

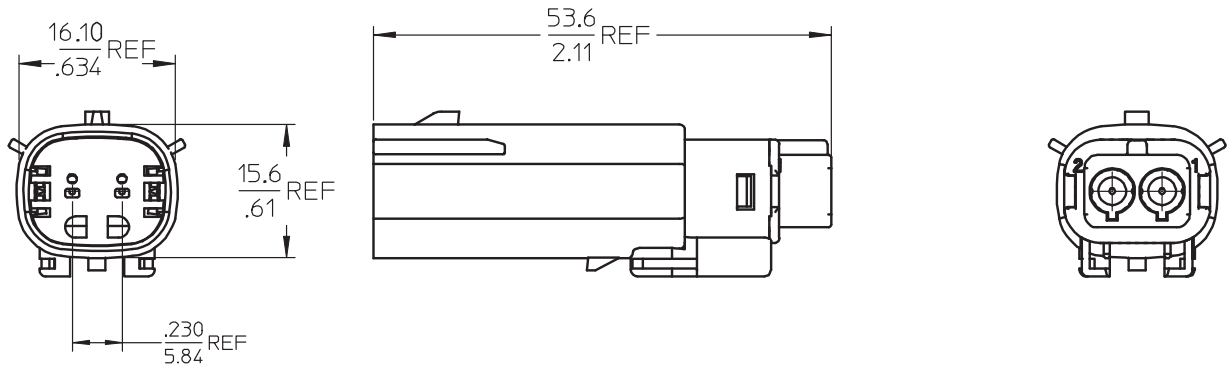

ORDERING INFORMATION

Circuits	Wire Range (AWG)	Mat Seal Color	Order No.
2	18-22	Red	19419-0008
	14-16	Blue	19419-0007

FEATURES AND SPECIFICATIONS

Features and Benefits

- Environmentally sealed to IP67
- Integrated mat wire seal and terminal position assurance (TPA)
- Optional connector position assurance (CPA)
- Simple crimp-and-poke application
- Field serviceable contact removal system
- Tactile and audible mating feedback

Reference Information

UL File No.: E152602
 Designed In: Inches
 Mates With: 19419, 19429 and 19435

Electrical

Dielectric Withstanding Voltage: 2200V AC min.
 Insulation Resistance: 1000 Megohms
 Voltage: 600V

Mechanical

Mating force: 75N max.
 Unmating force: 75N max.

Physical:

Housing: SPS Glass-Filled Crystalline Polymer
 Operating Temperature: -40 to +125°C



5.84mm (.230") Pitch
MX150L™
Receptacle

19418

Dual Row

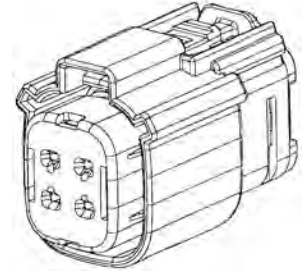

CATALOG DRAWING (FOR REFERENCE ONLY)

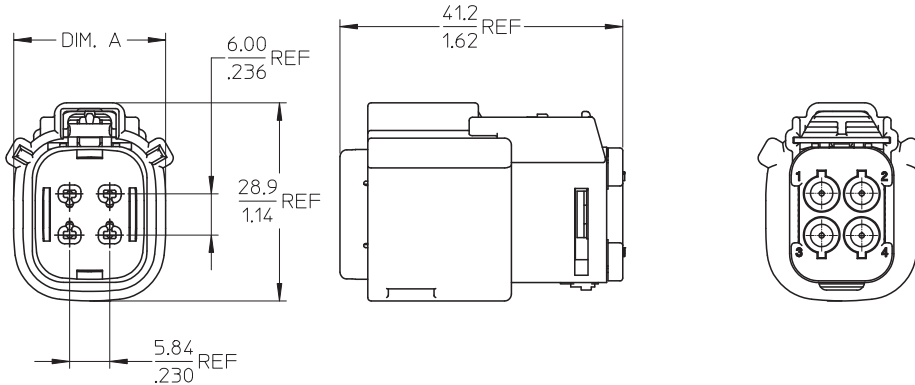

ORDERING INFORMATION

Circuits	Wire Range (AWG)	Mat Seal Color	Order No.		Dimension A
			With CPA	Without CPA	
4	18-22	Red	19418-0005	19418-0018	22.15 (.872)
	14-16	Blue	19418-0004	19418-0019	
6	18-22	Red	19418-0011	19418-0020	27.99 (1.102)
	14-16	Blue	19418-0010	19418-0021	
8	18-22	Red	19418-0001	19418-0022	33.83 (1.332)
	14-16	Blue	19418-0002	19418-0023	
10	18-22	Red	19418-0014	19418-0024	39.67 (1.562)
	14-16	Blue	19418-0013	19418-0025	
12	18-22	Red	19418-0026	19418-0038	45.51 (1.792)
	14-16	Blue	19418-0027	19418-0037	
16	18-22	Red	19418-0029	19418-0040	57.19 (2.252)
	14-16	Blue	19418-0030	19418-0039	

FEATURES AND SPECIFICATIONS

Features and Benefits

- Environmentally sealed to IP67
- Integrated mat wire seal and terminal position assurance (TPA)
- Simple crimp-and-poke application
- Field serviceable contact removal system
- Tactile and audible mating feedback

Reference Information

UL File No.: E152602
 Designed In: Inches
 Mates With: 19418

Electrical

Dielectric Withstanding Voltage: 2200V AC min.
 Insulation Resistance: 1000 Megohms
 Voltage: 600V

Mechanical

Mating force: 75N max.
 Unmating force: 75N max.

Physical:

Housing: SPS Glass-Filled Crystalline Polymer
 Operating Temperature: -40 to +125°C



**5.84mm (.230") Pitch
 MX150L™
 Plug**

19419

Dual Row

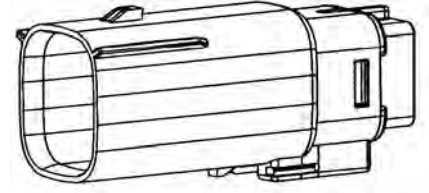

CATALOG DRAWING (FOR REFERENCE ONLY)

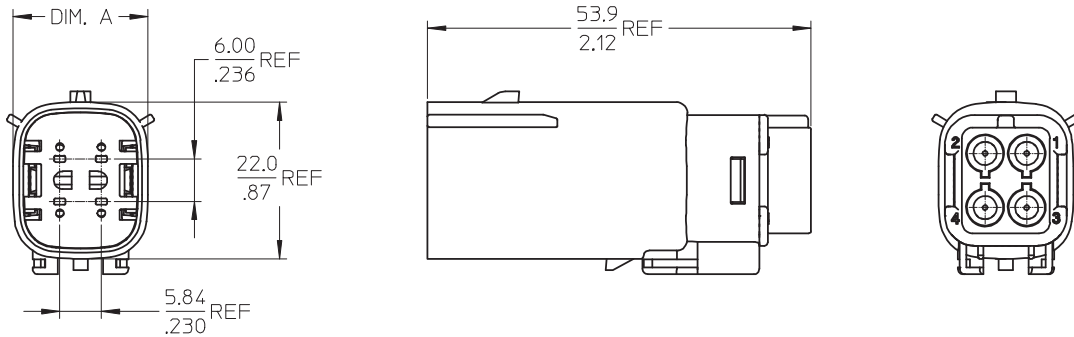

ORDERING INFORMATION

Circuits	Wire Range (AWG)	Mat Seal Color	Order No.	Dimension A
4	18-22	Red	19419-0005	16.10 (.634)
	14-16	Blue	19419-0004	
6	18-22	Red	19419-0012	24.78 (.976)
	14-16	Blue	19419-0011	
8	18-22	Red	19419-0001	30.62 (1.206)
	14-16	Blue	19419-0002	
10	18-22	Red	19419-0015	36.47 (1.436)
	14-16	Blue	19419-0014	
12	18-22	Red	19419-0017	42.31 (1.666)
	14-16	Blue	19419-0018	
16	18-22	Red	19419-0020	53.99 (2.126)
	14-16	Blue	19419-0021	

FEATURES AND SPECIFICATIONS

Features and Benefits

- Environmentally sealed to IP67 when mated
- Integrated terminal position assurance (TPA)
- Simple crimp-and-poke application
- Field serviceable contact removal system
- Tactile and audible mating feedback
- For outside or inside panel mount applications with sufficient sealing area
- Use with molded silicon panel gasket
- Blind hole boss feature eliminates leak path and reduces extra sealing process during assembly

Reference Information

UL File No.: E152602
 Designed In: Inches
 Mates With: 19418

Electrical

Dielectric Withstanding Voltage:
 2200V AC min.
 Insulation Resistance: 1000 Megohms
 Voltage: 600V

Mechanical

Mating force: 75N max.
 Unmating force: 75N max.

Physical:

Housing: SPS Glass-Filled Crystalline Polymer
 Operating Temperature: -40 to +125°C



5.84mm (.230") Pitch MX150L™ Panel Mount Plug

19429

Rear Mount Flange Single Row

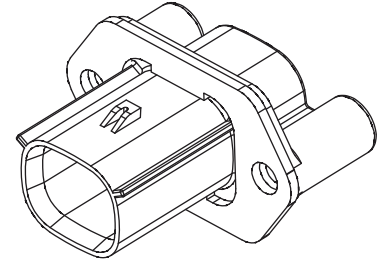

CATALOG DRAWING (FOR REFERENCE ONLY)

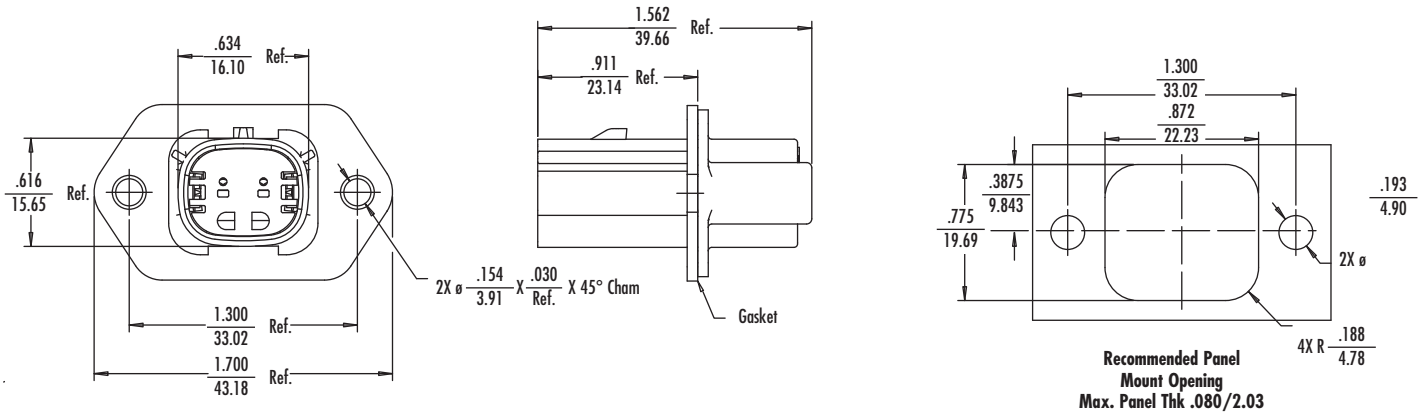

ORDERING INFORMATION

Circuits	Wire Range (AWG)	Order No.		
		With Gasket	Without Gasket	Gasket
2	14-22	19429-0033	19429-0005	19427-0025

Note: Recommended Mounting Hardware: (2) #10 x .62/18.9 long, plastic thread cutting screws
 Suggested Source: ITW Shake Proof Industrial Bosscrew or equivalent

FEATURES AND SPECIFICATIONS

Features and Benefits

- Environmentally sealed to IP67
- Integrated terminal position assurance (TPA)
- Simple crimp-and-poke application
- Field serviceable contact removal system
- Tactile and audible mating feedback
- For outside or inside panel mount applications with sufficient sealing area
- Use with molded silicon panel gasket
- Blind hole boss feature eliminates leak path and reduces extra sealing process during assembly

Reference Information

UL File No.: E152602
 Designed In: Inches
 Mates With: 19418

Electrical

Dielectric Withstanding Voltage: 2200V AC min.
 Insulation Resistance: 1000 Megohms
 Voltage: 600V

Mechanical

Mating force: 75N max.
 Unmating force: 75N max.

Physical:

Housing: SPS Glass-Filled Crystalline Polymer
 Operating Temperature: -40 to +125°C



5.84mm (.230") Pitch MX150L™ Panel Mount Plug

19429

Rear Mount Flange Dual Row

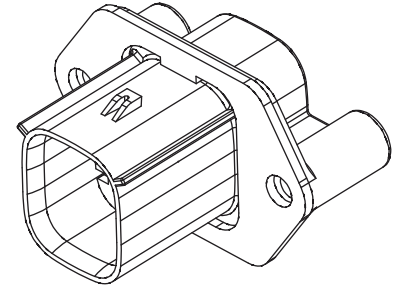

CATALOG DRAWING (FOR REFERENCE ONLY)

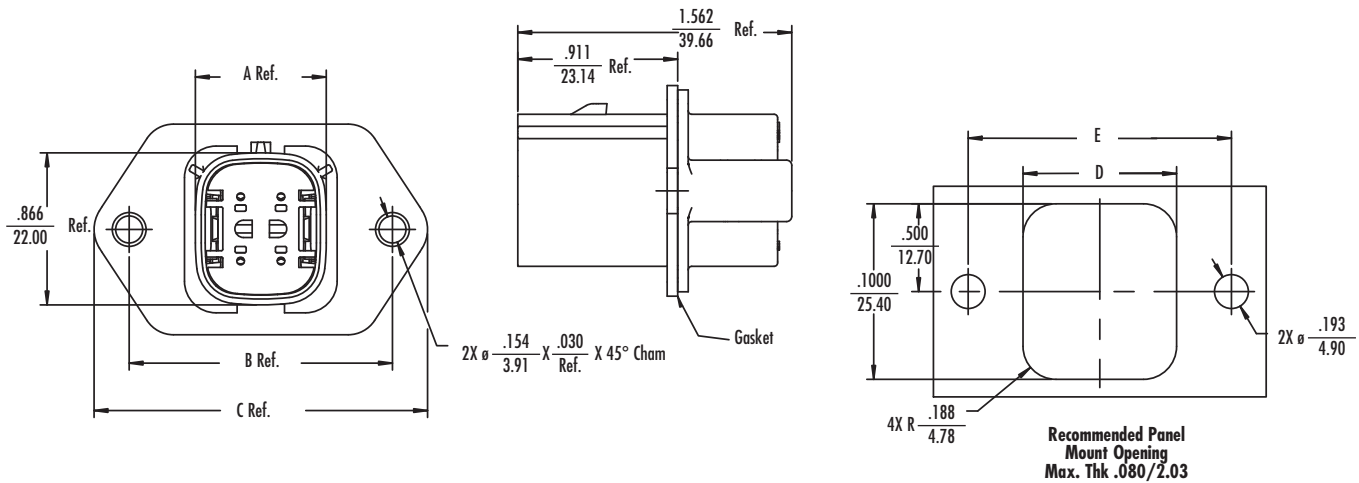

ORDERING INFORMATION

Circuits	Wire Range (AWG)	Order No.			Dimension				
		With Gasket	Without Gasket	Gasket	A	B	C	D	E
4	14-22	19429-0035	19429-0009	19427-0024	18.94 (.746)	38.10 (1.500)	48.26 (1.900)	22.23 (.875)	38.10 (1.500)
6		19429-0036	19429-0010	19427-0021	24.78 (.976)	41.92 (1.650)	52.08 (2.050)	28.07 (1.105)	41.92 (1.650)
8		19429-0037	19429-0011	19427-0022	30.62 (1.206)	48.26 (1.900)	58.42 (2.300)	33.88 (1.334)	48.26 (1.900)
10		19429-0038	19429-0014	19427-0029	36.47 (1.436)	54.61 (2.150)	64.75 (2.549)	39.75 (1.565)	54.61 (2.150)
12		19429-0039	19429-0015	19427-0030	42.31 (2.400)	60.96 (2.400)	70.97 (2.794)	45.59 (1.795)	60.96 (2.400)
16		19429-0040	19429-0016	19427-0023	53.99 (2.126)	73.67 (2.900)	83.83 (3.300)	57.28 (2.255)	73.67 (2.900)

Note: Recommended Mounting Hardware: (2) #10 x .62/18.9 long, plastic thread cutting screws
 Suggested Source: ITW Shake Proof Industrial Bosscrew or equivalent

FEATURES AND SPECIFICATIONS

Features and Benefits

- Environmentally sealed to IP67 when mated
- Integrated terminal position assurance (TPA)
- Simple crimp-and-poke application
- Field serviceable contact removal system
- Tactile and audible mating feedback
- For outside or inside panel mount applications with sufficient sealing area
- Use with molded silicon panel gasket

Reference Information

UL File No.: E152602

Designed In: Inches

Mates With: 19418

Electrical

Dielectric Withstanding Voltage: 2200V AC min.

Insulation Resistance: 1000 Megohms

Voltage: 600V

Mechanical

Mating force: 75N max.

Unmating force: 75N max.

Physical:

Housing: SPS Glass-Filled Crystalline Polymer

Operating Temperature: -40 to +125°C



5.84mm (.230") Pitch MX150L™ Panel Mount Plug

19429

Through Hole Flange Single Row

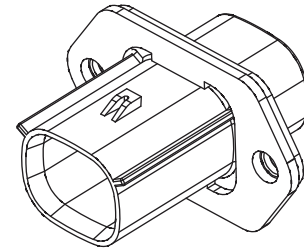

CATALOG DRAWING (FOR REFERENCE ONLY)

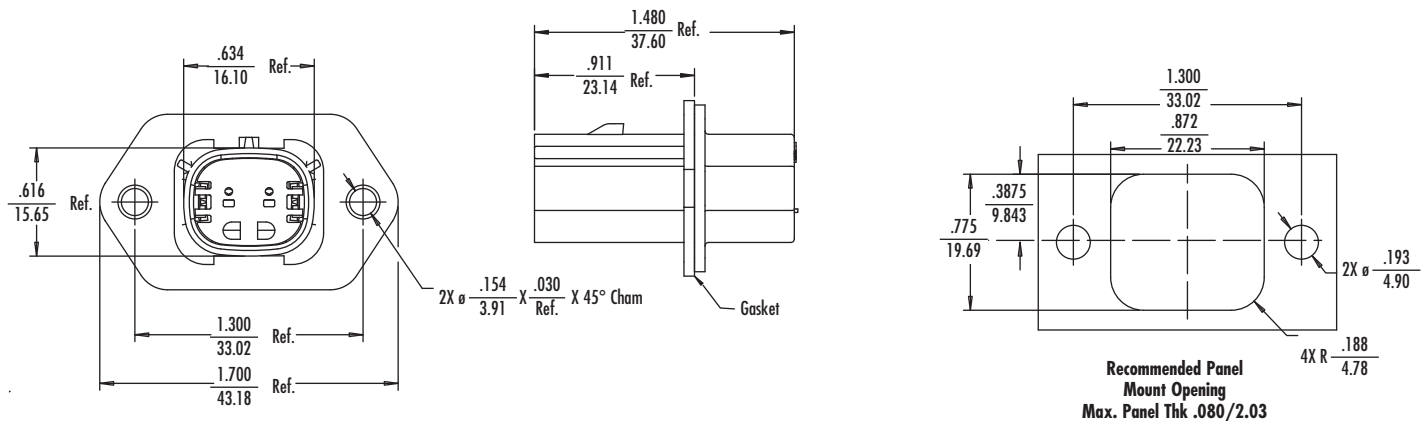

ORDERING INFORMATION

Circuits	Wire Range (AWG)	Order No.		
		With Gasket	Without Gasket	Gasket
2	14-22	19429-0041	19429-0026	19427-0025

FEATURES AND SPECIFICATIONS

Features and Benefits

- Environmentally sealed to IP67
- Integrated terminal position assurance (TPA)
- Simple crimp-and-poke application
- Field serviceable contact removal system
- Tactile and audible mating feedback
- For outside or inside panel mount applications with sufficient sealing area
- Use with molded silicon panel gasket

Reference Information

UL File No.: E152602

Designed In: Inches

Mates With: 19418

Electrical

Dielectric Withstanding Voltage: 2200V AC min.

Insulation Resistance: 1000 Megohms

Voltage: 600V

Mechanical

Mating force: 75N max.

Unmating force: 75N max.

Physical:

Housing: SPS Glass-Filled Crystalline Polymer

Operating Temperature: -40 to +125°C



5.84mm (.230") Pitch MX150L™ Panel Mount Plug

19429

Through Hole Flange Dual Row

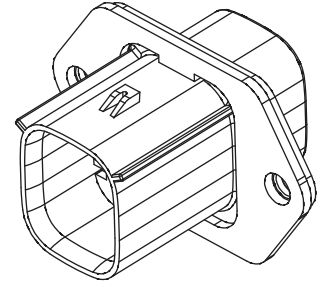

CATALOG DRAWING (FOR REFERENCE ONLY)

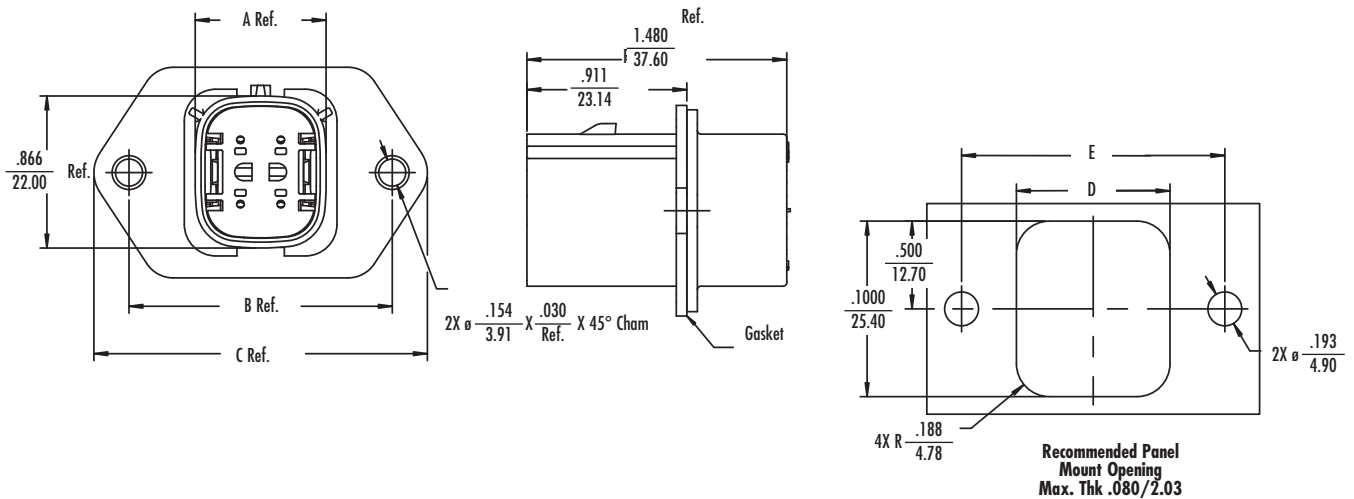

ORDERING INFORMATION

Circuits	Wire Range (AWG)	Order No.			Dimension				
		With Gasket	Without Gasket	Gasket	A	B	C	D	E
4	14-22	19429-0043	19429-0025	19427-0024	16.10 (.634)	38.10 (1.500)	48.26 (1.900)	22.23 (.875)	38.10 (1.500)
6		19429-0044	19429-0028	19427-0021	24.78 (.976)	41.92 (1.650)	52.08 (2.050)	28.07 (1.105)	41.92 (1.650)
8		19429-0045	19429-0029	19427-0022	30.62 (1.206)	48.26 (1.900)	58.42 (2.300)	33.88 (1.334)	48.26 (1.900)
10		19429-0046	19429-0030	19427-0029	36.47 (1.436)	54.61 (2.150)	64.75 (2.549)	39.75 (1.565)	54.61 (2.150)
12		19429-0047	19429-0031	19427-0030	42.31 (2.400)	60.96 (2.400)	70.97 (2.794)	45.59 (1.795)	60.96 (2.400)
16		19429-0048	19429-0032	19427-0023	53.99 (2.126)	73.67 (2.900)	83.83 (3.300)	57.28 (2.255)	73.67 (2.900)

FEATURES AND SPECIFICATIONS

Features and Benefits

- Environmentally sealed to IP67
- Mates with existing MX150L receptacles
- Supports non-closed in panels
- Field serviceable contact removal system
- Tactile and audible mating feedback
- Blind hole boss feature eliminates leak path and reduces extra sealing process during assembly

Reference Information

UL File No.: E152602
 Designed in: Inches
 Mates with: 19418

Electrical

Dielectric Withstanding Voltage:
 2200V AC min
 Insulation Resistance: 1000 Megohms min.
 Voltage: 600V

Mechanical:

Mating Force: 75N max
 Unmating Force: 75N max

Physical

Housing: Glass-Filled PBT
 Operating Temperature: -40 to +125°C



5.84mm (.230") Pitch MX150L™ Sealed Panel Mount Plug

19435

Rear Mount Flange Dual Row

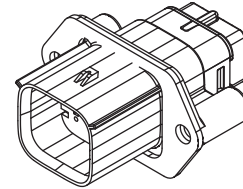

CATALOG DRAWING (FOR REFERENCE ONLY)

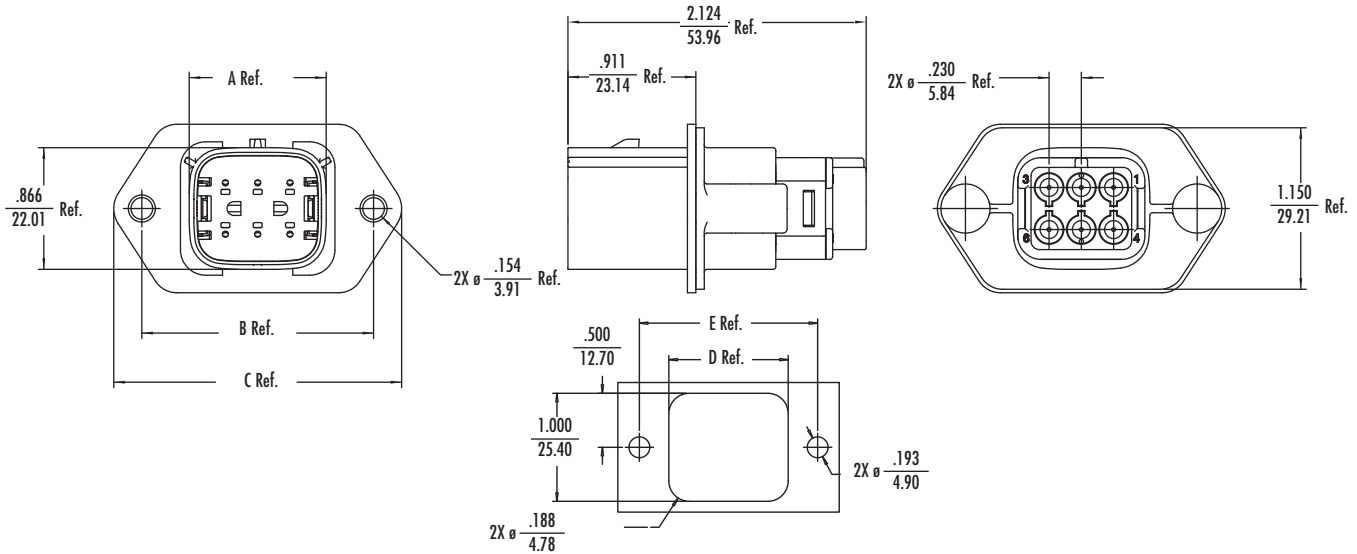

Recommended Panel Mount Opening
 Max. Thk .080/2.03

ORDERING INFORMATION

Circuits	Wire Range (AWG)	Mat Seal Color	Order No.		Dimension				
			With Gasket	Without Gasket	A	B	C	D	E
6	18-22	Red	19435-0612	19435-0614	24.78 (.976)	41.92 (1.650)	52.08 (2.050)	28.07 (1.105)	41.92 (1.650)
	14-16	Blue	19435-0611	19435-0613	24.78 (.976)	41.92 (1.650)	52.08 (2.050)	28.07 (1.105)	41.92 (1.650)
8	18-22	Red	19435-0812	19435-0814	30.62 (1.206)	48.26 (1.90)	58.42 (2.30)	33.88 (1.334)	48.26 (1.90)
	14-16	Blue	19435-0811	19435-0813	30.62 (1.206)	48.26 (1.90)	58.42 (2.30)	33.88 (1.334)	48.26 (1.90)
10	18-22	Red	19435-1012	19435-1014	36.47 (1.436)	54.61 (2.150)	64.75 (2.549)	39.75 (1.565)	54.61 (2.150)
	14-16	Blue	19435-1011	19435-1013	36.47 (1.436)	54.61 (2.150)	64.75 (2.549)	39.75 (1.565)	54.61 (2.150)
12	18-22	Red	19435-1212	19435-1214	42.31 (1.67)	60.96 (2.40)	70.97 (2.794)	45.59 (1.795)	60.96 (2.40)
	14-16	Blue	19435-1211	19435-1213	42.31 (1.67)	60.96 (2.40)	70.97 (2.794)	45.59 (1.795)	60.96 (2.40)

Note: Recommended Mounting Hardware: (2) #10 x .62/18.9 long, plastic thread cutting screws
 Suggested Source: ITW Shake Proof Industrial Bosscrew or equivalent

FEATURES AND SPECIFICATIONS

Features and Benefits

- Environmentally sealed to IP67
- Mates with existing MX150L receptacles
- Molded silicon panel gasket included
- Available in tin or gold plating
- Supports 14-22 AWG receptacle
- Tactile and audible mating feedback
- Blind hole boss feature eliminates leak path and reduces extra sealing process during assembly

Reference Information

Packaging: Tray
 UL File No.: E152602
 Designed in: Inches
 Mates with: 19418

Electrical

Dielectric Withstanding Voltage:
 2200V AC min
 Insulation Resistance: 1000 Megohms min.
 Voltage: 600V

Mechanical:

Durability: Tin Plating—25 cycles
 Gold Plating—100 cycles

Physical

Housing: Glass-Filled PBT
 Contact: Copper Alloy
 Plating: Contact Area – Tin or Gold
 Solder Tail Area – Tin
 PCB Thickness: 1.60mm (.062") max.
 Operating Temperature: -40 to +125°C



5.84mm (.230") Pitch MX150L™ PCB Header

19427

Right Angle Without PCB Flange Single Row

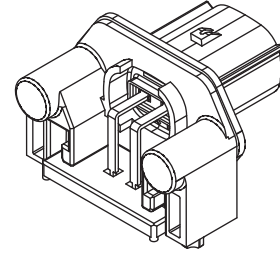

CATALOG DRAWING (FOR REFERENCE ONLY)

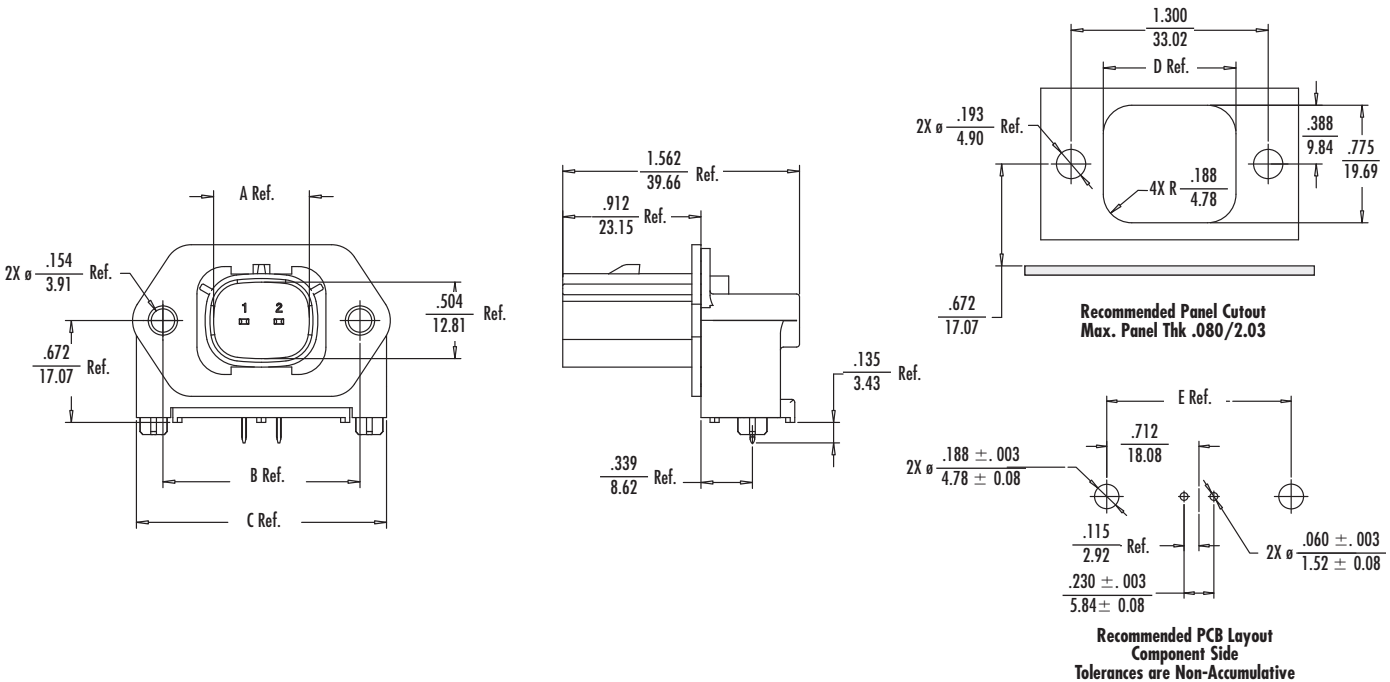

ORDERING INFORMATION

Circuits	Order No.		Dimension				
	Tin	Select Gold/Tin	A	B	C	D	E
2	19427-0040	19427-0109	16.04 (.632)	33.02 (1.300)	41.90 (1.649)	22.23 (.875)	36.14 (1.423)

Note: Recommended Mounting Hardware: (2) #10 x .62/18.9 long, plastic thread cutting screws
 Suggested Source: ITW Shake Proof Industrial Bosscrew or equivalent

FEATURES AND SPECIFICATIONS

Features and Benefits

- Environmentally sealed to IP67
- Mates with existing MX150L receptacles
- Molded silicon panel gasket included
- Available in tin or gold plating
- Supports 14-22 AWG
- Tactile and audible mating feedback
- Blind hole boss feature eliminates leak path and reduces extra sealing process during assembly

Reference Information

Packaging: Tray
 UL File No.: E152602
 Designed in: Inches
 Mates with: 19418

Electrical

Dielectric Withstanding Voltage:
 2200V AC min
 Insulation Resistance: 1000 Megohms min.
 Voltage: 600V

Mechanical:

Durability: Tin Plating—25 cycles
 Gold Plating—100 cycles

Physical

Housing: Glass-Filled PBT
 Contact: Copper Alloy
 Plating: Contact Area – Tin or Gold
 Solder Tail Area – Tin
 PCB Thickness: 1.60mm (.062") max.
 Operating Temperature: -40 to +125°C



5.84mm (.230") Pitch MX150L™ PCB Header

19427

Right Angle Without PCB Flange Dual Row

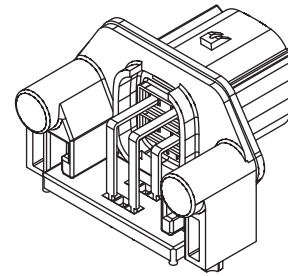

CATALOG DRAWING (FOR REFERENCE ONLY)

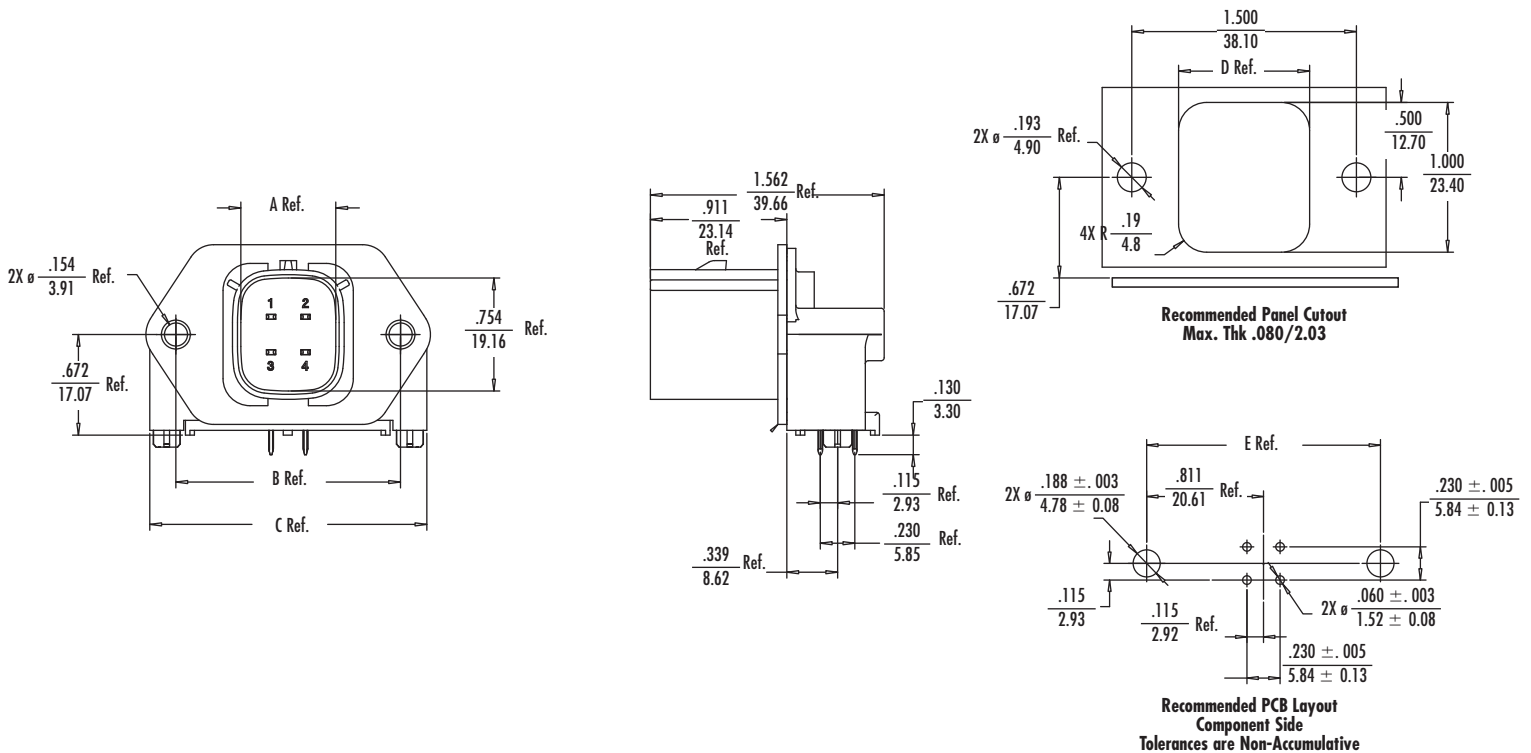

ORDERING INFORMATION

Circuits	Order No.		Dimension				
	Tin	Select Gold/Tin	A	B	C	D	E
4	19427-0032	19427-0107	16.10 (.634)	38.10 (1.50)	46.99 (1.850)	22.23 (.875)	41.24 (1.624)
6	19427-0018	19427-0106	21.94 (.864)	41.92 (1.65)	50.81 (2.0)	28.07 (1.105)	45.06 (1.774)
8	19427-0017	19427-0105	27.74 (1.092)	48.26 (1.90)	57.15 (2.250)	33.88 (1.334)	51.41 (2.024)
10	19427-0031	19427-0104	33.62 (1.324)	54.61 (2.150)	63.50 (2.50)	39.75 (1.565)	57.75 (2.274)
12	19427-0012	19427-0103	39.46 (1.554)	60.96 (2.40)	69.85 (2.750)	45.59 (1.795)	64.1 (2.524)
16	19427-0049	19427-0102	51.14 (2.014)	73.67 (2.90)	82.55 (3.250)	57.28 (2.255)	76.8 (3.024)

Note: Recommended Mounting Hardware: (2) #10 x .62/18.9 long, plastic thread cutting screws
 Suggested Source: ITW Shake Proof Industrial Bosscrew or equivalent

FEATURES AND SPECIFICATIONS

Features and Benefits

- Environmentally sealed to IP67
- Mates with existing MX150L receptacles
- Molded silicon panel gasket included
- Available in tin or gold plating
- Supports 14-22 AWG
- Tactile and audible mating feedback

Reference Information

Packaging: Tray
 UL File No.: E152602
 Designed in: Inches
 Mates with: 19418

Electrical

Dielectric Withstanding Voltage:
 2200V AC min
 Insulation Resistance: 1000 Megohms min.
 Voltage: 600V

Mechanical:

Durability: Tin Plating—25 cycles
 Gold Plating—100 cycles

Physical

Housing: Glass-Filled PBT
 Contact: Copper Alloy
 Plating: Contact Area – Tin or Gold
 Solder Tail Area – Tin
 PCB Thickness: 1.60mm (.062") max.
 Operating Temperature: -40 to +125°C



5.84mm (.230") Pitch MX150L™ PCB Header

19428

Vertical Low Profile Single Row

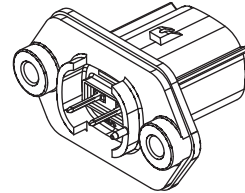

CATALOG DRAWING (FOR REFERENCE ONLY)

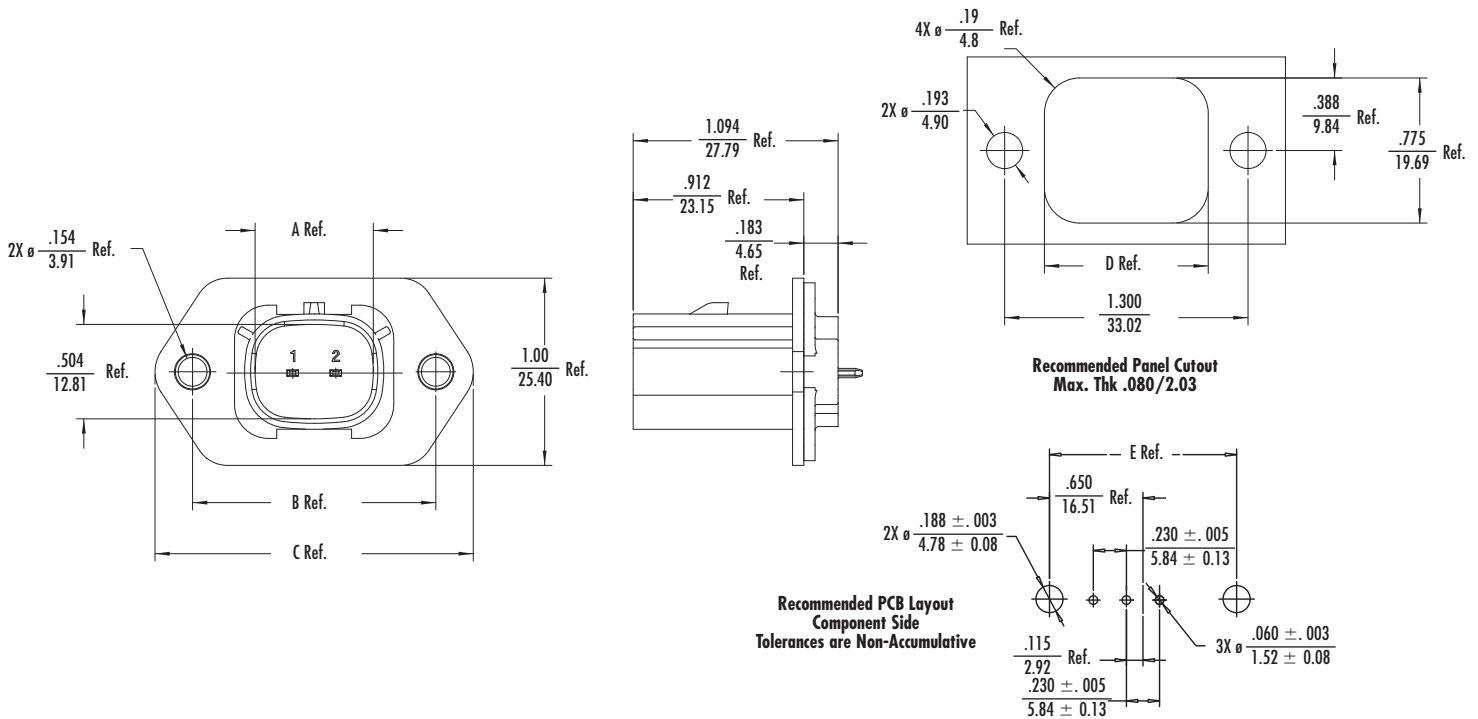

ORDERING INFORMATION

Circuits	Order No.		Dimension				
	Tin	Select Gold/Tin	A	B	C	D	E
2	19428-0009	19428-0025	16.10 (.634)	33.01 (1.300)	43.18 (1.70)	22.23 (.875)	33.02 (1.30)

FEATURES AND SPECIFICATIONS

Features and Benefits

- Environmentally sealed to IP67
- Mates with existing MX150L receptacles
- Molded silicon panel gasket included
- Available in tin or gold plating
- Supports 14-22 AWG receptacle
- Tactile and audible mating feedback

Reference Information

Packaging: Tray
 UL File No.: E152602
 Designed in: Inches
 Mates with: 19418

Electrical

Dielectric Withstanding Voltage:
 2200V AC min
 Insulation Resistance: 1000 Megohms min.
 Voltage: 600V

Mechanical:

Durability: Tin Plating—25 cycles
 Gold Plating—100 cycles

Physical

Housing: Glass-Filled PBT
 Contact: Copper Alloy
 Plating: Contact Area – Tin or Gold
 Solder Tail Area – Tin
 PCB Thickness: 1.60mm (.062") max.
 Operating Temperature: -40 to +125°C



5.84mm (.230") Pitch MX150L™ PCB Header

19428 Vertical Low Profile Dual Row

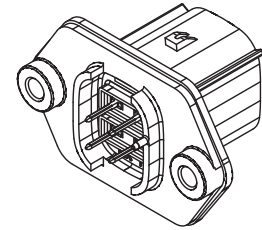

CATALOG DRAWING (FOR REFERENCE ONLY)

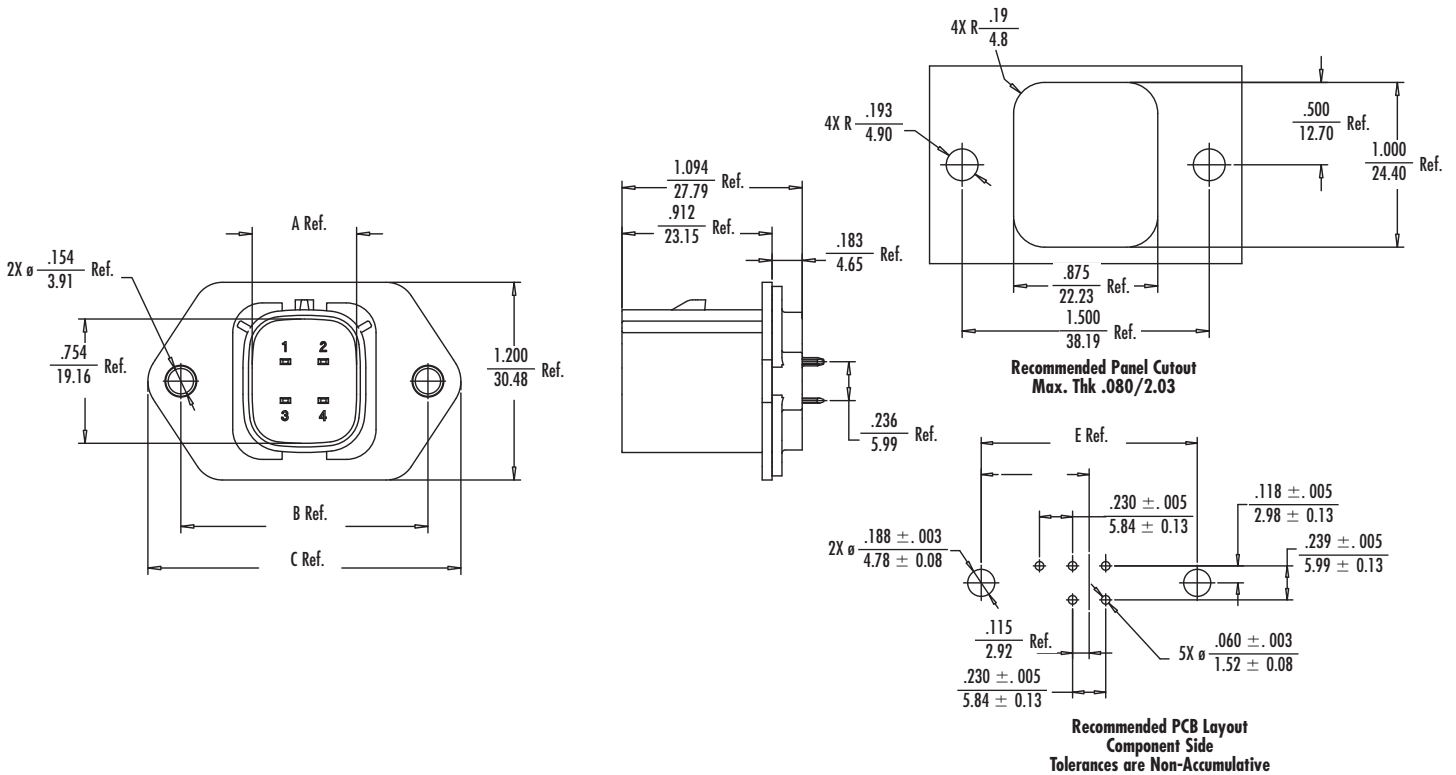

ORDERING INFORMATION

Circuits	Order No.		Dimension			
	Tin	Select Gold/Tin	A	B	C	E
4	19428-0011	19428-0027	16.10 (.634)	38.10 (1.50)	48.26 (1.90)	38.10 (1.50)
6	19428-0012	19428-0028	21.94 (.864)	41.92 (1.65)	52.08 (2.050)	41.91 (1.65)
8	19428-0013	19428-0029	27.74 (1.092)	48.26 (1.90)	58.42 (2.30)	48.26 (1.90)
10	19428-0014	19428-0030	33.62 (1.324)	54.61 (2.150)	64.75 (2.54)	54.61 (2.15)
12	19428-0015	19428-0031	39.46 (1.554)	60.96 (2.40)	71.12 (2.80)	60.96 (2.40)
16	19428-0016	19428-0032	53.99 (2.126)	73.67 (2.90)	83.83 (3.30)	73.66 (2.90)

FEATURES AND SPECIFICATIONS

Features and Benefits

- Environmentally sealed to IP67
- Mates with existing MX150L receptacles
- Molded silicon panel gasket included
- Available in tin or gold plating
- Supports 14-22 AWG receptacle
- Tactile and audible mating feedback
- Blind hole boss feature eliminates leak path and reduces extra sealing process during assembly

Reference Information

Packaging: Tray
 UL File No.: E152602
 Designed in: Inches
 Mates with: 19418

Electrical

Dielectric Withstanding Voltage:
 2200V AC min
 Insulation Resistance: 1000 Megohms min.
 Voltage: 600V

Mechanical:

Durability: Tin Plating—25 cycles
 Gold Plating—100 cycles

Physical

Housing: Glass-Filled PBT
 Contact: Copper Alloy
 Plating: Contact Area – Tin or Gold
 Solder Tail Area – Tin
 PCB Thickness: 1.60mm (.062") max.
 Operating Temperature: -40 to +125°C



5.84mm (.230") Pitch MX150L™ PCB Header

19428

Vertical Standard Profile Single Row

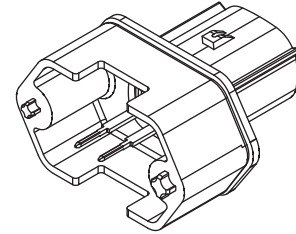

CATALOG DRAWING (FOR REFERENCE ONLY)

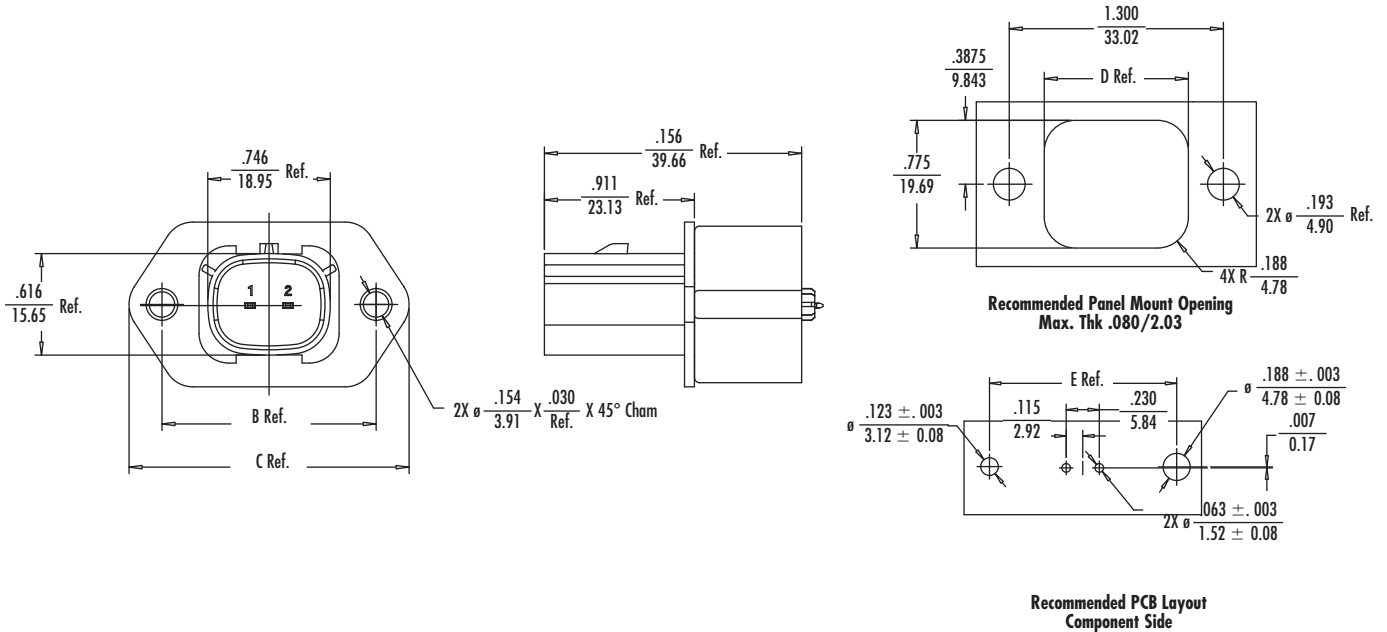

ORDERING INFORMATION

Circuits	Order No.		Dimension			
	Tin	Select Gold/Tin	B	C	D	E
2	19428-0007	19428-0017	33.01 (1.300)	43.18 (1.70)	22.23 (.875)	33.02 (1.30)

Note: Recommended Mounting Hardware: (2) #10 x .62/18.9 long, plastic thread cutting screws
 Suggested Source: ITW Shake Proof Industrial Bosscrew or equivalent

FEATURES AND SPECIFICATIONS

Features and Benefits

- Environmentally sealed to IP67
- Mates with existing MX150L receptacles
- Molded silicon panel gasket included
- Available in tin or gold plating
- Supports 14-22 AWG receptacle
- Tactile and audible mating feedback
- Blind hole boss feature eliminates leak path and reduces extra sealing process during assembly

Reference Information

Packaging: Tray
 UL File No.: E152602
 Designed in: Inches
 Mates with: 19418

Electrical

Contact Resistance: milliohms max.
 Dielectric Withstanding Voltage: 2200V AC min
 Insulation Resistance: 1000 Megohms min.
 Voltage: 600V

Mechanical:

Durability: Tin Plating—25 cycles
 Gold Plating—100 cycles

Physical

Housing: Glass-Filled PBT
 Contact: Copper Alloy
 Plating: Contact Area – Tin or Gold
 Solder Tail Area – Tin
 PCB Thickness: 1.60mm (.062") max.
 Operating Temperature: -40 to +125°C



5.84mm (.230") Pitch MX150L™ PCB Header

19428

Vertical Standard Profile Dual Row

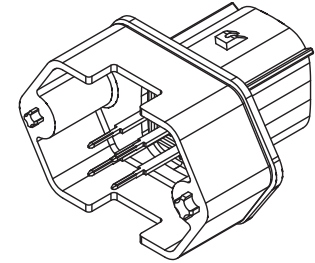

CATALOG DRAWING (FOR REFERENCE ONLY)

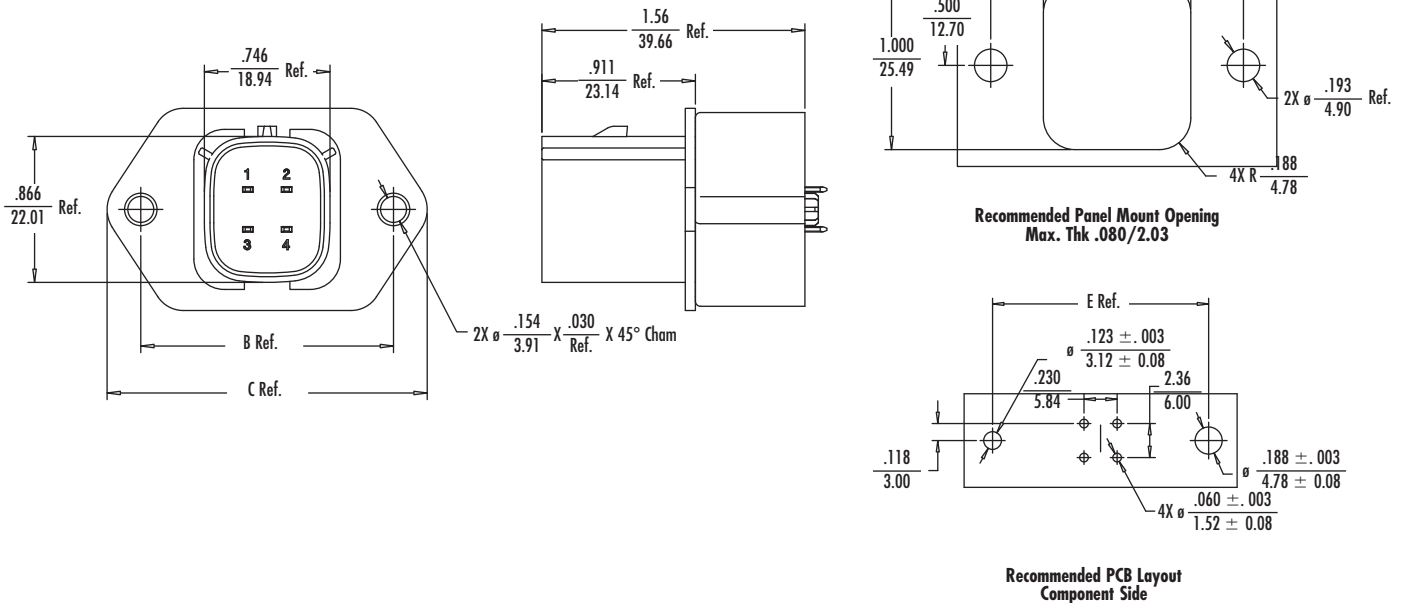

ORDERING INFORMATION

Circuits	Order No.		Dimension			
	Tin	Select Gold/Tin	B	C	D	E
4	19428-0006	19428-0019	38.10 (1.50)	48.26 (1.90)	22.23 (.875)	38.10 (1.50)
6	19428-0004	19428-0020	41.92 (1.65)	52.08 (2.050)	28.07 (1.105)	41.91 (1.65)
8	19428-0003	19428-0021	48.26 (1.90)	58.42 (2.30)	33.88 (1.334)	48.26 (1.90)
10	19428-0005	19428-0022	54.61 (2.150)	64.75 (2.54)	39.75 (1.565)	54.61 (2.15)
12	19428-0001	19428-0023	60.96 (2.40)	71.12 (2.80)	45.59 (1.795)	60.96 (2.40)
16	19428-0002	19428-0024	73.67 (2.90)	83.83 (3.30)	57.28 (2.255)	73.66 (2.90)

Note: Recommended Mounting Hardware: (2) #10 x .62/18.9 long, plastic thread cutting screws
 Suggested Source: ITW Shake Proof Industrial Bosscrew or equivalent

FEATURES AND SPECIFICATIONS

With the application of optional circuit plugs, the MX150L system supports the ability to implement sealed blank cavities in both plug and receptacle housings. The circuit plugs occupy and fully seal the unused cavity and can be extracted and replaced with a standard male blade or female receptacle terminal. This feature provides the ability to plan for possible future circuit additions while maintaining the sealing integrity of the mated pair.

Reference Information

Use With: 19418, 19419 and 19435



Physical

Material: SPS Glass-Filled Crystalline Polymer
Operating Temperature: -40 to +125°C

5.84mm (.230") Pitch MX150L™ Unused Cavity Circuit Plugs

19417

14 to 22 AWG



CATALOG DRAWING (FOR REFERENCE ONLY)

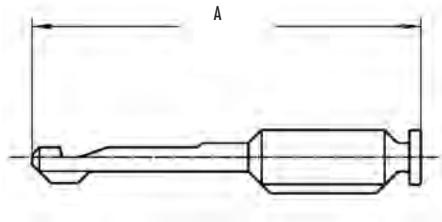

ORDERING INFORMATION

Housing Series	Order No.	Dimension A
19418	19417-0263*	33.9 (1.3)
	19417-0119	34.3 (1.4)
19419		
19435		

* For use with 19418 receptacles when mating to PCB headers.

FEATURES AND SPECIFICATIONS

Features and Benefits

- Mat seal friendly design features center seam and coined edges
- High current
- Low insertion force

Reference Information

UL File No.: E152602
 Designed in: Inches
 Use with: 19432

Electrical

Current: 10-12 AWG—30.0A
 8 AWG—40.0A

Physical

Contact: Copper Alloy
 Plating: Tin

Mechanical

Contact Insertion Force: 1lb
 Durability: 25 cycles



7.62mm (.300") Pitch
MX150L™
Terminal

19434

8, 10, 12 AWG
Female

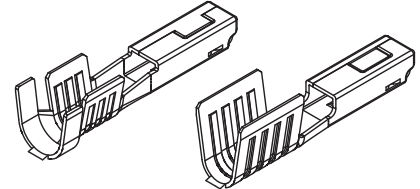

10-12 AWG

8 AWG

CATALOG DRAWING (FOR REFERENCE ONLY)

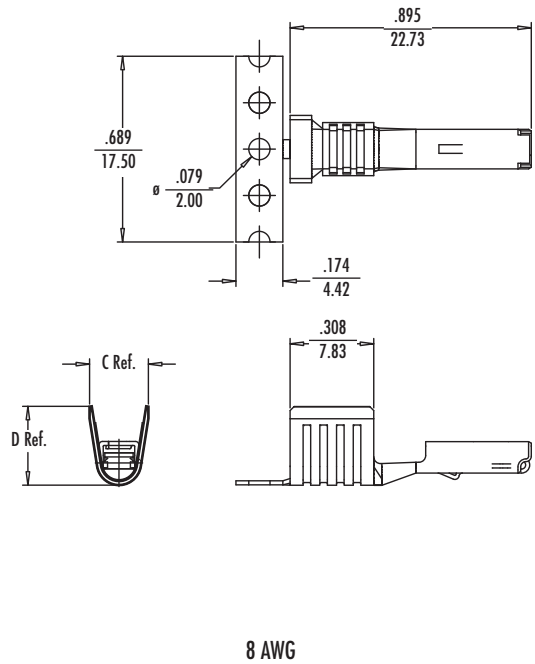
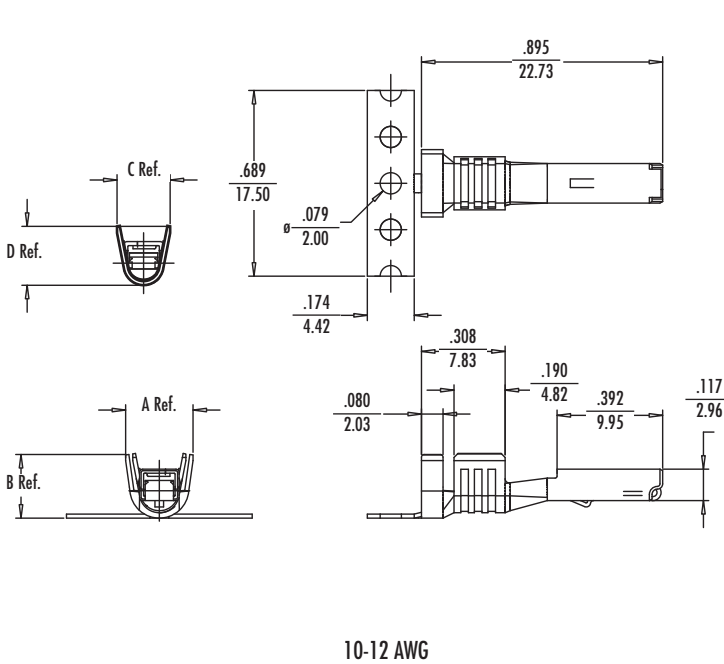

ORDERING INFORMATION

Wire Range (AWG)	Insulation Diameter mm (In)	Order No.		Dimension			
		Loose	Strip	A	B	C	D
10-12	3.94-4.45 (.155-.175)	19434-0003	19434-0001	6.35 (.250)	6.00 (.236)	5.00 (.197)	5.60 (.220)
8	6.02 (.237)	19434-0004	19434-0002	n/a	n/a	6.10 (.240)	7.0 (.276)

FEATURES AND SPECIFICATIONS

Features and Benefits

- Mat seal friendly design features center seam and coined edges
- High current
- Low insertion force
- Mates With: 19433 and 19436

Reference Information

UL File No.: E152602
 Designed in: Inches
 Use with: 19433 and 19436

Electrical

Current: 10-12 AWG—30.0A
 8 AWG—40.0A

Physical

Contact: Copper Alloy
 Plating: Tin

Mechanical

Contact Insertion Force: 1lb
 Durability: 25 cycles



7.62mm (.300") Pitch MX150L™ Terminal

19431

8, 10, 12 AWG Male

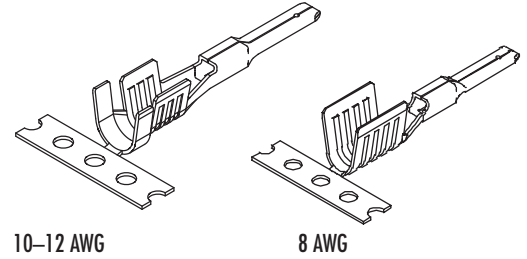

10-12 AWG

8 AWG

CATALOG DRAWING (FOR REFERENCE ONLY)

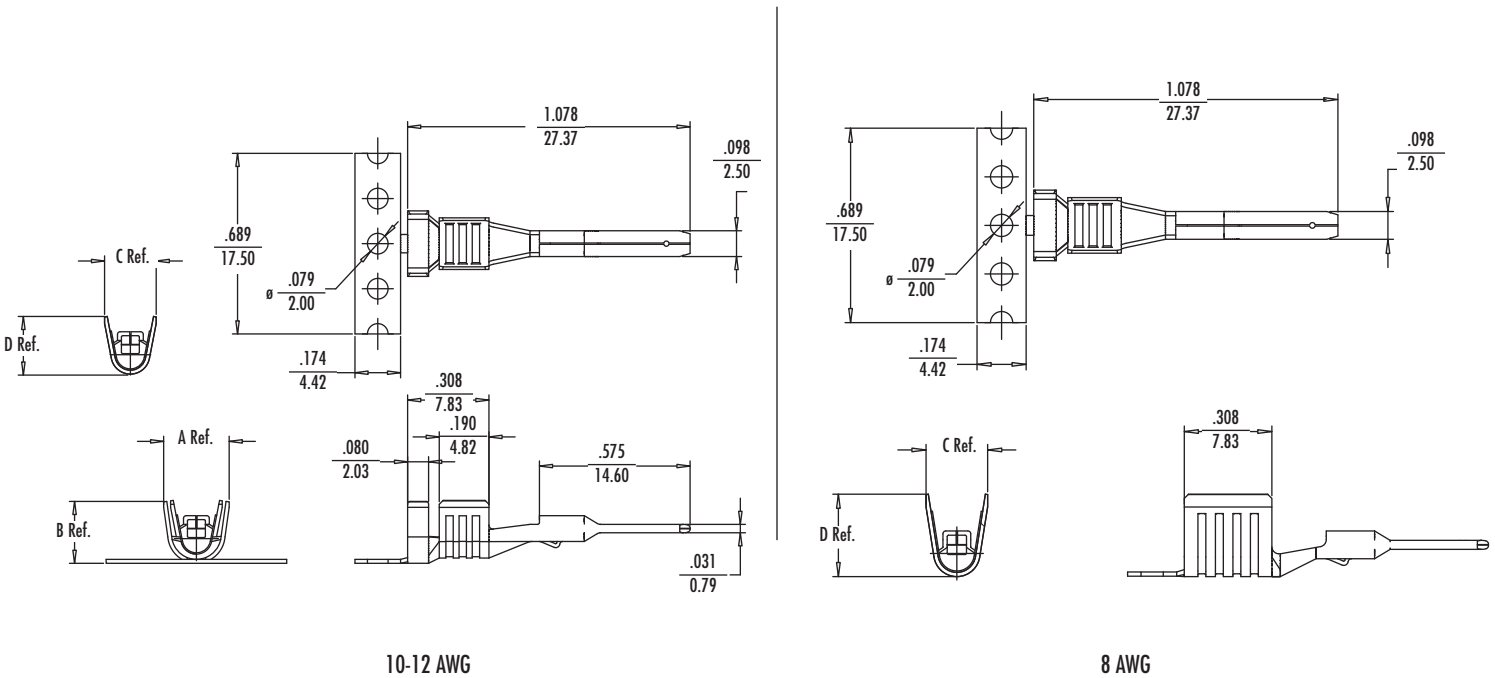

10-12 AWG

8 AWG

ORDERING INFORMATION

Wire Range (AWG)	Insulation Diameter mm (In)	Order No.		Dimension			
		Loose	Strip	A	B	C	D
10-12	3.94-4.45 (.155-.175)	19431-0016	19431-0001	6.35 (.250)	6.00 (.236)	5.00 (.197)	5.60 (.220)
8	6.02 (.237)	19431-0017	19431-0015	n/a	n/a	6.10 (.240)	7.0 (.276)

FEATURES AND SPECIFICATIONS

Features and Benefits

- Environmentally sealed to IP67
- Integrated mat wire seal and terminal position assurance
- High current
- Field serviceable contact removal system
- Simple crimp-and-poke application
- Tactile and audible mating feedback
- CPA connector position assurance included

Reference Information

UL File No.: E152602
 Designed in: Inches
 Mates with: 19433 and 19436
 Use with: 19434

Electrical

Dielectric Withstanding Voltage:
 2200V AC min
 Insulation Resistance: 1000 Megohms min.
 Voltage: 600V

Mechanical:

Mating Force: 75N max
 Unmating Force: 75N max

Physical

Housing: Glass-Filled PBT
 Operating Temperature: -40 to +125°C



7.62mm (.300") Pitch MX150L™ Receptacle

19432

8,10,12 AWG Single Row

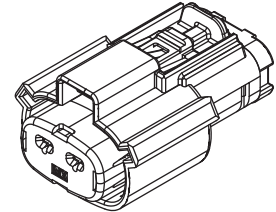

CATALOG DRAWING (FOR REFERENCE ONLY)

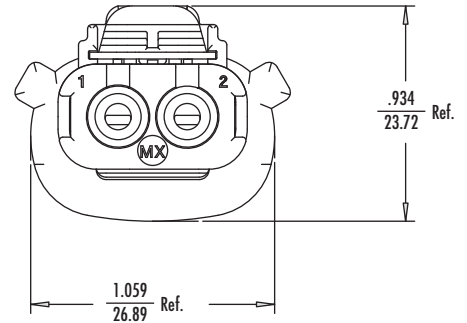
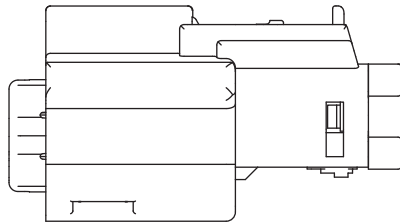
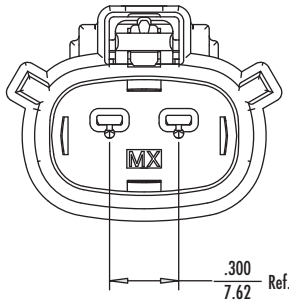

ORDERING INFORMATION

Circuits	Wire Range (AWG)	Mat Seal Color	Order No.
2	10-12	Yellow	19432-0013
	8	Red	19432-0014

FEATURES AND SPECIFICATIONS

Features and Benefits

- Environmentally sealed to IP67
- Integrated mat wire seal and terminal position assurance
- High current
- Field serviceable contact removal system
- Simple crimp-and-poke application
- Tactile and audible mating feedback
- Mates With: 19433 and 19436

Reference Information

UL File No.: E152602
 Designed in: Inches
 Mates with: 19432
 Use with: 19431

Electrical

Dielectric Withstanding Voltage:
 2200V AC min
 Insulation Resistance: 1000 Megohms min.
 Voltage: 600V

Mechanical:

Mating Force: 75N max
 Unmating Force: 75N max

Physical

Housing: Glass-Filled PBT
 Operating Temperature: -40 to +125°C



7.62mm (.300") Pitch MX150L™ Plug

19433

8,10,12 AWG Single Row

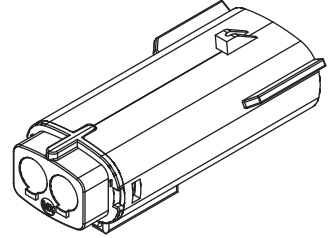

CATALOG DRAWING (FOR REFERENCE ONLY)

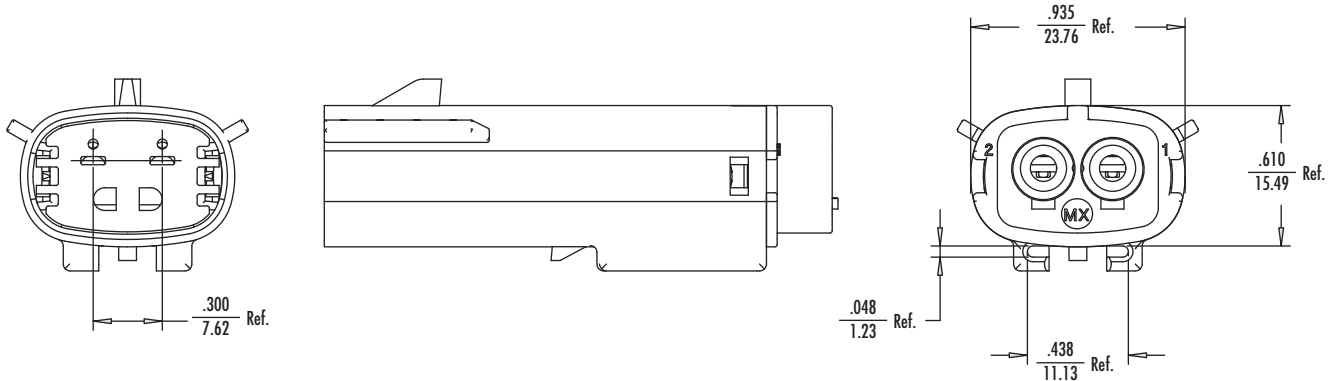

ORDERING INFORMATION

Circuits	Wire Range (AWG)	Mat Seal Color	Order No.
2	10-12	Yellow	19433-0013
	8	Red	19433-0014

FEATURES AND SPECIFICATIONS

Features and Benefits

- Environmentally sealed to IP67
- Integrated mat wire seal and terminal position assurance
- High current
- Field serviceable contact removal system
- Simple crimp-and-poke application
- Tactile and audible mating feedback

Reference Information

UL File No.: E152602
 Designed in: Inches
 Mates with: 19433 and 19436
 Use with: 19434

Electrical

Dielectric Withstanding Voltage:
 2200V AC min
 Insulation Resistance: 1000 Megohms min.
 Voltage: 600V

Mechanical:

Mating Force: 75N max
 Unmating Force: 75N max

Physical

Housing: Glass-Filled PBT
 Operating Temperature: -40 to +125°C



7.62mm (.300") Pitch MX150L™ Receptacle

19432

8,10,12 AWG Dual Row

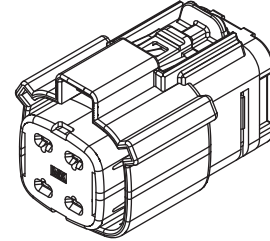

CATALOG DRAWING (FOR REFERENCE ONLY)

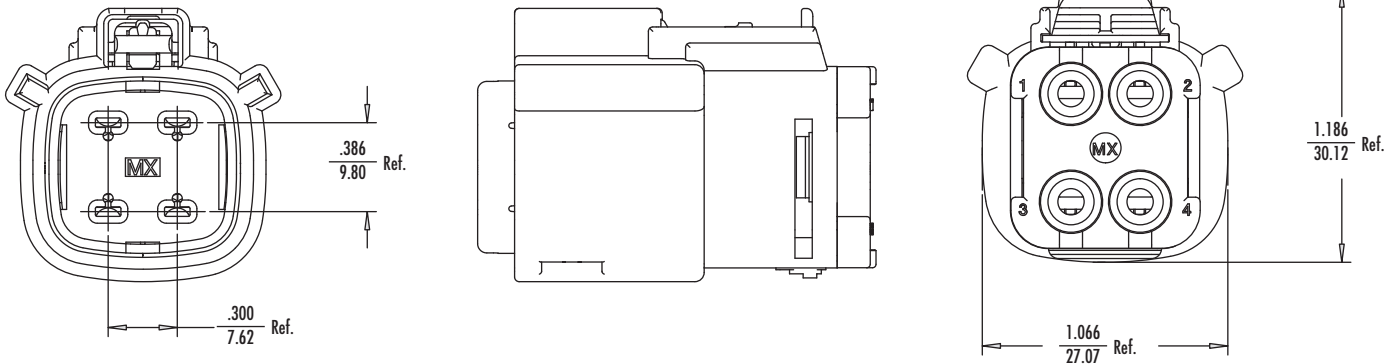

ORDERING INFORMATION

Circuits	Wire Range (AWG)	Mat Seal Color	Order No.
4	10-12	Yellow	19432-0001
	8	Red	19432-0002

FEATURES AND SPECIFICATIONS

Features and Benefits

- Environmentally sealed to IP67
- Integrated mat wire seal and terminal position assurance
- High current
- Field serviceable contact removal system
- Simple crimp-and-poke application
- Tactile and audible mating feedback
- Mates With: 19432

Reference Information

UL File No.: E152602
 Designed in: Inches
 Mates with: 19432
 Use with: 19431

Electrical

Dielectric Withstanding Voltage:
 2200V AC min
 Insulation Resistance: 1000 Megohms min.
 Voltage: 600V

Mechanical:

Mating Force: 75N max
 Unmating Force: 75N max

Physical

Housing: Glass-Filled PBT
 Operating Temperature: -40 to +125°C



7.62mm (.300") Pitch MX150L™ Plug

19433

8,10,12 AWG Dual Row

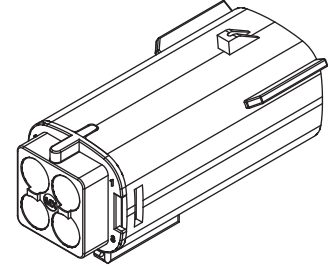

CATALOG DRAWING (FOR REFERENCE ONLY)

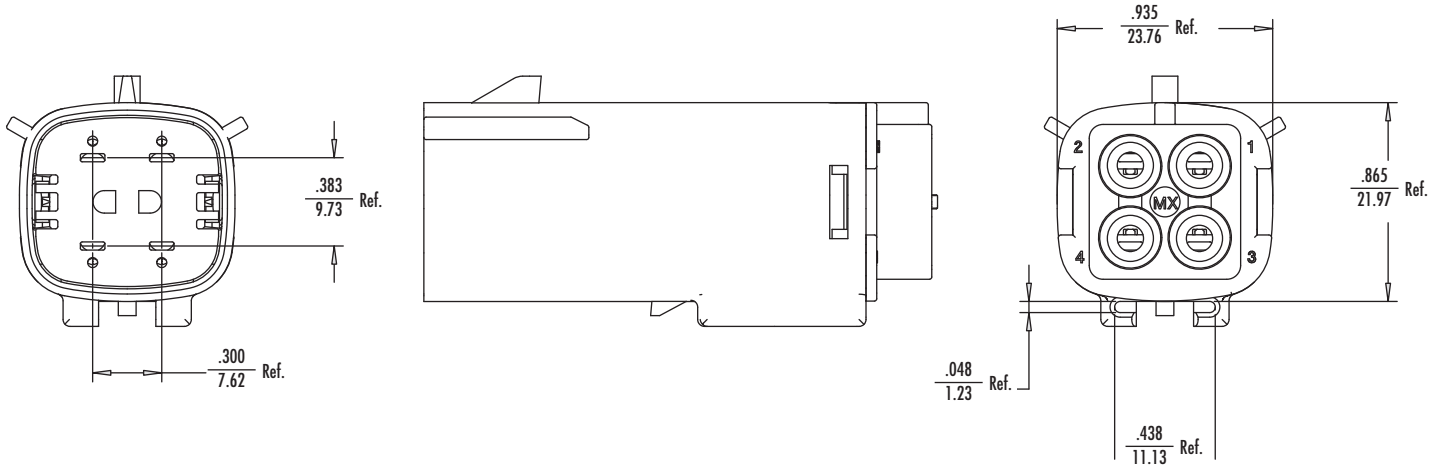

ORDERING INFORMATION

Circuits	Wire Range (AWG)	Mat Seal Color	Order No.
4	10-12	Yellow	19433-0001
	8	Red	19433-0002

FEATURES AND SPECIFICATIONS

Features and Benefits

- Environmentally sealed to IP67
- Mates with existing MX150L receptacles
- Supports non-closed in panels
- Field serviceable contact removal system
- Tactile and audible mating feedback
- Blind hole boss feature eliminates leak path and reduces extra sealing process during assembly
- Mates With: 19432

Reference Information

UL File No.: E152602
 Designed in: Inches
 Mates with: 19432
 Use with: 19431

Electrical

Dielectric Withstanding Voltage:
 2200V AC min
 Insulation Resistance: 1000 Megohms min.
 Voltage: 600V

Mechanical:

Mating Force: 75N max
 Unmating Force: 75N max

Physical

Housing: Glass-Filled PBT
 Operating Temperature: -40 to +125°C



7.62mm (.300") Pitch
 MX150L™

Sealed Panel Mount Plug

19436

Rear Mount Flange
 Single Row

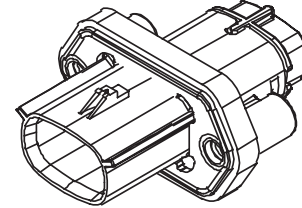

CATALOG DRAWING (FOR REFERENCE ONLY)

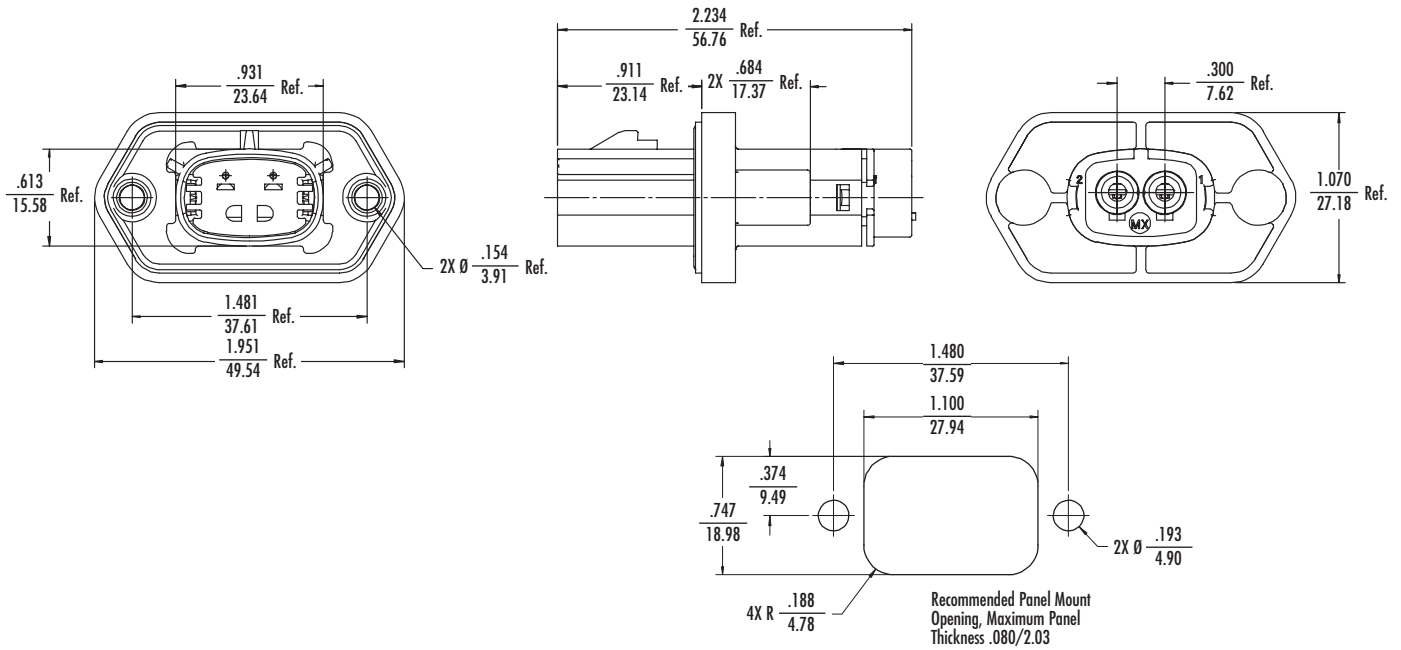

ORDERING INFORMATION

Circuits	Wire Range (AWG)	Order No.		
		With Gasket	Without Gasket	Gasket
2	10-12	19436-0213	19436-0211	19436-0001
	8	19436-0214	19436-0212	

Note: Recommended Mounting Hardware: (2) #10 x .62/18.9 long, plastic thread cutting screws
 Suggested Source: ITW Shake Proof Industrial Bosscrew or equivalent

FEATURES AND SPECIFICATIONS

Features and Benefits

- Environmentally sealed to IP67
- Mates with existing MX150L receptacles
- Supports non-closed in panels
- Field serviceable contact removal system
- Tactile and audible mating feedback
- Blind hole boss feature eliminates leak path and reduces extra sealing process during assembly

Reference Information

UL File No.: E152602
 Designed in: Inches
 Mates with: 19432
 Use with: 19431

Electrical

Dielectric Withstanding Voltage:
 2200V AC min
 Insulation Resistance: 1000 Megohms min.
 Voltage: 600V

Mechanical:

Mating Force: 75N max
 Unmating Force: 75N max

Physical

Housing: Glass-Filled PBT
 Operating Temperature: -40 to +125°C



7.62mm (.300") Pitch MX150L™ Sealed Panel Mount Plug

19436

Rear Mount Flange Dual Row

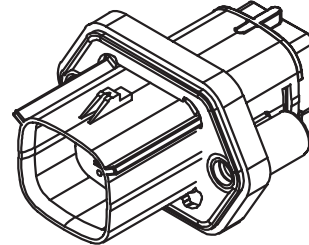

CATALOG DRAWING (FOR REFERENCE ONLY)

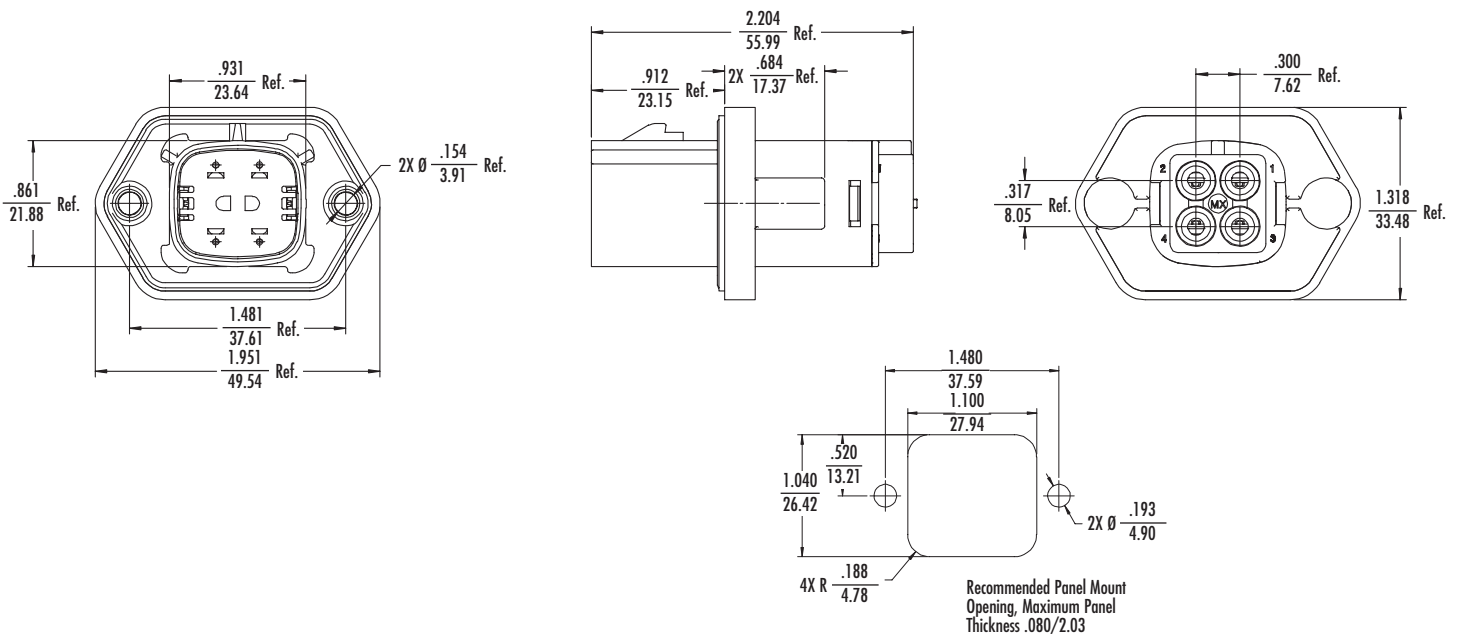

ORDERING INFORMATION

Circuits	Wire Range (AWG)	Order No.		
		Without Gasket	With Gasket	Gasket
4	10-12	19436-0413	19436-0411	19436-0002
	8	19436-0414	19436-0412	

Note: Recommended Mounting Hardware: (2) #10 x .62/18.9 long, plastic thread cutting screws
 Suggested Source: ITW Shake Proof Industrial Bosscrew or equivalent

FEATURES AND SPECIFICATIONS

With the application of optional circuit plugs, the MX150L system supports the ability to implement sealed blank cavities in both plug and receptacle housings. The circuit plugs occupy and fully seal the unused cavity and can be extracted and replaced with a standard male blade or female receptacle terminal. This feature provides the ability to plan for possible future circuit additions while maintaining the sealing integrity of the mated pair.

Reference Information

Use With: 19433 and 19432

Physical

Material: Glass-Filled PBT

Operating Temperature: -40 to +125°C



7.62mm (.300") Pitch MX150L™ Unused Cavity Circuit Plug

19431

8,10,12 AWG

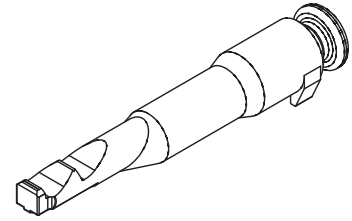

CATALOG DRAWING (FOR REFERENCE ONLY)

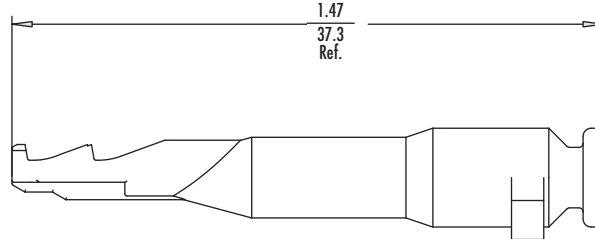

ORDERING INFORMATION

Housing Series	Order No.
19433	19431-0013
19432	19431-0013

FEATURES AND SPECIFICATIONS



Semi-Automatic Bench Top Crimp Press Tooling

FineAdjust™ Applicator

Features and Benefits

- FineAdjust allows users to achieve target with little effort by adjusting on increments of 0.15mm (.0006") for conductor crimp height and .063mm (.0025") for insulation height
- Independent adjustment rings allow users to quickly adjust the conductor or insulation crimp height without affecting each other
- Quick tooling removal with the push of a button for fast and easy tooling change
- Track adjustment for bellmouth and cut-off tab is adjusted while the applicator is in the press for fast and easy setup
- Compatible with the Molex TM-2000™ Universal Press and most industry standard presses, however, it does not fit into Molex TM-40™/TM-42™ press
- Directly adapts to most automatic wire processing machines
- Quick set-up time; plus the crimp height, track and feed adjustments can be preset in applicator
- Applicator designed to industry standard mounting and shut height 135.80mm (5.346")
- FineAdjust available for most Molex brand terminals

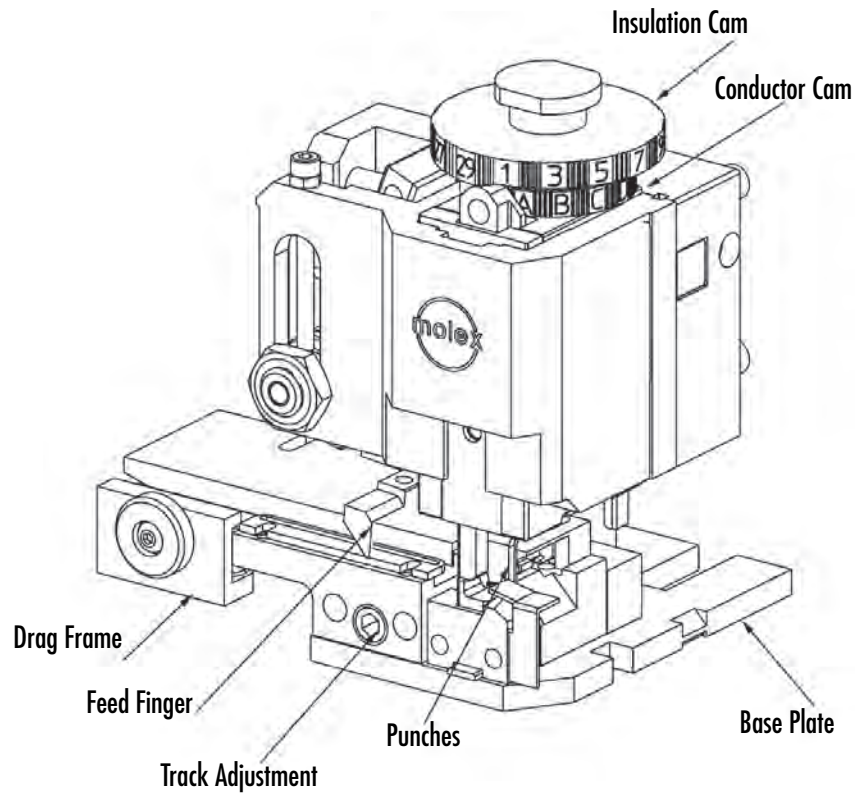

FEATURES AND SPECIFICATIONS

Features and Benefits

- Ergonomically designed soft handles
- Precisely designed crimping profiles with simple contact positioning
- Easy handling due to outstanding force ratio
- This tool type reduces work related injuries

Manual Hand Crimp Tool

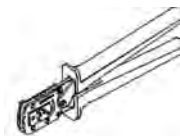

ORDERING INFORMATION

Terminal Series No.	Terminal Type	Tool Type	Order No.	Wire Gauge AWG (mm)
19417/19420	MX150L™ Male and Female	FineAdjust Applicator	63865-6000	14-16 (2.00-1.30)
19417/19420	MX150L Male and Female	Perishable Tool Kit	63865-6070	14-16 (2.00-1.30)
19417/19420	MX150L Male and Female	T2 Terminator Die	63855-6000	14-16 (2.00-1.30)
19417	MX150L Male	FineAdjust Applicator	63865-6100	18-22 (0.80-0.35)
19417	MX150L Male	Perishable Tool Kit	63865-6170	18-22 (0.80-0.35)
19417	MX150L Male	T2 Terminator Die	63855-6100	18-22 (0.80-0.35)
19420	MX150L Female	FineAdjust Applicator	63865-6200	18-22 (0.80-0.35)
19420	MX150L Female	Perishable Tool Kit	63865-6270	18-22 (0.80-0.35)
19420	MX150L Female	T2 Terminator Die	63855-6200	18-22 (0.80-0.35)
19417/19420	MX150L Male and Female	OEM PremiumGrade™ Hand Tool	63811-4400	14-22 (2.00-0.35)
19417/19420	MX150L Male and Female	ServiceGrade™ Hand Tool	64016-0035	14-22 (2.00-0.35)
19434/19417/19420/19431	MX150L Male and Female	Terminal Extraction Tool	63813-1500	8-22 (.237-0.35)
19431/19434	MX150L Male and Female	FineAdjust Applicator	63832-5000	10-12 (3.94-4.45)
19431/19434	MX150L Male and Female	Perishable Tool Kit	63832-5070	10-12 (3.94-4.45)
19431/19434	MX150L Male and Female	OEM PremiumGrade Hand Tool	63811-5300	10-12 (3.94-4.45)
19431/19434	MX150L Male and Female	FineAdjust Applicator	63832-5100	8 (.237)
19431/19434	MX150L Male and Female	Perishable Tool Kit	63832-5170	8 (.237)
19431/19434	MX150L Male and Female	OEM PremiumGrade Hand Tool	63811-5400	8 (.237)
19431/19434	MX150L Male and Female	ServiceGrade Hand Tool	64016-0079	10-12 (3.94-4.45)
19431/19434	MX150L Male and Female	ServiceGrade Hand Tool	64016-0089	8 (.237)

- 1) Return TPA to pre-lock position
- Carefully insert a standard screw driver into slot on top of TPA.
 - Carefully pry TPA forward and listen for audible click.
 - TPA is now in pre-lock position.

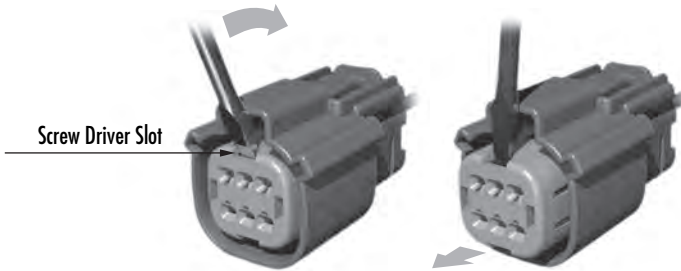

- 2) Release terminal from connector assembly
- Insert and drive forward extractor tool to release terminal.
 - Pull terminal from rear of connector.

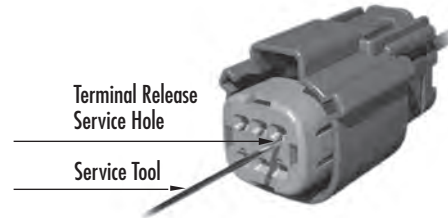

SEALED BLADE ASSEMBLY - SERVICEABILITY

- 1) Return TPA to pre-lock position
- Use standard needle nose pliers to return TPA to pre-lock position.
 - Insert needle nose pliers into service hole and carefully pull TPA.
 - Listen for loud audible click.
 - TPA is now in pre-lock position.

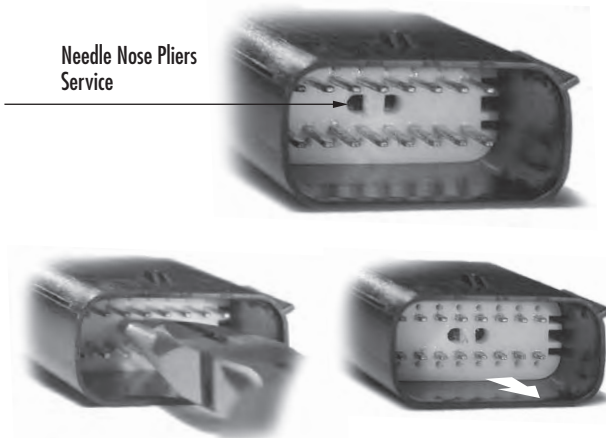

- 2) Release terminal from connector assembly
- Insert and drive forward extractor tool to release terminal.
 - Pull terminal from rear of connector.

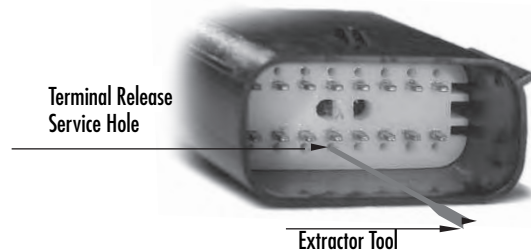

TERMINAL INSTALLATION

Assure housing TPA is in pre-lock position. Align polarization feature on terminal with keyway in seal cap. Insert terminal and push until seated. Push receptacle TPA back to locked position. Plug TPA will return to locked position when mated with receptacle housing.

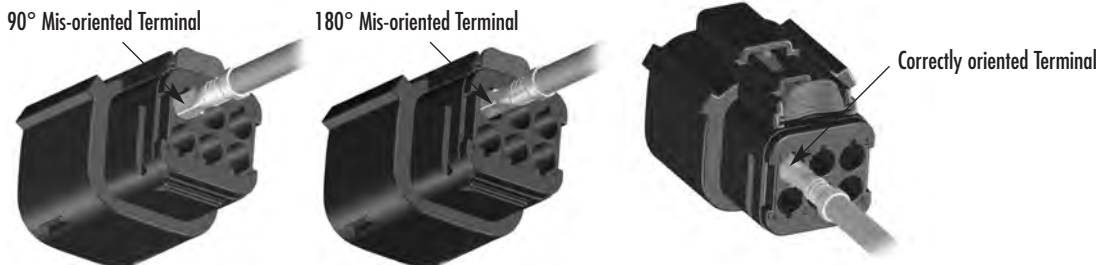

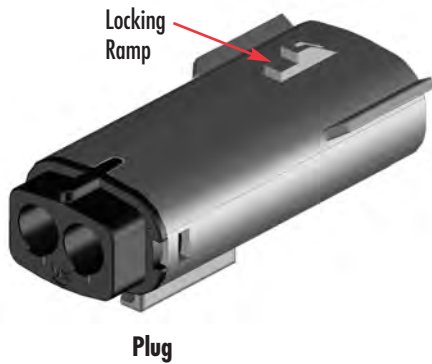

To Mate:

1. Firmly push connectors together until you feel them snap together, you should hear a click. This audible and tactile confirmation ensures the connectors are properly and fully mated.

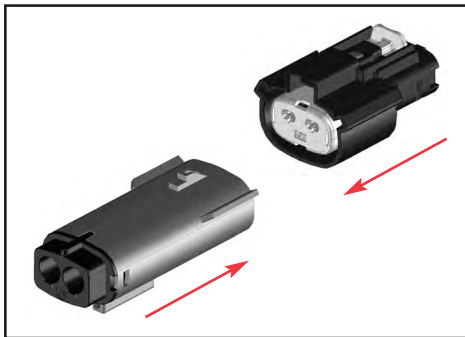

2. Press CPA towards plug to engage the secondary lock.



To Unmate:

1. Pull back CPA



2. Fully depress locking latch

Locking latch must be fully depressed to release the locking ramp on the plug and allow the connectors to be separated!

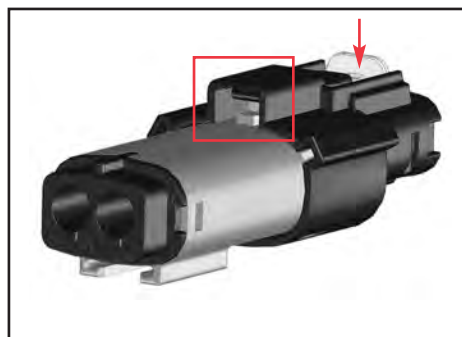

3. Pull connectors apart

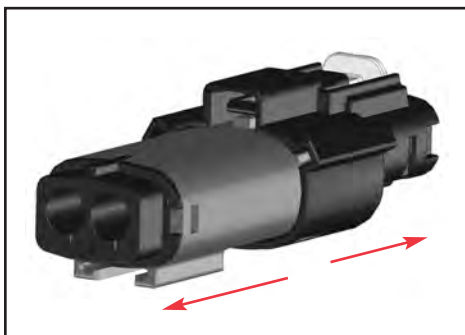

Locking latch shown down, cannot unmate connectors



Locking latch shown fully depressed, latch releases locking ramp



Americas Headquarters

Lisle, Illinois 60532 U.S.A.
1-800-78MOLEX
amerinfo@molex.com

Asia Pacific North Headquarters

Yamato, Kanagawa, Japan
81-46-265-2325
apninfo@molex.com

Asia Pacific South Headquarters

Jurong, Singapore
65-6268-6868
apsinfo@molex.com

European Headquarters

Munich, Germany
49-89-413092-0
eurinfo@molex.com

Corporate Headquarters

2222 Wellington Ct.
Lisle, IL 60532 U.S.A.
630-969-4550
Fax: 630-969-1352

Visit our Web site at <http://www.molex.com>