

8 kW PSU for AI – server SMPS

REF_8KW_HFHD_PSU - enabled by SiC, GaN and Si

Over the past years, server and data center applications have continuously increased their power demand, which has driven the evolution of the power supply units (PSU) into higher powers (800 W to up to 5.5 kW) and higher output voltages (12 V_{DC} to 50 V_{DC} bus). Moreover, the requirements for efficiency of the PSU has risen to levels of more than 98 %, but with still higher power densities (e.g., 100 W/in³) while maintaining strict hold-up time requirements.

Artificial intelligence (AI) applications are fast-developing and require even higher power than other traditional data center applications. With inputs from data center operators and power supply manufacturers who support them, Infineon has developed an 8 kW PSU reference board by combining Infineon's three semiconductor technologies of power switches, each of them in their right place for achieving benchmark efficiency and power density. The new Infineon 8 kW PSU reference board following the ORv3 guidelines to support today's and future requirements of AI racks with levels of up to 300 kW and more.

Highlight products

- CoolSiC™ MOSFET 650 V
- CoolGaN™ Transistors 650 V
- 600 V CoolMOS™ 8 SJ MOSFET
- CoolSiC™ Schottky diode 650 V
- OptiMOS™ 5 power MOSFET 80 V
- ISOFACE™ digital isolator
- EiceDRIVER™ 1EDB, 1EDN, 2EDB
- CoolSET™ flyback controller with integrated 800 V CoolMOS™
- OPTIREG™ switchers

Key features

- Benchmark efficiency of 98% (reduced optimized for reduced cooling effort)
- High power density 100 W/in³ (twice as much than the ORv3 specification)
- Highest switching frequency in the full bridge LLC thanks to GaN transistors
- Full digital control for both interleaved bridgeless totem-pole PFC + full-bridge LLC
- Proprietary and integrated magnetics design
- Available as reference board

Functional blocks of 8 kW PSU solution

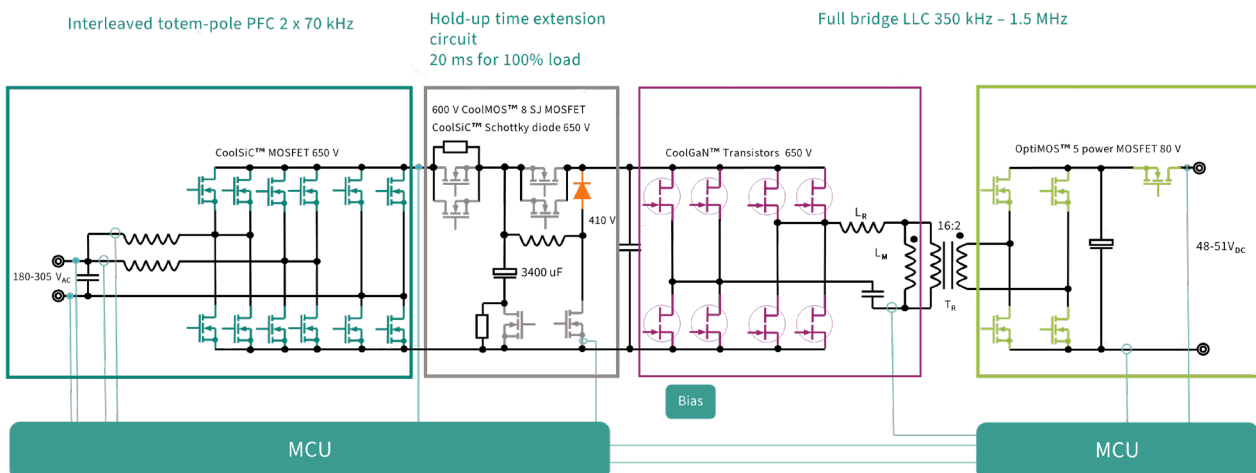

SOLUTION BRIEF

The REF_8KW_HFHD_PSU is Infineon's power supply unit (PSU) reference board, targeting today's and future Artificial Intelligence (AI) rack infrastructure power demands.

The 8 kW PSU reference board for AI requirements comprises a front-end interleaved bridgeless totem-pole and a back-end isolated full-bridge LLC in a smaller form-factor than the OCP ORv3 5.5 kW PSU.

The input of the PSU is single-phase high-line grid ($180 V_{AC}$ to $305 V_{AC}$) and the output is nominal $50 V_{DC}$ with up to 160 A.

This design takes advantage of the best features of each of the distinct power semiconductor technologies of Infineon, i.e. SiC, GaN and Si in hybrid switch approach - using them, where they provide the highest benefit. The bridgeless totem-pole uses SiC due to the lower temperature coefficient of its $R_{DS(on)}$. The high-frequency LLC uses GaN due to their lower capacitances. Meanwhile for the rectification (both in the PFC and the DCDC), where switching loss is not a contribution, Si devices are used due to their lowest $R_{DS(on)}$.

Finally, to comply with strict hold-up time requirements while not sacrificing power density, the 8kW PSU includes an auxiliary boost that helps fully utilizing the intermediate energy storage.

Key benefits

- Complete power supply unit (PSU) including single-phase PFC + DCDC
- Maximized PSU system performance by using Infineon's three switch technology SiC, GaN and Si in hybrid switch approach
- Following OCPv3 form factor for server
- Reduced bulk capacitor thanks in auxiliary hold-up extension circuit (for higher reliability and condensed system size).
- Highest efficiency and power density

PSU board blocks

- 1 Hold-up time extension circuit
- 2 AC/DC PFC
- 3 EMI filter
- 4 DC/DC FB-LLC

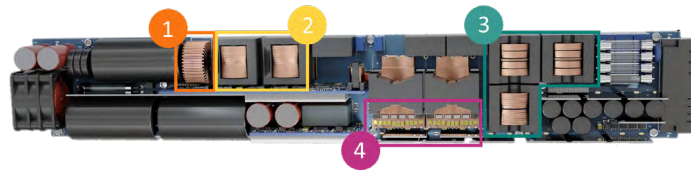

Input
 $180 V_{AC} - 305 V_{AC}$

←

→

Output
 $48 V_{DC} - 51 V_{DC}$

PSU key requirements	Value
Input voltage range	$180 V_{AC} \sim 305 V_{AC}$
Output voltage range	$48 V_{DC} - 51 V_{DC}$
Output power max	8 kW
Hold-up time	20 ms



www.infineon.com

Published by
 Infineon Technologies AG
 Am Campeon 1-15, 85579 Neubiberg
 Germany

© 2024 Infineon Technologies AG
 All rights reserved.

Public

Date: 05/2024

Please note!

This Document is for information purposes only and any information given herein shall in no event be regarded as a warranty, guarantee or description of any functionality, conditions and/or quality of our products or any suitability for a particular purpose. With regard to the technical specifications of our products, we kindly ask you to refer to the relevant product data sheets provided by us. Our customers and their technical departments are required to evaluate the suitability of our products for the intended application.

We reserve the right to change this document and/or the information given herein at any time.

Additional information

For further information on technologies, our products, the application of our products, delivery terms and conditions and/or prices, please contact your nearest Infineon Technologies office (www.infineon.com).

Warnings

Due to technical requirements, our products may contain dangerous substances. For information on the types in question, please contact your nearest Infineon Technologies office.

Except as otherwise explicitly approved by us in a written document signed by authorized representatives of Infineon Technologies, our products may not be used in any life-endangering applications, including but not limited to medical, nuclear, military, life-critical or any other applications where a failure of the product or any consequences of the use thereof can result in personal injury.