

iMX RT1052/62 OEM Board Feature Highlights

- NXP i.MX RT1052/62 ARM Cortex-M7, up to 600 MHz
- 4 MByte OctalSPI Flash, EcoXiP from Adesto Tech.
- 32 MByte SDRAM, 16-bit databus, optional
- 10/100 Mbps Ethernet PHY, optional
- Parallel RGB graphical output
- Multiple connectivity interfaces
- Low-power consumption - very power efficient
- FreeRTOS BSP
- **Multiple Wi-Fi solutions available**
- 68 x 30 mm SODIMM200 form factor
- Long term availability



Introduction

The **iMX RT1052/62 OEM Board** provides a quick and easy solution for implementing a high-performance ARM Cortex-M7 based design. The i.MX RT1052/62 is the highest performing Cortex-M7 with Real Time Operation and an applications processor level of functionality, delivering 3015 CoreMark/1284 DMIPS @ 600 MHz. It has very low dynamic power consumption, enabled by integrated DC-DC converter and efficient power gating - as low as 110uA/MHz.

The i.MX RT1052/62 supports **2D graphical acceleration** and has a parallel RGB display interface, up to 1366 x 768px resolution. It also has high security enabled by AES-128, HAB and On-the-fly QSPI Flash Decryption.

Rapid and easy development with support from major microcontroller tool chains. The BSP contains a FreeRTOS port. Typical applications are graphical interface solutions for home, building and industrial control, communication solutions and connected real-time systems.

Specification

Processor	Core / MCU	ARM Cortex-M7 / NXP i.MX RT1052/62
	Frequency	600 MHz / 528MHz (commercial/industrial temp range)
Memory	On-chip SRAM	i.MX RT1052: 512 KByte FlexRAM, can be used as Tightly Coupled Memory (TCM) i.MX RT1062: 1 MByte (512 KByte FlexRAM, like above, and 512 KByte OCRAM)
	SDRAM	32 MByte, 16-bit databus, optional
	FLASH	4 MByte OctalSPI EcoXiP, supports high performance eXecute-In-Place
Graphics output	Parallel RGB	Up to 24-bit, up to 1366 x 768 pixels
	Graphics Engine	PXP - PiXel Processing pipeline for imagine resize, rotation, overlay and color space conversion.
Graphics input	CMOS sensor interface (camera)	Parallel, up to 24 bit
I/O (all functions are not available at the same time)	Ethernet	10/100 Mbps Ethernet interface, optional i.MX RT1062 has an additional Ethernet interface (requires external Ethernet-PHY)
	USB	2x FS USB2.0 OTG
	UART, SPI, I2C, Audio	8x UART, 4x SPI, 4x I2C, 3x SAI, S/PDIF
	CAN	2x CAN bus 2.0B
	GPIO, FlexIO	Large number of GPIOs and keypad pins available, 2x FlexIO blocks
	Memory card	1x SD3.0
	ADC and Analogue	16ch 12-bit resolution, 4x comparators
Other	Boot parameters	E2PROM storing board information including Ethernet MAC address
	Watchdog	On-board watchdog functionality
	RTC	On-chip iMX RT1052/62
	Power Management	On-chip iMX RT1052/62 power management
	Accelerators	Encryption engine co-processor, True random number generator

Power	Supply voltage	+3.3V
	Power consumption	See datasheet for details. Typically much less than 1 Watt.
Environment	Operating Temperature	0 - 70° or -40 - 85° Celsius
	Operating Humidity	5 - 90% relative humidity, non-condensing
Mechanical	Dimensions (W x H x D)	67.8 x 30 x 5 mm
Connectors		SODIMM200 edge connector with 0.6mm pitch, 1.8V keying

Note that all interfaces may not be available simultaneously due to I/O multiplexing limitations.

Block Diagram

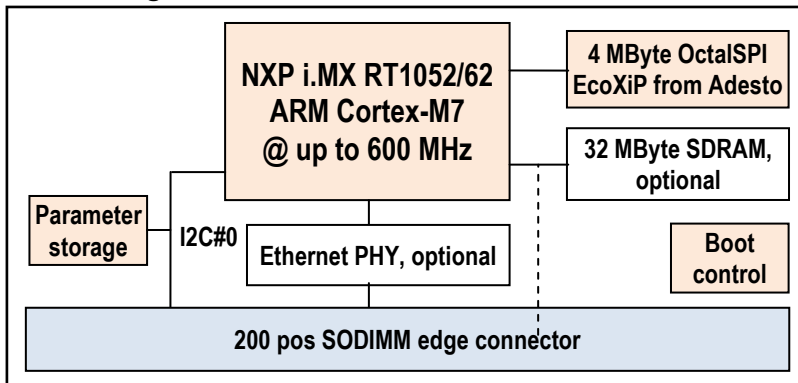

Ordering Information

Part No. ^[1]	CPU	Core Frequency	SDRAM	Ethernet	Operating Temperature
EAC00295	MIMXRT1052DVL6A	600 MHz max	32 MByte	Yes	0 - 70 °C
EAC00306	MIMXRT1052CVL5A	528 MHz max	32 MByte	Yes	-40 - 85 °C
EAC00305	MIMXRT1052CVL5A	528 MHz max	No	Yes	-40 - 85 °C
EAC00308	MIMXRT1062CVL5A	528 MHz max	32 MByte	Yes	-40 - 85 °C
EAC00309	MIMXRT1062CVL5A	528 MHz max	No	Yes	-40 - 85 °C

[1] Standard configurations listed. Others on request. All configurations may not be stocked.

Support Highlights

Embedded Artists is a reliable and competent partner - we help you become successful!

- Professional and responsive support
- Carrier boards with reference implementations
- Custom Carrier board design
- Customization
 - Different pinning, supply voltage, memory sizes, etc
 - Single Board Computer (SBC) solutions
- Display solutions
- Mechanical solutions
- Schematic review of customer carrier board designs
- Driver and application development

Development Kit

The iMX RT1052/62 OEM Boards are supported by the **iMX RT1052/62 Developer's Kits** that provides a quick path to get started with development and integration work. The kits provides reference implementations of key interfaces. Ordering part No.

EAK00310 with iMX RT1062 and M.2 connector for Wi-Fi/BT (use this kit also for iMX RT1052 development).

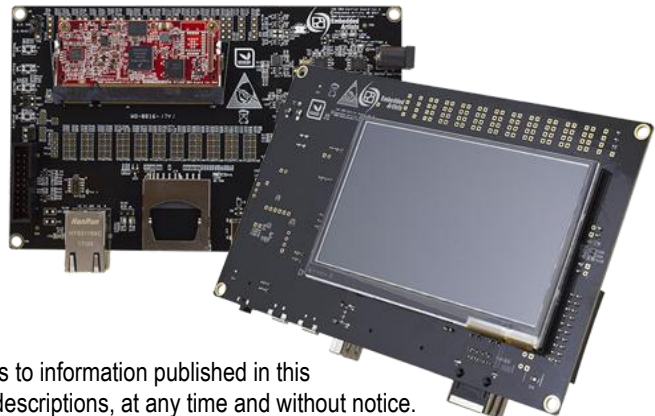

Disclaimer: Embedded Artists reserves the right to make changes to information published in this document, including without limitation specifications and product descriptions, at any time and without notice.