



INDUSTRIAL SHIELDS

USER GUIDE

PLC Arduino ARDBOX 20 I/Os Analog HF Modbus



Cat. Nº: ABOX-103-001-72



INDUSTRIAL SHIELDS



INDUSTRIAL SHIELDS

PLC Arduino ARDBOX 20 I/Os Analog HF User Guide

Revised August 2018

This user guide is for version PLC Arduino ARDBOX 20 I/Os Analog HF, ABOX-103-001-72 with Reference name Ref.IS.AB20AN-HF only. For older versions refer to user guide with Cat. No. ABOX-103-001-71



Preface

This User Guide is been implemented by Boot & Work, S.L. working under the name Industrial Shields.

Purpose of the manual

The information contained in this manual can be used as a reference to operating, to functions, and to the technical data of the signal modules, power supply modules and interface modules.

Intended Audience

This User Guide is intended for the following audience:

- Persons in charge of introducing automation devices.
- Persons who design automation systems.
- Persons who install or connect automation devices.
- Persons who manage working automation installation.



Warnings:

- Unused pins should not be connected. Ignoring the directive may damage the controller.
- Improper use of this product may severely damage the controller.
- Refer to the controller's User Guide regarding wiring considerations.
- Before using this product, it is the responsibility of the user to read the product's User Guide and all accompanying documentation.



Application Considerations and Warranty

Read and Understand this Manual

Please read and understand this manual before using the product. Please consult your comments or questions to Industrial Shields before using the product.

Application Consideration

THE PRODUCTS CONTAINED IN THIS DOCUMENT ARE NOT SAFETY RATED. THEY SHOULD NOT BE RELIED UPON AS A SAFETY COMPONENT OR PROTECTIVE DEVICE FOR ENSURING SAFETY OF PERSONS, AS THEY ARE NOT RATED OR DESIGNED FOR SUCH PURPOSES.

Please know and observe all prohibitions of use applicable to the products.

FOR AN APPLICATION INVOLVING SERIOUS RISK TO LIFE OR PROPERTY WITHOUT ENSURING THAT THE SYSTEM AS A WHOLE HAS BEEN DESIGNED TO ADDRESS THE RISKS, NEVER USE THE INDUSTRIAL SHIELDS PRODUCTS.

NEVER USE THE INDUSTRIAL SHIELDS PRODUCTS BEFORE THEY ARE PROPERLY RATED AND INSTALLED FOR THE INTENDED USE WITHIN THE OVERALL EQUIPMENT OR SYSTEM.

Industrial Shields shall not be responsible for conformity with any codes, regulations or standards that apply to the combination of products in the customer's application or use of the product.

The following are some examples of applications for which particular attention must be given. This is not intended to be an exhaustive list of all possible uses of the products, nor is it intended to imply that the uses may be suitable for the products:

- Systems, machines, and equipment that could present a risk to life or property.
- Nuclear energy control systems, combustion systems, railroad systems, aviation systems, medical equipment, amusement machines, vehicles, safety equipment, and installation subject to separate industry or government regulations.
- Outdoor use, uses involving potential chemical contamination or electrical interference, or conditions or uses not described in this document.

At the customer's request, INDUSTRIAL SHIELDS will provide applicable third party certification documents identifying ratings and limitations of use that apply to the products. This information by itself is not sufficient for a complete determination of the suitability of the products in combination with the system, machine, end product, or other application or use.



Disclaimers

Weights and Dimensions

Dimensions and weights are nominal and they are not used for manufacturing purposes, even when tolerances are shown.

Performance Data

The performance data given in this manual is provided as a guide for the user in determining suitability and does not constitute a warranty. It may represent the result of INDUSTRIAL SHIELDS's test conditions, and the users must correlate it to actual application requirements. Actual performance is subject to the INDUSTRIAL SHIELDS Warranty and Limitations of Liability.

Change in Specifications

Product specifications and accessories may be changed at any time based on improvements and other reasons.

It is our practice to change model numbers when features are changed, or published ratings or when significant construction changes are made. However, some specifications of the products may be changed without any notice. When in doubt, special numbers may be assigned to fix or establish key specifications for your application on your request. Please consult with your INDUSTRIAL SHIELDS representative at any time to confirm actual specifications of purchased products.

Errors and Omissions

The information in this document has been carefully checked and is believed to be accurate; however, no responsibility is assumed for clerical, typographical, or proofreading errors, or omissions.



Warranty and Limitations of Liability

Warranty

Industrial Shields's exclusive warranty is that the products are free from defects in materials and workmanship for a period of one year (or other period if specified) from date of sale by Industrial Shields.

INDUSTRIAL SHIELDS MAKES NO REPRESENTATION OR WARRANTY, EXPRESS OR IMPLIED, REGARDING MERCHANTABILITY, NON-INFRINGEMENT, OR FITNESS FOR PARTICULAR PURPOSE OF THE PRODUCTS. ANY BUYER OR USER ACKNOWLEDGES THAT THE BUYER OR USER ALONE HAS DETERMINED THAT THE PRODUCTS WILL SUITABLY MEET THE REQUIREMENTS OF THEIR INTENDED USE. INDUSTRIAL SHIELDS DISCLAIMS ALL OTHER WARRANTIES, EXPRESS OR IMPLIED

Limitations of Liability

INDUSTRIAL SHIELDS SHALL NOT BE RESPONSIBLE FOR SPECIAL, INDIRECT, OR CONSEQUENTIAL DAMAGES, LOSS OF PROFITS OR COMERCIAL LOSS IN ANY WAY CONNECTED WITH THE PRODUCTS, WHETHER SUCH CLAIM IS BASED ON CONTRACT, WARRANTY, NEGLIGENCE, OR STRICT LIABILITY.

IN NO EVENT SHALL INDUSTRIAL SHIELDS BE RESPONISBLE FOR WARRANTY, REPAIR OR OTHER CLAIMS REGARDING THE PRODUCTS UNLESS INDUSTRIAL SHIELDS'S ANALYSIS CONFIRMS THAT THE PRODUCTS WERE PROPERLY HANDLED, STORED, INSTALLED, AND MAINTAINED AND NOT SUBJECT TO CONTAMINATION, ABUSE, MISUSE, OR INAPPROPRIATE MODIFICATION OR REPAIR.



Table of Contents

Preface.....	4
1. Ardbox Analog HF: General Features.....	9
2. Precautions	10
2.1 Arduino Board	10
2.2 Intended Audience	10
2.3 General Precautions.....	10
3. Technical Specifications	11
3.1 General Specifications:.....	11
3.2 Performance Specification:	11
4. Software interface.....	12
5. How to connect PLC Arduino to PC.....	15
6. How to connect PLC to power supply	16
Din RAIL Power Supply, ac-dc, 30W, 1 Output 1.3A at 24Vdc	17
1. Din RAIL Power Supply, ac-dc, 30W, 1 Output 1.3A at 24Vdc	17
7. Ardbox Analog I/O pinout:	17
7.1 Zone Connections.....	17
8. Switch configuration	19
8.1 General Switches Configuration.....	19
8.2 RS- 485 Switch configuration	21
8.3 RS-232 Switch configuration	21
8.4 I2C Switch configuration	22
9. Jumper Configuration.....	22
General Jumper Configuration.....	22
10. Hardware Serial RS-232 & RS-485 Configuration.....	23
10.1 Hardware Serial RS-485.....	23
10.2 Hardware Serial RS-232.....	24
11. Ardbox - Arduino I/Os 5V pins.....	25
11.1 I2C pins – SDA/SCL	26
11.2 SPI – MISO/MOSI/SCK	26
12. I/O technical details	26
13. Typical Connections	29
14. Connector details	33
15. ARDBOX Family Dimensions:.....	34
16. DIN rail mounting:.....	34





1. Ardbox Analog HF: General Features

A compact PLC based in Open Source Hardware technology. With different Input/Outputs Units.



INDUSTRIAL SHIELDS



COMPACT PLC ARDUINO ARDBOX 20I/Os ANALOG HF			
Supply Voltage 24 Vcc	Supply Voltage	12 to 24Vdc	Fuse protection (2.5A) Polarity protection
	Max. current consumption	1,5A	
	Size	100x45x115	
	Clock Speed	16MHz	
Compact DIN rail mounting	Flash Memory	32KB of which 4KB are used by bootloader	
	SRAM	2.5KB	
	EEPROM	1KB	
	Communications	I2C -- USB -- RS232 -- RS485 -- SPI -- TTL	RS485
	TOTAL Input points	10	
	TOTAL Output points	10	
	INPUTS	Digital range: 12 to 24 Vdc (7.6 to 25.4 Vdc) Analog range: 0 to 10 Vdc	
	Digital	10	7 to 24Vdc I min: 3/6 mA Separated PCB ground
	Analog 10 bits	6	0 to 10V Input Impedance: 39K Separated PCB ground
	* Interrupt HS	1	7 to 24Vdc I min: 5/10 mA Separated PCB ground
 	OUTPUTS	Digital Isolated range: 5 to 24 Vdc (4.6 to 25.4 Vdc) Analog range: 0 to 10 Vdc	



Digital Isolated	10	5 to 24 Vdc I max: 70 mA Galvanic INSULATION Diode Protected for Relay
Analog 8 bits	7	0 to 10 Vdc I max: 20 mA Separated PCB ground
PWM Isolated 8bit	6 of 10 Digital isolated Output	5 to 24 Vdc I max: 70 mA Galvanic INSULATION Diode Protected for Relay
Expandability	I2C – RS232 – RS485 – SPI – TTL	
Reference	IS.AB20ANA.HF	

2. Precautions

2.1 Arduino Board

All Ardbox family PLCs include Arduino LEONARDO board.

2.2 Intended Audience

This manual is intended for technicians, which must have knowledge on electrical systems.

2.3 General Precautions

The user must operate the product according to the performance specifications described in the operation manuals.

Before using the product under conditions, which are not described in the manual or applying the product to nuclear control systems, railroad systems, aviation systems, vehicles, combustion systems, medical equipment, amusement machines, safety equipment and other systems, machines, and equipment that may have a serious influence on lives and property if used improperly, consult your INDUSTRIAL SHIELDS representative.

Make sure that the rating and performance characteristics of the product are sufficient for the systems, machines, and equipment, and be sure to provide the systems, machines, and equipment with double safety mechanisms.

This manual provides information for programming and operating the Unit. Be sure to read this manual before attempting to use the Unit. Keep this manual close at hand for reference during operation.



3. Technical Specifications

3.1 General Specifications:

Power supply voltage	DC power supply	12 to 24Vdc
Operating voltage range	DC power supply	11.4 to 25.4Vdc
Power consumption	DC power supply	30VAC max.
External power supply	Power supply voltage	12 to 24Vdc
	Power supply output capacity	1.3A
Insulation resistance		20MΩ min. at 500Vdc between the AC terminals and the protective ground terminal.
Dielectric strength		2.300 VAC at 50 to 60 Hz for one minute with a leakage current of 10mA max. Between all the external AC terminals and the protective earth terminal.
Shock resistance		80m/s ² in the X, Y and Z direction 2 times each.
Ambient temperature (operating)		0° to 45°C
Ambient humidity (operating)		10% to 90% (no condensation)
Ambient environment (operating)		With no corrosive gas
Ambient temperature (storage)		-20° to 60°C
Power supply holding time		2ms min.
Weight		340g max.

3.2 Performance Specification:

Arduino Board	ARDUINO LEONARDO
Control method	Stored program method
I/O control method	Combination of the cyclic scan and immediate refresh processing methods.
Programming language	Arduino IDE. Based on wiring (Wiring is an Open Source electronics platform composed of a programming language. "similar to the C". http://arduino.cc/en/Tutorial/HomePage
Microcontroller	ATmega32u4
Flash Memory	32KB of which 4KB are used by bootloader
Program capacity (SRAM)	2.5KB
EEPROM	1KB
Clock Speed	16MHz



4. Software interface

Industrial Shields PLC are programmed using Arduino IDE, which is a software based on the C language. They can also be programmed using directly C but it is much easier working with Arduino IDE as it provides lots of libraries that helps in the programming.

Furthermore Industrial Shields provides boards for programming the PLCs much easier. Basically it is no needed to define the pins and if that pins are inputs or outputs. Everything is set up automatically if using the boards.

In order to install Industrial Shields boards, these are the steps that must be followed.

Requirements:

Arduino IDE 1.8.0 or above (better to have always the latest version).

Steps:

1. Open Arduino IDE and go to: "File -> Preferences" located in the top left corner.

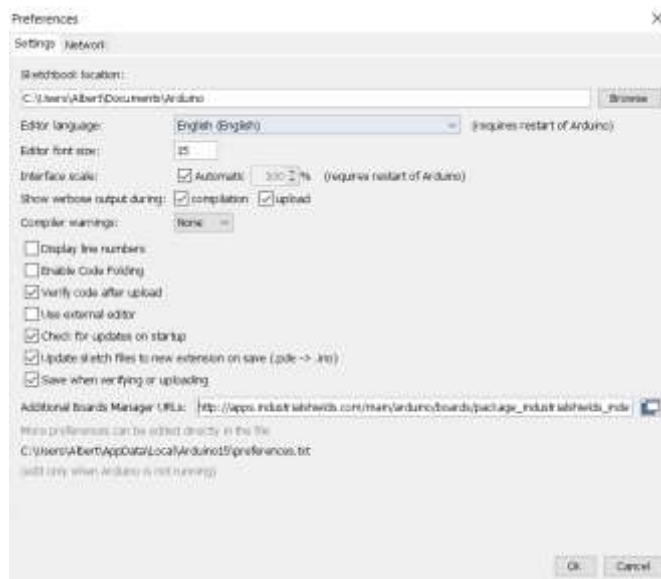

2. In Additional Boards URLs write the following:

http://apps.industrialshields.com/main/arduino/boards/package_industrialshields_index.json



3. Press OK to save the changes.
4. Go to: Tools -> Board: ... -> Boards Manager



5. Search for industrialshields on the searcher.

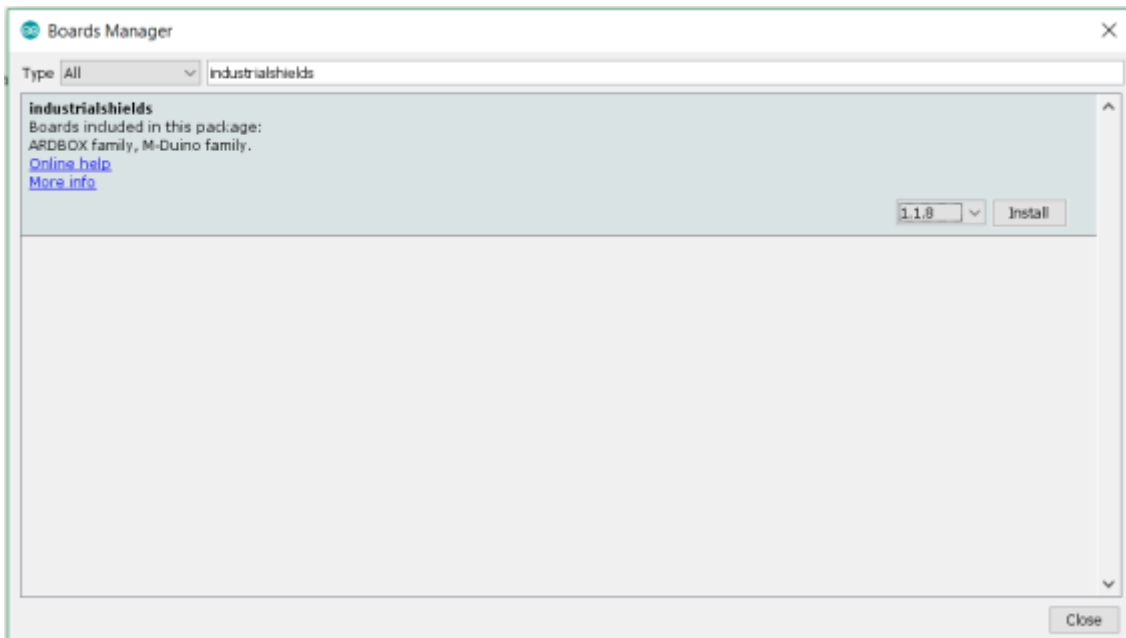

6. Click install (selecting the latest version).

Following this steps you will be able to use now the Industrial Shields Boards:

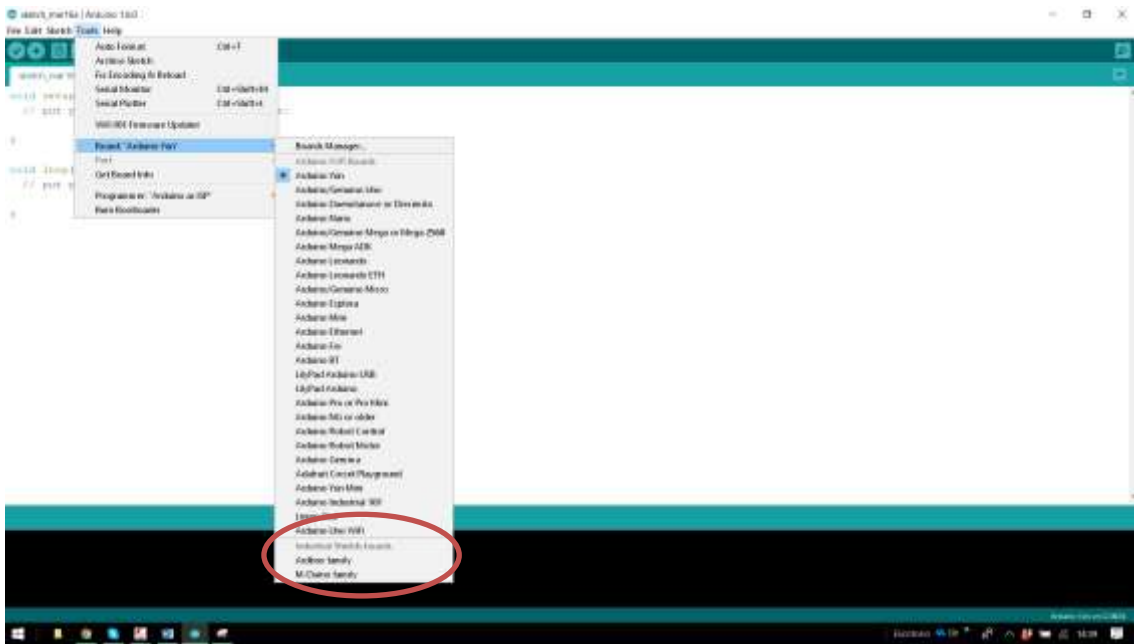

Once it is selected the Ardbox Family or M-Duino family an extra option will appear on Tools:

There, it can be selected the exact model for every family.

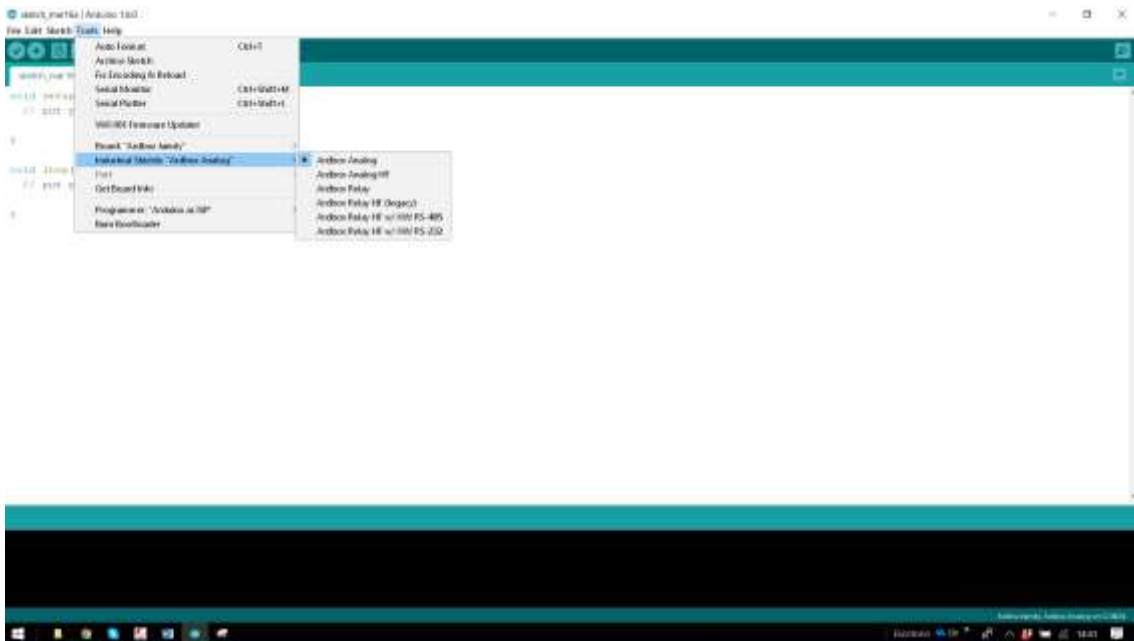

Also there are some examples of programming in File -> Examples -> Ardbox Family.

Furthermore there are some extra libraries that can be found in Industrial Shields github.

<https://github.com/IndustrialShields/>



5. How to connect PLC Arduino to PC

- Connect USB port from PLC to PC.

NOTE:

Ardbox Family uses micro USB cable.



- Open Arduino IDE interface:
- Select Industrial Shields boards -> Ardbox Family
- Select the correct Ardbox Analog Board.

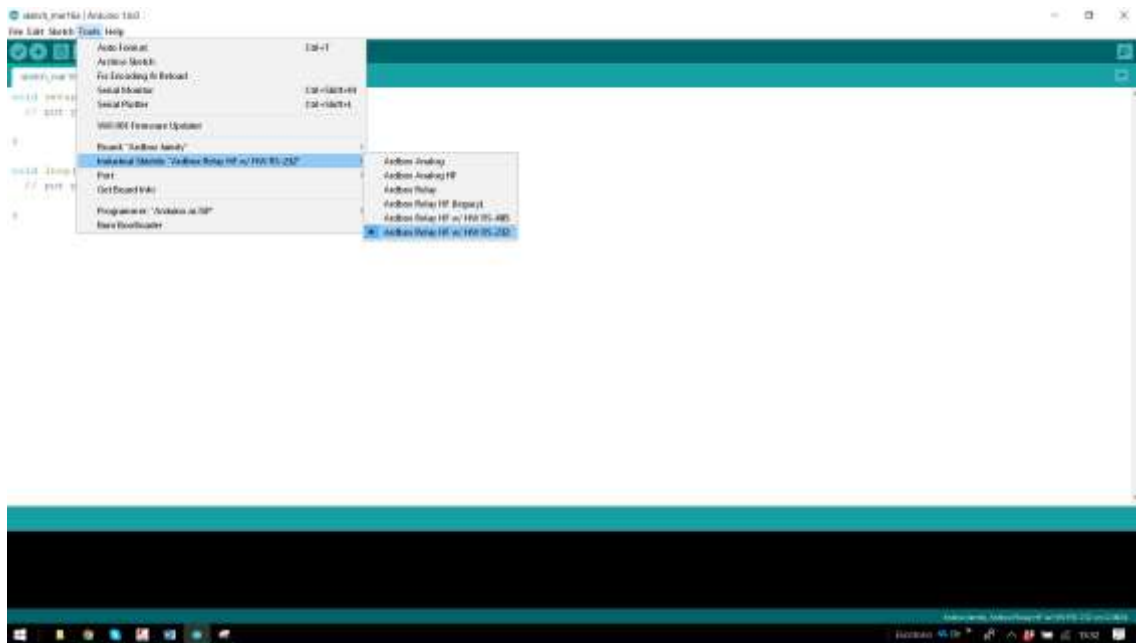

If it is used the latest version of Industrial Shields boards it will appear 4 different Ardbox Analog boards:

The ones that have to be used for the 103-002-72 Ardbox Analog HF are the following ones:

- Ardbox Analog HF w/ HW RS-485
- Ardbox Analog HF w/ HW RS-232

* HW is the abbreviation of Hardware, so depending on the Hardware Serial that will be used, it is needed to select one or the other. See section 10 to configure the equipment to work with RS-232 Hardware Serial or RS-485 Hardware Serial.

If it is not used the RS-232 & RS-485 it is needed to select the board Ardbox Analog HF w/ HW RS-485. See section 8 to enable the features that are disabled when using RS-485 protocol that will get enabled as there is no RS-485/RS-232 protocol.



- Select correct port.

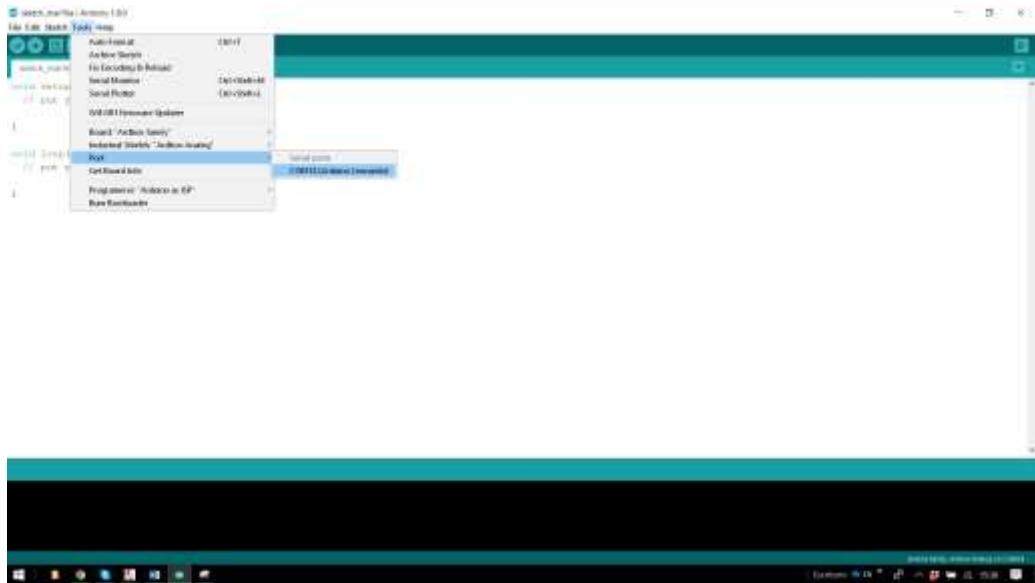

Now everything is set up to upload a sketch to Ardbox Relay HF

6. How to connect PLC to power supply

- Ardbox Family PLCs are 12-24Vdc supplied. **IMPORTANT: The polarity IS NOT REVERSAL!**
- Make sure that the live and GND connector of the power supply match the PLC.
- Make sure that the power supply mains output is not higher than 24Vdc.

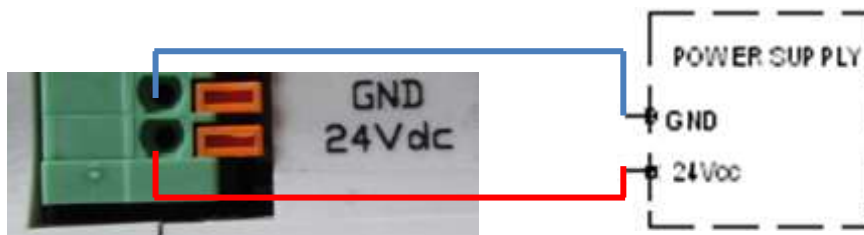



- Suggested power suppliers



* Not recommended for industrial applications. The *Jack* connector needs to be removed and use the live and GND connectors.



Din RAIL Power Supply, ac-dc, 30W, 1 Output 1.3A at 24Vdc

7. Ardbox Analog I/O pinout:

7.1 Zone Connections

LEFT ZONE		
Ardbox Connector	Arduino Pin	Function
A0.6 ¹	3	Analog Out
A0.5 ¹	5	Analog Out
A0.4 ¹	6	Analog Out
A0.3 ¹	9	Analog Out
A0.2 ¹	10	Analog Out
A0.1 ¹	11	Analog Out
A0.0 ¹	13	Analog Out
Q0.9 ²	4	Digital Output
Q0.8 ²	8	Digital Output
Q0.7	12	Digital Output
Q0.6 ¹	3	PWM/digital Output
Q0.5	5	PWM/digital Output
Q0.4	6	PWM/digital Output
Q0.3	9	PWM/digital Output
Q0.2	10	PWM/digital Output
Q0.1	11	PWM/digital Output
Q0.0	13	PWM/digital Output
GNDCOM	-	Isolated GND
24VCOM	-	Isolated VIN

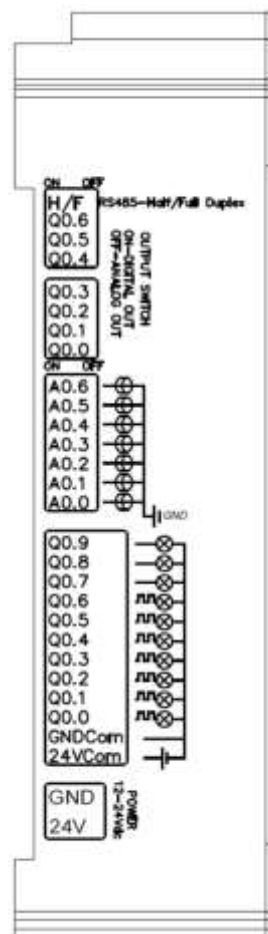

LEFT ZONE

Switch config*
(see section 8 for Communications configuration. Enabling Communications disables some I/Os)

Analog Outputs pins

Digital Outputs pins

Power supply connectors (24Vdc – GND)

¹ See section 8 to enable these connections

² See section 9 to enable these connections



RIGHT ZONE			
Ardbox Connector	Arduino Pin RS232 HS*	Arduino Pin RS485 HS*	Function
A+ ^{1,2}	-	-	RS485(A)
B+ ^{1,2}	-	-	RS485(B)
Y+ ^{1,2}	-	-	RS485(Y)
Z+ ^{1,2}	-	-	RS485(Z)
SCL-PIN3 ¹	3	3	SCL(I2C)
SDA-PIN2 ¹	2	2	SDA(I2C)
TX-RS232 ^{1,2}	1	4	-
RX-RS232 ^{1,2}	0	8	-
5V	-	-	5Vout DC
RESET	-	-	RESET
SCK	-	-	SPI
MOSI	-	-	SPI
MISO	-	-	SPI
I0.9	18	18	Analog/Digital Input
I0.8	19	19	Analog/Digital Input
I0.7	20	20	Analog/Digital Input
I0.6	21	21	Analog/Digital Input
I0.5	22	22	Analog/Digital Input
I0.4	23	23	Analog/Digital Input
I0.3 ¹	0	0	Digital Input
I0.2 ¹	1	1	Digital Input
I0.1	7	7	Digital Input
I0.0 ¹	2	2	Digital interrupt

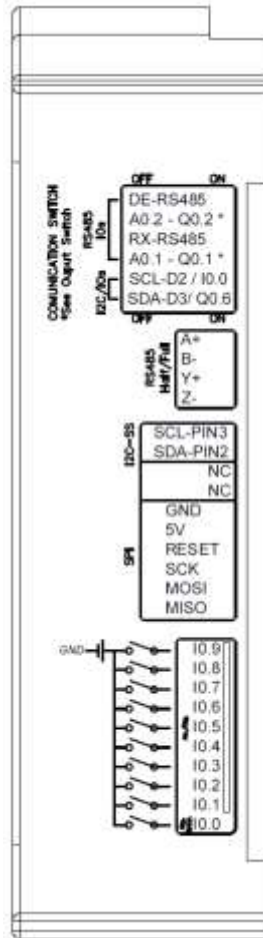

LEFT ZONE

Switch config*

(see section 8 for Communications configuration. Enabling Communications disables some I/Os)

Communications pins

Digital/Analog Inputs

HS*: Hardware Serial
SS*: Software Serial

¹ See section 8 to enable these connections

² See section 9 to enable these connections

NOTE: Although in the serigraphy it is not shown the RS232 communication pins, in the reality it exists. The change that has to be done is the following:

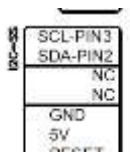

DEFAULT SERIGRAPHY	CORRECT SERIGRAPHY
SDA-PIN2	SDA-PIN2
NC	TX-RS232
NC	RX-RS232
GND	GND

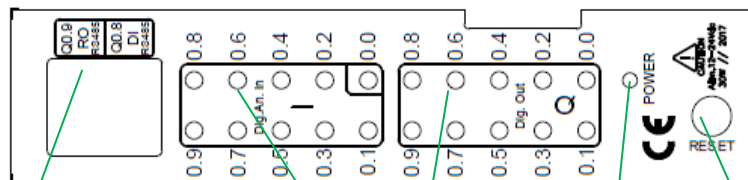

Config switch *
(see section 8 for communications configuration)

Input / Output

Power LED

Arduino Reset button



NOTE: Although in the TOP ZONE serigraphy it is shown Q0.9 & Q0.8 pins, in the reality they are I0.3 I0.2 pins respectively. Additionally although the serigraphy only is expressed for the RS485 it is also the same for the RS232. So if it is desired to enable any of the Hardware Serial connection this is the function of these switches. See chapter 8 for more information

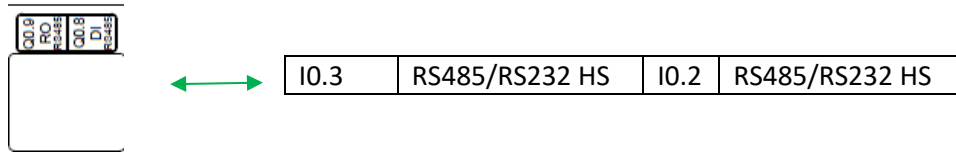

8. Switch configuration

8.1 General Switches Configuration

LEFT ZONE.

Communications and inputs/outputs can not work simultaneously.

LEFT ZONE		
SWITCH	OFF	ON
DE-RS485	A0.2-Q0.2*	DE-RS485
D10/A0.2-Q0.2	DE-RS485	A0.2-Q0.2
RE-RS485*	A0.1-Q0.1*	RE-RS485
D11/A0.1-Q0.1	RE-RS485	A0.1-Q0.1*
SDA-D2/I0.0*	SDA-D2	I0.0
SCL-D3/Q0.6*	SCL-D3	Q0.6

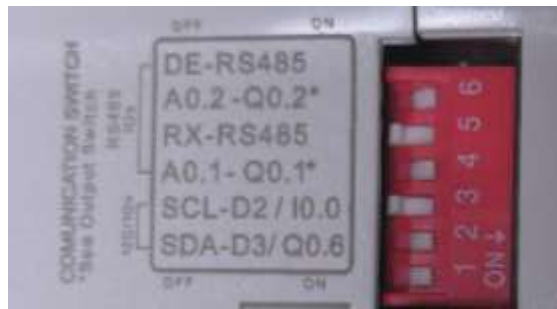

*I2C switch serigraphy is turned around. It should be: (SDA-D2 , SCL-D3). RX-RS485 should be RE-RS485

6. DE-RS485 – If this switch is ON, the A0.2-Q0.2 switch must be set to OFF. Being in ON mode it enables DE for the RS-485.
5. A0.2-Q0.2 – If this switch is ON, the DE-RS485 switch must be set to OFF. Being in ON mode it enables the outputs A0.2-Q0.2.
4. RE-RS485 – If this switch is ON, the A0.1-Q0.1 switch must be set to OFF. Being in ON mode it enables EE for the RS-485.
3. A0.1-Q0.1 – If this switch is ON, the RE-RS485 switch must be set to OFF. Being in ON mode it enables the outputs A0.1-Q0.1.
2. SDA-D2/I0.0 – Choosing between SDA (I2C) and I0.0. If this switch is ON, the I0.0 input will be enabled and the SDA will be disabled. If this switch is OFF, the SDA will be now available and I0.0 disabled
1. SCL-D3/Q0.6 – Choosing between SCL (I2C) and Q0.6. If this switch is ON, the Q0.6 input will be enabled and the SCL will be disabled. If this switch is OFF, the SCL will be now available and Q0.6 disabled.



TOP ZONE.

TOP ZONE		
SWITCH	OFF	ON
I0.3	RS485/RS232 HS	I0.3
RS485/RS232 HS	I0.3	RS485/RS232 HS
I0.2	RS485/RS232 HS	I0.2
RS485/RS232 HS	I0.2	RS485/RS232 HS



NOTE: Although in the TOP ZONE serigraphy it is shown Q0.9 & Q0.8 pins, in the reality they are I0.3 I0.2 pins respectively. Additionally although the serigraphy only is expressed for the RS485 it is also the same for the RS232. So if it is desired to enable any of the Hardware Serial connection this is the function of these switches. See chapter 8 for more information

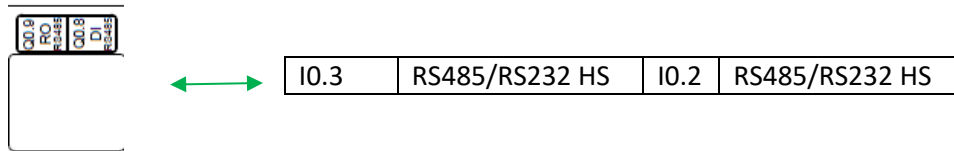

1. I0.3: If this switch is ON, the RS485/RS232 HS switch must be set to OFF. Being in ON mode it enables I0.3.
2. RS485/RS232 HS: If this switch is ON, the I0.3 switch must be set to OFF. Being in ON mode it enables the D0 for the RS-485 or RS-232 Hardware Serial (see section 9 for jumper configuration)
3. I0.2: If this switch is ON, the RS485 switch must be set to OFF. Being in ON mode it enables I0.2.
4. RS485/RS232 HS: If this switch is ON, the I0.2 switch must be set to OFF. Being in ON mode it enables the D1 for the RS485 or RS-232 Hardware Serial (see section 9 for jumper configuration)

RIGHT ZONE

RIGHT ZONE		
SWITCH	OFF	ON
H/F	Full Duplex	Half Duplex
Q0.6	ANALOG (A0.6)	DIGITAL (Q0.6)
Q0.5	ANALOG (A0.5)	DIGITAL (Q0.5)
Q0.4	ANALOG (A0.4)	DIGITAL (Q0.4)
Q0.3	ANALOG (A0.3)	DIGITAL (Q0.3)
Q0.2	ANALOG (A0.2)	DIGITAL (Q0.2)
Q0.1	ANALOG (A0.1)	DIGITAL (Q0.1)
Q0.0	ANALOG (A0.0)	DIGITAL (Q0.0)

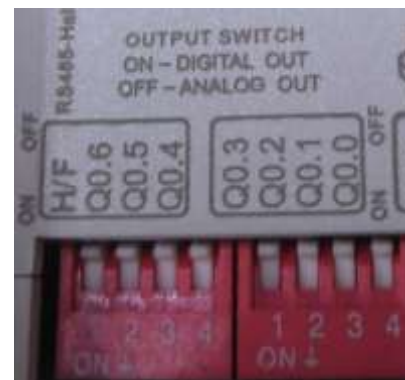

RIGHT ZONE. The right zone configures the outputs. If the switch is set to "ON" the Q0.X will have the behaviour of a digital output. If it is set to "OFF" it will be analog. There is also a switch for switching between Half and Full Duplex. It is "ON" for Half Duplex and "OFF" for Full Duplex.



8.2 RS- 485 Switch configuration

TOP ZONE	
SWITCH	MODE
I0.3	OFF
RS485 HS	ON
I0.2	OFF
RS485 HS	ON

RS-485 TOP ZONE: In order to enable the RS-485 protocol the TOP ZONE must be configured as it is shown in the table.

Although the switch serigraphy is only referenced to RS-485 it is also the for the RS-232.

Having this setup, the I0.3 & I0.2 are disabled

LEFT ZONE	
SWITCH CONFIGURATION	
SWITCH	MODE
DE-RS485	ON
D10/A0.2-Q0.2	OFF
RE-RS485	ON
D11/A0.1-Q0.1	OFF
SDA-D2/I0.0	-
SCL-D3/Q0.6	-

RS-485 LEFT ZONE: In order to enable the RS-485 communication protocol it is necessary that the switches of the left zone are configured as it is showed in the table.

The ones marked with “-“ mean that they don’t affect the RS-485 communication protocol

8.3 RS-232 Switch configuration

TOP ZONE	
SWITCH	MODE
I0.3	OFF
RS232 HS	ON
I0.2	OFF
RS232 HS	ON

RS-232 TOP ZONE: In order to enable the RS-232 communication protocol it is necessary that the switches of the top zone are configured as it is shown in the table.

Although the nomenclature is not referenced to the RS-232, this switches relates the hardware serial of the Arduino board.

LEFT ZONE	
SWITCH	MODE
DE-RS485	OFF
D10/A0.2-Q0.2	ON
RE-RS485	OFF
D11/A0.1-Q0.1	ON
SDA-D2/I0.0	-
SCL-D3/Q0.6	-

RS-232 LEFT ZONE: In order to enable the RS-232 communication protocol it is necessary that the switches of the left zone is configured as it is showed in the table.

The ones marked with “-“ mean that it does not affect the RS-232 communication protocol



8.4 I2C Switch configuration

TOP ZONE	
SWITCH	MODE
I0.3	-
RS485/RS232 HS	-
I0.2	-
RS485/RS232 HS	-

LEFT ZONE	
SWITCH	MODE
DE-RS485	-
D10/A0.2-Q0.2	-
RE-RS485	-
D11/A0.1-Q0.1	-
SDA-D2/I0.0	OFF
SCL-D3/Q0.6	OFF

I2C: Enable SCL and SDA connections (direct Arduino pins) with configuration switches. I0.0 and Q0.6 will not be available. In order to implement this communication a 4.7k Ω pull-up resistor ([IS.AC12C-4.7K](#)) is required.

9. Jumper Configuration

General Jumper Configuration

JUMPER ZONE 1	
LEFT	RIGHT
RS-485	RS-485
D0	D1
RS-232	RS-232

This jumper makes the choosing between connecting MAX232 to pins 0,1 of the Arduino Leonardo or with the MAX485. In order to use the RS-232 Hardware Serial protocol both RS-232 must be connected to the D1/D0. In order to use the RS-485 Hardware Serial protocol both RS-485 must be connected to the D1/D0.

JUMPER ZONE 2	
LEFT	RIGHT
I0.2	I0.3
D4	D8
RS-232 SS	RS-232 SS

This jumper zone makes the choosing between connecting the inputs I0.2, I0.3 to pins 4 and 8 of the Arduino Leonardo respectively, or connect the RS-232 ports to activate the Software Serial RS-232. In order to use the inputs I0.2,I0.3 the jumper must be connected to the pins 4 and 8. So I0.2 must be connected with D4 and I0.3 must be connected to D8.

*The jumpers that are not connected to the middle jumpers **MUST NOT** be Connected anywhere.

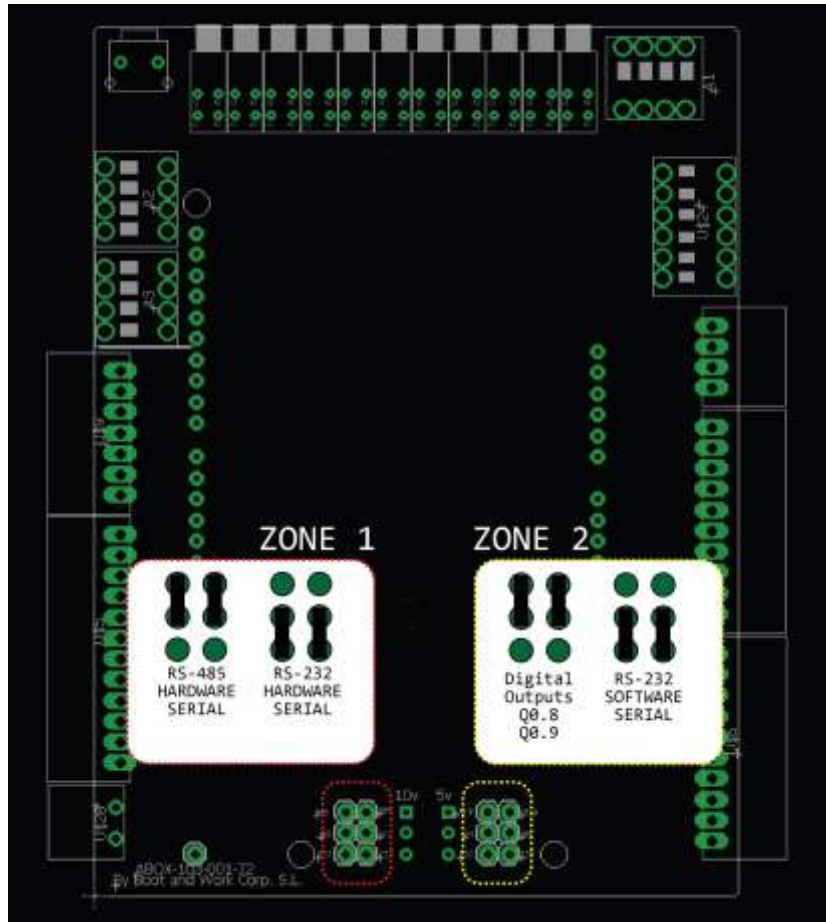

10. Hardware Serial RS-232 & RS-485 Configuration

10.1 Hardware Serial RS-485

In order to enable the Hardware Serial RS-485 the total configuration of the Ardbox Analog HF will be:

Switch configuration:

TOP ZONE	
SWITCH	MODE
I0.3	OFF
RS485 HS	ON
I0.2	OFF
RS485 HS	ON

LEFT ZONE	
SWITCH	MODE
DE-RS485	ON
D10/A0.2-Q0.2	OFF
RE-RS485	ON
D11/A0.1-Q0.1	OFF
SDA-D2/I0.0	-
SCL-D3/Q0.6	-



Jumper configuration:

JUMPER ZONE 1	
LEFT	RIGHT
RS-485	RS-485
D0	D1
-	-

JUMPER ZONE 2	
LEFT	RIGHT
I0.2	I0.3
D4	D8
-	-

Having configured Ardbox Analog HF as it is shown above, these are the features that are available:

- Available communication protocols:
 - Hardware Serial RS-485.
 - I2C *If I2C is active I0.0 & Q0.6 are disabled
 - SPI
 - TTL
 - USB
- Inputs: 8 out of 10 inputs, I0.0, I0.1 and I0.4 to I0.9. If using I2C I0.0 is also disabled
- Digital Outputs: All 10 outputs. If using I2C Q0.6 is disabled.
- Analog Outputs: From A0.0 to A0.6. If using I2C A0.6 is disabled

10.2 Hardware Serial RS-232

In order to enable the Hardware Serial RS-232 the total configuration of the Ardbox Relay HF will be:

Switch configuration:

TOP ZONE	
SWITCH	MODE
I0.3	OFF
RS232 HS	ON
I0.2	OFF
RS232 HS	ON

LEFT ZONE	
SWITCH	MODE
DE-RS485	OFF
D10/A0.2-Q0.2	ON
RE-RS485	OFF
D11/A0.1-Q0.1	ON
SDA-D2/I0.0	-
SCL-D3/Q0.6	-

Note: The switches of the left zone of the RS-485 don't interfere in the RS-232 HS, the thing is that as pins 0 & 1 are reserved for the RS-232, the RS-485 is totally disabled. As it is disabled, there is no point on configuring these switches as RS-485 mode



Jumper configuration:

JUMPER ZONE 1 HALF DUPLEX	
LEFT	RIGHT
-	-
D0	D1
RS-232	RS-232

JUMPER ZONE 2	
LEFT	RIGHT
I0.2	I0.3
D4	D8
-	-

- Available communication protocols:
 - Hardware Serial RS-232.
 - I2C *If I2C is active I0.0 & Q0.6 are disabled
 - SPI
 - TTL
 - USB
- Inputs: 8 out of 10 inputs, I0.0, I0.1 and I0.4 to I0.9. If using I2C I0.0 is also disabled
- Digital Outputs: All 10 outputs. If using I2C Q0.6 is disabled.
- Analog Outputs: From A0.0 to A0.6. If using I2C A0.6 is disabled

11. Ardbox - Arduino I/Os 5V pins

The Ardbox has some of the Mega board pins available. These pins can be programmed according to Arduino features such as I/Os operating at 5V or any additional features present in the pins (for example I2C communication in pins SCL and SDA). As this pins are directly connected to the Arduino Mega board they are not as well protect as the normal inputs. These pins are mainly meant to be used as prototyping.

M-Duino terminal	Arduino pin
SCL – Pin 3	3
SDA – Pin 2	2
MISO	14
SCK	15
MOSI	16

***IMPORTANT:** Do not connect the terminals in the chart above to voltages higher than 5V. These terminals provide direct access to the Mega board.

A part from the switch configuration there are some special conditions depending on these 5V. Now it is going to be shown the considerations to operate with these pins.



11.1 I2C pins – SDA/SCL

The I2C protocol is meant to work in a pull-up configuration. The I2C pins in the Arduino Leonardo are not pull-up, so in order to work with the I2C an external pull-up resistor is required. If it is meant to work as a GPIO at 5V, the switches must be set as I2C, (section 8).

These pins are not established with a pull-up or a pull-down configuration. The state of these pins is unknown. If these pins must be used they require a pull-up or a pull-down configuration. The Arduino board allows the pins to be set in a pull-up configuration. If not it must be established an external pull-up or pull-down circuit in order to correctly work with these pins.

11.2 SPI – MISO/MOSI/SCK

These pins can only work as a 5V pins. As the Ardbox family does not implement the Ethernet protocol, these pins can always work as a 5V pins.

These pins are not established with a pull-up or a pull-down configuration. The state of these pins is unknown. If these pins must be used, they require a pull-up or a pull-down configuration. The Arduino board allows the pins to be set in a pull-up configuration. If not it must be established an external pull-up or pull-down circuit in order to correctly work with these pins.

12. I/O technical details

Digital Output Waveform

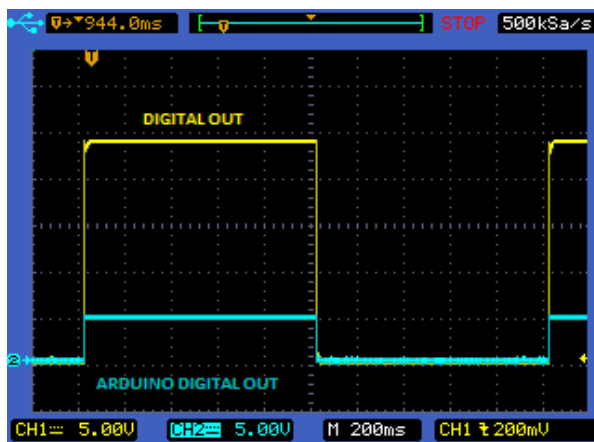

Digital Output Turn-off

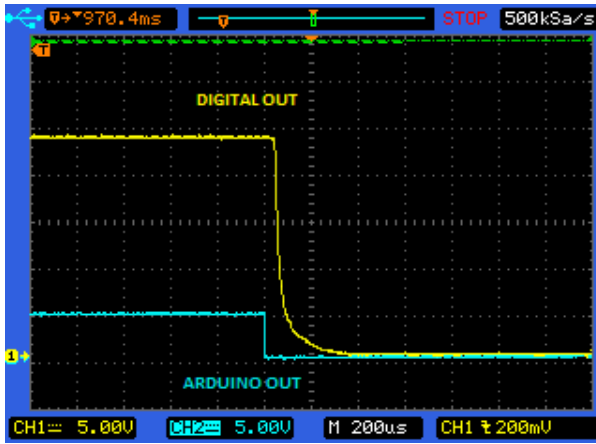

PWM Waveform

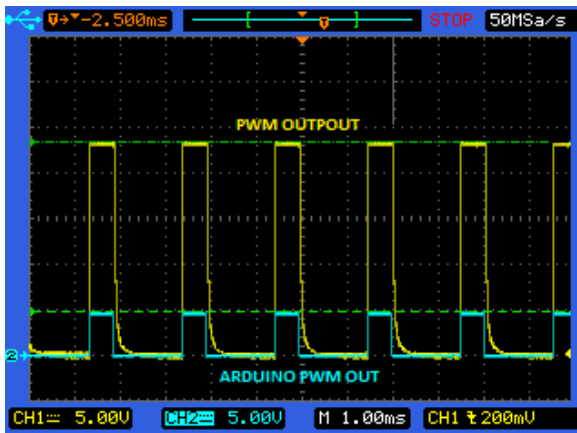

Analog Out Turn-on

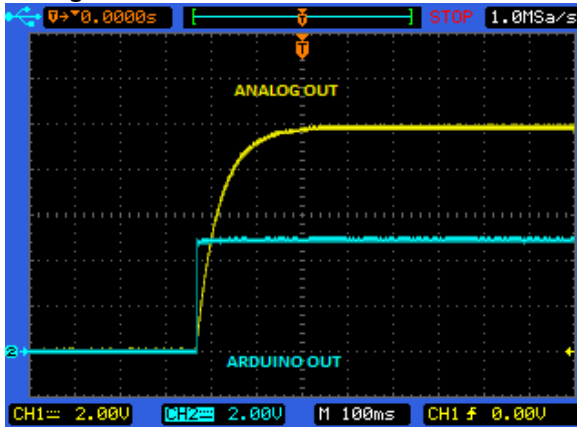



Analog Out Turn-off

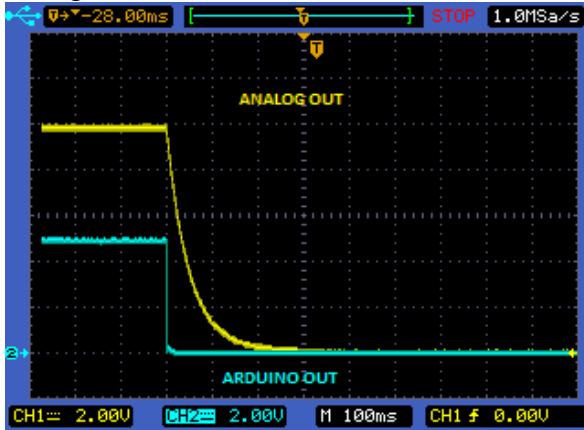

Analog/Digital Input Turn-on

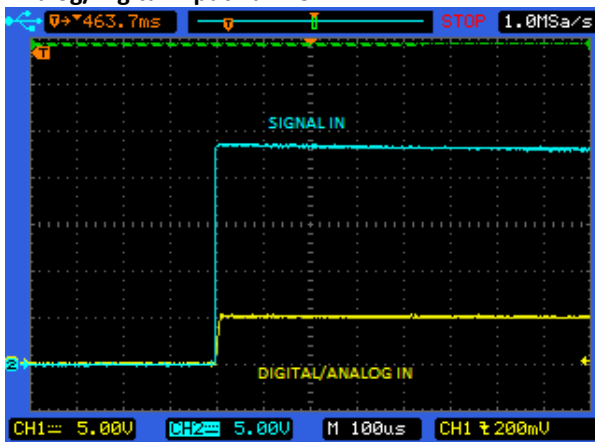

Analog/Digital Input Turn-off

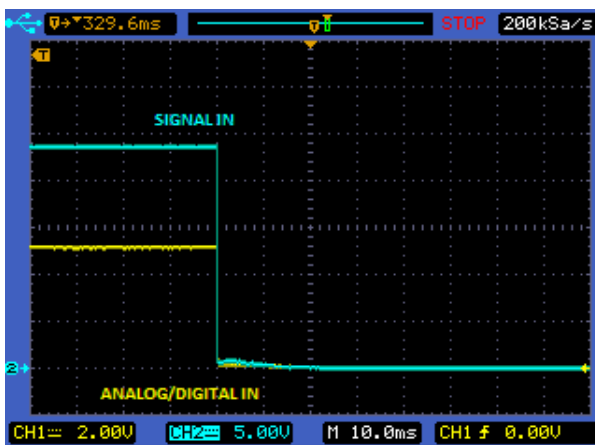



13. Typical Connections

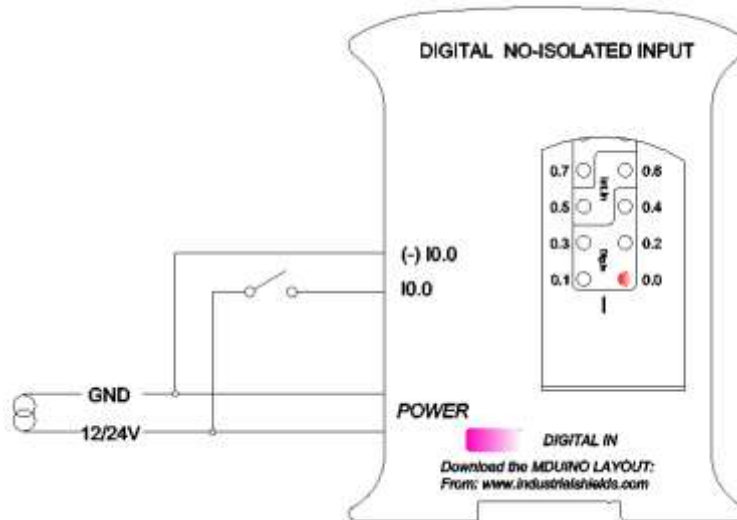
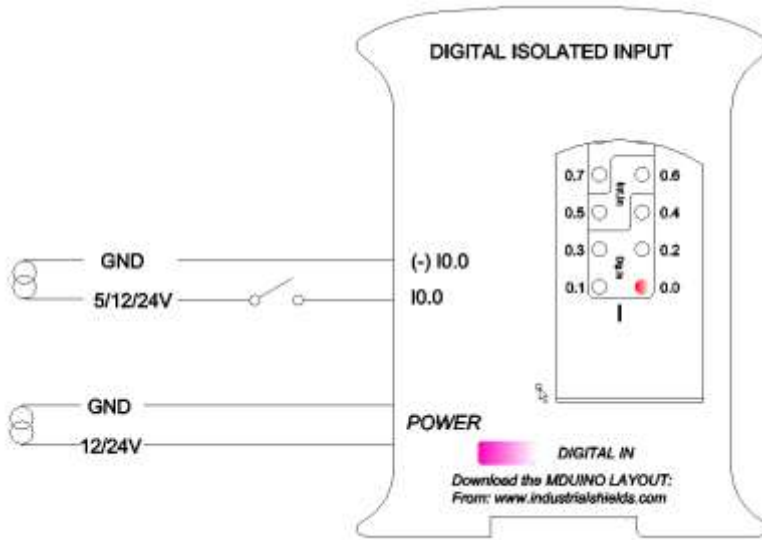

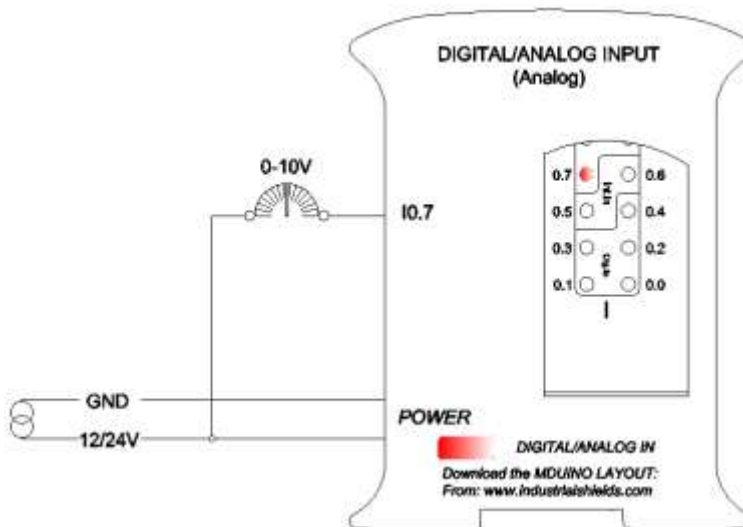
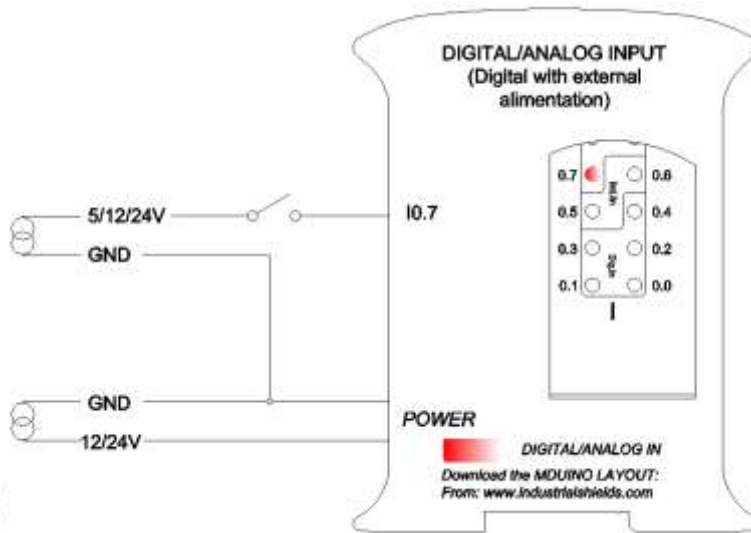
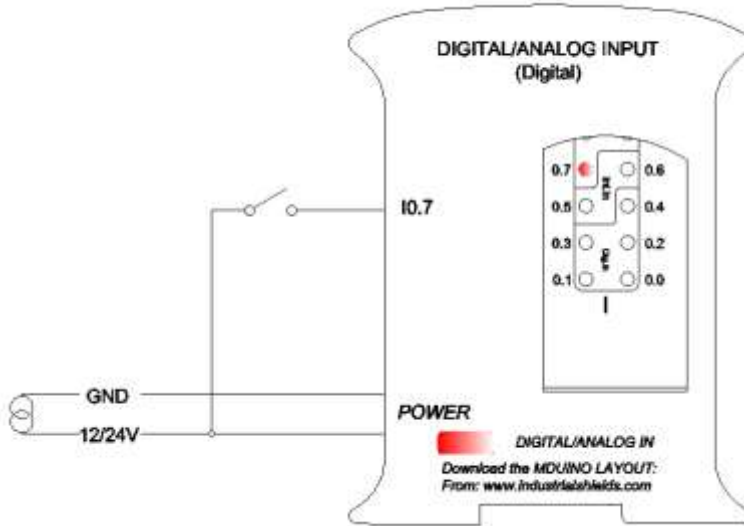

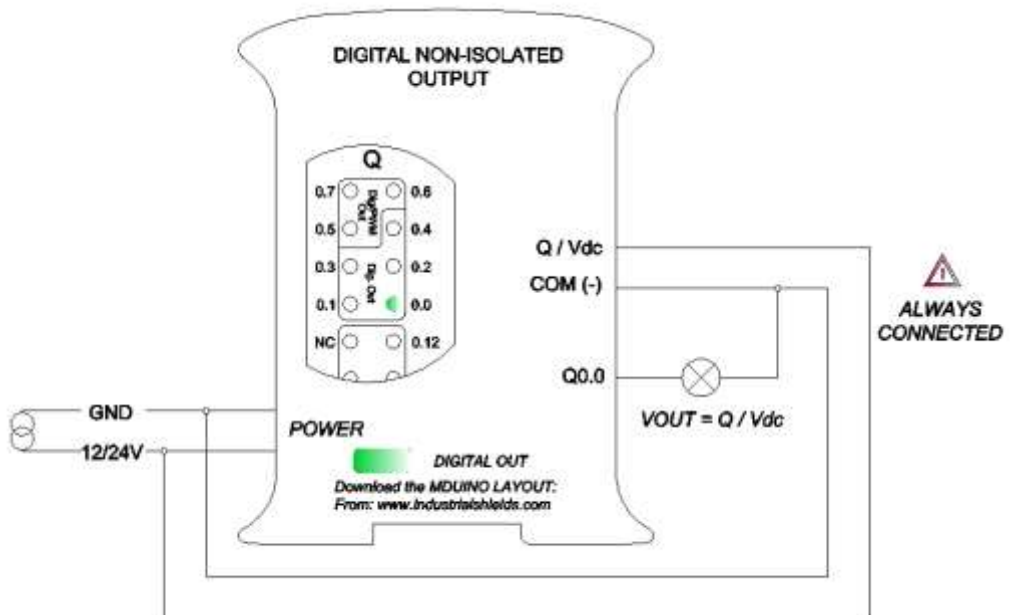
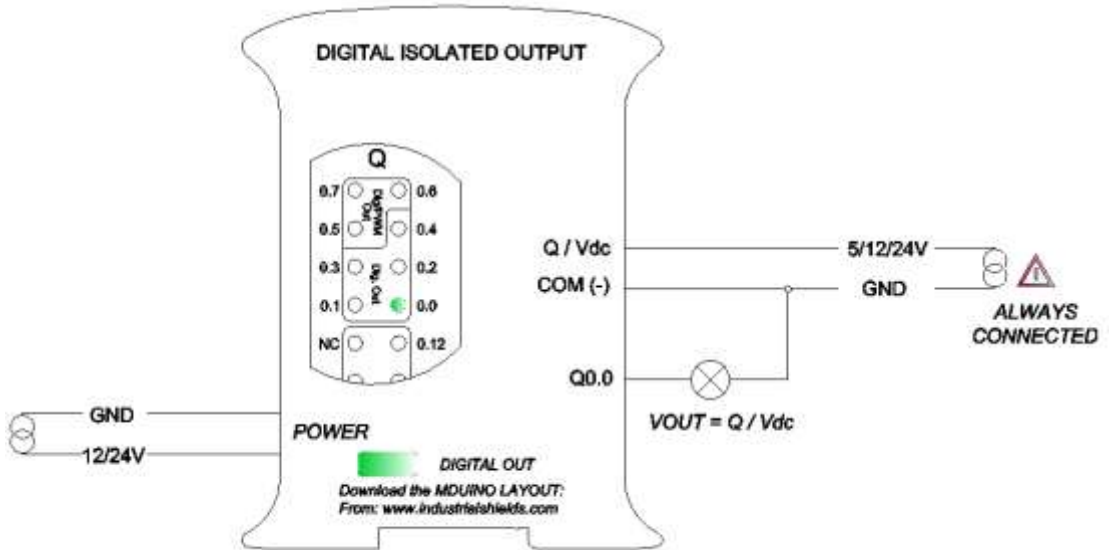
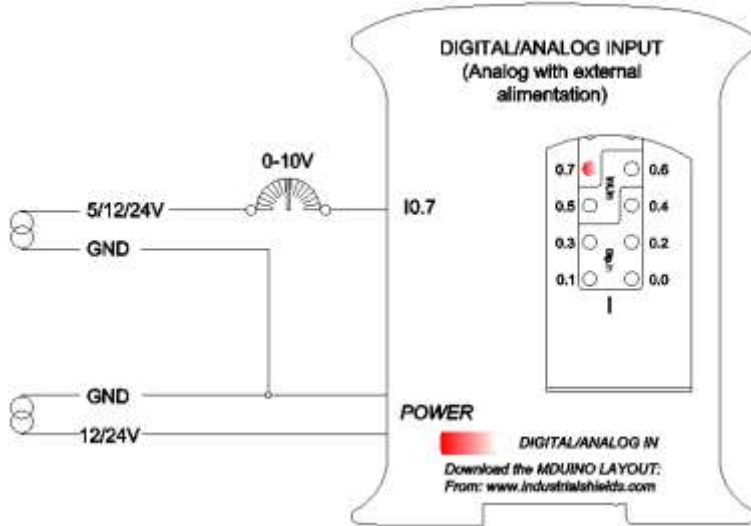

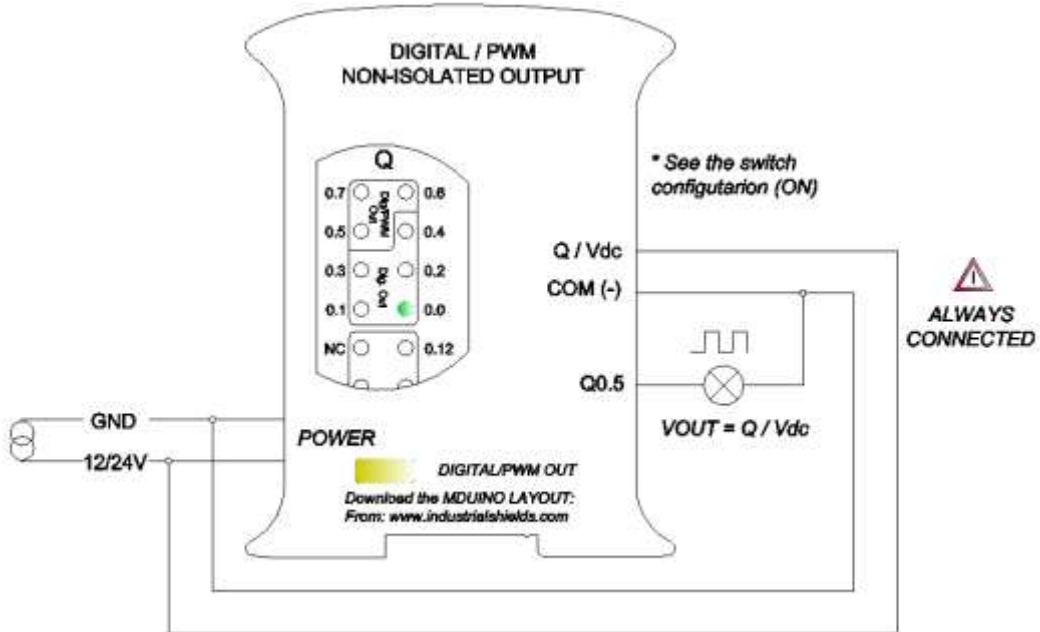
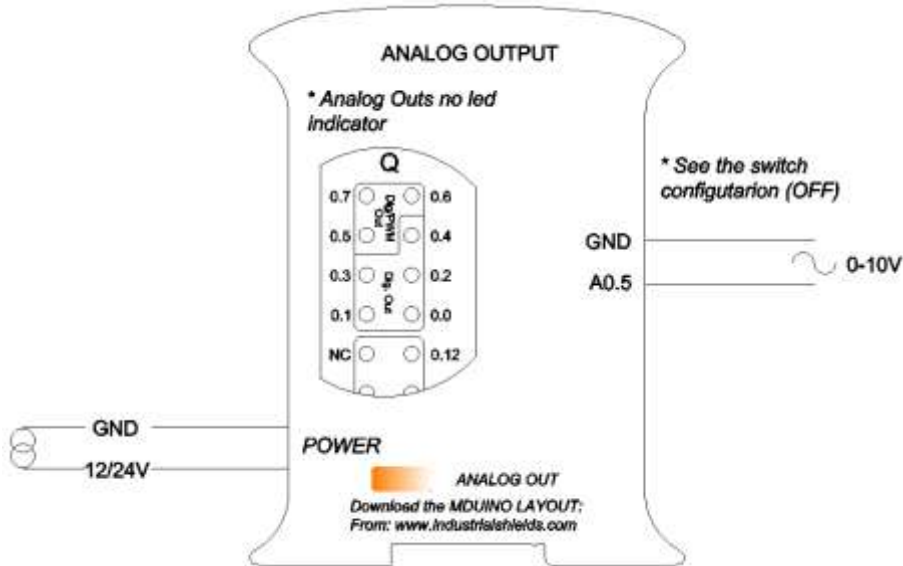
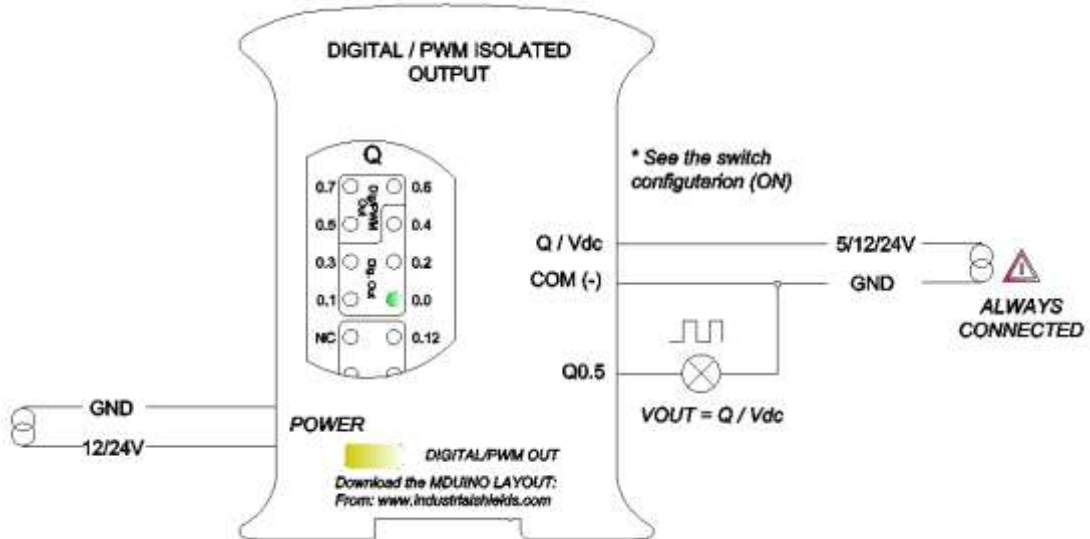



14. Connector details

The connector inside the PLCs that mounts on the PCB is MC 0,5/10-G-2,5 THT – 1963502 from Phoenix contact. MC0,5/10-G-2,5THT

For I/O and power supply there is a FK-MC 0,5/10-ST-2,5 - 1881406 connector from Phoenix contact. FK-MC 0,5/10-ST-2,5

Connection details:

Article reference	MC 0,5/10-G-2,5 THT
Height	8,1mm
Pitch	2,5mm
Dimension	22,5mm
Pin dimensions	0,8x0,8mm
Pin spacing	2,50mm



Article reference	FK-MC 0,5/10-ST-2,5
Rigid conduit section min.	0,14 mm ²
Rigid conduit section max.	0,5 mm ²
Flexible conduit section min.	0,14 mm ²
Flexible conduit section max.	0,5 mm ²
Conduit section AWG/kcmil min.	26
Conduit section AWG/kcmil max.	20





15. ARDBOX Family Dimensions:

16. DIN rail mounting:

17.

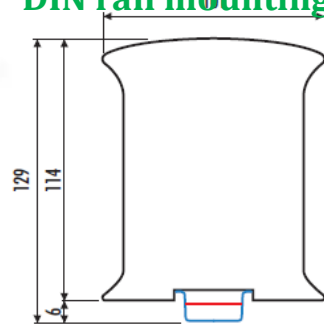

45mm width

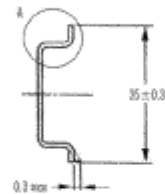

Profilato a cappello TH 35-7,5
Top hat rail TH 35-7.5

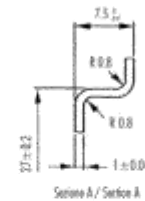

Sezione A / Section A

Profilato a cappello TH 35-15
Top hat rail TH 35-15

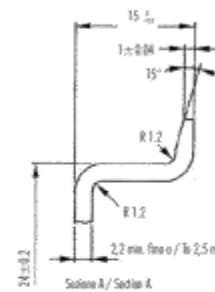

Sezione A / Section A



CARATTERISTICA	METODO	UNITA'	BIENNO DI MISURA	BIENNO PUNTI
Meccaniche	Resistenza a trazione (allungamento)	ASTM B638	MPa	48
	Resistenza a trazione (rotture)	ASTM B638	MPa	48
	Allungamento a rottura	ASTM B638	%	10
	Resistenza a flessione	ASTM B790	MPa	2804
	Pressione test con intaglio	ISO 18014	MPa	5.5
Termiche	Terna di accelerazione (Viel. retardo II)	ASTM E525	°C	114
	Temperatura fuso T.21 (M)	ASTM D440	°C	97
Fisiche	Forza spinta	ASTM E702	g/cm2	1.21
	Forza sulla colonna	ASTM E955	%	0.4/0.6
	Mod. 1 (con indici 200°C - 950)	ASTM E1228	g/cm2	11.7
	Comportamento Antidroppezze (forza di spinta)	DM	-	V-4 (0.8)
Velocità fiamma	ISO 15000-1, 22 min	ISO 9511	°C	960

Industria si riserva il diritto di modificare il materiale con cui realizza i propri prodotti senza obbligo di preavviso.

FEATURES	TEST METHOD	UNITS	BIENNO POINTS	
Mechanical test	Tensile strength (elongation)	ASTM B638	MPa	48
	Tensile strength (rupture)	ASTM B638	MPa	48
	Elongation at rupture	ASTM B638	%	10
	Bending resistance	ASTM B790	MPa	2804
	Notch test pressure	ISO 18014	MPa	5.5
Thermal test	Heat resistance (temperature method II)	ASTM E525	°C	114
	Melting temperature T.21 (M)	ASTM D440	°C	97
Physical test	Spindle pressure	ASTM E702	g/cm2	1.21
	Spindle strength	ASTM E955	%	0.4/0.6
	Mod. 1 (with indices 200°C - 950)	ASTM E1228	g/cm2	11.7
	Flame test	Self-ignition (Resistance to fire)	DM	-
Flame test	Flame spread (ISO 15000-1, 22 min)	ISO 9511	°C	960

Industria reserves the right to change the materials without being obliged to pre-notify.



INDUSTRIAL SHIELDS

About Industrial Shields:

Direction: Fàbrica del Pont, 1-11

Zip/Postal Code: 08272

City: Sant Fruitós de Bages (Barcelona)

Country: Spain

Telephone: (+34) 938 760 191 / (+34) 635 693 611

Mail: industrialshields@industrialshields.com