

# Q5Z Global Laser Measurement Sensor with IO-Link Instruction Manual



Original Instructions  
p/n: 226330 Rev. B  
June 23, 2023

© Banner Engineering Corp. All rights reserved.

# Contents

---

<b>Contents .....</b>	<b>2</b>
<b>Chapter 1 Product Description</b>	
1.1 Models .....	5
1.2 Overview.....	5
1.3 Class 2 Laser Description and Safety Information .....	6
1.4 Features .....	7
<b>Chapter 2 Configuration Description</b>	
2.1 TEACH Mode .....	9
2.2 Response Speed .....	9
2.3 Gain and Sensitivity .....	9
2.4 Delay Timer .....	10
2.5 Channel 1 Output .....	10
2.6 Channel 2 Output/Function .....	10
<b>Chapter 3 Installation</b>	
3.1 Sensor Orientation for the Triangulation Models .....	11
3.2 Mount the Device.....	12
3.3 Wiring Diagram .....	12
3.4 Cleaning and Maintenance .....	13
3.5 Connecting to RSD1.....	13
<b>Chapter 4 Remote Input</b>	
4.1 Reset to Factory Defaults Using the Remote Input .....	15
<b>Chapter 5 Channel 2 Output or Function</b>	
5.1 Light Operate/Dark Operate .....	17
5.2 Complementary Output .....	17
5.3 Set .....	17
5.4 Laser On/Laser Off .....	17
5.5 Sync Master/Slave.....	17
5.6 Pulse Frequency Modulation (PFM) Output.....	18
<b>Chapter 6 TEACH Procedures</b>	
6.1 Two-Point Static Background Suppression .....	19
6.2 Dynamic Background Suppression .....	20
6.3 One-Point Window (Foreground Suppression).....	21
6.4 One-Point Background Suppression .....	23
6.5 Dual (Intensity + Distance) .....	24
<b>Chapter 7 IO-Link Interface .....</b>	<b>25</b>
<b>Chapter 8 Specifications</b>	
8.1 Dimensions .....	29
8.2 Performance Curves .....	29
<b>Chapter 9 Additional Information</b>	
9.1 Dual (Intensity + Distance) Mode .....	31
9.2 Dual Mode Reference Surface Considerations .....	32
9.3 Dual Mode Considerations for Clear and Transparent Object Detection .....	32
<b>Chapter 10 Accessories</b>	
10.1 Cordsets .....	35
10.2 Brackets.....	35

10.3 Reference Targets ..... 37  
10.4 RSD1 Remote Display..... 37

**Chapter 11 Product Support and Maintenance**

11.1 Contact Us ..... 39  
11.2 Banner Engineering Corp Limited Warranty ..... 39  
11.3 Document Information ..... 39

Index..... 40

*Blank page*

Chapter Contents

1.1 Models ..... 5  
 1.2 Overview ..... 5  
 1.3 Class 2 Laser Description and Safety Information ..... 6  
 1.4 Features ..... 7

# Chapter 1 Product Description

*Laser sensor with dual outputs and IO-Link*

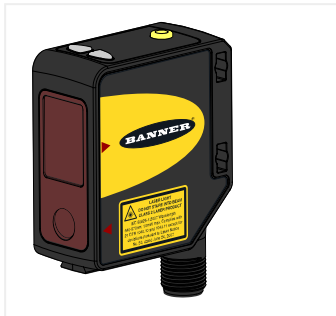

- Laser measurement sensor with a range up to 1800 mm
- Bright indicators provide feedback for output and configuration
- Exceptionally high excess gain enables the sensor to reliably detect the darkest objects (< 6% reflective black targets), including black targets against a black background, black targets against a shiny metal background, clear and reflective objects, multicolor packaging, and targets of all colors
- Dual independent output channels and communication over IO-Link
- Optional Remote Sensor Display (RSD) (available separately) enables remote programming and monitoring

**WARNING:**



- **Do not use this device for personnel protection**
- Using this device for personnel protection could result in serious injury or death.
- This device does not include the self-checking redundant circuitry necessary to allow its use in personnel safety applications. A device failure or malfunction can cause either an energized (on) or de-energized (off) output condition.

## 1.1 Models

Model	Sensing Range	Channel 1 Default	Channel 2 Default	Connection
Q5ZKLAF1800-Q8	95 mm to 1800 mm (0.31 ft to 5.9 ft)	IO-Link, Push/Pull	PNP	270° rotatable Integral 4-pin M12 male quick-disconnect connector

## 1.2 Overview

The Q5Z Global Laser Measurement Sensor is a Class 2 laser sensor with IO-Link and a multifunction output.

The single teach button and no display mean the sensor must be configured at the factory. This is so that it is ready for installation out of the box. To customize the configuration for an application, contact Banner Engineering.

## 1.3 Class 2 Laser Description and Safety Information

Read the following safety information for proper use of a Class 2 laser.

**CAUTION:**



- **Return defective units to the manufacturer.**
- Use of controls or adjustments or performance of procedures other than those specified herein may result in hazardous radiation exposure.
- Do not attempt to disassemble this sensor for repair. A defective unit must be returned to the manufacturer.

**CAUTION:**



- **Never stare directly into the sensor lens.**
- Laser light can damage your eyes.
- Avoid placing any mirror-like object in the beam. Never use a mirror as a retroreflective target.



**For Safe Laser Use - Class 2 Lasers**

- Do not stare at the laser.
- Do not point the laser at a person's eye.
- Mount open laser beam paths either above or below eye level, where practical.
- Terminate the beam emitted by the laser product at the end of its useful path.

Class 2 lasers are lasers that emit visible radiation in the wavelength range from 400 nm to 700 nm, where eye protection is normally afforded by aversion responses, including the blink reflex. This reaction may be expected to provide adequate protection under reasonably foreseeable conditions of operation, including the use of optical instruments for intrabeam viewing.

Low-power lasers are, by definition, incapable of causing eye injury within the duration of a blink (aversion response) of 0.25 seconds. They also must emit only visible wavelengths (400 to 700 nm). Therefore, an ocular hazard may exist only if individuals overcome their natural aversion to bright light and stare directly into the laser beam.

**Class 2 Red Laser models: Reference IEC 60825-1:2014**

*Figure 1. FDA (CDRH) warning label (Class 2)*



**Output:** < 1.0 mW

**Laser wavelength:** 640 to 670 nm

**Pulse Duration for <5 m Models:** 20  $\mu$ s to 2 ms

**Pulse Duration for  $\geq$  5 m Models:** 3  $\mu$ s

## 1.4 Features

The following shows the simplified user interface of the Q5Z Global.

Figure 2. Q5Z Global Features



1. Chanel 1 output indicator (amber)
2. Chanel 2 output indicator (amber)
3. Button

Use the sensor button (**TEACH**) to program the sensor. Press and hold for longer than 2 seconds to start the pre-configured TEACH mode.

Figure 3. Top View

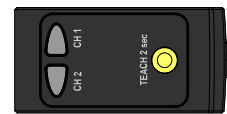

*Blank page*



Chapter Contents

2.1 TEACH Mode ..... 9  
 2.2 Response Speed ..... 9  
 2.3 Gain and Sensitivity ..... 9  
 2.4 Delay Timer ..... 10  
 2.5 Channel 1 Output ..... 10  
 2.6 Channel 2 Output/Function ..... 10

# Chapter 2 Configuration Description

The Q5Z Global sensor is pre-configured for ease of installation.

The following sections explain each setting. All of these settings can be adjusted from their factory default setting in the field using either an RSD or an IO-Link interface.

For assistance configuring the sensor, contact Banner Engineering.

## 2.1 TEACH Mode

The default Teach mode for Output 1 is pre-configured to one of the following options.

- Two-point static background suppression
- Dynamic background suppression
- One-point window (foreground suppression)
- One-point background suppression
- Dual (intensity + distance) window

See ["TEACH Procedures" on page 19](#) for additional information and remote input TEACH instructions.

**NOTE:** For one-point window (foreground suppression), the window is automatically determined during the teach process. If a specific window size is needed, contact Banner Engineering.

## 2.2 Response Speed

The response speed is pre-configured to one of the following options.

Use the following tables to choose a response speed that is appropriate for the application. Slowing down the response speed can assist in detecting dark targets.

Response Speed	Response Speed in Sync Mode	Repeatability	Ambient Light Rejection	Excess Gain
3 ms	6 ms	1000 µs	Disabled	See Excess Gain in <a href="#">"Specifications" on page 27</a>
5 ms	10 ms	1600 µs	Enabled	
15 ms	30 ms	3 ms	Enabled	
25 ms	50 ms	5 ms	Enabled	
50 ms	100 ms	10 ms	Enabled	

## 2.3 Gain and Sensitivity

The gain setting is pre-configured to one of the following options.

High excess gain is not available for 3- or 5-millisecond response speeds.

- High excess gain
- Standard excess gain mode with increased ambient light immunity

## 2.4 Delay Timer

The delay timer is pre-configured to one of the following options.

If a delay timer is needed, contact Banner Engineering.

- No Delay
- Delay timer(s) enabled
- 1-Shot enabled
- Totalizer enabled

## 2.5 Channel 1 Output

Output 1 is pre-configured to one of the following options.

- Light Operate (LO)
- Dark Operate (DO)

## 2.6 Channel 2 Output/Function

Output 2 is pre-configured to one of the following options.

- Light Operate (LO)
- Dark Operate (DO)
- Complementary output to CH1
- Remote TEACH input
- Laser inhibit input
- Laser enable input
- Master sync line output for two-sensor cross-talk avoidance
- Slave sync line output for two-sensor cross-talk avoidance
- Pulse Frequency Modulation (PFM) output (see ["Pulse Frequency Modulation \(PFM\) Output" on page 18](#))

For more details, see ["Channel 2 Output or Function " on page 17](#).

To configure the sensor for master-slave operation, see ["Sync Master/Slave" on page 17](#).

Chapter Contents

3.1 Sensor Orientation for the Triangulation Models ..... 11  
 3.2 Mount the Device ..... 12  
 3.3 Wiring Diagram ..... 12  
 3.4 Cleaning and Maintenance ..... 13  
 3.5 Connecting to RSD1 ..... 13

# Chapter 3 Installation

## 3.1 Sensor Orientation for the Triangulation Models

Optimize detection reliability and minimum object separation performance with correct sensor-to-target orientation.

To ensure reliable detection, orient the sensor as shown in relation to the target to be detected.

Figure 4. Optimal Orientation of Target to Sensor

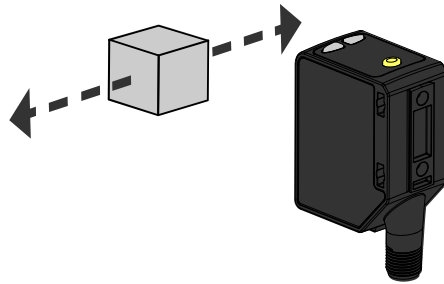

See the following figures for examples of correct and incorrect sensor-to-target orientation as certain placements may pose problems for sensing some targets. The Q5Z Global can be used in the less preferred orientation and at steep angles of incidence and still provide reliable detection performance due to its high excess gain. For the minimum object separation distance required for each case, refer to "Performance Curves " on page 29.

<p><i>Figure 5. Orientation by a wall</i></p> <p><b>Correct</b>      <b>Incorrect</b></p>	<p><i>Figure 6. Orientation for a moving object</i></p> <p><b>Correct</b>      <b>Incorrect</b></p>	<p><i>Figure 7. Orientation for a height difference</i></p> <p><b>Correct</b>      <b>Incorrect</b></p>
---	---	---

Continued on page 12

Continued from page 11

Figure 8. Orientation for a color or luster difference

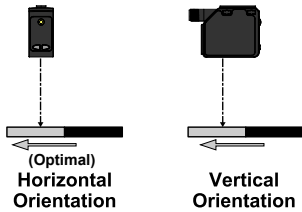
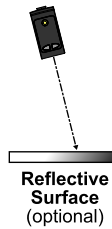

Figure 9. Orientation for highly reflective target<sup>(1)</sup>



## 3.2 Mount the Device

1. If a bracket is needed, mount the device onto the bracket.
2. Mount the device (or the device and the bracket) to the machine or equipment at the desired location. Do not tighten the mounting screws at this time.
3. Check the device alignment.
4. Tighten the mounting screws to secure the device (or the device and the bracket) in the aligned position.

## 3.3 Wiring Diagram

Figure 10. Channel 2 as PNP Discrete or PFM Output

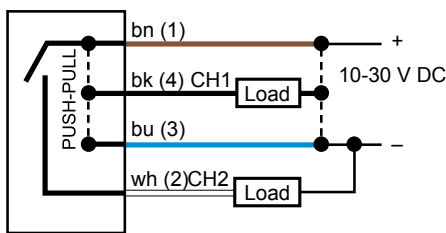
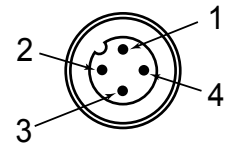
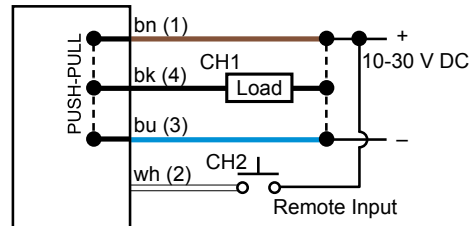
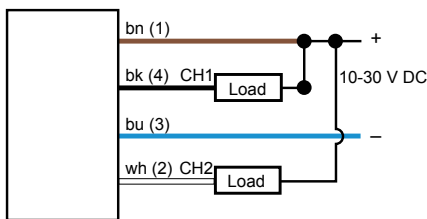

Figure 11. Channel 2 as Remote Input



### NPN Discrete Outputs

Figure 12. Channel 1 = NPN Output, Channel 2 = NPN Output



### PNP Discrete Outputs

Figure 13. Channel 1 = PNP Output, Channel 2 = PNP Output

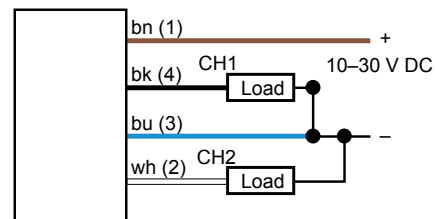

Continued on page 13

<sup>(1)</sup> Applying tilt to sensor may improve performance on reflective targets. The direction and magnitude of the tilt depends on the application, but a 15° tilt is often sufficient.

Continued from page 12

**NPN Output and Remote Input**

Figure 14. Channel 1 = NPN Output, Channel 2 = NPN Remote Input

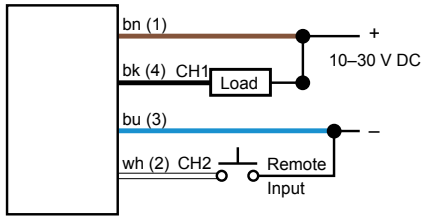

**PNP Output and Remote Input**

Figure 15. Channel 1 = PNP Output, Channel 2 = PNP Remote Input

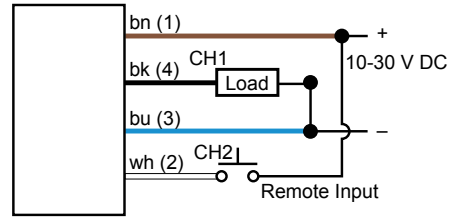

**NOTE:** Open lead wires must be connected to a terminal block.

**NOTE:** The Channel 2 wire function and polarity is defined by the model number. **Q5ZK...** and **Q5ZP...** models have a PNP output and **Q5ZN...** models have NPN.

### 3.4 Cleaning and Maintenance

Clean the sensor when soiled and use with care.

Handle the sensor with care during installation and operation. Sensor windows soiled by fingerprints, dust, water, oil, etc. may create stray light that may degrade the peak performance of the sensor. Blow the window clear using filtered, compressed air, then clean as necessary using only water and a lint-free cloth.

### 3.5 Connecting to RSD1

The following diagram depicts the connection of the Q5Z Global to the optional RSD1 accessory.

For more information on how to program the Q5Z Global with the RSD1, see the *Q5X Laser Measurement Sensor with IO-Link Instruction Manual*, p/n 208794.

Figure 16. Q5Z Global to RSD1

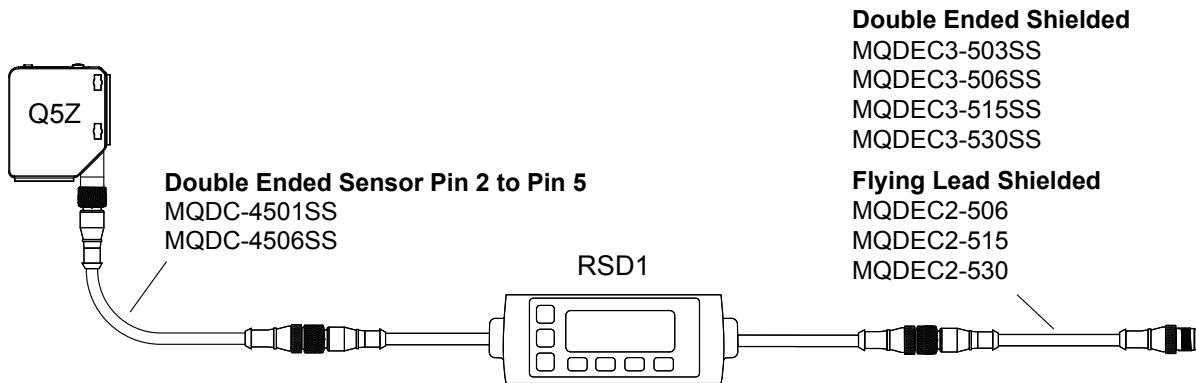

Use these cordsets to connect the RSD1 to the Q5Z Global sensor.

4-Pin Female and 5-Pin Male Threaded M12 Cordset—Double Ended				
Model	Length "L1"	Style	Pinout	
MQDC-4501SS	0.30 m (0.98 ft)	Female Straight/ Male Straight	Male	1 = Brown 2 = Not Used 3 = Blue 4 = Black 5 = White
MQDC-4506SS	1.83 m (6.00 ft)		Female	

Use these cordsets to connect the RSD1 to any PLC or IO block.

5-Pin Male Threaded and 5-Pin Female Quick Disconnect M12 Cordset with Shield—Double Ended				
Model	Length "L1"	Style	Pinout (Male)	Pinout (Female)
MQDEC3-503SS	0.91 m (2.99 ft)	Female Straight/Male Straight		
MQDEC3-506SS	1.83 m (6 ft)			
MQDEC3-515SS	4.58 m (15 ft)			
MQDEC3-530SS	9.2 m (30.2 ft)			
			1 = Brown 2 = White 3 = Blue	4 = Black 5 = Gray

5-Pin Threaded M12 Cordsets with Shield—Single Ended				
Model	Length	Style	Dimensions	Pinout (Female)
MQDEC2-506	2 m (6.56 ft)	Straight		
MQDEC2-515	5 m (16.4 ft)			
MQDEC2-530	9 m (29.5 ft)			
MQDEC2-550	15 m (49.2 ft)			
MQDEC2-575	23 m (75.44 ft)			
MQDEC2-5100	30.5 m (100 ft)	Right-Angle		1 = Brown 2 = White 3 = Blue 4 = Black 5 = Gray
MQDEC2-506RA	2 m (6.56 ft)			
MQDEC2-515RA	5 m (16.4 ft)			
MQDEC2-530RA	9 m (29.5 ft)			
MQDEC2-550RA	15 m (49.2 ft)			
MQDEC2-575RA	23 m (75.44 ft)			
MQDEC2-5100RA	31 m (101.68 ft)			

Chapter Contents

4.1 Reset to Factory Defaults Using the Remote Input ..... 15

# Chapter 4 Remote Input

Use the remote input to program the sensor remotely.

Remote input is available when the Channel 2 Function is configured to Remote TEACH input.

The remote input provides limited programming options and is configured to be Active High (PNP).

For Active High (PNP), connect the white wire to 24 V DC with a remote switch connected between the wire and 24 V DC.

Pulse the remote input according to the diagram and the instructions provided in this manual.

The length of the individual programming pulses is equal to the value **T: 0.04 seconds ≤ T ≤ 0.8 seconds**.

Exit remote programming modes by activating the remote input for longer than 2 seconds.

Figure 17. Remote Input Map

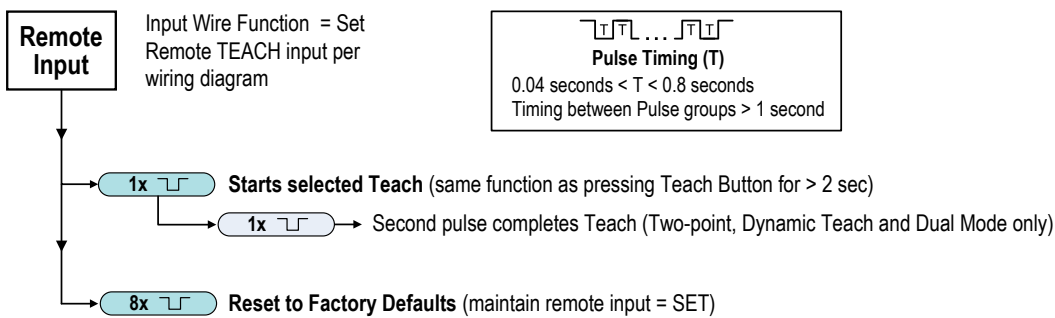

## 4.1 Reset to Factory Defaults Using the Remote Input

Follow the instructions below to reset the Q5Z Global to factory defaults using Remote Input.

Eight-pulse the remote input to apply the factory defaults and return to Run mode.



**NOTE:** The input wire function remains at remote teach input.

*Blank page*



## Chapter Contents

5.1 Light Operate/Dark Operate .....	17
5.2 Complementary Output .....	17
5.3 Set .....	17
5.4 Laser On/Laser Off .....	17
5.5 Sync Master/Slave .....	17
5.6 Pulse Frequency Modulation (PFM) Output .....	18

## Chapter 5 Channel 2 Output or Function

### 5.1 Light Operate/Dark Operate

The output of Channel 2 can be pre-configured to light operate or dark operate and is independent of Channel 1. The teach method of both channels is the same.

See "[TEACH Procedures](#)" on page 19 for instructions on teaching Channel 2.

In light operate, the output turns on when a target is present inside the switch points of the sensor.

In dark operate, the output turns off when a target is present inside the switch points of the sensor.

### 5.2 Complementary Output

Output 2 switches opposite of Output 1.

### 5.3 Set

Allows the Q5Z Global to use its remote input.

For more details, see "[Remote Input](#)" on page 15.

### 5.4 Laser On/Laser Off

The laser can be controlled to either turn on or off depending on the setting by activating the remote input wire.

For more details, see "[Remote Input](#)" on page 15.

### 5.5 Sync Master/Slave

A maximum of two Q5Z Global sensors may be used together in a single sensing application.

To eliminate crosstalk between the two sensors, configure one sensor to be the master and one to be the slave, then connect the white wires together. In this mode, the sensors alternate taking measurements and the response speed doubles.

**NOTE:** The master sensor and the slave sensor must be configured for the same Response Speed and Gain and Sensitivity settings. The master sensor and slave sensor must share a common power source.

## 5.6 Pulse Frequency Modulation (PFM) Output

The Q5Z Global can generate pulses whose frequency are proportional to the sensor's measured distance, thereby providing a method for representing an analog signal with only a discrete counter.

The sensing range of the sensor is scaled from 100 to 600 Hz (100 Hz equals the near range limit of the sensor, 600 Hz equals the far sensing range limit). An output of 50 Hz represents a Loss of Signal condition where there is no target or the target is out of the sensor's range.

Chapter Contents

6.1 Two-Point Static Background Suppression ..... 19  
 6.2 Dynamic Background Suppression ..... 20  
 6.3 One-Point Window (Foreground Suppression) ..... 21  
 6.4 One-Point Background Suppression ..... 23  
 6.5 Dual (Intensity + Distance) ..... 24

# Chapter 6 TEACH Procedures

Use the following procedures to teach the sensor.

Channel 2 can be taught only if the sensor has been configured for channel 2 to be light operate or dark operate. To change the active channel, press the **TEACH** five times. The LED indicator of the now-activated channel flashes five times and can be taught normally. The teach method of both channels is the same.

**NOTE:** If the TEACH procedure is in process, it can be canceled by pressing the **TEACH** button for longer than 2 seconds or by holding the remote input high for longer than 2 seconds.

## 6.1 Two-Point Static Background Suppression

Two-point TEACH sets a single switch point. The sensor sets the switch point between two taught target distances, relative to the shifted origin location.

Figure 18. Two-Point Static Background Suppression (Light Operate shown)

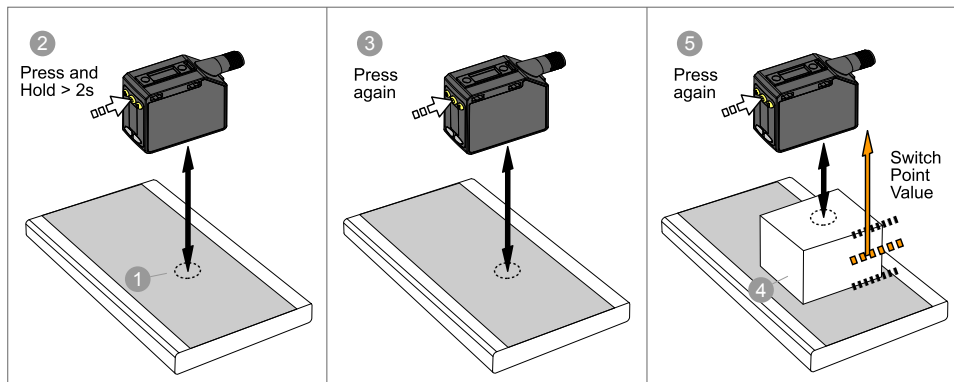

1. Present the target.

Method	Action	Result
Push Button	Present the first target. The sensor-to-target distance must be within the sensor's range.	
Remote Input		

2. Start the TEACH mode.

Method	Action	Result
Push Button	Press and hold <b>TEACH</b> for longer than 2 seconds.	The indicator of the active channel flashes.
Remote Input	No action required.	N/A

3. Teach the sensor.

Method	Action		Result
<b>Push Button</b>	Press <b>TEACH</b> to teach the target.		The sensor is taught the first target. The indicator of the active channel flashes in pairs.
<b>Remote Input</b>	Single-pulse the remote input.		

4. Present the target.

Method	Action		Result
<b>Push Button</b>	Present the second target. The sensor-to-target distance must be within the sensor's range.		
<b>Remote Input</b>			

5. Teach the sensor.

Method	Action		Result
<b>Push Button</b>	Press <b>TEACH</b> to teach the target.		The indicator of the active channel flashes three times and the sensor returns to run mode.
<b>Remote Input</b>	Single-pulse the remote input.		

See "Performance Curves " on page 29 for the minimum object separation.

Table 1. Expected TEACH Behavior for Two-Point Static Background Suppression

Condition	TEACH Result	Display
Two valid distances that are greater than or equal to the horizontal minimum object separation	Sets a switch point between the two taught distances.	The indicator of the active channel flashes three times.
Two valid distances that are less than the horizontal minimum object separation	Sets a switch point in front of the furthest taught distance equal to the uniform reflectivity minimum object separation.	The indicator of the active channel flashes six times.
One valid distance with one invalid TEACH point	Sets a switch point between the one taught distance and the maximum range.	The indicator of the active channel flashes eight times.
Two invalid TEACH points	Sets a switch point at 174 cm.	The indicator of the active channel flashes ten times.

## 6.2 Dynamic Background Suppression

Dynamic TEACH sets a single switch point during machine run conditions.

Dynamic TEACH is recommended for applications where a machine or process may not be stopped for teaching. The sensor takes multiple samples and the switch point is set between the minimum and the maximum sampled distances.

Figure 19. Dynamic Background Suppression

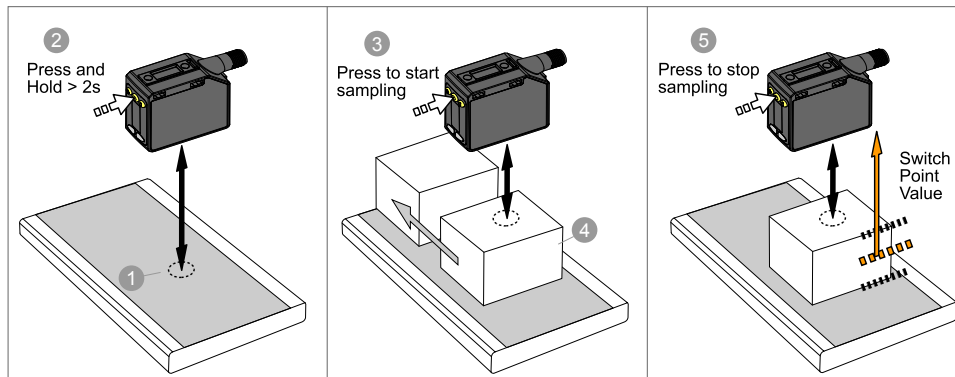

1. Present the target.

Method	Action	Result
Push Button	Present the first target. The sensor-to-target distance must be within the sensor's range.	
Remote Input		

2. Start the TEACH mode.

Method	Action	Result
Push Button	Press and hold <b>TEACH</b> for longer than 2 seconds.	The indicator of the active channel flashes.
Remote Input	No action required.	N/A

3. Teach the sensor.

Method	Action	Result
Push Button	Press <b>TEACH</b> to teach the target.	The sensor begins sampling target distance information. The indicator of the active channel flashes in pairs.
Remote Input	Single-pulse the remote input. 	

4. Present the targets.

Method	Action	Result
Push Button	Present additional targets. The sensor-to-target distance must be within the sensor's range.	The sensor continues to sample target distance information. The indicator of the active channel flashes in pairs.
Remote Input		

5. Teach the sensor.

Method	Action	Result
Push Button	Press <b>TEACH</b> to stop teaching the sensor.	The indicator of the active channel flashes three times and the sensor returns to run mode.
Remote Input	Single-pulse the remote input. 	

See "Performance Curves " on page 29 for the minimum object separation.

Table 2. Expected TEACH Behavior for Dynamic Background Suppression

Condition	TEACH Result	Display
Two valid distances that are greater than or equal to the horizontal minimum object separation	Sets a switch point between the two taught distances.	The indicator of the active channel flashes three times.
Two valid distances that are less than the horizontal minimum object separation	Sets a switch point in front of the furthest taught distance equal to the uniform reflectivity minimum object separation.	The indicator of the active channel flashes six times.
One valid distance with one invalid TEACH point	Sets a switch point between the one taught distance and the maximum range.	The indicator of the active channel flashes eight times.
Two invalid TEACH points	Sets a switch point at 120 cm.	The indicator of the active channel flashes ten times.

### 6.3 One-Point Window (Foreground Suppression)

One-point window sets a window (two switch points) centered around the taught target distance.

Loss of signal is treated as a detection in One-Point Window mode. The default size of the taught window is the vertical minimum object separation. See "Performance Curves " on page 29.

Figure 20. One-Point Window (Foreground Suppression)

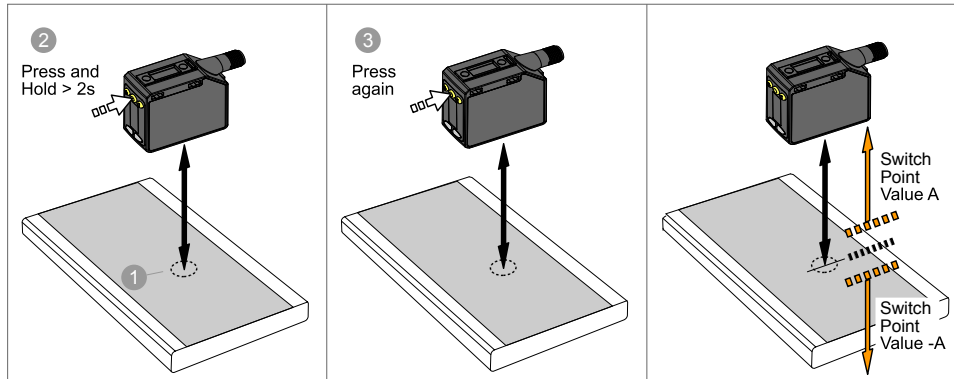

1. Present the target.

Method	Action	Result
Push Button	Present the target. The sensor-to-target distance must be within the sensor's range.	
Remote Input		

2. Start the TEACH mode.

Method	Action	Result
Push Button	Press and hold <b>TEACH</b> for longer than 2 seconds.	The indicator of the active channel flashes.
Remote Input	No action required.	N/A

3. Teach the sensor.

Method	Action	Result
Push Button	Press <b>TEACH</b> to teach the target.	
Remote Input	Single-pulse the remote input.	 The indicator of the active channel flashes three times and the sensor returns to Run mode.

See "Performance Curves " on page 29 for the minimum object separation.

Table 3. Expected TEACH Behavior for One-Point Window (Foreground Suppression)

Condition	TEACH Result	Display
One valid TEACH point with both switch points in range (with offset, if applicable)	Sets a window (two switch points) centered around the taught distance. The default $\pm$ window size is equal to the non-uniform reflectivity minimum object separation. The two switch points always stay within the specified sensing range.	The indicator of the active channel flashes three times.
One invalid TEACH Point	Sets a window (two switch points) centered around 150 cm. The window size is $\pm$ 10 cm.	The indicator of the active channel flashes six times.
One valid TEACH point with one switch point within range and one switch point out of range (with offset, if applicable)	Sets a window (two switch points) that is centered at the TEACH point (after offset, if applicable) with one switch point at the maximum range.	The indicator of the active channel flashes six times.
One valid TEACH point that, after the offset, results in a both switch points outside of the range	Sets a window (two switch points) centered around 150 cm. The window size is $\pm$ 10 cm.	The indicator of the active channel flashes six times.

## 6.4 One-Point Background Suppression

One-point background suppression sets a single switch point in front of the taught target distance. Objects beyond the taught switch point are ignored.

The switch point is set in front of the taught target distance by the vertical minimum object separation. See "[Performance Curves](#)" on page 29.

Figure 21. One-Point Background Suppression

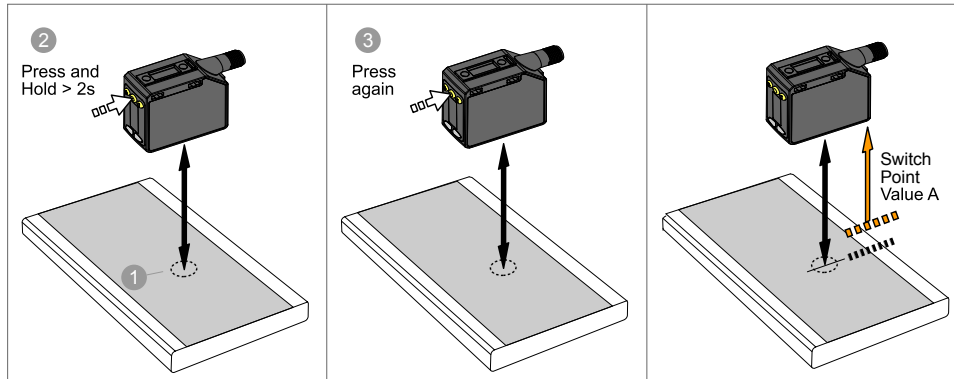

1. Present the target.

Method	Action	Result
<b>Push Button</b>	Present the target. The sensor-to-target distance must be within the sensor's range.	
<b>Remote Input</b>		

2. Start the TEACH mode.

Method	Action	Result
<b>Push Button</b>	Press and hold <b>TEACH</b> for longer than 2 seconds.	The indicator of the active channel flashes.
<b>Remote Input</b>	No action required.	N/A

3. Teach the sensor.

Method	Action	Result
<b>Push Button</b>	Press <b>TEACH</b> to teach the target.	The indicator of the active channel flashes three times and the sensor returns to Run mode.
<b>Remote Input</b>	Single-pulse the remote input.	

See "[Performance Curves](#)" on page 29 for the minimum object separation.

Table 4. Expected TEACH Behavior for One-Point Background Suppression

Condition	TEACH Result	Display
One valid TEACH point If an Offset is applied, the TEACH point is still valid	Sets a switch point in front of the taught distance equal to the non-uniform reflectivity minimum object separation.	The indicator of the active channel flashes three times.
One invalid TEACH point	Sets a switch point at 120 cm.	The indicator of the active channel flashes six times.
One valid TEACH point that, after offset, becomes invalid	Sets a switch point at 120 cm.	The indicator of the active channel flashes six times.

## 6.5 Dual (Intensity + Distance)

Dual (intensity + distance) TEACH records the distance and amount of light received from the reference surface.

The output switches when an object passing between the sensor and the reference surface changes the perceived distance or amount of returned light. For more information, see ["Additional Information" on page 31](#).

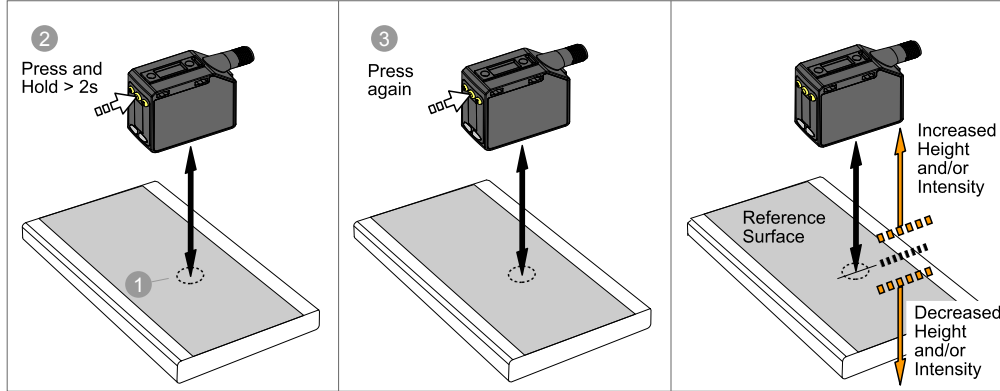

1. Present the target.

Method	Action	Result
Push Button Remote Input	Present the reference target.	

2. Start the TEACH mode.

Method	Action	Result
Push Button	Press and hold the TEACH button for more than 2 seconds.	The indicator of the active channel flashes.
Remote Input	No action required.	N/A

3. Teach the sensor.

Method	Action	Result
Push Button	Press the TEACH button.	
Remote Input	Single-pulse the remote input.	 The indicator of the active channel flashes three times and the sensor returns to run mode.

Table 5. Expected TEACH Behavior for Dual (Intensity + Distance) Mode

Condition	TEACH Result	Display
One valid reference surface is taught within sensing range	Sets a dual (intensity + distance) window centered around the taught reference surface. The $\pm$ window size is the previously used switching threshold, or 50% by default.	The indicator of the active channel flashes three times.
One reference surface is taught outside the sensing range	Sets a dual (intensity + distance) window centered around the taught reference surface that is outside the sensing range. The sensing conditions may not be as reliable.	The indicator of the active channel flashes three times.
One invalid TEACH Point	No reference surface is taught, the output will change when any object is detected.	The indicator of the active channel flashes six times.



## Chapter 7 IO-Link Interface

---

IO-Link is a point-to-point communication link between a master device and sensor. Use IO-Link to parameterize sensors and transmit process data automatically.

For the latest IO-Link protocol and specifications, see [www.io-link.com](http://www.io-link.com).

Each IO-Link device has an IODD (IO Device Description) file that contains information about the manufacturer, article number, functionality etc. This information can be easily read and processed by the user. Each device can be unambiguously identified via the IODD as well as via an internal device ID. Download the Q5Z Global's IO-Link IODD package (p/n 206833) from Banner Engineering's website at [www.bannerengineering.com](http://www.bannerengineering.com).

Banner has also developed Add On Instruction (AOI) files to simplify ease-of-use between the Q5Z Global, multiple third-party vendors' IO-Link masters, and the Logix Designer software package for Rockwell Automation PLCs. Three types of AOI files for Rockwell Allen-Bradley PLCs are listed below. These files and more information can be found at [www.bannerengineering.com](http://www.bannerengineering.com).

**Process Data AOIs**—These files can be used alone, without the need for any other IO-Link AOIs. The job of a Process Data AOI is to intelligently parse out the Process Data word(s) in separate pieces of information. All that is required to make use of this AOI is an EtherNet/IP connection to the IO-Link Master and knowledge of where the Process Data registers are located for each port.

**Parameter Data AOIs**—These files require the use of an associated IO-Link Master AOI. The job of a Parameter Data AOI, when working in conjunction with the IO-Link Master AOI, is to provide quasi-realtime read/write access to all IO-Link parameter data in the sensor. Each Parameter Data AOI is specific to a given sensor or device.

**IO-Link Master AOIs**—These files require the use of one or more associated Parameter Data AOIs. The job of an IO-Link Master AOI is to translate the desired IO-Link read/write requests, made by the Parameter Data AOI, into the format a specific IO-Link Master requires. Each IO-Link Master AOI is customized for a given brand of IO-Link Master.

Add and configure the relevant Banner IO-Link Master AOI in your ladder logic program first; then add and configure Banner IO-Link Device AOIs as desired, linking them to the Master AOI as shown in the relevant AOI documentation.

*Blank page*

Chapter Contents

8.1 Dimensions ..... 29  
 8.2 Performance Curves ..... 29

# Chapter 8 Specifications

**Sensing Beam**

Visible red Class 2 laser models, 650 nm

**Supply Voltage (Vcc)**

10 to 30 V DC (Class 2 supply) (10% max ripple within limits)

**Supply Protection Circuitry**

Protected against reverse polarity and transient overvoltages

**Power and Current Consumption, exclusive of load**

< 1 W

**Sensing Range**

95 mm to 1800 mm (3.74 in to 70.86 in)

**Output Configuration**

Channel 1: IO-Link, Push/pull output, configurable PNP or NPN output

Channel 2: Multi-function remote input/output, configurable PNP or NPN, or pulse frequency modulated output

**Temperature Effect (Typical)**

< 0.5 mm/°C at < 500 mm

< 1.0 mm/°C at < 1000 mm

< 3.5 mm/°C at < 1800 mm

**Remote Input**

Allowable Input Voltage Range: 0 to Vsupply

Active High (internal weak pull-down): High state > (Vsupply – 2.25 V) at 2 mA maximum

Active Low (internal weak pull-up): Low state < 2.25 V at 2 mA maximum

**IO-Link Interface**

IO Link Revision V1.1

Smart Sensor Profile: Yes

Baud Rate: 38400 bps

Process Data In Length: 32 bits

Process Data Out Length: 8 bits

Minimum Cycle Time: 3.6 ms

IODD files: Provides all programming options of the display, plus additional functionality.

**Boresighting**

± 43 mm at 1800 mm

**Response Speed**

User selectable 3, 5, 15, 25, or 50 ms

**Delay at Power Up**

< 2.5 s

**Maximum Torque**

Side mounting: 1 N·m (9 in·lbs)

**Ambient Light Immunity**

2000 lux at 1.8 m

**Connector**

Integral 4-pin M12 male quick-disconnect connector

**Construction**

Housing: ABS

Lens cover: PMMA acrylic

Lightpipe: polycarbonate

**Application Note**

For optimum performance, allow 10 minutes for the sensor to warm up

**Environmental Rating**

IP67 per IEC60529

**Vibration**

MIL-STD-202G, Method 201A (Vibration: 10 Hz to 55 Hz, 0.06 inch (1.52 mm) double amplitude, 2 hours each along X, Y and Z axes), with device operating

**Shock**

MIL-STD-202G, Method 213B, Condition I (100G 6x along X, Y, and Z axes, 18 shocks), with device operating

**Operating Conditions**

–10 °C to +50 °C (+14 °F to +122 °F)

35% to 95% relative humidity

**Storage Temperature**

–25 °C to +70 °C (–13 °F to +158 °F)

**Output Rating**

Current rating: 50 mA maximum

Black wire specifications per configuration		
IO-Link Push/Pull	Output High:	≥ Vsupply - 2.5 V
	Output Low:	≤ 2.5 V
PNP	Output High:	≥ Vsupply - 2.5 V
	Output Low:	≤ 1V (loads ≤ 1 MegΩ)
NPN	Output High:	≥ Vsupply - 2.5 V (loads ≤ 50 kΩ)
	Output Low:	≤ 2.5 V

White wire specifications per configuration		
PNP	Output High:	≥ Vsupply - 2.5 V
	Output Low:	≤ 2.5 V (loads ≤ 70 kΩ)
NPN	Output High:	≥ Vsupply - 2.5 V (loads ≤ 70 kΩ)
	Output Low:	≤ 2.5 V

**Beam Spot Size**

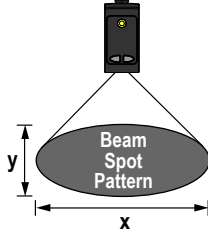

Distance (mm)	Size (x × y) (mm)
100	3.8 × 5.0
1000	5.2 × 6.5
1800	7.0 × 6.2

Beam spot size is calculated as 1.6 times the D4σ measured value

**Discrete Output Distance Repeatability**

Distance (mm)	Repeatability (1800 mm Models)
95 to 300	± 0.5 mm
300 to 1000	± 0.25%
1000 to 1800	± 0.52%

**Required Overcurrent Protection**



**WARNING:** Electrical connections must be made by qualified personnel in accordance with local and national electrical codes and regulations.

Overcurrent protection is required to be provided by end product application per the supplied table.

Overcurrent protection may be provided with external fusing or via Current Limiting, Class 2 Power Supply.

Supply wiring leads < 24 AWG shall not be spliced.

For additional product support, go to [www.bannerengineering.com](http://www.bannerengineering.com).

Supply Wiring (AWG)	Required Overcurrent Protection (A)	Supply Wiring (AWG)	Required Overcurrent Protection (A)
20	5.0	26	1.0
22	3.0	28	0.8
24	1.0	30	0.5

**Typical Excess Gain**

Response Speed (ms)	High Excess Gain (Standard Excess Gain) Using a 90% White Card <sup>(1)</sup>			
	at 100 mm	at 500 mm	at 1000 mm	at 1800 mm
3	100	40	12	3
5	100	40	12	3
15	460 (140)	220 (65)	55 (20)	10 (5)
25	800 (520)	400 (220)	100 (55)	25 (12)
50	1600 (800)	800 (400)	200 (100)	50 (25)

**Certifications**



Banner Engineering BV  
Park Lane, Culliganlaan 2F bus 3  
1831 Diegem, BELGIUM



Turck Banner LTD Blenheim House  
Blenheim Court  
Wickford, Essex SS11 8YT  
GREAT BRITAIN



Industrial Control Equipment  
3TJJ

Class 2 power; UL Environmental Rating: Type 1

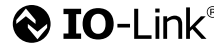

**Advanced Capabilities**



<sup>(1)</sup> Standard excess gain is available in 15, 25, and 50 ms response speeds; standard excess gain provides increased noise immunity.

## 8.1 Dimensions

All measurements are listed in millimeters [inches], unless noted otherwise.

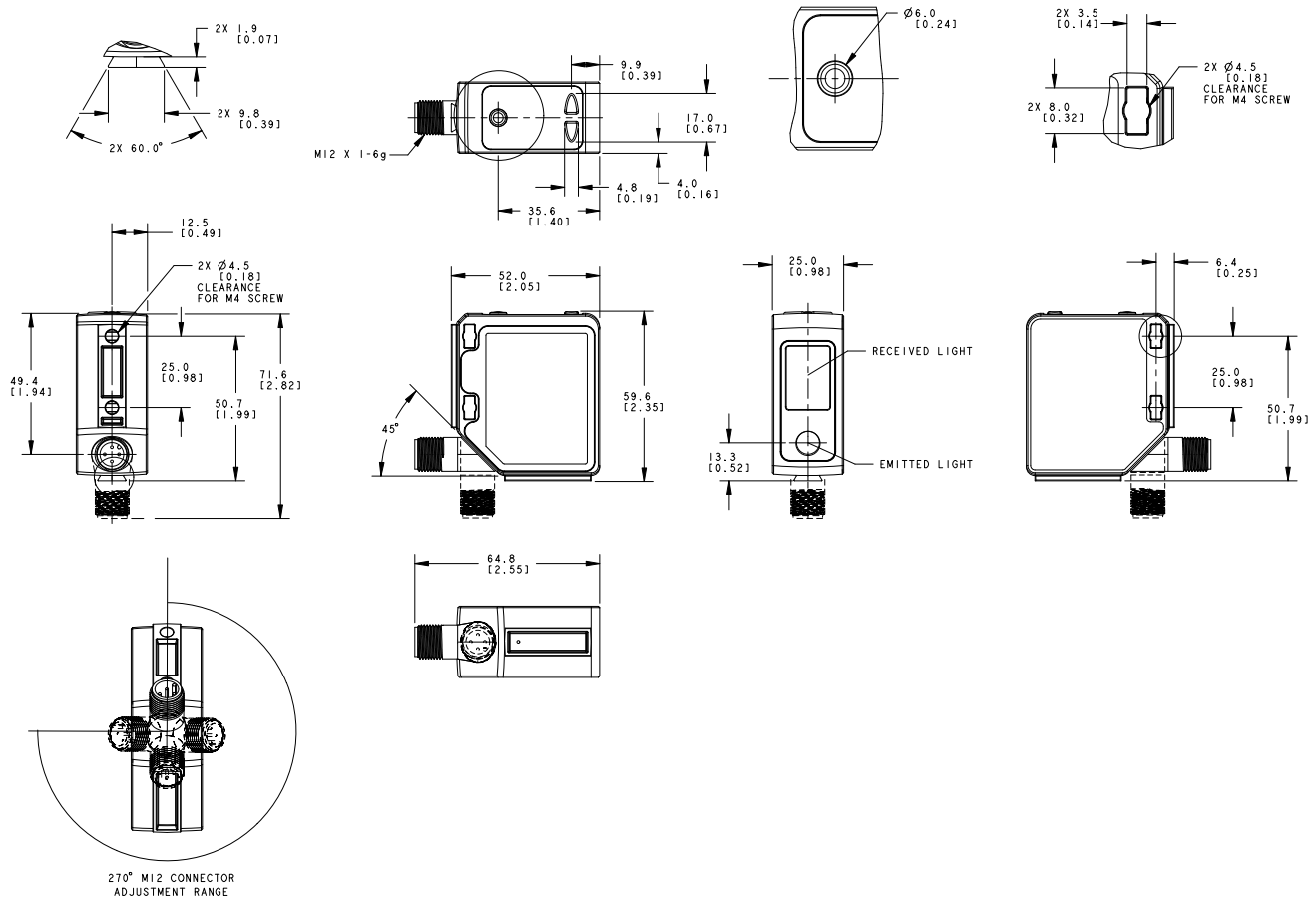

## 8.2 Performance Curves

Typical data for the sensor is shown.

Figure 22. Minimum Object Separation Distance (90% to 6% reflectance)

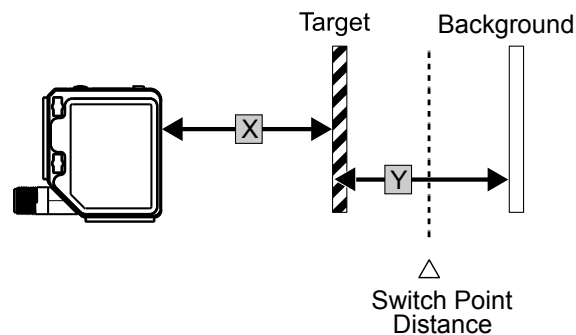
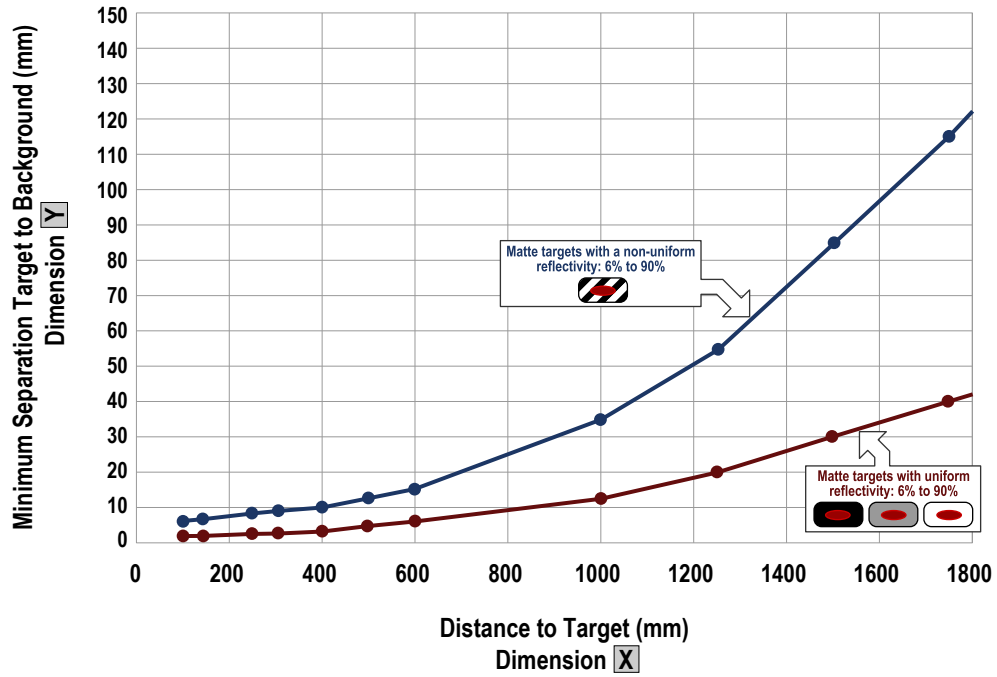

Figure 23. Minimum Object Separation (MOS) Specifications



Chapter Contents

9.1 Dual (Intensity + Distance) Mode ..... 31  
 9.2 Dual Mode Reference Surface Considerations ..... 32  
 9.3 Dual Mode Considerations for Clear and Transparent Object Detection ..... 32

# Chapter 9 Additional Information

## 9.1 Dual (Intensity + Distance) Mode

Dual TEACH mode, dual intensity + distance window, expands the applications the Q5Z Global can solve by combining distance-based detection with light intensity thresholds.

In background suppression (DYN, 1-pt, 2-pt) and foreground suppression (FGS) TEACH modes, the Q5Z Global sensor compares changes in the measured distance between the sensor and target to control the output state. In dual TEACH mode, the user teaches the Q5Z Global a fixed reference surface, and the sensor compares intensity and distance readings against the reference surface it was taught. After teaching the reference target, the displayed value is calibrated to 100P, or a 100% match. When an object enters the sensor’s field of view, the degree of consistency with the reference surface becomes lower and causes a change in sensor output.

In dual mode, you can detect when the target is present at the right distance and when it returns the right amount of light. This is useful in error-proofing applications where you need to know not only that the part is present (distance), but also that it is the correct part (intensity).

In dual mode, the Q5Z Global requires a reference surface (far left). Once taught, the distance and intensity of the reference surface are recorded and used as a baseline. A user-adjustable switching threshold is set, and changes in distance and/or intensity outside the switching threshold creates a sensor output change. The example uses a 90% (90P) match condition with a 10% change in intensity and/or distance from the reference surface required to change the output state. The default-switching threshold is a 50% match to the reference condition (50P); this sets the threshold 50% from the distance and intensity of the reference surface. A transparent object can be detected either by a change in intensity, distance, or by a double peak reflection (far right).

Figure 24. Dual Mode Example

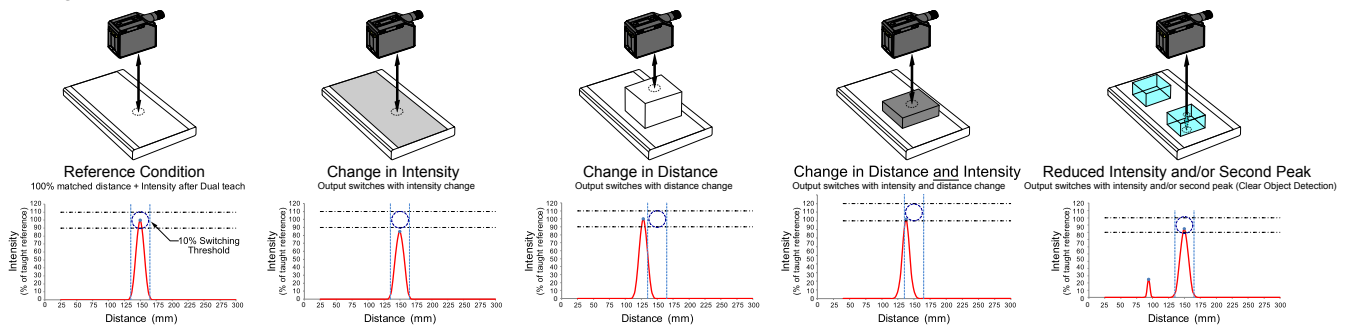

The Q5Z Global sensor can be taught non-ideal reference surfaces, such as surfaces outside of the sensor’s range, very dark surfaces, or even empty space. These situations may enable applications requiring a long range detection but are subject to typical diffuse mode detection challenges.

## 9.2 Dual Mode Reference Surface Considerations

Optimize reliable detection by applying these principles when selecting your reference surface, positioning your sensor relative to the reference surface, and presenting your target.

The robust detection capabilities of the Q5Z Global allows successful detection even under non-ideal conditions in many cases. Typical reference surfaces are metal machine frames, conveyor side rails, or mounted plastic targets. Contact Banner Engineering if you require assistance setting up a stable reference surface in your application.

1. Select a reference surface with these characteristics where possible:
  - Matte or diffuse surface finish
  - Fixed surface with no vibration
  - Dry surface with no build-up of oil, water, or dust
2. Position the reference surface between 200 mm (20 cm) and the maximum sensing range.
3. Position the target to be detected as close to the sensor as possible, and as far away from the reference surface as possible.
4. Angle the sensing beam relative to the target and relative to the reference surface 10 degrees or more.

## 9.3 Dual Mode Considerations for Clear and Transparent Object Detection

The Q5Z Global is able to detect the very small changes caused by transparent and clear objects. A transparent object can be detected either by a change in intensity, distance, or by a double-peak reflection.

The Q5Z Global sensor can be taught non-ideal reference surfaces, such as surfaces outside of the sensor range or very dark surfaces. Teaching non-ideal reference surfaces may enable applications other than transparent or clear object detection, but best results for transparent or clear object detection require a stable reference surface.

The display shows the match percentage to the taught reference point. The user adjustable switch point defines the sensitivity and the output switches when the match percentage to the reference point crosses the switch point. Your specific application may require fine tuning of the switch point, but these values are the recommended starting values:

Table 6. Match percentage to taught reference point

Switch point (%)	Typical Applications
50 (default)	Default, recommended for PET bottles and Trays
88	Recommended for thin films
50	Recommended for tinted brown, tinted green, or water-filled containers

Figure 25. Example mounting considerations

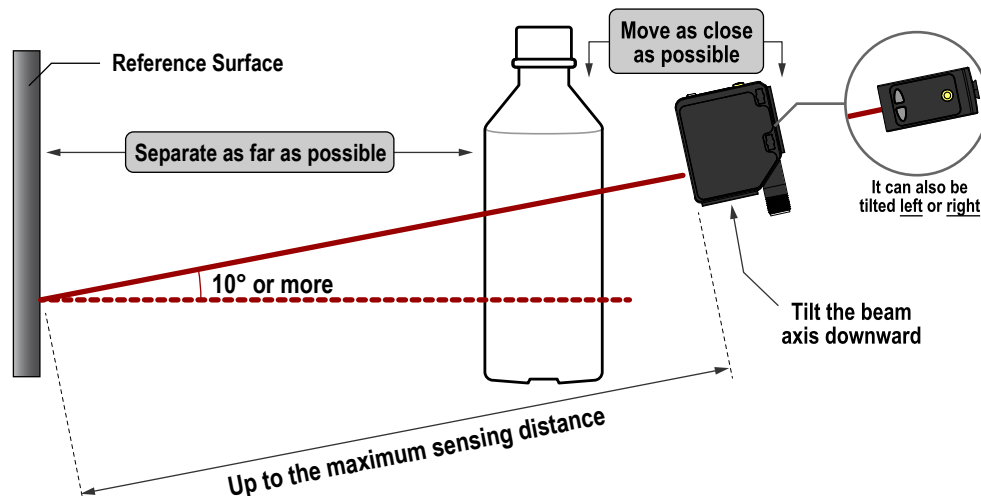
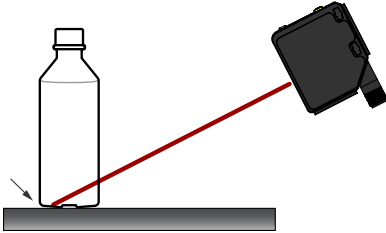



Figure 26. Common problems and solutions for detecting clear objects—Object too close

**PROBLEM:**

The object is close to the reference surface



**SOLUTION:**

Move the target closer to the sensor

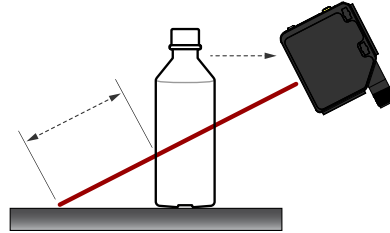
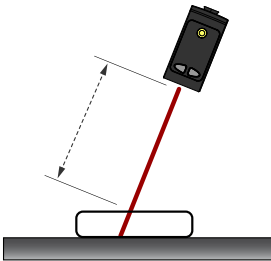

Figure 27. Common problems and solutions for detecting clear objects—Sensor too far

**PROBLEM:**

The sensor is far from the object



**SOLUTION:**

Move the sensor closer to the target

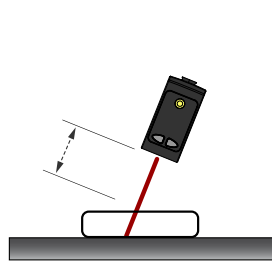

*Blank page*

Chapter Contents

10.1 Cordsets ..... 35  
 10.2 Brackets ..... 35  
 10.3 Reference Targets ..... 37  
 10.4 RSD1 Remote Display ..... 37

# Chapter 10 Accessories

## 10.1 Cordsets

4-Pin Threaded M12 Cordsets—Single Ended				
Model	Length	Style	Dimensions	Pinout (Female)
MQDC-406	2 m (6.56 ft)	Straight		
MQDC-415	5 m (16.4 ft)			
MQDC-430	9 m (29.5 ft)			
MQDC-450	15 m (49.2 ft)	Right-Angle		
MQDC-406RA	2 m (6.56 ft)			
MQDC-415RA	5 m (16.4 ft)			
MQDC-430RA	9 m (29.5 ft)			
MQDC-450RA	15 m (49.2 ft)	Right-Angle		
MQDC-406RA	2 m (6.56 ft)			
MQDC-415RA	5 m (16.4 ft)			
MQDC-430RA	9 m (29.5 ft)			
MQDC-450RA	15 m (49.2 ft)	Right-Angle		
MQDC-406RA	2 m (6.56 ft)			
MQDC-415RA	5 m (16.4 ft)			
MQDC-430RA	9 m (29.5 ft)			

1 = Brown  
 2 = White  
 3 = Blue  
 4 = Black  
 5 = Unused

## 10.2 Brackets

All measurements are listed in millimeters, unless noted otherwise.

**SMBQ5X..**

- Swivel bracket with tilt and pan movement for precision adjustment
- Easy sensor mounting to extruded rail T-slots
- Metric and inch size bolts are available
- Side mounting of some sensors with the 3 mm screws included with the sensor

Continued on page 36

Continued from page 35

**B = 7 × M3 × 0.5**

Bolt thread (A): 3/8 - 16 × 2¼ in for SMBQ5XFA; M10 - 1.5 × 50 for SMBQ5XFAM10; n/a; no bolt included. Mounts directly to 12 mm (½ in) rods for SMBQ5XFAM12

**SMBAMSQ5XIPRA**

- Enclosed bracket
- 13-ga. Stainless steel with borosilicate glass window
- Right angle mount plate

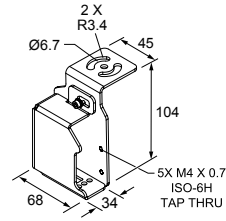

**SMBAMSQ5XIPP**

- Enclosed bracket
- 13-ga stainless steel with a borosilicate glass window
- Flat mount plate

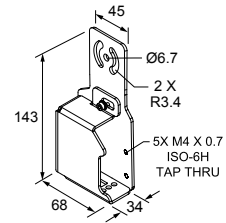

**SMBQ5XDT**

- Clamp bracket mounts to sensor dovetail
- Translation adjustment for sensor alignment
- Aluminum clamp - 6.5mm maximum plate thickness

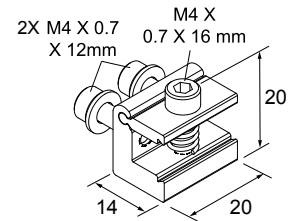

**SMBAMSQ5XP**

- Flat SMBAMS series bracket
- Articulation slots for 30 deg rotation
- 13-ga. 304 stainless steel

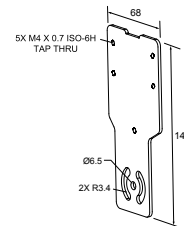

**SMBAMSQ5XRA**

- Right-angle SMBAMS series bracket
- Articulation slots for 30 deg rotation
- 13-ga. 304 stainless steel

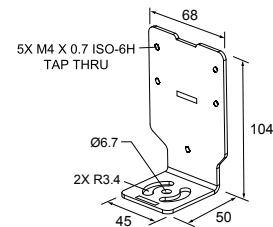

**SMBQ5XM4F**

- Fixing plates for mounting to back of sensor
- Stainless steel plates
- Customer supplied mounting plate thickness minimum 2 mm maximum 4 mm with screws included in kit

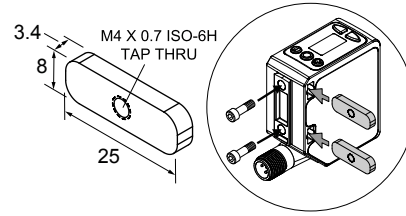

## 10.3 Reference Targets

All measurements are listed in millimeters, unless noted otherwise.

**BRT-Q4X-60X18**

- Reference target for clear object detection or dual-mode applications
- FDA grade acetal material

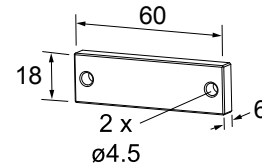

**BRT-Q4X-60X50**

- Reference target for clear object detection or dual-mode applications
- FDA grade acetal material

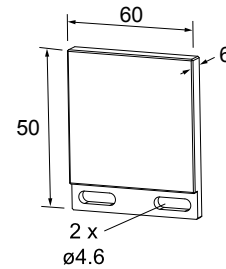

## 10.4 RSD1 Remote Display

Use the optional RSD1 for remote monitoring and configuring compatible devices.

Refer to the RSD1 instruction manual (p/n 199621) or quick start guide (p/n 199622) for more information. See "Accessories" on page 35 for the required cordsets.

RSD1 Remote Display				
Model	Output A and B	Dimensions	Male	Wiring
RSD1QP	Configurable			<ol style="list-style-type: none"> <li>1. Brown</li> <li>2. White</li> <li>3. Blue</li> <li>4. Black</li> <li>5. Gray</li> </ol>

*Blank page*

Chapter Contents

11.1 Contact Us ..... 39  
11.2 Banner Engineering Corp Limited Warranty ..... 39  
11.3 Document Information ..... 39

# Chapter 11 Product Support and Maintenance

## 11.1 Contact Us

Banner Engineering Corp. headquarters is located at: 9714 Tenth Avenue North | Minneapolis, MN 55441, USA | Phone: + 1 888 373 6767

For worldwide locations and local representatives, visit [www.bannerengineering.com](http://www.bannerengineering.com).

## 11.2 Banner Engineering Corp Limited Warranty

Banner Engineering Corp. warrants its products to be free from defects in material and workmanship for one year following the date of shipment. Banner Engineering Corp. will repair or replace, free of charge, any product of its manufacture which, at the time it is returned to the factory, is found to have been defective during the warranty period. This warranty does not cover damage or liability for misuse, abuse, or the improper application or installation of the Banner product.

**THIS LIMITED WARRANTY IS EXCLUSIVE AND IN LIEU OF ALL OTHER WARRANTIES WHETHER EXPRESS OR IMPLIED (INCLUDING, WITHOUT LIMITATION, ANY WARRANTY OF MERCHANTABILITY OR FITNESS FOR A PARTICULAR PURPOSE), AND WHETHER ARISING UNDER COURSE OF PERFORMANCE, COURSE OF DEALING OR TRADE USAGE.**

This Warranty is exclusive and limited to repair or, at the discretion of Banner Engineering Corp., replacement. **IN NO EVENT SHALL BANNER ENGINEERING CORP. BE LIABLE TO BUYER OR ANY OTHER PERSON OR ENTITY FOR ANY EXTRA COSTS, EXPENSES, LOSSES, LOSS OF PROFITS, OR ANY INCIDENTAL, CONSEQUENTIAL OR SPECIAL DAMAGES RESULTING FROM ANY PRODUCT DEFECT OR FROM THE USE OR INABILITY TO USE THE PRODUCT, WHETHER ARISING IN CONTRACT OR WARRANTY, STATUTE, TORT, STRICT LIABILITY, NEGLIGENCE, OR OTHERWISE.**

Banner Engineering Corp. reserves the right to change, modify or improve the design of the product without assuming any obligations or liabilities relating to any product previously manufactured by Banner Engineering Corp. Any misuse, abuse, or improper application or installation of this product or use of the product for personal protection applications when the product is identified as not intended for such purposes will void the product warranty. Any modifications to this product without prior express approval by Banner Engineering Corp will void the product warranties. All specifications published in this document are subject to change; Banner reserves the right to modify product specifications or update documentation at any time. Specifications and product information in English supersede that which is provided in any other language. For the most recent version of any documentation, refer to: [www.bannerengineering.com](http://www.bannerengineering.com).

For patent information, see [www.bannerengineering.com/patents](http://www.bannerengineering.com/patents).

## 11.3 Document Information

Document title: Q5Z Global Laser Measurement Sensor with IO-Link Instruction Manual  
Part number: 226330  
Revision: B  
Original Instructions. © Banner Engineering Corp. All rights reserved.

# Index

---

## B

buttons [7](#)

## C

clear object [32](#)

## D

dual mode [32](#), [32](#)

dual (intensity + distance) [31](#), [24](#)

dimensions [29](#)

default settings [15](#)

dynamic background suppression [20](#)

## F

factory default [15](#)

## I

IO-Link [25](#)

## L

laser safety [6](#)

## M

master [17](#)

minimum object separation [11](#)

## O

orientation [11](#)

one-point background suppression [23](#)

one-point window (foreground suppression) [21](#)

## P

pulse [18](#), [15](#)

## R

remote input [15](#)

## S

sync [17](#)

slave [17](#)

switch point [20](#)

switch point

two-point static background suppression [19](#)

## T

transparent object [32](#)



 [LinkedIn](#)

 [Twitter](#)

 [Facebook](#)

