

## LM3411 Precision Secondary Regulator/Driver

 Check for Samples: [LM3411](#)

### FEATURES

- Fixed Voltages of 3.3V and 5.0V with Initial Tolerance of  $\pm 1\%$  for Standard Grade and  $\pm 0.5\%$  for A Grade
- Custom Voltages Available (3V–17V)
- Wide Output Current Range, 20  $\mu\text{A}$ –15 mA
- Low Temperature Coefficient
- Available in 5-Lead SOT23-5 Surface Mount Package (Tape and Reel)

### APPLICATIONS

- Secondary Controller for Isolated DC/DC PWM Switching Regulators Systems
- Use with LDO Regulator for High-Precision Fixed Output Regulators
- Precision Monitoring Applications
- Use with many Types of Regulators to Increase Precision and Improve Performance

### DESCRIPTION

The LM3411 is a low power fixed-voltage (3.3V or 5.0V) precision shunt regulator designed specifically for driving an optoisolator to provide feedback isolation in a switching regulator.

The LM3411 circuitry includes an internally compensated op amp, a bandgap reference, NPN output transistor, and voltage setting resistors.

A trimmed precision bandgap reference with temperature drift curvature correction, provides an ensured 1% precision over the operating temperature range (A grade version). The amplifier's inverting input is externally accessible for loop frequency compensation when used as part of a larger servo system. The output is an open-emitter NPN transistor capable of driving up to 15 mA of load current.

Because of its small die size, the LM3411 has been made available in the sub-miniature 5-lead SOT23-5 surface mount package. This package is ideal for use in space critical applications.

Although its main application is to provide a precision output voltage (no trimming required) and maintain very good regulation in isolated DC/DC converters, it can also be used with other types of voltage regulators or power semiconductors to provide a precision output voltage without precision resistors or trimming.

### Typical Application and Functional Diagram

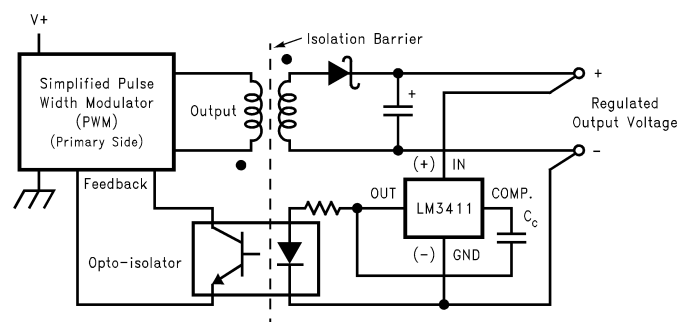

Figure 1. Basic Isolated DC/DC Converter



Please be aware that an important notice concerning availability, standard warranty, and use in critical applications of Texas Instruments semiconductor products and disclaimers thereto appears at the end of this data sheet.

All trademarks are the property of their respective owners.

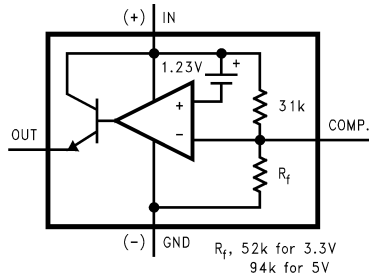
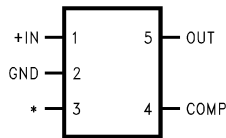

Figure 2. LM3411 Functional Diagram

Connection Diagrams



\*No internal connection, but should be soldered to PC board for best heat transfer.

Figure 3. 5-Lead SOT23-5 (DBV) Small Outline Package (M5)  
Package Number DBV0005A  
Top View

Figure 4. Actual Size



These devices have limited built-in ESD protection. The leads should be shorted together or the device placed in conductive foam during storage or handling to prevent electrostatic damage to the MOS gates.

### Absolute Maximum Ratings <sup>(1)(2)</sup>

Input Voltage V(IN)	20V
Output Current	20 mA
Junction Temperature	150°C
Storage Temperature	-65°C to +150°C
Lead Temperature	
Vapor Phase (60 sec.)	+215°C
Infrared (15 sec.)	+220°C
Power Dissipation (T <sub>A</sub> = 25°C) <sup>(3)</sup>	300 mW
ESD Susceptibility <sup>(4)</sup>	
Human Body Model	1500V

- (1) Absolute Maximum Ratings indicate limits beyond which damage to the device may occur. Operating Ratings indicate conditions for which the device is intended to be functional, but do not ensure specific performance limits. For ensured specifications and test conditions, see the Electrical Characteristics. The ensured specifications apply only for the test conditions listed. Some performance characteristics may degrade when the device is not operated under the listed test conditions.
- (2) If Military/Aerospace specified devices are required, please contact the Texas Instruments Sales Office/ Distributors for availability and specifications.
- (3) The maximum power dissipation must be derated at elevated temperatures and is dictated by T<sub>Jmax</sub> (maximum junction temperature), θ<sub>JA</sub> (junction to ambient thermal resistance), and T<sub>A</sub> (ambient temperature). The maximum allowable power dissipation at any temperature is (P<sub>Dmax</sub> = T<sub>Jmax</sub> - T<sub>A</sub>)/θ<sub>JA</sub> or the number given in the Absolute Maximum Ratings, whichever is lower. The typical thermal resistance (θ<sub>JA</sub>) when soldered to a printed circuit board is approximately 306°C/W for the DBV package.
- (4) The human body model is a 100 pF capacitor discharged through a 1.5 kΩ resistor into each pin.

See AN-450 [SNOA742](#) "Surface Mounting Methods and Their Effect on Product Reliability" for methods on soldering surface-mount devices.

### Operating Ratings <sup>(1)(2)</sup>

Ambient Temperature Range	-40°C ≤ T <sub>A</sub> ≤ +85°C
Junction Temperature Range	-40°C ≤ T <sub>J</sub> ≤ +125°C
Output Current	15 mA

- (1) Absolute Maximum Ratings indicate limits beyond which damage to the device may occur. Operating Ratings indicate conditions for which the device is intended to be functional, but do not ensure specific performance limits. For ensured specifications and test conditions, see the Electrical Characteristics. The ensured specifications apply only for the test conditions listed. Some performance characteristics may degrade when the device is not operated under the listed test conditions.
- (2) The maximum power dissipation must be derated at elevated temperatures and is dictated by T<sub>Jmax</sub> (maximum junction temperature), θ<sub>JA</sub> (junction to ambient thermal resistance), and T<sub>A</sub> (ambient temperature). The maximum allowable power dissipation at any temperature is (P<sub>Dmax</sub> = T<sub>Jmax</sub> - T<sub>A</sub>)/θ<sub>JA</sub> or the number given in the Absolute Maximum Ratings, whichever is lower. The typical thermal resistance (θ<sub>JA</sub>) when soldered to a printed circuit board is approximately 306°C/W for the DBV package.

## LM3411-3.3 Electrical Characteristics

Specifications with standard type face are for T<sub>J</sub> = 25°C, and those with **boldface type** apply over **full Operating Temperature Range**. Unless otherwise specified, V(IN) = V<sub>REG</sub>, V<sub>OUT</sub> = 1.5V.

Symbol	Parameter	Conditions	Typical	LM3411A-3.3	LM3411-3.3	Units
			(1)	Limit	Limit	(Limits)
				(2)	(2)	
V <sub>REG</sub>	Regulation Voltage	I <sub>OUT</sub> = 5 mA	3.3	3.317/ <b>3.333</b>	3.333/ <b>3.366</b>	V
				3.284/ <b>3.267</b>	3.267/ <b>3.234</b>	V(max) V(min)
	Regulation Voltage Tolerance	I <sub>OUT</sub> = 5 mA		±0.5/ <b>±1</b>	±1/ <b>±2</b>	%(max)

- (1) Typical numbers are at 25°C and represent the most likely parametric norm.
- (2) Limits are 100% production tested at 25°C. Limits over the operating temperature range are ensured through correlation using Statistical Quality Control (SQC) methods. The limits are used to calculate TIs Averaging Outgoing Level (AOQL).

### LM3411-3.3 Electrical Characteristics (continued)

Specifications with standard type face are for  $T_J = 25^\circ\text{C}$ , and those with **boldface type** apply over **full Operating Temperature Range**. Unless otherwise specified,  $V(\text{IN}) = V_{\text{REG}}$ ,  $V_{\text{OUT}} = 1.5\text{V}$ .

Symbol	Parameter	Conditions	Typical	LM3411A-3.3	LM3411-3.3	Units
			(1)	Limit	Limit	(Limits)
				(2)	(2)	
$I_q$	Quiescent Current	$I_{\text{OUT}} = 5\text{ mA}$	85	<b>110/115</b>	<b>125/150</b>	$\mu\text{A}$ $\mu\text{A}(\text{max})$
$G_m$	Transconductance $\Delta I_{\text{OUT}}/\Delta V_{\text{REG}}$	$20\ \mu\text{A} \leq I_{\text{OUT}} \leq 1\ \text{mA}$	3.3	<b>1.5/0.75</b>	<b>1/0.50</b>	$\text{mA}/\text{mV}$ $\text{mA}/\text{mV}(\text{min})$
		$1\ \text{mA} \leq I_{\text{OUT}} \leq 15\ \text{mA}$	6.0	<b>3.3/2.0</b>	<b>2.5/1.7</b>	$\text{mA}/\text{mV}$ $\text{mA}/\text{mV}(\text{min})$
$A_V$	Voltage Gain $\Delta V_{\text{OUT}}/\Delta V_{\text{REG}}$	$1\text{V} \leq V_{\text{OUT}} \leq V_{\text{REG}} - 1.2\text{V}$ <b>(-1.3)</b> $R_L = 140\ \Omega$ <sup>(3)</sup>	1000	<b>550/250</b>	<b>450/200</b>	$\text{V}/\text{V}$ $\text{V}/\text{V}(\text{min})$
		$1\text{V} \leq V_{\text{OUT}} \leq V_{\text{REG}} - 1.2\text{V}$ <b>(-1.3)</b> $R_L = 2\ \text{k}\Omega$	3500	<b>1500/900</b>	<b>1000/700</b>	$\text{V}/\text{V}$ $\text{V}/\text{V}(\text{min})$
$V_{\text{SAT}}$	Output Saturation (4)	$V(\text{IN}) = V_{\text{REG}} + 100\ \text{mV}$ $I_{\text{OUT}} = 15\ \text{mA}$	1.0	<b>1.2/1.3</b>	<b>1.2/1.3</b>	$\text{V}$ $\text{V}(\text{max})$
$I_L$	Output Leakage Current	$V(\text{IN}) = V_{\text{REG}} - 100\ \text{mV}$ $V_{\text{OUT}} = 0\text{V}$	0.1	<b>0.5/1.0</b>	<b>0.5/1.0</b>	$\mu\text{A}$ $\mu\text{A}(\text{max})$
$R_f$	Internal Feedback Resistor <sup>(5)</sup>		52			$\text{k}\Omega$ $\text{k}\Omega(\text{max})$ $\text{k}\Omega(\text{min})$
				65 39	65 39	
$E_n$	Output Noise Voltage	$I_{\text{OUT}} = 1\ \text{mA}$ , $10\ \text{Hz} \leq f \leq 10\ \text{kHz}$	50			$\mu\text{V}_{\text{RMS}}$

(3) Actual test is done using equivalent current sink instead of a resistor load.

(4)  $V_{\text{SAT}} = V(\text{IN}) - V_{\text{OUT}}$ , when the voltage at the IN pin is forced 100 mV above the nominal regulating voltage ( $V_{\text{REG}}$ ).

(5) See [Applications Information](#) and [Typical Performance Characteristics](#) sections for information on this resistor.

### LM3411-5.0 Electrical Characteristics

Specifications with standard type face are for  $T_J = 25^\circ\text{C}$ , and those with **boldface type** apply over **full Operating Temperature Range**. Unless otherwise specified,  $V(\text{IN}) = V_{\text{REG}}$ ,  $V_{\text{OUT}} = 1.5\text{V}$ .

Symbol	Parameter	Conditions	Typical	LM3411A-5.0	LM3411-5.0	Units
			(1)	Limit	Limit	(Limits)
				(2)	(2)	
$V_{\text{REG}}$	Regulation Voltage	$I_{\text{OUT}} = 5\ \text{mA}$	5	<b>5.025/5.050</b>	<b>5.050/5.100</b>	$\text{V}$ $\text{V}(\text{max})$ $\text{V}(\text{min})$
				<b>4.975/4.950</b>	<b>4.950/4.900</b>	
	Regulation Voltage Tolerance	$I_{\text{OUT}} = 5\ \text{mA}$		<b><math>\pm 0.5/\pm 1</math></b>	<b><math>\pm 1/\pm 2</math></b>	$\%(\text{max})$
$I_q$	Quiescent Current	$I_{\text{OUT}} = 5\ \text{mA}$	85	<b>110/115</b>	<b>125/150</b>	$\mu\text{A}$ $\mu\text{A}(\text{max})$
$G_m$	Transconductance $\Delta I_{\text{OUT}}/\Delta V_{\text{REG}}$	$20\ \mu\text{A} \leq I_{\text{OUT}} \leq 1\ \text{mA}$	3.3	<b>1.5/0.75</b>	<b>1.0/0.5</b>	$\text{mA}/\text{mV}$ $\text{mA}/\text{mV}(\text{min})$
		$1\ \text{mA} \leq I_{\text{OUT}} \leq 15\ \text{mA}$	6.0			$\text{mA}/\text{mV}$ $\text{mA}/\text{mV}(\text{min})$
				<b>3.3/2.0</b>	<b>2.5/1.7</b>	

(1) Typical numbers are at  $25^\circ\text{C}$  and represent the most likely parametric norm.

(2) Limits are 100% production tested at  $25^\circ\text{C}$ . Limits over the operating temperature range are ensured through correlation using Statistical Quality Control (SQC) methods. The limits are used to calculate TIs Averaging Outgoing Level (AOQL).

**LM3411-5.0 Electrical Characteristics (continued)**

Specifications with standard type face are for  $T_J = 25^\circ\text{C}$ , and those with **boldface type** apply over **full Operating Temperature Range**. Unless otherwise specified,  $V(\text{IN}) = V_{\text{REG}}$ ,  $V_{\text{OUT}} = 1.5\text{V}$ .

Symbol	Parameter	Conditions	Typical	LM3411A-5.0	LM3411-5.0	Units
			(1)	Limit	Limit	(Limits)
				(2)	(2)	
$A_V$	Voltage Gain $\Delta V_{\text{OUT}}/\Delta V_{\text{REG}}$	$1\text{V} \leq V_{\text{OUT}} \leq V_{\text{REG}} - 1.2\text{V}$ ( <b>-1.3</b> )	1000			V/V
		$R_L = 250\Omega$ <sup>(3)</sup>		<b>750/350</b>	<b>650/300</b>	V/V(min)
		$1\text{V} \leq V_{\text{OUT}} \leq V_{\text{REG}} - 1.2\text{V}$ ( <b>-1.3</b> ) $R_L = 2\text{ k}\Omega$	3500	<b>1500/900</b>	<b>1000/700</b>	V/V V/V(min)
$V_{\text{SAT}}$	Output Saturation (4)	$V(\text{IN}) = V_{\text{REG}} + 100\text{ mV}$ $I_{\text{OUT}} = 15\text{ mA}$	1.0	<b>1.2/1.3</b>	<b>1.2/1.3</b>	V V(max)
$I_L$	Output Leakage Current	$V(\text{IN}) = V_{\text{REG}} - 100\text{ mV}$ $V_{\text{OUT}} = 0\text{V}$	0.1	<b>0.5/1.0</b>	<b>0.5/1.0</b>	$\mu\text{A}$ $\mu\text{A}(\text{max})$
$R_f$	Internal Feedback Resistor <sup>(5)</sup>		94			$\text{k}\Omega$
				118	118	$\text{k}\Omega(\text{max})$
				70	70	$\text{k}\Omega(\text{min})$
$E_n$	Output Noise Voltage	$I_{\text{OUT}} = 1\text{ mA}$ , $10\text{ Hz} \leq f \leq 10\text{ kHz}$	80			$\mu\text{V}_{\text{RMS}}$

(3) Actual test is done using equivalent current sink instead of a resistor load.

(4)  $V_{\text{SAT}} = V(\text{IN}) - V_{\text{OUT}}$ , when the voltage at the IN pin is forced 100 mV above the nominal regulating voltage ( $V_{\text{REG}}$ ).

(5) See [Applications Information](#) and [Typical Performance Characteristics](#) sections for information on this resistor.

### Typical Performance Characteristics

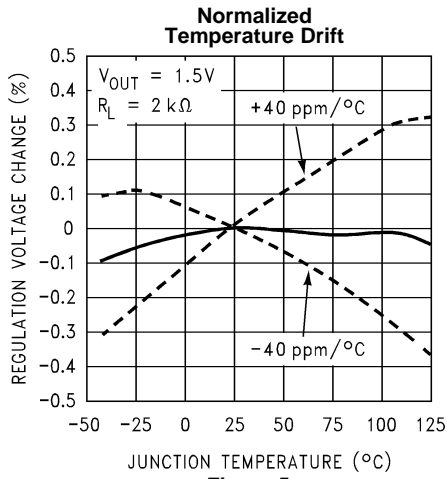

Figure 5.

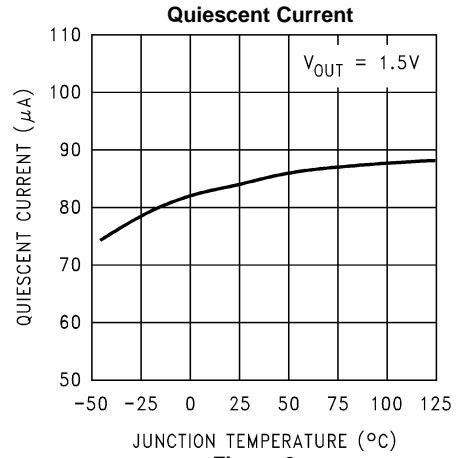

Figure 6.

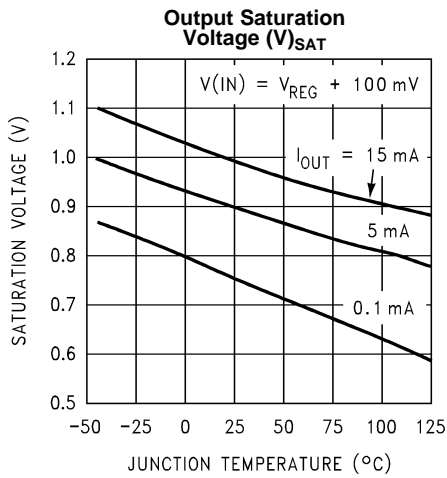

Figure 7.

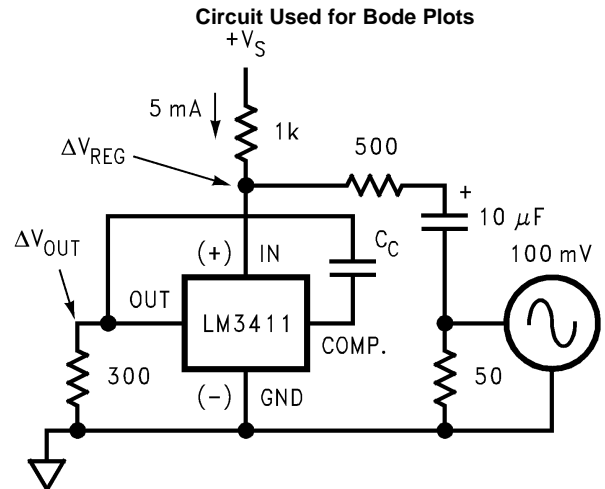

Figure 8.

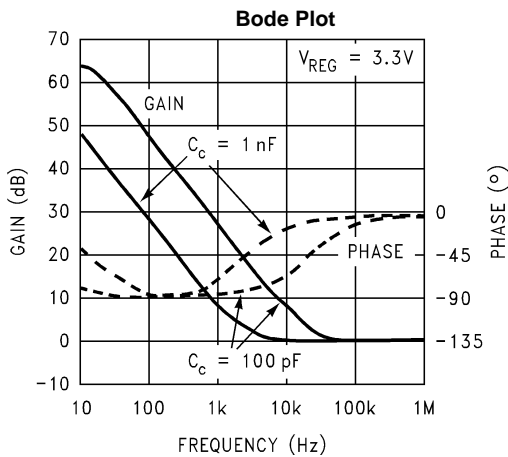

Figure 9.

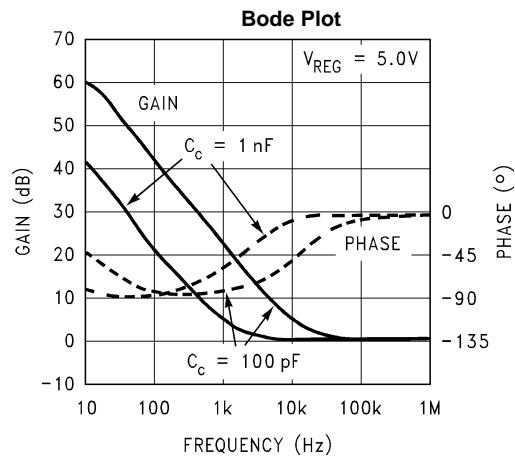

Figure 10.

Typical Performance Characteristics (continued)

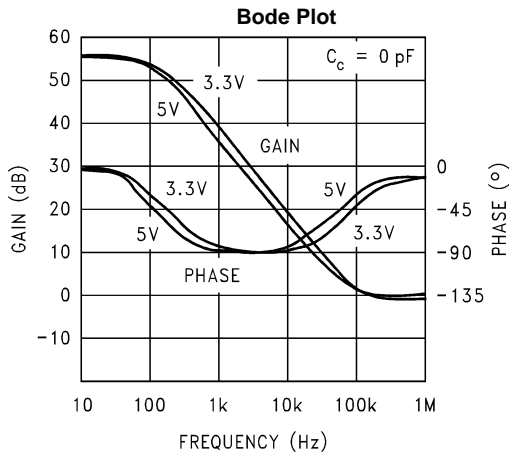

Figure 11.

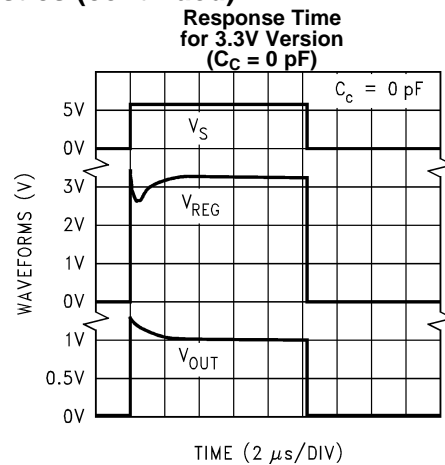

Figure 12.

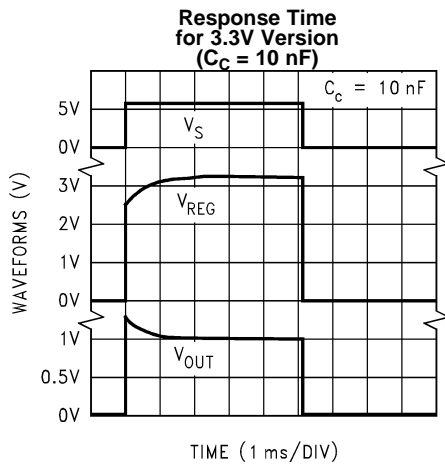

Figure 13.

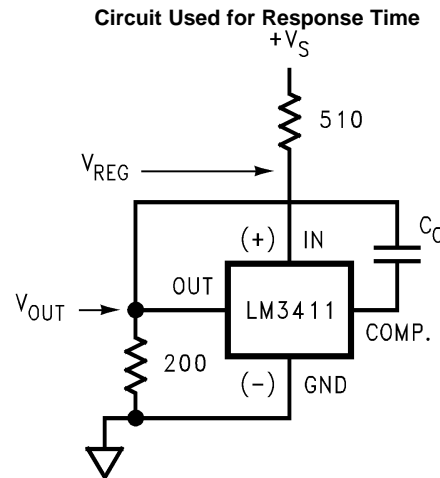

Figure 14.

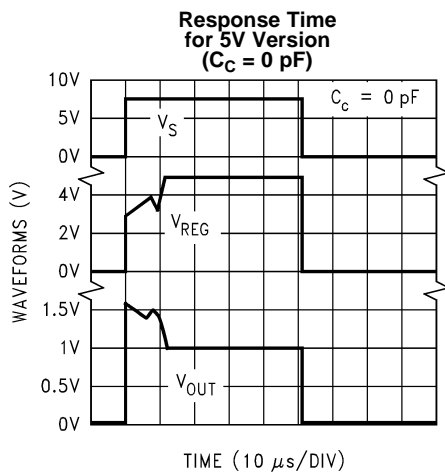

Figure 15.

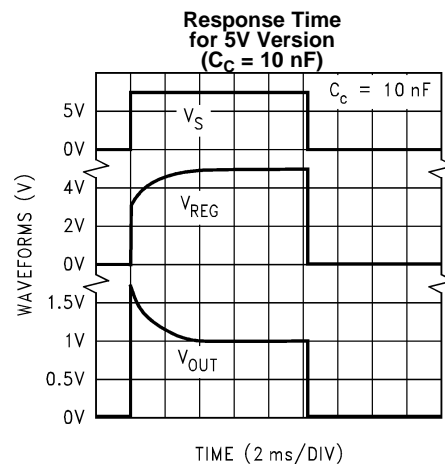

Figure 16.

Typical Performance Characteristics (continued)

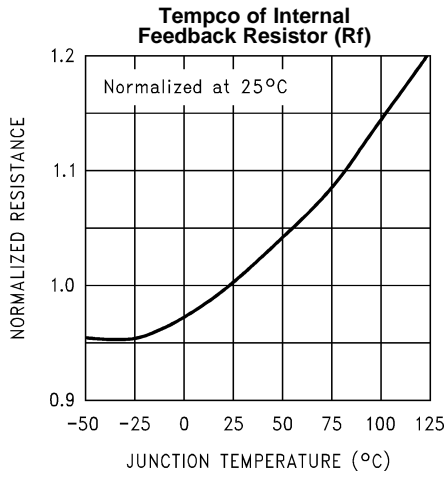

Figure 17.

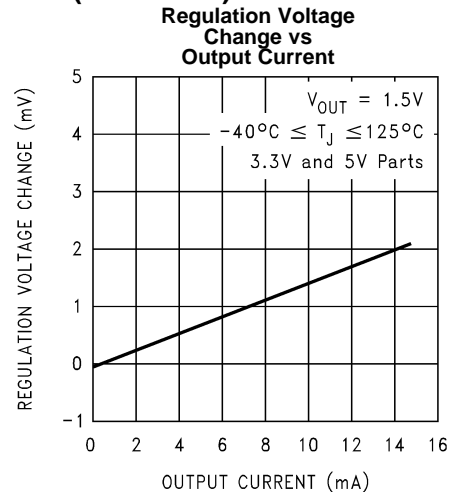

Figure 18.

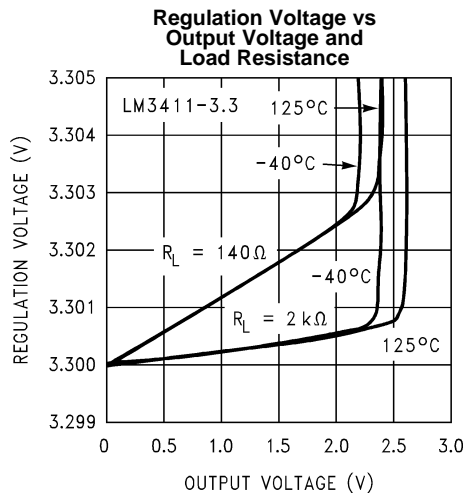

Figure 19.

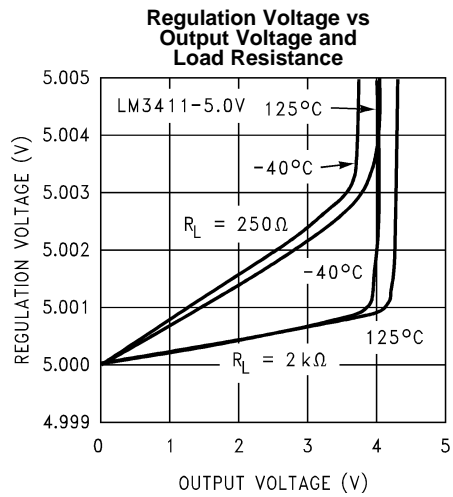

Figure 20.



## PRODUCT DESCRIPTION

The LM3411 is a shunt regulator specifically designed to be the reference and control section in an overall feedback loop of a regulated power supply. The regulated output voltage is sensed between the IN pin and GROUND pin of the LM3411. If the voltage at the IN pin is less than the LM3411 regulating voltage ( $V_{REG}$ ), the OUT pin sources no current. As the voltage at the IN pin approaches the  $V_{REG}$  voltage, the OUT pin begins sourcing current. This current is then used to drive a feedback device, (opto-coupler) or a power device, (linear regulator, switching regulator, etc.) which servos the output voltage to be the same value as  $V_{REG}$ .

In some applications, (even under normal operating conditions) the voltage on the IN pin can be forced above the  $V_{REG}$  voltage. In these instances, the maximum voltage applied to the IN pin should not exceed 20V. In addition, an external resistor may be required on the OUT pin to limit the maximum current to 20 mA.

### Compensation

The inverting input of the error amplifier is brought out to allow overall closed-loop compensation. In many of the applications circuits shown here, compensation is provided by a single capacitor connected from the compensation pin to the out pin of the LM3411. The capacitor values shown in the schematics are adequate under most conditions, but they can be increased or decreased depending on the desired loop response. Applying a load pulse to the output of a regulator circuit and observing the resultant output voltage response is a easy method of determining the stability of the control loop. Analyzing more complex feedback loops requires additional information.

The formula for AC gain at a frequency (f) is as follows;

$$\text{Gain (f)} = 1 + \frac{Z_f(f)}{R_f}$$

$$\text{where } Z_f(f) = \frac{1}{j \cdot 2\pi \cdot f \cdot C}$$

where

- $R_f \approx 52 \text{ k}\Omega$  for the 3.3V part
  - $R_f \approx 94 \text{ k}\Omega$  for the 5V part
- (1)

The resistor ( $R_f$ ) in the formula is an internal resistor located on the die. Since this resistor value will affect the phase margin, the worst case maximum and minimum values are important when analyzing closed loop stability. The minimum and maximum room temperature values of this resistor are specified in the [Electrical Characteristics](#) section of this data sheet, and a curve showing the temperature coefficient is shown in the [Typical Performance Characteristics](#) section. In the applications shown here, the worst case phase margin occurs with minimum values of  $R_f$ .

### Test Circuit

The test circuit shown in [Figure 21](#) can be used to measure and verify various LM3411 parameters. Test conditions are set by forcing the appropriate voltage at the  $V_{OUT}$  Set test point and selecting the appropriate  $R_L$  or  $I_{OUT}$  as specified in the [Electrical Characteristics](#) section. Use a DVM at the “measure” test points to read the data.

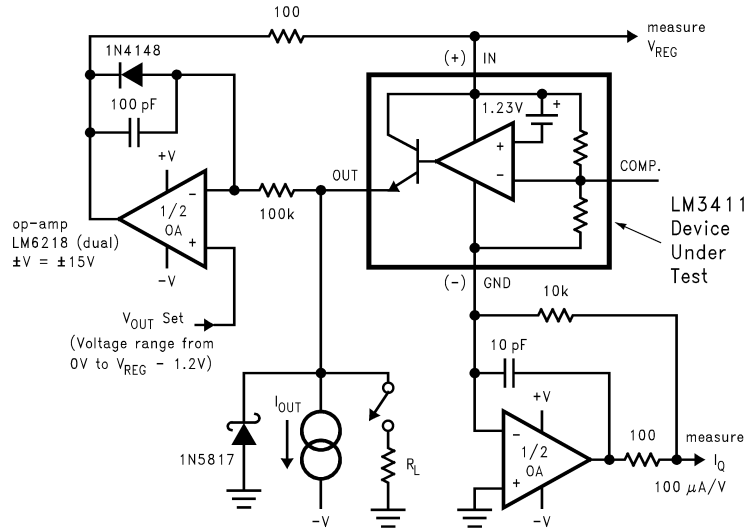

Figure 21. LM3411 Test Circuit

Applications Information

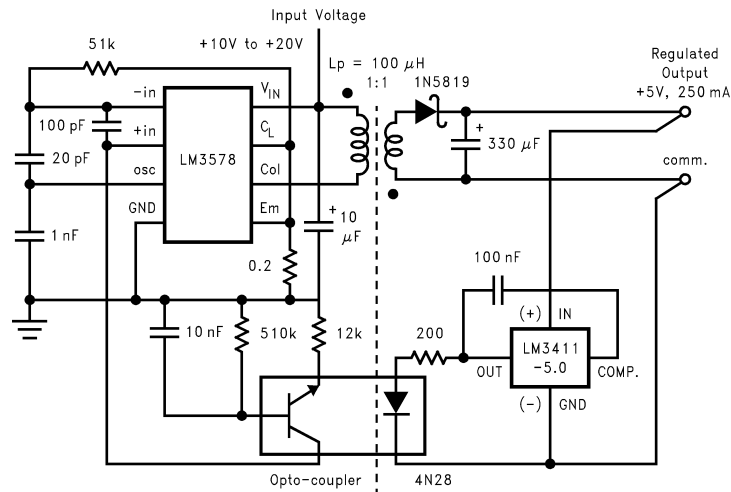

Figure 22. Isolated 250 mA Flyback Switching Regulator

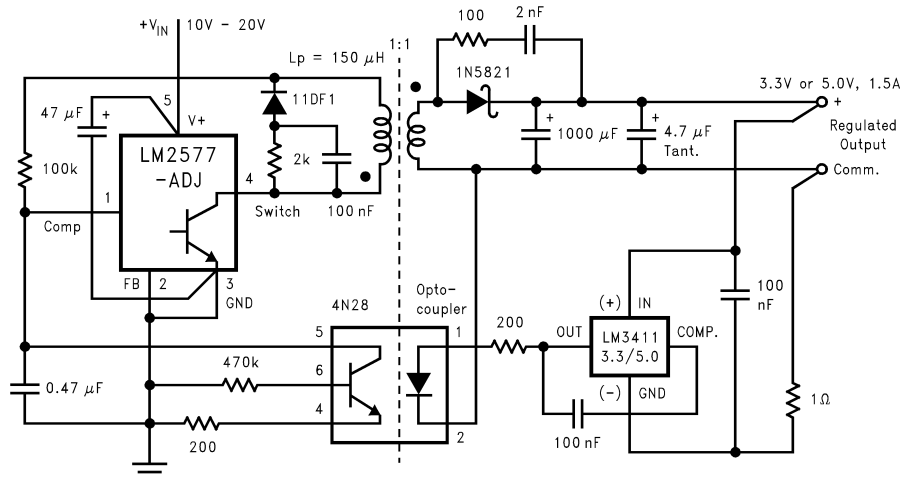

Figure 23. Isolated 1.5A Flyback Switching Regulator Using a LM2577

The LM3411 regulator/driver provides the reference and feedback drive functions in a regulated power supply. It can also be used together with many different types of regulators, (both linear and switching) as well as other power semiconductor devices to add precision and improve regulation specifications. Output voltage tolerances better than 0.5% are possible without using trim pots or precision resistors.

One of the main applications of the LM3411 is to drive an opto-isolator to provide feedback signal isolation in a switching regulator circuit. For low current applications, (up to 250 mA) the circuit shown in [Figure 22](#) provides good regulation and complete input/output electrical isolation.

For an input voltage of 15V, this circuit can provide an output of either 3.3V or 5V with a load current up to 250 mA with excellent regulation characteristics. With the part values shown, this circuit operates at 80 kHz., and can be synchronized to a clock or an additional LM3578. (See LM3578 data sheet for additional information.)

An isolated DC/DC flyback converter capable of higher output current is shown in [Figure 23](#). This circuit utilizes the LM2577 SIMPLE SWITCHER voltage regulator for the Pulse Width Modulation (PWM), power switch and protection functions, while the LM3411 provides the voltage reference, gain and opto coupler drive functions. In this circuit, the reference and error amplifier in the LM2577 are not used (note that the feedback pin is grounded). The gain is provided by the LM3411. Since the voltage reference is located on the secondary side of the transformer, this circuit provides very good regulation specifications.

The output of a switching regulator typically will contain a small ripple voltage at the switching frequency and may also contain voltage transients. These transient voltage spikes can be sensed by the LM3411 and could give an incorrect regulation voltage. An RC filter consisting of a 1Ω resistor and a 100 nF capacitor will filter these transients and minimize this problem. The 1Ω resistor should be located on the ground side of the LM3411, and the capacitor should be physically located near the package.

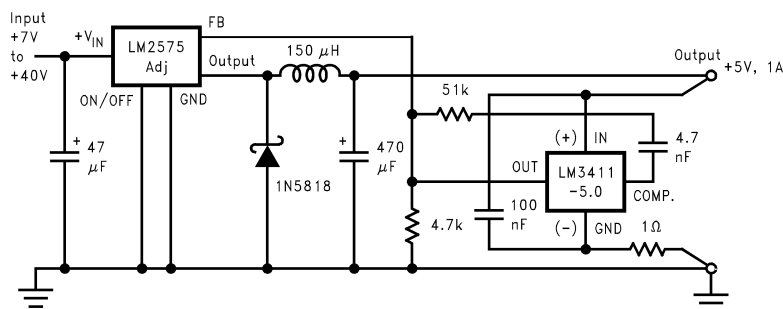

Figure 24. Precision 1A Buck Regulator



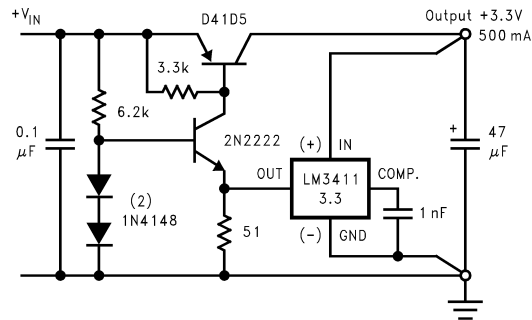

Figure 27. 3.3V 0.5A Low Dropout Regulator

The circuit in [Figure 27](#) shows a 3.3V low dropout regulator using the LM3411-3.3 and several discrete components. This circuit is capable of excellent performance with both the dropout voltage and the ground pin current specifications improved over the LM2941/LM3411 circuit.

The standard LM317 three terminal adjustable regulator circuit can greatly benefit by adding a LM3411. Performance is increased and features are added. The circuit shown in [Figure 28](#) provides much improved line and load regulation, lower temperature drift, and full remote output voltage sensing on both the high and low side. In addition, a precise current limit or constant current feature is simple to add.

Current limit protection in most IC regulators is mainly to protect the IC from gross over-current conditions which could otherwise fuse bonding wires or blow IC metalization, therefore not much precision is needed for the actual current limit values. Current limit tolerances can sometimes vary from  $\pm 10\%$  to as high as  $+300\%$  over manufacturing and temperature variations. Often critical circuitry requires a much tighter control over the amount of current the power supply can deliver. For example, a power supply may be needed that can deliver 100% of its design current, but can still limit the maximum current to 110% to protect critical circuitry from high current fault conditions.

The circuit in [Figure 28](#) can provide a current limit accuracy that is better than  $\pm 4\%$ , over all possible variations, in addition to having excellent line, load and temperature specifications.

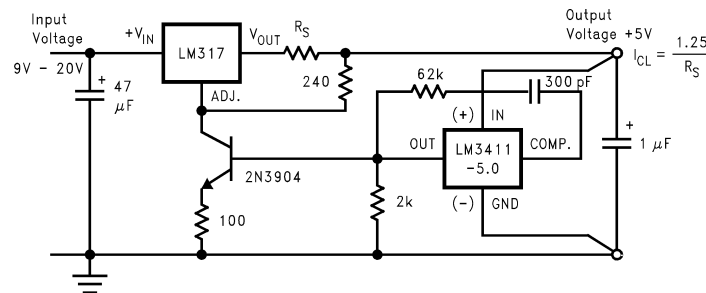
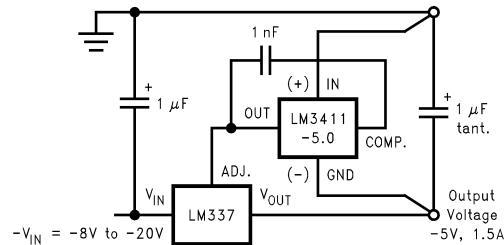
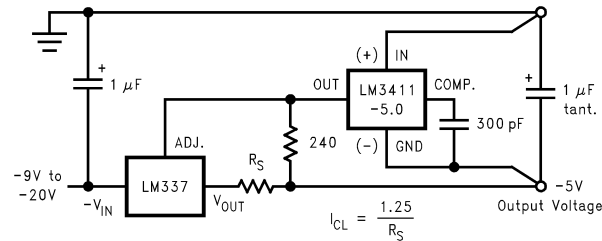

Figure 28. Precision Positive Voltage Regulator with Accurate Current Limit

Like the positive regulators, the performance of negative adjustable regulators can also be improved by adding the LM3411. Output voltages of either 3.3V or 5V at currents up to 1.5A (3A when using a LM333) are possible. Adding two resistors to the circuit in [Figure 29](#) adds the precision current limit feature as shown in [Figure 30](#). Current limit tolerances of  $\pm 4\%$  over manufacturing and temperature variations are possible with this circuit.

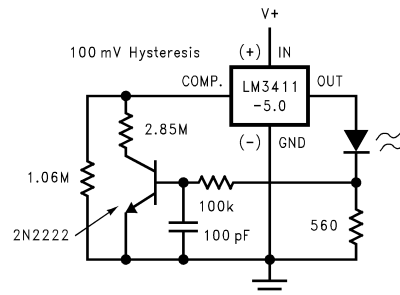

**Figure 29. Precision Negative Voltage Regulator**



**Figure 30. Precision Negative Voltage Regulator with Accurate Current Limit**

A simple 5V supply monitor circuit is shown in [Figure 31](#). Using the LM3411's voltage reference, op-amp (as a comparator) and output driver, this circuit provides a LED indication of the presence of the 5V supply.



**Figure 31. 4.7V Power ON Detector with Hysteresis**

The LM3411 initial room temperature tolerance is  $\pm 1\%$  and  $\pm 0.5\%$  for the "A" grade part. If a tighter tolerance is needed, a trim scheme is shown in [Figure 32](#) that provides approximately  $\pm 1\%$  adjustment range of the regulation voltage ( $V_{REG}$ ).

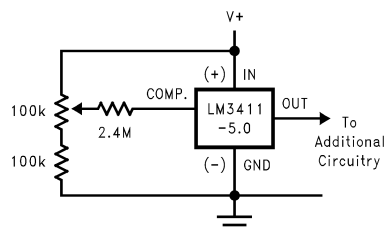

**Figure 32.  $\pm 50$  mV External Trim**

The LM3411 is ensured to drive a 15 mA load, but if more current is needed, a NPN boost transistor can be added. The circuit shown in [Figure 33](#) is a shunt regulator capable of providing excellent regulation over a very wide range of current.

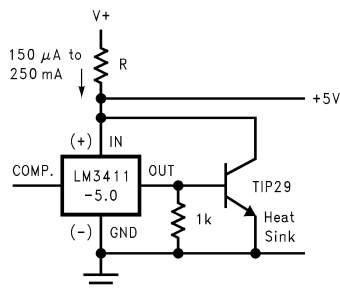

Figure 33. 250 mA Shunt Regulator

Perhaps one of the simplest applications for the LM3411 is the voltage detector circuit shown in [Figure 34](#). The OUT pin is low when the input voltage is less than  $V_{REG}$ . When the  $V(IN)$  pin rises above  $V_{REG}$ , the OUT pin is pulled high by the internal NPN output resistor.

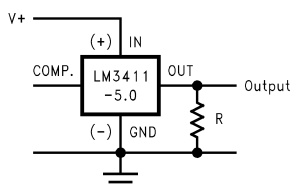

Figure 34. Voltage Detector

Also an overvoltage detector, the crowbar circuit shown in [Figure 35](#) is normally located at the output of a power supply to protect the load from an overvoltage condition should the power supply fail with an input/output short.

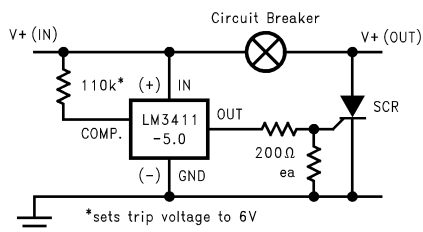
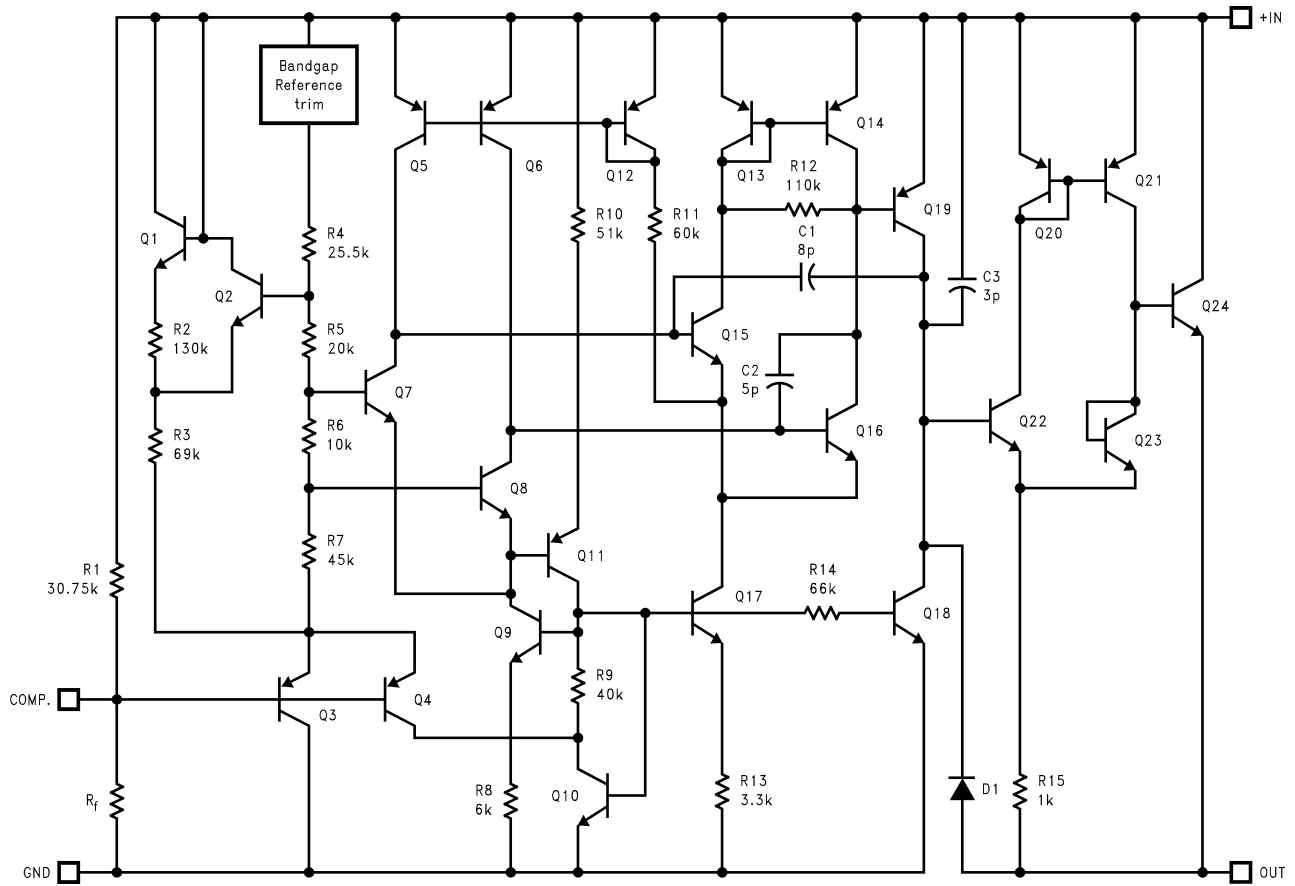

Figure 35. Overvoltage Crowbar

Schematic Diagram





---

**REVISION HISTORY**

<b>Changes from Revision D (April 2013) to Revision E</b>	<b>Page</b>
<hr/> <ul style="list-style-type: none"><li>• Changed layout of National Data Sheet to TI format .....</li></ul>	<hr/> <a href="#">16</a>

**PACKAGING INFORMATION**

Orderable Device	Status (1)	Package Type	Package Drawing	Pins	Package Qty	Eco Plan (2)	Lead/Ball Finish (6)	MSL Peak Temp (3)	Op Temp (°C)	Device Marking (4/5)	Samples
LM3411AM5-3.3/NOPB	ACTIVE	SOT-23	DBV	5	1000	Green (RoHS & no Sb/Br)	CU SN	Level-1-260C-UNLIM	-40 to 85	D00A	<a href="#">Samples</a>
LM3411AM5-5.0	NRND	SOT-23	DBV	5	1000	TBD	Call TI	Call TI	-40 to 85	D01A	
LM3411AM5-5.0/NOPB	ACTIVE	SOT-23	DBV	5	1000	Green (RoHS & no Sb/Br)	CU SN	Level-1-260C-UNLIM	-40 to 85	D01A	<a href="#">Samples</a>
LM3411AM5X-3.3/NOPB	ACTIVE	SOT-23	DBV	5	3000	Green (RoHS & no Sb/Br)	CU SN	Level-1-260C-UNLIM	-40 to 85	D00A	<a href="#">Samples</a>
LM3411AM5X-5.0/NOPB	ACTIVE	SOT-23	DBV	5	3000	Green (RoHS & no Sb/Br)	CU SN	Level-1-260C-UNLIM	-40 to 85	D01A	<a href="#">Samples</a>
LM3411M5-3.3/NOPB	ACTIVE	SOT-23	DBV	5	1000	Green (RoHS & no Sb/Br)	CU SN	Level-1-260C-UNLIM	-40 to 85	D00B	<a href="#">Samples</a>
LM3411M5-5.0	NRND	SOT-23	DBV	5	1000	TBD	Call TI	Call TI	-40 to 85	D01B	
LM3411M5-5.0/NOPB	ACTIVE	SOT-23	DBV	5	1000	Green (RoHS & no Sb/Br)	CU SN	Level-1-260C-UNLIM	-40 to 85	D01B	<a href="#">Samples</a>
LM3411M5X-3.3/NOPB	ACTIVE	SOT-23	DBV	5	3000	Green (RoHS & no Sb/Br)	CU SN	Level-1-260C-UNLIM	-40 to 85	D00B	<a href="#">Samples</a>
LM3411M5X-5.0/NOPB	ACTIVE	SOT-23	DBV	5	3000	Green (RoHS & no Sb/Br)	CU SN	Level-1-260C-UNLIM	-40 to 85	D01B	<a href="#">Samples</a>

(1) The marketing status values are defined as follows:

**ACTIVE:** Product device recommended for new designs.

**LIFEBUY:** TI has announced that the device will be discontinued, and a lifetime-buy period is in effect.

**NRND:** Not recommended for new designs. Device is in production to support existing customers, but TI does not recommend using this part in a new design.

**PREVIEW:** Device has been announced but is not in production. Samples may or may not be available.

**OBSOLETE:** TI has discontinued the production of the device.

(2) Eco Plan - The planned eco-friendly classification: Pb-Free (RoHS), Pb-Free (RoHS Exempt), or Green (RoHS & no Sb/Br) - please check <http://www.ti.com/productcontent> for the latest availability information and additional product content details.

**TBD:** The Pb-Free/Green conversion plan has not been defined.

**Pb-Free (RoHS):** TI's terms "Lead-Free" or "Pb-Free" mean semiconductor products that are compatible with the current RoHS requirements for all 6 substances, including the requirement that lead not exceed 0.1% by weight in homogeneous materials. Where designed to be soldered at high temperatures, TI Pb-Free products are suitable for use in specified lead-free processes.

**Pb-Free (RoHS Exempt):** This component has a RoHS exemption for either 1) lead-based flip-chip solder bumps used between the die and package, or 2) lead-based die adhesive used between the die and leadframe. The component is otherwise considered Pb-Free (RoHS compatible) as defined above.

**Green (RoHS & no Sb/Br):** TI defines "Green" to mean Pb-Free (RoHS compatible), and free of Bromine (Br) and Antimony (Sb) based flame retardants (Br or Sb do not exceed 0.1% by weight in homogeneous material)

- (3) MSL, Peak Temp. - The Moisture Sensitivity Level rating according to the JEDEC industry standard classifications, and peak solder temperature.
- (4) There may be additional marking, which relates to the logo, the lot trace code information, or the environmental category on the device.
- (5) Multiple Device Markings will be inside parentheses. Only one Device Marking contained in parentheses and separated by a "~" will appear on a device. If a line is indented then it is a continuation of the previous line and the two combined represent the entire Device Marking for that device.
- (6) Lead/Ball Finish - Orderable Devices may have multiple material finish options. Finish options are separated by a vertical ruled line. Lead/Ball Finish values may wrap to two lines if the finish value exceeds the maximum column width.

**Important Information and Disclaimer:**The information provided on this page represents TI's knowledge and belief as of the date that it is provided. TI bases its knowledge and belief on information provided by third parties, and makes no representation or warranty as to the accuracy of such information. Efforts are underway to better integrate information from third parties. TI has taken and continues to take reasonable steps to provide representative and accurate information but may not have conducted destructive testing or chemical analysis on incoming materials and chemicals. TI and TI suppliers consider certain information to be proprietary, and thus CAS numbers and other limited information may not be available for release.

In no event shall TI's liability arising out of such information exceed the total purchase price of the TI part(s) at issue in this document sold by TI to Customer on an annual basis.

**TAPE AND REEL INFORMATION**

**QUADRANT ASSIGNMENTS FOR PIN 1 ORIENTATION IN TAPE**

\*All dimensions are nominal

Device	Package Type	Package Drawing	Pins	SPQ	Reel Diameter (mm)	Reel Width W1 (mm)	A0 (mm)	B0 (mm)	K0 (mm)	P1 (mm)	W (mm)	Pin1 Quadrant
LM3411AM5-3.3/NOPB	SOT-23	DBV	5	1000	178.0	8.4	3.2	3.2	1.4	4.0	8.0	Q3
LM3411AM5-5.0	SOT-23	DBV	5	1000	178.0	8.4	3.2	3.2	1.4	4.0	8.0	Q3
LM3411AM5-5.0/NOPB	SOT-23	DBV	5	1000	178.0	8.4	3.2	3.2	1.4	4.0	8.0	Q3
LM3411AM5X-3.3/NOPB	SOT-23	DBV	5	3000	178.0	8.4	3.2	3.2	1.4	4.0	8.0	Q3
LM3411AM5X-5.0/NOPB	SOT-23	DBV	5	3000	178.0	8.4	3.2	3.2	1.4	4.0	8.0	Q3
LM3411M5-3.3/NOPB	SOT-23	DBV	5	1000	178.0	8.4	3.2	3.2	1.4	4.0	8.0	Q3
LM3411M5-5.0	SOT-23	DBV	5	1000	178.0	8.4	3.2	3.2	1.4	4.0	8.0	Q3
LM3411M5-5.0/NOPB	SOT-23	DBV	5	1000	178.0	8.4	3.2	3.2	1.4	4.0	8.0	Q3
LM3411M5X-3.3/NOPB	SOT-23	DBV	5	3000	178.0	8.4	3.2	3.2	1.4	4.0	8.0	Q3
LM3411M5X-5.0/NOPB	SOT-23	DBV	5	3000	178.0	8.4	3.2	3.2	1.4	4.0	8.0	Q3

**TAPE AND REEL BOX DIMENSIONS**

\*All dimensions are nominal

Device	Package Type	Package Drawing	Pins	SPQ	Length (mm)	Width (mm)	Height (mm)
LM3411AM5-3.3/NOPB	SOT-23	DBV	5	1000	210.0	185.0	35.0
LM3411AM5-5.0	SOT-23	DBV	5	1000	210.0	185.0	35.0
LM3411AM5-5.0/NOPB	SOT-23	DBV	5	1000	210.0	185.0	35.0
LM3411AM5X-3.3/NOPB	SOT-23	DBV	5	3000	210.0	185.0	35.0
LM3411AM5X-5.0/NOPB	SOT-23	DBV	5	3000	210.0	185.0	35.0
LM3411M5-3.3/NOPB	SOT-23	DBV	5	1000	210.0	185.0	35.0
LM3411M5-5.0	SOT-23	DBV	5	1000	210.0	185.0	35.0
LM3411M5-5.0/NOPB	SOT-23	DBV	5	1000	210.0	185.0	35.0
LM3411M5X-3.3/NOPB	SOT-23	DBV	5	3000	210.0	185.0	35.0
LM3411M5X-5.0/NOPB	SOT-23	DBV	5	3000	210.0	185.0	35.0

DBV (R-PDSO-G5)

PLASTIC SMALL-OUTLINE PACKAGE

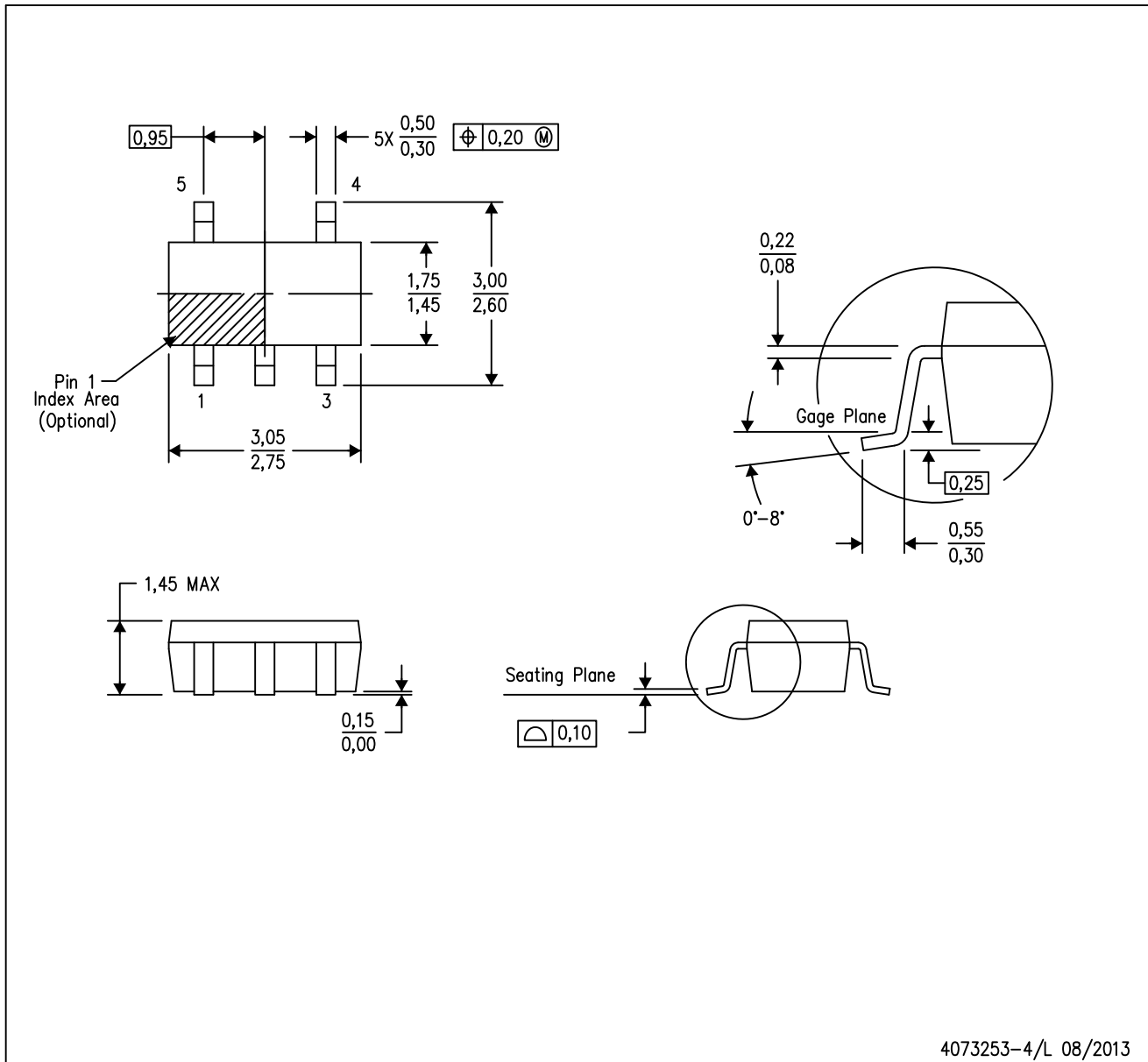

- NOTES:
- A. All linear dimensions are in millimeters.
  - B. This drawing is subject to change without notice.
  - C. Body dimensions do not include mold flash or protrusion. Mold flash and protrusion shall not exceed 0.15 per side.
  - D. Falls within JEDEC MO-178 Variation AA.

DBV (R-PDSO-G5)

PLASTIC SMALL OUTLINE



- NOTES:
- A. All linear dimensions are in millimeters.
  - B. This drawing is subject to change without notice.
  - C. Customers should place a note on the circuit board fabrication drawing not to alter the center solder mask defined pad.
  - D. Publication IPC-7351 is recommended for alternate designs.
  - E. Laser cutting apertures with trapezoidal walls and also rounding corners will offer better paste release. Customers should contact their board assembly site for stencil design recommendations. Example stencil design based on a 50% volumetric metal load solder paste. Refer to IPC-7525 for other stencil recommendations.

## IMPORTANT NOTICE

Texas Instruments Incorporated and its subsidiaries (TI) reserve the right to make corrections, enhancements, improvements and other changes to its semiconductor products and services per JESD46, latest issue, and to discontinue any product or service per JESD48, latest issue. Buyers should obtain the latest relevant information before placing orders and should verify that such information is current and complete. All semiconductor products (also referred to herein as "components") are sold subject to TI's terms and conditions of sale supplied at the time of order acknowledgment.

TI warrants performance of its components to the specifications applicable at the time of sale, in accordance with the warranty in TI's terms and conditions of sale of semiconductor products. Testing and other quality control techniques are used to the extent TI deems necessary to support this warranty. Except where mandated by applicable law, testing of all parameters of each component is not necessarily performed.

TI assumes no liability for applications assistance or the design of Buyers' products. Buyers are responsible for their products and applications using TI components. To minimize the risks associated with Buyers' products and applications, Buyers should provide adequate design and operating safeguards.

TI does not warrant or represent that any license, either express or implied, is granted under any patent right, copyright, mask work right, or other intellectual property right relating to any combination, machine, or process in which TI components or services are used. Information published by TI regarding third-party products or services does not constitute a license to use such products or services or a warranty or endorsement thereof. Use of such information may require a license from a third party under the patents or other intellectual property of the third party, or a license from TI under the patents or other intellectual property of TI.

Reproduction of significant portions of TI information in TI data books or data sheets is permissible only if reproduction is without alteration and is accompanied by all associated warranties, conditions, limitations, and notices. TI is not responsible or liable for such altered documentation. Information of third parties may be subject to additional restrictions.

Resale of TI components or services with statements different from or beyond the parameters stated by TI for that component or service voids all express and any implied warranties for the associated TI component or service and is an unfair and deceptive business practice. TI is not responsible or liable for any such statements.

Buyer acknowledges and agrees that it is solely responsible for compliance with all legal, regulatory and safety-related requirements concerning its products, and any use of TI components in its applications, notwithstanding any applications-related information or support that may be provided by TI. Buyer represents and agrees that it has all the necessary expertise to create and implement safeguards which anticipate dangerous consequences of failures, monitor failures and their consequences, lessen the likelihood of failures that might cause harm and take appropriate remedial actions. Buyer will fully indemnify TI and its representatives against any damages arising out of the use of any TI components in safety-critical applications.

In some cases, TI components may be promoted specifically to facilitate safety-related applications. With such components, TI's goal is to help enable customers to design and create their own end-product solutions that meet applicable functional safety standards and requirements. Nonetheless, such components are subject to these terms.

No TI components are authorized for use in FDA Class III (or similar life-critical medical equipment) unless authorized officers of the parties have executed a special agreement specifically governing such use.

Only those TI components which TI has specifically designated as military grade or "enhanced plastic" are designed and intended for use in military/aerospace applications or environments. Buyer acknowledges and agrees that any military or aerospace use of TI components which have **not** been so designated is solely at the Buyer's risk, and that Buyer is solely responsible for compliance with all legal and regulatory requirements in connection with such use.

TI has specifically designated certain components as meeting ISO/TS16949 requirements, mainly for automotive use. In any case of use of non-designated products, TI will not be responsible for any failure to meet ISO/TS16949.

### Products

Audio	<a href="http://www.ti.com/audio">www.ti.com/audio</a>
Amplifiers	<a href="http://amplifier.ti.com">amplifier.ti.com</a>
Data Converters	<a href="http://dataconverter.ti.com">dataconverter.ti.com</a>
DLP® Products	<a href="http://www.dlp.com">www.dlp.com</a>
DSP	<a href="http://dsp.ti.com">dsp.ti.com</a>
Clocks and Timers	<a href="http://www.ti.com/clocks">www.ti.com/clocks</a>
Interface	<a href="http://interface.ti.com">interface.ti.com</a>
Logic	<a href="http://logic.ti.com">logic.ti.com</a>
Power Mgmt	<a href="http://power.ti.com">power.ti.com</a>
Microcontrollers	<a href="http://microcontroller.ti.com">microcontroller.ti.com</a>
RFID	<a href="http://www.ti-rfid.com">www.ti-rfid.com</a>
OMAP Applications Processors	<a href="http://www.ti.com/omap">www.ti.com/omap</a>
Wireless Connectivity	<a href="http://www.ti.com/wirelessconnectivity">www.ti.com/wirelessconnectivity</a>

### Applications

Automotive and Transportation	<a href="http://www.ti.com/automotive">www.ti.com/automotive</a>
Communications and Telecom	<a href="http://www.ti.com/communications">www.ti.com/communications</a>
Computers and Peripherals	<a href="http://www.ti.com/computers">www.ti.com/computers</a>
Consumer Electronics	<a href="http://www.ti.com/consumer-apps">www.ti.com/consumer-apps</a>
Energy and Lighting	<a href="http://www.ti.com/energy">www.ti.com/energy</a>
Industrial	<a href="http://www.ti.com/industrial">www.ti.com/industrial</a>
Medical	<a href="http://www.ti.com/medical">www.ti.com/medical</a>
Security	<a href="http://www.ti.com/security">www.ti.com/security</a>
Space, Avionics and Defense	<a href="http://www.ti.com/space-avionics-defense">www.ti.com/space-avionics-defense</a>
Video and Imaging	<a href="http://www.ti.com/video">www.ti.com/video</a>

### TI E2E Community

[e2e.ti.com](http://e2e.ti.com)



# Mouser Electronics

Authorized Distributor

Click to View Pricing, Inventory, Delivery & Lifecycle Information:

## Texas Instruments:

[LM3411AM5-3.3/NOPB](#) [LM3411AM5-5.0](#) [LM3411AM5-5.0/NOPB](#) [LM3411AM5X-3.3/NOPB](#) [LM3411AM5X-5.0/NOPB](#) [LM3411M5-3.3/NOPB](#) [LM3411M5-5.0](#) [LM3411M5-5.0/NOPB](#) [LM3411M5X-3.3/NOPB](#) [LM3411M5X-5.0/NOPB](#)