

# ASSEMBLIES AVAILABLE BY SPECIAL ORDER - NAFTA REGION ONLY.

REV.	MODIFICATION.	DATE	DRN
01	PRODUCTION RELEASE	29/09/08	MT
02	CO2010497	03/12/08	SF

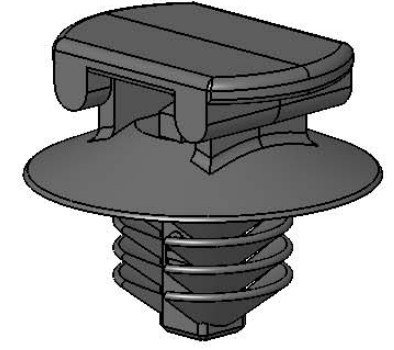
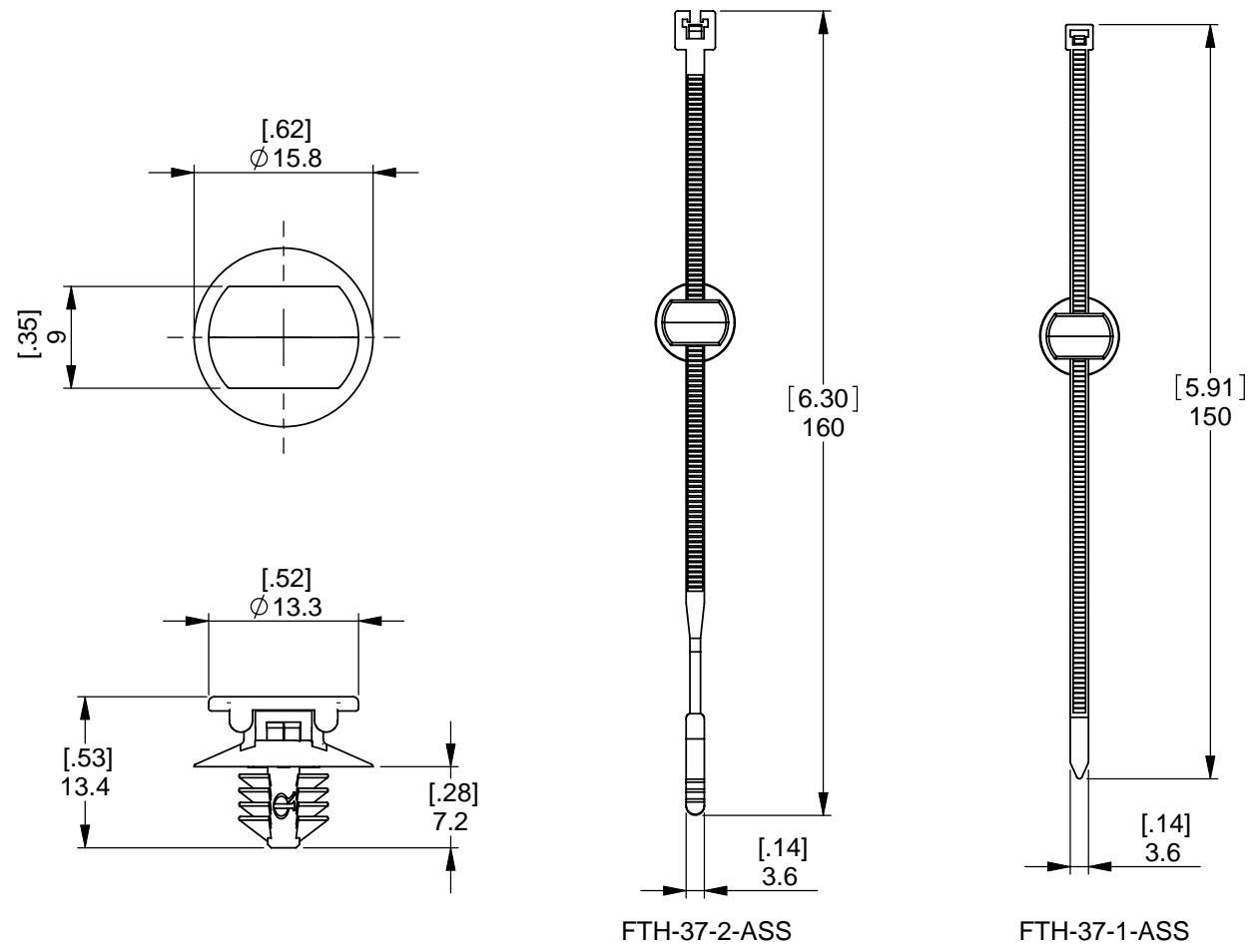

### ALTERNATE UNITS FOR REFERENCE ONLY

INFORMATION CONTAINED IN THIS DOCUMENT IS CONFIDENTIAL TO RICHCO INTERNATIONAL Co. Ltd. AND MAY NOT BE DISCLOSED OR REPRODUCED IN WHOLE OR PART WITHOUT THEIR WRITTEN CONSENT.

**Richco**  
 METRIC PRIMARY UNITS:mm  
 IMPERIAL SECONDARY UNITS:[inches]  
 GENERAL TOLERANCES ±0.25 [0.010]  
 UNLESS OTHERWISE STATED  
 1 DECIMAL PLACE ±  
 2 DECIMAL PLACES ±  
 ANGULAR ±1°

THIRD ANGLE

MATERIAL: <b>NYLON 6/6 UL94 V-2 (RMS-01)</b>		COLOUR: <b>BLACK</b>	
DESCRIPTION: <b>FIR TREE CABLE TIE HOLDER</b>		PART No: <b>SEE TABLE</b>	
DRG No: <b>07-124</b>	NPR No: <b>2006-212</b>	Mass:(g) <b>0.35</b>	SHEET SIZE <b>A4</b>
DRN <b>MT</b>	DATE <b>23/04/08</b>	CHKD <b>BO</b>	DATE <b>21/05/08</b>
SCALE <b>NTS</b>		SHEET No. <b>1 OF 1</b>	

PART NUMBER	MIN LOOP TENSILE STRENGTH (kg)	'L' LENGTH REF	MAX BUNDLE Ø	PANEL HOLE Ø	PANEL THICKNESS	COLOUR AND MATERIAL	
						CABLE TIE	CABLE TIE HOLDER
FTH-37-01BK	—	—	—	6.5-7 [.26-.28]	.8-3 [.03-.12]	—	NYLON 6/6 RMS-01, BLACK
FTH-37-1-ASS	18	150 [5.91]	39 [1.54]			NYLON 6/6 RMS-01, BLACK	NYLON 6/6 RMS-47, BLACK
FTH-37-2-ASS	13	160 [6.30]	38 [1.50]			UVB NYLON 6/6 RMS-221, BLACK	NYLON 6/6 RMS-47, BLACK

OTHER COLOURS AND MATERIALS AVAILABLE BY SPECIAL ORDER

# Mouser Electronics

Authorized Distributor

Click to View Pricing, Inventory, Delivery & Lifecycle Information:

[Essentra:](#)

[FTH-37-01BK](#)