

NOTES :

HOLE SIZE : 7.85 / 8

PANEL THICKNESS RANGE : 0.5 / 3.55

SCREW SIZE : #8-#10

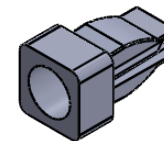
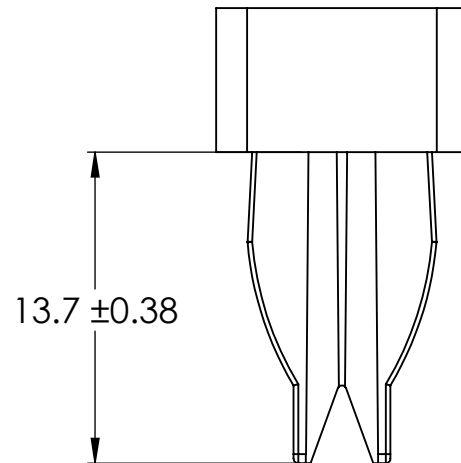
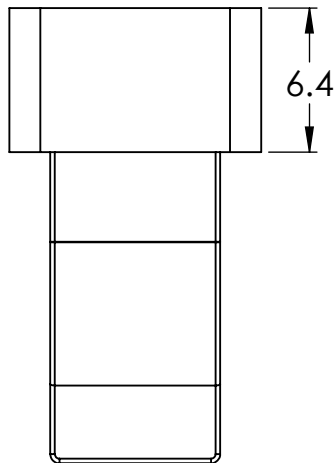

1:1

UNLESS OTHERWISE STATED

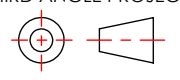
| ALL DIMENSIONS IN mm | DO NOT SCALE | | | | | | | | | | | | | | | | | | | | | | | | | | | | | | | | | | | | |
|--|-------------------------|-------|--------|--------|--------|------|-------|-------|--------|------|-------|-------|--------|------|-------|-------|---------|------|-------|-------|----------|------|-------|-------|----------|------|-------|-------|----------|------|-------|-------|------|------|-------|-------|--|
| LINEAR TOLERANCE | THIRD ANGLE PROJECTION | | | | | | | | | | | | | | | | | | | | | | | | | | | | | | | | | | | | |
| <table border="1"> <thead> <tr> <th>SIZE</th> <th>(0)</th> <th>(0.0)</th> <th>(0.00)</th> </tr> </thead> <tbody> <tr> <td>0-10mm</td> <td>±0.5</td> <td>±0.15</td> <td>±0.10</td> </tr> <tr> <td>>10-30</td> <td>±0.5</td> <td>±0.20</td> <td>±0.15</td> </tr> <tr> <td>>30-50</td> <td>±0.5</td> <td>±0.30</td> <td>±0.20</td> </tr> <tr> <td>>50-100</td> <td>±0.8</td> <td>±0.50</td> <td>±0.25</td> </tr> <tr> <td>>100-200</td> <td>±1.5</td> <td>±0.80</td> <td>±0.40</td> </tr> <tr> <td>>200-300</td> <td>±2.0</td> <td>±1.20</td> <td>±0.80</td> </tr> <tr> <td>>300-500</td> <td>±3.0</td> <td>±2.00</td> <td>±1.00</td> </tr> <tr> <td>>500</td> <td>±5.0</td> <td>±3.00</td> <td>±1.50</td> </tr> </tbody> </table> | SIZE | (0) | (0.0) | (0.00) | 0-10mm | ±0.5 | ±0.15 | ±0.10 | >10-30 | ±0.5 | ±0.20 | ±0.15 | >30-50 | ±0.5 | ±0.30 | ±0.20 | >50-100 | ±0.8 | ±0.50 | ±0.25 | >100-200 | ±1.5 | ±0.80 | ±0.40 | >200-300 | ±2.0 | ±1.20 | ±0.80 | >300-500 | ±3.0 | ±2.00 | ±1.00 | >500 | ±5.0 | ±3.00 | ±1.50 |  |
| SIZE | (0) | (0.0) | (0.00) | | | | | | | | | | | | | | | | | | | | | | | | | | | | | | | | | | |
| 0-10mm | ±0.5 | ±0.15 | ±0.10 | | | | | | | | | | | | | | | | | | | | | | | | | | | | | | | | | | |
| >10-30 | ±0.5 | ±0.20 | ±0.15 | | | | | | | | | | | | | | | | | | | | | | | | | | | | | | | | | | |
| >30-50 | ±0.5 | ±0.30 | ±0.20 | | | | | | | | | | | | | | | | | | | | | | | | | | | | | | | | | | |
| >50-100 | ±0.8 | ±0.50 | ±0.25 | | | | | | | | | | | | | | | | | | | | | | | | | | | | | | | | | | |
| >100-200 | ±1.5 | ±0.80 | ±0.40 | | | | | | | | | | | | | | | | | | | | | | | | | | | | | | | | | | |
| >200-300 | ±2.0 | ±1.20 | ±0.80 | | | | | | | | | | | | | | | | | | | | | | | | | | | | | | | | | | |
| >300-500 | ±3.0 | ±2.00 | ±1.00 | | | | | | | | | | | | | | | | | | | | | | | | | | | | | | | | | | |
| >500 | ±5.0 | ±3.00 | ±1.50 | | | | | | | | | | | | | | | | | | | | | | | | | | | | | | | | | | |
| ORG. SCALE: 3:1 | CREATE DATE: 11/12/2018 | | | | | | | | | | | | | | | | | | | | | | | | | | | | | | | | | | | | |

| |
|-------------------------------------|
| MATERIAL: PA 66 |
| Part ID: 1456147 Project: P160230-1 |

| |
|--|
| TITLE: SQ CLOSED SCREW GROMMET NUT H6.35 |
|--|

| | |
|---------------------|--------------|
| DWG. No. 60SGC00008 | SHEET 1 of 1 |
| | ISSUE 1 |

APPROVED - UNCONTROLLED

Mouser Electronics

Authorized Distributor

Click to View Pricing, Inventory, Delivery & Lifecycle Information:

[Essentra:](#)

[60SGC00008](#)