

DS1100SLPE-3

1100 Watts

Distributed Power

Total Power: 1100 Watts
Input Voltage: 90 to 264 Vac
of Outputs: Main and Standby



Special Features

- 1100 W output power
- High-power and short form factor
- 1U power supply
- High-density design: 26 W/in³
- Active Power Factor Correction
- EN61000-3-2 harmonic compliance
- 80plus Platinum Efficiency
- Inrush current control
- N+1 or N+N Redundant
- Hot-pluggable
- Active current sharing
- Full digital control
- PMBus compliant
- Accurate input power reporting
- Compatible with Artesyn's Universal PMBus GUI
- Reverse airflow option
- Two-year warranty

Safety

UL/cUL 62368-1 (UL Recognized)
DEMKO+ CB Report EN62368-1
CE Mark
China CCC
BSMI

Product Descriptions

DS1100SLPE-3 series power supply accepts a wide range 90-264 Vac input and provides a main 12 V output and a 3.3 V standby output, rated at 1,100 watts. It is an 80 Plus Platinum supply with a high peak efficiency of 94%. Housed in an industry standard 1U x 2.1 inch rack-mounting package, the power supply is ideal for space-constrained applications. This series comes in two airflow versions - dc-connector to ac-connector and vice versa.

The main 12 V output can deliver up to 90 A and stay within regulation down to zero load, making it perfect for feeding downstream DC-DC converters in systems that use distributed power architectures (DPA). Active current sharing enables multiple supplies to be paralleled for very high current applications without need of additional components. The power supply is hot pluggable and ideal for fault tolerant, N+1 and N+N redundant applications.

This digitally-controlled power supply is PMBus™ compliant. A built-in I2C serial interface allows set-up, monitoring and control to be performed using Artesyn Embedded Technologies' universal PMBus graphical user interface.

Model Numbers

Standard	Output Voltage	Minimum Load	Maximum Load	Standby Supply	Air Flow Direction
DS1100SLPE-3	12.0Vdc	0A	90.0A	3.3Vdc@3A	Forward (DC Connector to Red Handle)
DS1100SLPE-3 -001	12.0Vdc	0A	90.0A	3.3Vdc@3A	Reverse ¹ (Blue Handle to DC Connector)

Note 1 - Derating may apply, see Table 12.

Options

None

Electrical Specifications

Absolute Maximum Ratings

Stress in excess of those listed in the “Absolute Maximum Ratings” may cause permanent damage to the power supply. These are stress ratings only and functional operation of the unit is not implied at these or any other conditions above those given in the operational sections of this TRN. Exposure to any absolute maximum rated condition for extended periods may adversely affect the power supply’s reliability.

Table 1. Absolute Maximum Ratings:

Parameter	Model	Symbol	Min	Typ	Max	Unit
Input Voltage AC continuous operation	All models	$V_{IN,AC}$	90	-	264	Vac
Maximum Output Power (Main + Standby)	All models	$P_{O,max}$	-	-	1100	W
Isolation Voltage Input to outputs Input to safety ground	All models All models		- -	- -	4243 2951	Vdc Vdc
Ambient Operating Temperature	DS1100SLPE-3 DS1100SLPE-3-001	T_A	-5 -5	- -	+65 ¹ +55 ¹	°C
Storage Temperature	All models	T_{STG}	-40	-	+85	°C
Humidity (non-condensing) Operating Non-operating	All models All models		5 5	- -	90 95	% %
Altitude Operating Non-operating	All models		- -	- -	10,000 50,000	feet feet
MTBF ²	All models		500	-	-	KHr

Note 1 - DS1100SLPE-3: 1100W from -5 to 50°C, withstand operation up to 65°C at 660W output power without damage.

DS1100SLPE-3-001: 1100W from -5 to 45°C, withstand operation up to 55°C at 660W output power without damage.

Note 2 - Telcordia Issue 3 at full load, 40°C

Input Specifications

Table 2. Input Specifications:

Parameter	Conditions	Symbol	Min	Typ	Max	Unit	
Operating Input Voltage, AC	All	$V_{IN,AC}$	90	115/230	264	Vac	
Input AC Frequency	All	$f_{IN,AC}$	47	50/60	63	Hz	
Maximum Input Current ($I_O = I_{O,max}$, $I_{SB} = I_{SB,max}$)	$V_{IN,AC} = 90Vac$	$I_{IN,max}$	-	-	14.5	A	
No Load Input Power ($V_O = On$, $I_O = 0A$, $I_{SB} = 0A$)	All	$P_{IN,no-load}$	-	-	15	W	
No Load Input Current ($V_O = On$, $I_O = 0A$, $I_{SB} = 0A$)	All	$I_{IN,no-load}$	-	-	200	mA	
Harmonic Line Currents	All	THD	Per EN61000-3-2				
Power Factor	20% load and above	PF	0.9	-	-		
Startup Surge Current (Inrush)	Cold-start Hot-start	$V_{IN,AC} = 264Vac$	$I_{IN,surge}$	-	-	55	A
				-	-	35	
Input Fuse	Internal, 5x20mm, Quick Acting 16A, 250V		-	16	-	A	
Leakage Current to Earth Ground	$V_{IN,AC} = 264Vac$ $f_{IN,AC} = 50/60Hz$		-	-	1.75	mA	
Operating Efficiency ¹	$V_{IN,AC} = 230Vac$ $I_O = 10\% I_{O,max}$ $I_O = 20\% I_{O,max}$ $I_O = 50\% I_{O,max}$ $I_O = 100\% I_{O,max}$	η	80	-	-	%	
			90	-	-	%	
			94	-	-	%	
			91	-	-	%	
System Stability	Phase Margin Gain Margin		45	-	-	\emptyset	
			-	-6	-	dB	

Note 1 - DS1100SLPE-3 is certified for 80plus Platinum Efficiency level at 230Vac. The loading conditions are defined according to CSCI criteria.

Output Specifications

Table 3. Output Specifications:

Parameter	Conditions	Symbol	Min	Typ	Max	Unit
Factory Set Voltage	All	$\%V_O$	-1	-	+1	%
		$\%V_{SB}$	-1	-	+1	
Output Regulation	Inclusive of set-point, temperature change, warm-up drift	V_O	11.4	12.0	12.6	Vdc
		V_{SB}	3.14	3.3	3.46	
Output Ripple, pk-pk	Measure with a 0.1uF ceramic capacitor in parallel with a 10uF tantalum capacitor, 0 to 20MHz bandwidth. A resistor load is recommended.	V_O	-	-	180	mV _{PK-PK}
		V_{SB}	-	-	80	
Output Current ¹	All	I_O	5.0	-	90.0	A
		I_{SB}	0.0	-	3.0	
V_O Current Share Accuracy	25% to 100% $I_{O,max}$		-5.625	-	5.625	A
Minimum Load for Current Sharing	All		7	-	-	$\%I_{O,max}$
Number of Parallel Units	Main Output "ISHARE" connected		-	-	6	Unit
Load Capacitance	Start up	V_O	500	-	11,000	uF
		V_{SB}	20	-	1000	uF
V_O Dynamic Load Response Peak Deviation ²	50% load change, slew rate = 1A/uS	$\pm\%V_O$	-5	-	5	%
V_O Dynamic Load Response Setting Time	50% load change, slew rate = 1A/uS	T_S	-	500	-	uSec
V_O Long Term Stability Max change over 24 hours	After thermal equilibrium (30 mins) $V_{IN,AC} = 100/200V_{ac}$	$\pm\%V_O$	-0.5	-	0.5	%

Note 1 - No load operation will not cause any damage to the power supply. Overshoot/undershoot limits do not apply during turn-on/turn-off at no load condition.

Note 2 - Minimum allowable output capacitance of 500uF during this test.

System Timing Specifications

Table 4. System Timing Specifications:

Label	Parameter	Min	Typ	Max	Unit
T1	Delay from AC being applied to V_{SB} being within regulation	-	-	2500	mSec
T2	Delay from Standby output to main output voltage being within regulation.	-	-	1000	mSec
T3	Delay from AC being applied to main output voltages being within regulation.	-	-	3000	mSec
T4	Delay from output voltages within regulation limits to PWOK asserted.	100	-	1000	mSec
T5	Delay from loss of AC to deassertion of PWOK	5	-	-	mSec
T6	Delay from loss of AC to main output falling out of regulation	16	-	-	mSec
T7	Delay from loss of AC to deassertion of ACOK	-	-	20	mSec
T8 ¹	Delay from loss of AC to Standby output falling out of regulation.	25	-	-	mSec
T9	Delay from deassertion of PWOK to output voltages falling out of regulation.	1	-	700	mSec
T10	Delay from PS_ON_L assertion to output voltages being within regulation.	-	-	400	mSec

Note 1 - T8 is measured with standby output loaded at 1A.

System Timing Specifications

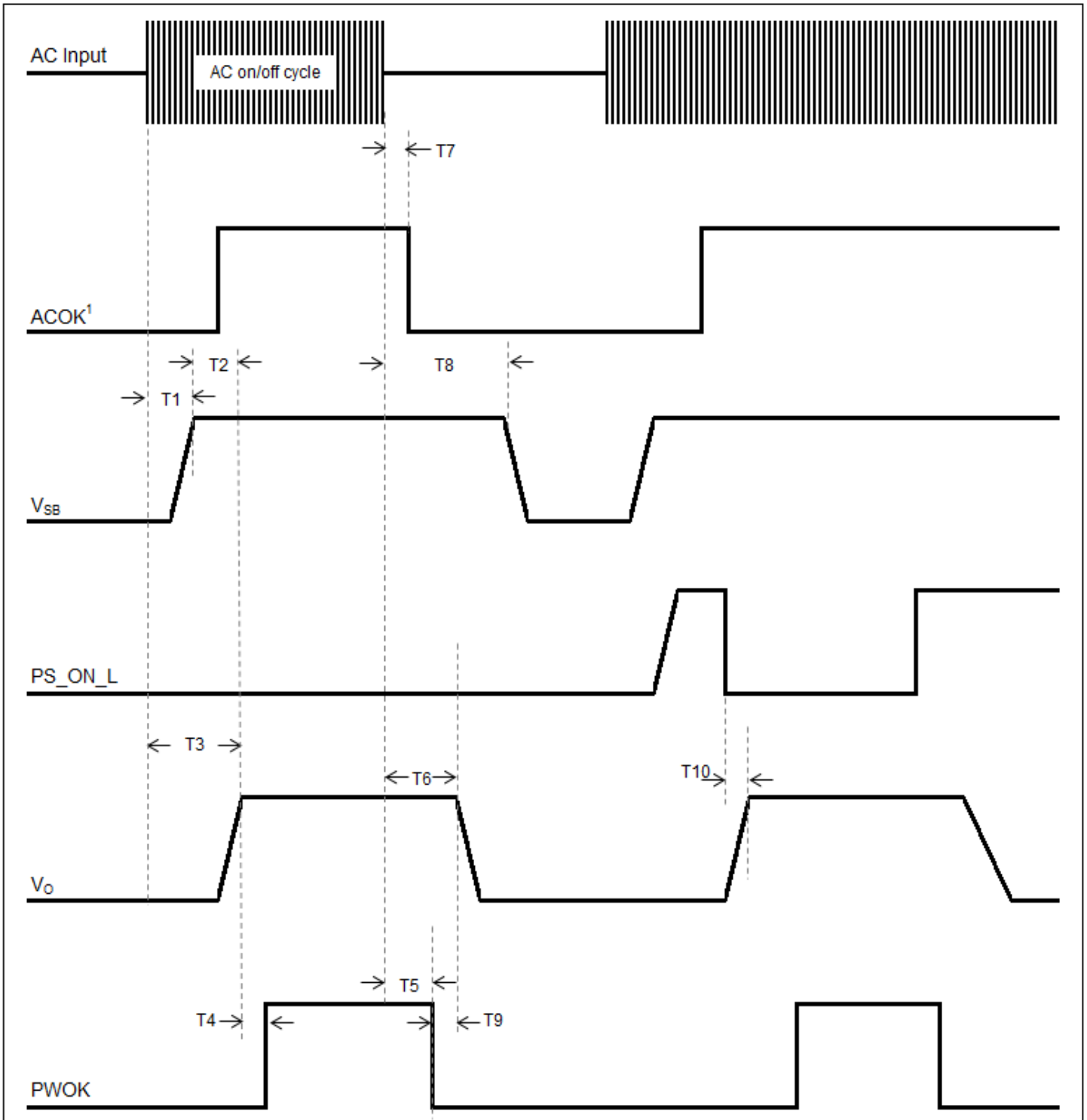

Note 1 - ACOK can assert earlier than V_{SB}.

DS1100SLPE-3 Performance Curves

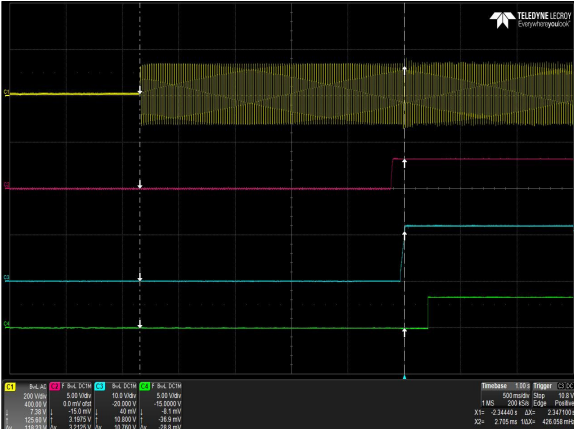

Figure 1: DS1100SLPE-3 Turn-on delay via AC mains - Vin = 90Vac
Full Load: $I_o = 90.0A$, $I_{SB} = 3A$
Ch 1: AC Mains Ch 2: V_{SB} Ch 3: V_o Ch 4: PWOK

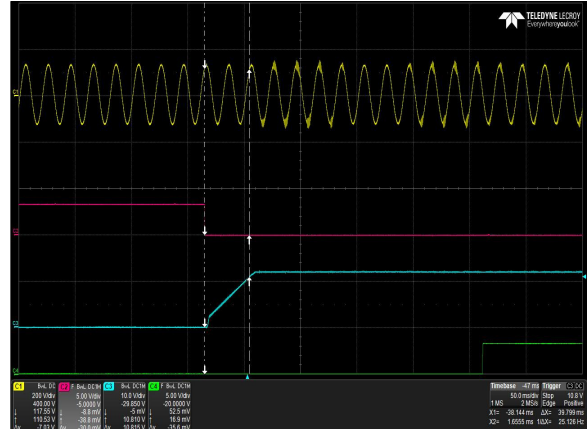

Figure 2: DS1100SLPE-3 Turn-on delay via PS_ON_L - Vin = 90Vac
Full Load: $I_o = 90.0A$, $I_{SB} = 3A$
Ch 1: AC Mains Ch 2: PS_ON_L Ch 3: V_o Ch 4: PWOK

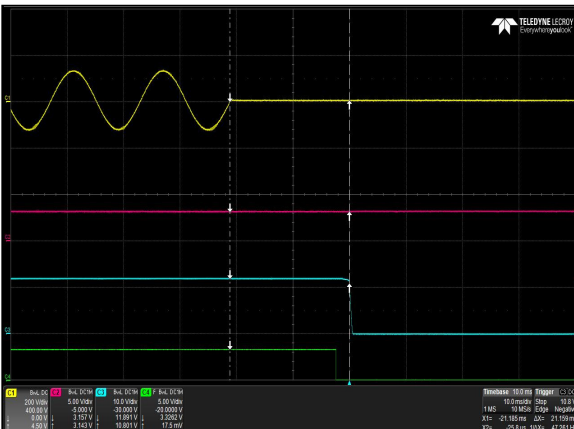

Figure 3: DS1100SLPE-3 Hold-up Time - Vin = 90Vac / 63Hz / 0°
Full Load: $I_o = 90.0A$, $I_{SB} = 3A$
Ch 1: AC Mains Ch 2: V_{SB} Ch 3: V_o Ch 4: PWOK

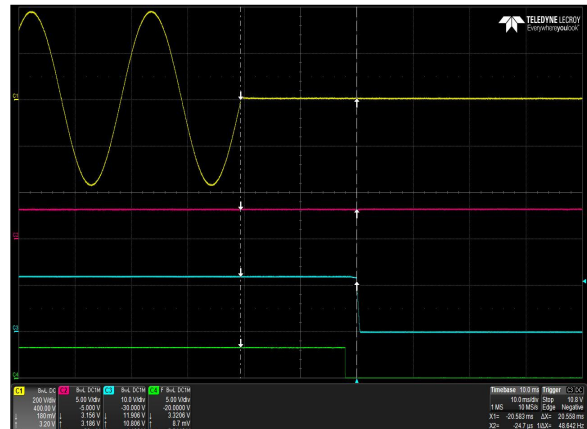

Figure 4: DS1100SLPE-3 Hold-up Time - Vin = 264Vac / 47Hz / 0°
Full Load: $I_o = 90.0A$, $I_{SB} = 3A$
Ch 1: AC Mains Ch 2: V_{SB} Ch 3: V_o Ch 4: PWOK

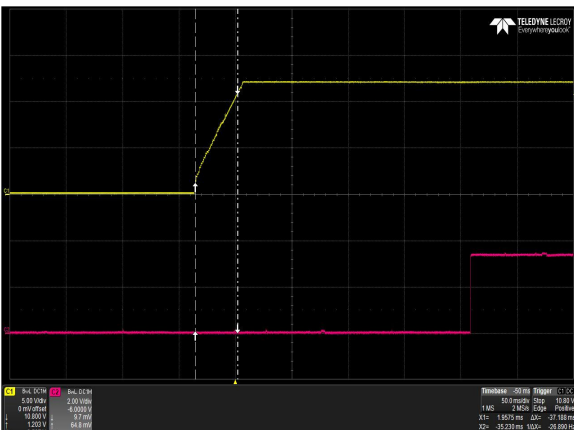

Figure 5: DS1100SLPE-3 Output Voltage Startup - Vin = 115Vac
Full Load: $I_o = 0A$
Ch 1: V_o Ch 2: PWOK

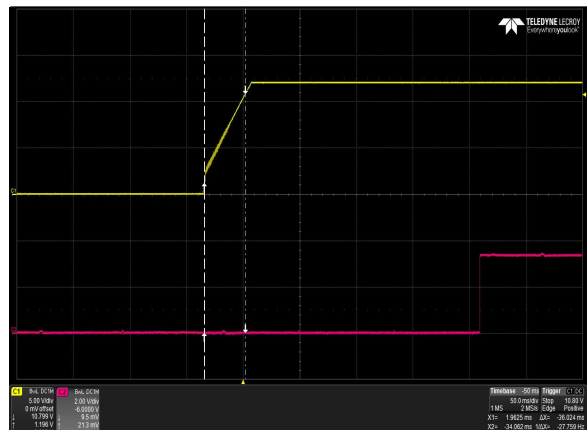

Figure 6: DS1100SLPE-3 Output Voltage Startup - Vin = 115Vac
Full Load: $I_o = 45A$
Ch 1: V_o Ch 2: PWOK

DS1100SLPE-3 Performance Curves

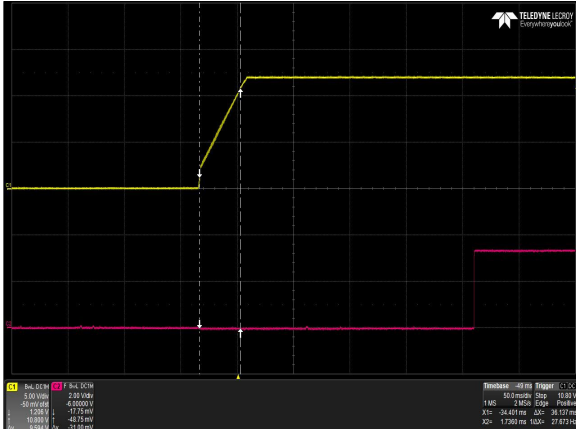

Figure 7: DS1100SLPE-3 Output Voltage Startup - $V_{in} = 115V_{ac}$
Full Load: $I_o = 90.0A$
Ch 1: V_o Ch 2: PWOK

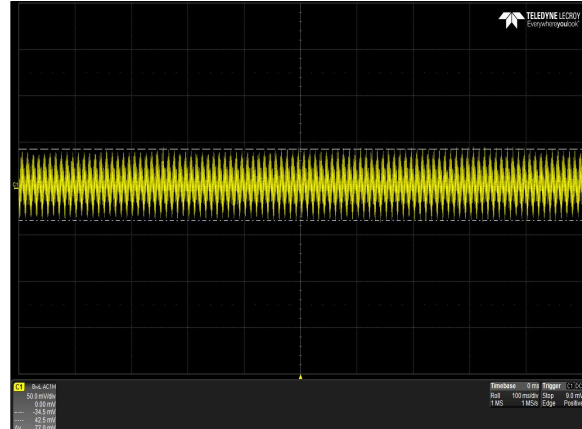

Figure 8: DS1100SLPE-3 Ripple and Noise Measurement - $V_{in} = 115V_{ac}$
Full Load: $I_o = 90.0A$, $I_{SB} = 3A$
Ch 1: V_o

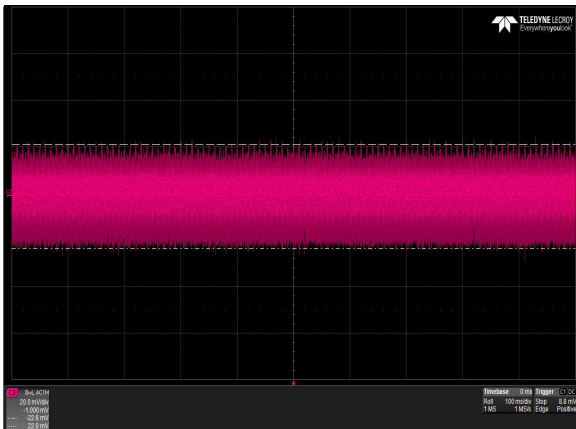

Figure 9: DS1100SLPE-3 Ripple and Noise Measurement - $V_{in} = 115V_{ac}$
Full Load: $I_o = 90.0A$, $I_{SB} = 3A$
Ch 2: V_{SB}

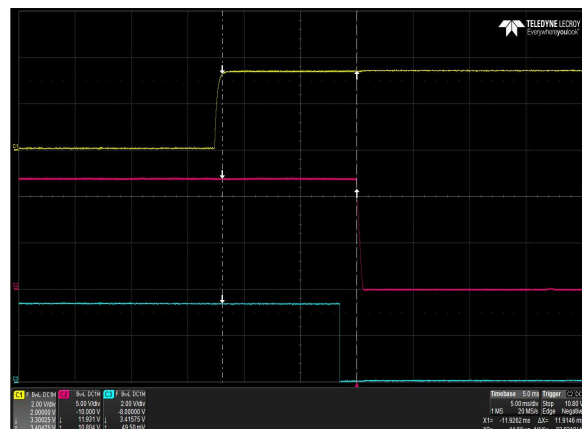

Figure 10: DS1100SLPE-3 Turn Off Characteristic via PS_ON_L
Full Load: $I_o = 90.0A$
Ch 1: PS_ON_L Ch 2: V_o Ch 3: PWOK

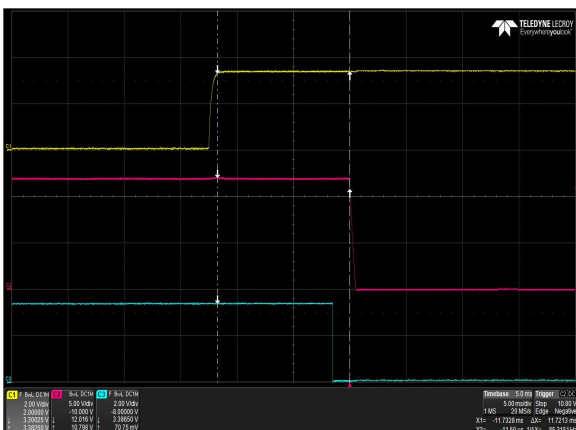

Figure 11: DS1100SLPE-3 Turn Off Characteristic via PS_KILL_L
Full Load: $I_o = 90.0A$
Ch 1: PS_KILL_L Ch 2: V_o Ch 3: PWOK

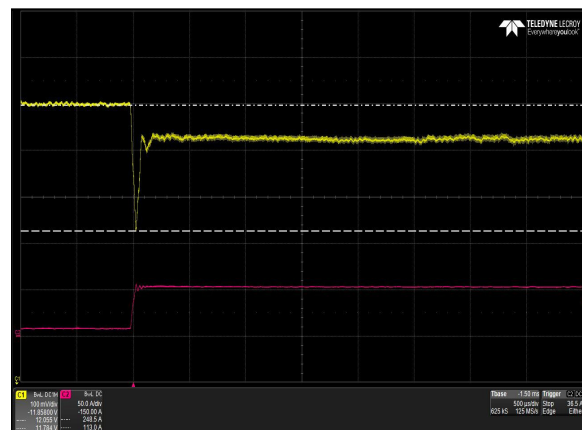

Figure 12: DS1100SLPE-3 Transient Response - V_o Deviation (low to high)
10% to 60% load change, 1A/uS slew rate, $V_{IN} = 230V_{ac}$
Ch 1: V_o Ch 2: I_o Output capacitance = 500uF

DS1100SLPE-3 Performance Curves

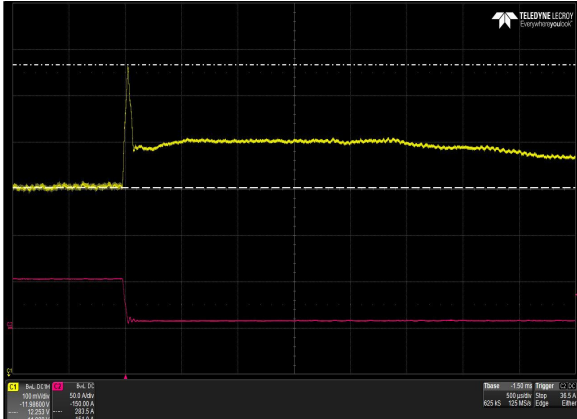

Figure 13: DS1100SLPE-3 Transient Response - Vo Deviation (high to low)
60% to 10% load change, 1A/uS slew rate, $V_{IN} = 230\text{Vac}$
Ch 1: V_o Ch 2: I_o Output capacitance = 500uF

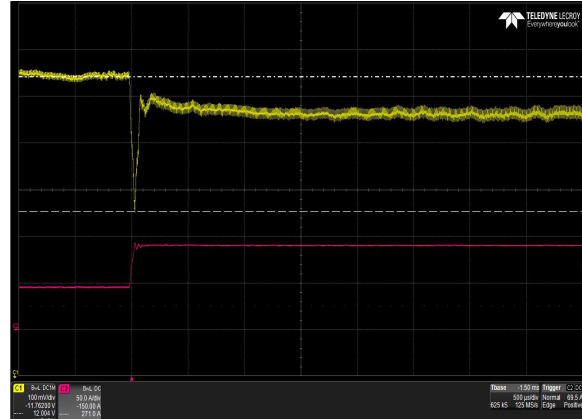

Figure 14: DS1100SLPE-3 Transient Response - Vo Deviation (low to high)
50% to 100% load change, 1A/uS slew rate, $V_{IN} = 230\text{Vac}$
Ch 1: V_o Ch 2: I_o Output capacitance = 500uF

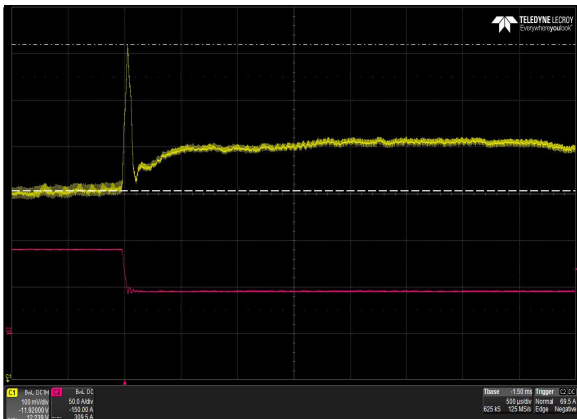

Figure 15: DS1100SLPE-3 Transient Response - Vo Deviation (high to low)
100% to 50% load change, 1A/uS slew rate, $V_{IN} = 230\text{Vac}$
Ch 1: V_o Ch 2: I_o Output capacitance = 500uF

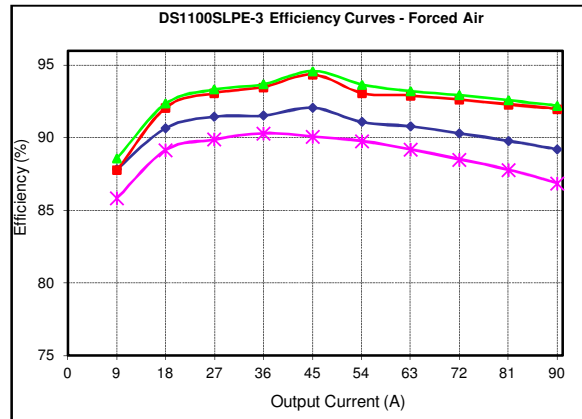

Figure 16: DS1100SLPE-3 Efficiency Curves @ 25 degC
 * 90 Vac * 115 Vac * 230 Vac * 264 Vac
 Loading: $I_o = 10\% I_{o,max}$ increment to 90.0A

Protection Function Specification

Input Fusing

DS1100SLPE-3 series power supply is equipped with an internal non user replaceable 16A Fast Acting 250Vac fuse to IEC 127 for fault protection in the L line input.

Over Voltage / Under Voltage Protection (OVP / UVP)

DS1100SLPE-3 series power supply provides latch mode over and under voltage protection as defined by the output under voltage and output over voltage parameters for each output. When the OVP circuit is activated (main output and standby), the power supply must latch off requiring PSON or the input power to be recycled manually to reset the power supply after the fault has been removed.

Parameter	Min	Nom	Max	Unit
V _O Output Over Voltage	13.2	/	14.5	Vdc
V _{SB} Output Over Voltage	3.6	/	3.9	Vdc

The power supply will shutdown within 20mSec if the output voltage drops below 20% of the nominal rating for more than 2.5mSec. The power supply will attempt to auto-restart once every 3 seconds.

The under-voltage protection can be disabled during start-up and shutdown transitions. A failure on the reference used for regulating the output voltage should not cause the power supply to lose its ability to protect against over-voltage.

Parameter	Min	Nom	Max	Unit
V _O Output Under Voltage	9.6	/	/	V
V _{SB} Output Under Voltage	/	/	/	V

Over Current Protection (OCP)

DS1100SLPE-3 series power supply includes internal current limit circuitry to prevent damage in the event of overload or short circuit. The Main output will be internally protected against output overload or short circuit applied to its output. A fault in the main output will not cause the standby output to shut down. No damage will result to the supply as the result of either short term or long term overloads of the output.

The standby output will have an OCP limit from 110%-150% and will auto-recover when the overload is removed. A fault in the standby output will shutdown other outputs and will auto-recover as well. When the overload on the standby is removed. An OCP fault on the main output will not cause the standby output to fail. The over-current thresholds must be measured under all operating line, load, and temperature conditions.

Parameter	Min	Nom	Max	Unit
V _O Output Over Current	107	/	130	%I _{O,max}
V _{SB} Output Over Current	110	/	150	%I _{SB,max}

Short Circuit Protection (SCP)

DS1100SLPE-3 series power supply protects against a short circuit, which is defined as an impedance of 0.1 ohms or less, applied to any output during start-up or while running will not cause any damage to the power supply (connectors, components, PCB traces, etc.).

When the standby output is shorted, the output will go into “hiccup mode.” When the standby output attempts to restart, the maximum peak current from the output must be less than 10A. The maximum average current, taking into account the “hiccup” duty cycle, must not exceed rated DC output current of the standby.

Over Temperature Protection (OTP)

DS1100SLPE-3 series power supply is internally protected against over temperature conditions. When the OTP limit is reached, all outputs, except standby, will shut down and will remain off until the over temperature condition no longer exists.

A suitable hysteresis point between the OTP threshold and the recovery point will be set to ensure there is no frequent on-off cycling of the outputs. The temperature recovery point will be set well with-in the operating temperature range. Upon reaching the temperature recovery point, all outputs will auto-recover.

Any OTP fault will be reported in the PMBus status flag, without discriminating on which OTP sensing circuit was triggered.

Mechanical Specifications

Mechanical Outlines

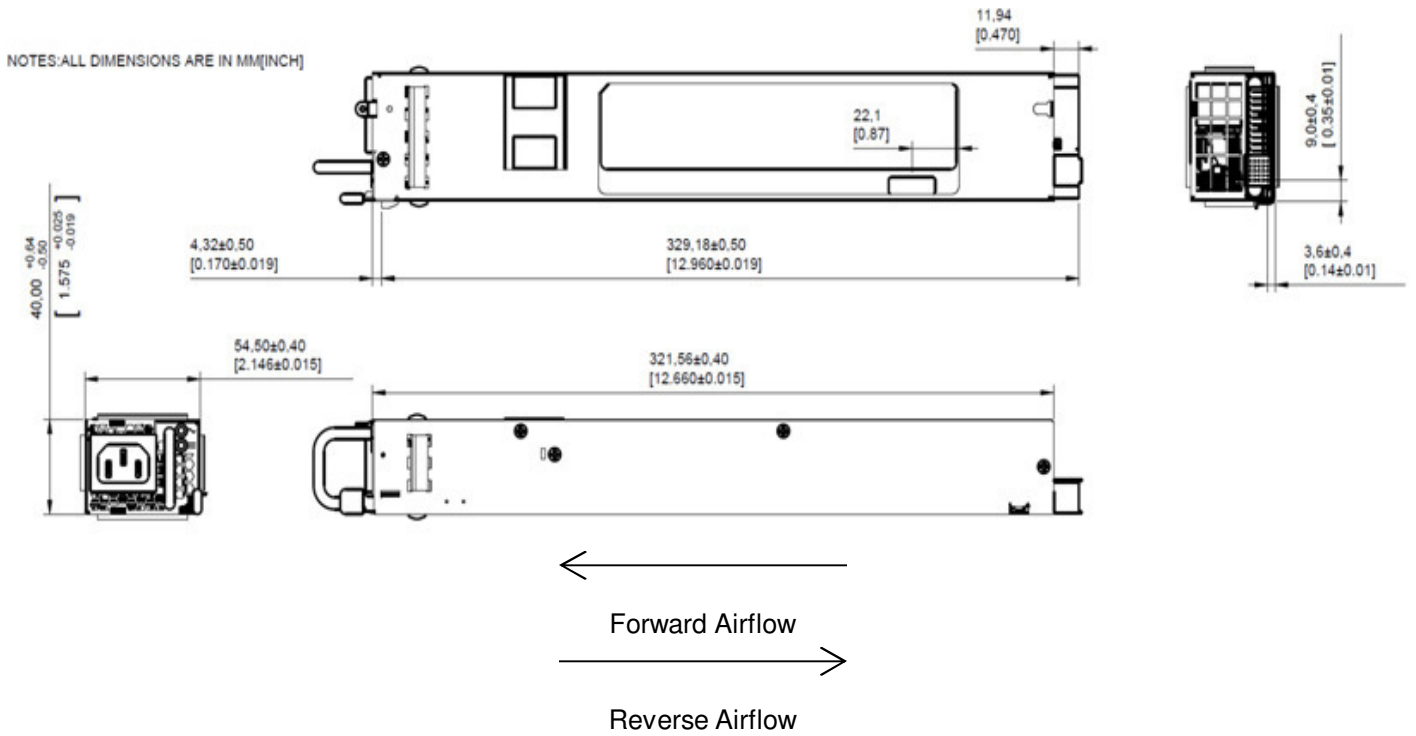

Connector Definitions

AC Input Connector

- Pin 1 - L
- Pin 2 - N
- Pin 3 - Earth Ground

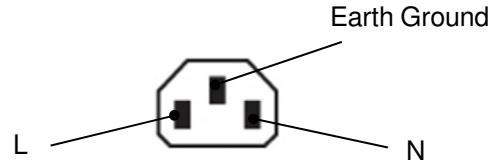

Output Connector - Power Blades

- P1-P5 - +12V Return
- P6-P10 - 12V

Output Connector - Control Signals

- A1 - 3.3V_{SB}
- B1 - 3.3V_{SB}
- C1 - 3.3V_{SB}
- D1 - 3.3V_{SB}
- E1 - 3.3V_{SB}
- A2 - SGND
- B2 - SGND
- C2 - Reserved
- D2 - Reserved
- E2 - Reserved
- A3 - A2
- B3 - A0
- C3 - SDA
- D3 - - Remote Sense
- E3 - +Remote Sense
- A4 - SCL
- B4 - PSON_L
- C4 - PS_INTERRUPT_L
- D4 - A1
- E4 - AC_OK
- A5 - PSKILL_L
- B5 - ISHARE
- C5 - PWOK
- D5 - Reserved
- E5 - PS_PRESENT_L

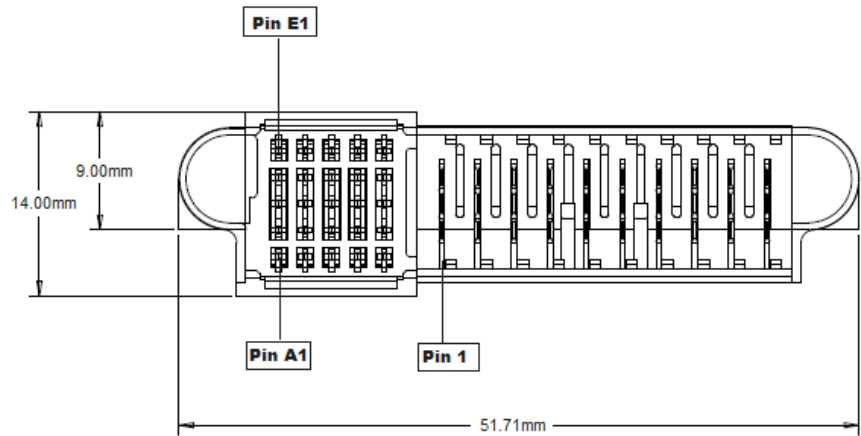

Power Supply Output Card Edge

Power / Signal Mating Connectors and Pin Types

Table 5. Mating Connectors for DS1100SLPE-3 series

Reference	On Power Supply	Mating Connector or Equivalent
AC Input Connector	IEC320-C14	IEC320-C13
Output Connector	TEI 1926736-3	TEI 2-1926739-5, 1892787-6 or equivalent

LED indicator Definition

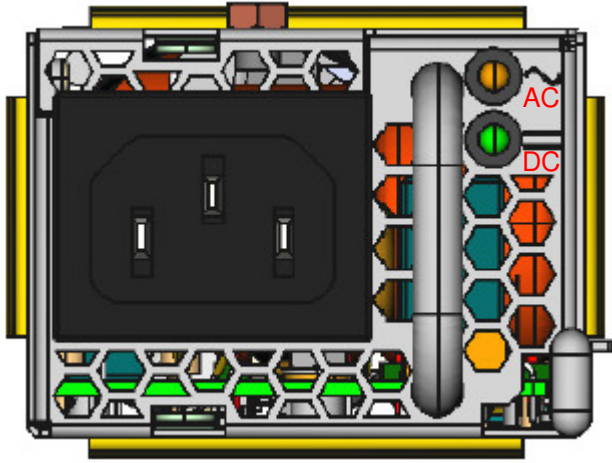

There are two LEDs on the power supply chassis at the end opposite to the DC output connector. Output LED indicated will be bi-color (green/amber). The status LED conditions is shown on the below table.

Table 6. LED status

Conditions	INPUT LED	OUTPUT LED (bi-color)
COLOR	GREEN	AMBER/GREEN
NO AC INPUT TO PSU	OFF	OFF
AC PRESENT, STBY ON, MAIN OUTPUT OFF	ON	Blinking Amber, at least 1Hz
MAIN OUTPUT ON	ON	ON, GREEN
POWER SUPPLY WARNING (Hi-temp)	ON	Blinking Amber/Green, at 1:1, 1Hz On
POWER SUPPLY WARNING (Slow fan)	ON	Blinking Amber/Green, at 1:1, 1Hz On
POWER SUPPLY FAILURE (OVP, OTP, FAN FAULT)	ON	ON, Amber

Weight

The maximum weight of DS1100SLPE-3 series power supply is 2.43 lbs / 1100 g.

Environmental Specifications

EMC Immunity

DS1100SLPE-3 series power supply meets the following EMC immunity specifications:

Table 7. Environmental Specifications:

Document	Description
FCC 47CFR 15 Subpart B / CISPR 22/ EN55022/EN300386/GR1089, Class A	Conducted and Radiated EMI Limits, 6dB Margin
EN61000-3-2	Harmonic Currents
EN61000-3-3	Voltage Fluctuations
IEC/EN 61000-4-2	Electromagnetic Compatibility (EMC) - Testing and measurement techniques - Electrostatic discharge immunity test. 15KV air, 8KV contact discharge, performance Criteria B
IEC/EN 61000-4-3	Electromagnetic Compatibility (EMC) - Testing and measurement techniques, Radiated, radio-frequency, electromagnetic field immunity test, Criteria A
IEC/EN 61000-4-4	Electromagnetic Compatibility (EMC) - Testing and measurement techniques, Electrical Fast Transient/Burst Immunity Test. +/-2KV for AC power port Criteria B, +/-0.5KV for DC ports, I/O and signal ports performance Criteria A
IEC/EN 61000-4-5	Electromagnetic Compatibility (EMC) - Testing and measurement techniques: 4KV common mode and 2KV differential mode for AC ports performance criteria B, 2KV common mode and 1KV differential mode for AC ports performance criteria A
IEC/EN 61000-4-6	Electromagnetic Compatibility (EMC) - Testing and measurement techniques - Immunity to conducted disturbances, induced by radio-frequency fields, performance criteria A
IEC/EN 61000-4-11	Electromagnetic Compatibility (EMC) - Testing and measurement techniques : Voltage Dips and Interruptions: >30% reduction for 500ms, Criteria C, >95% reduction at 60% load for 10ms, Criteria A, >95% reduction for 500mS, Criteria C
IEC/EN 61000-4-12	Electromagnetic Compatibility (EMC) - Testing and measurement techniques - Ring wave immunity: 4KV common mode and 2KV differential mode for AC ports performance criteria A, 2KV common mode and 1KV differential mode for AC ports performance criteria A
EN55022	Information Technology Equipment-Immunity Characteristics, Limits and Method of Measurements

Environmental Specifications

AC Input Sag and Surge

DS1100SLPE-3 series power supply meets the performance criteria requirements as per Table 8 and Table 9 when subjected to AC line sag and surge conditions. The power supply meets the performance criteria requirements at 60% load. When the power supply is loaded more than 60% or the duration is more than 1/2 cycle, the power supply may regulate between 11.3V to 12.7V.

Table 8. AC Line Surge:

Duration	Surge	Operating AC voltage	Line Frequency	Performance Criteria
Continuous	10%	140/240Vac	50/60 Hz	No loss of function or performance
0 to 1/2 AC cycle	30%	115/230Vac	50/60 Hz	No loss of function or performance

Table 9. AC Line Sag:

Duration	Sag	Operating AC voltage	Line Frequency	Performance Criteria
Continuous	10% of operating	100/200Vac	50/60 Hz	No loss of function or performance
0 to 1/2 AC cycle	60% of operating	100/200Vac	50/60 Hz	No loss of function or performance
0 to 1/2 AC cycle	100% of operating	100/200Vac	50/60 Hz	Loss of function or performance acceptable, self-recoverable
0 to 1 AC cycle	100% of operating	100/200Vac	50/60 Hz	Loss of function or performance acceptable, self-recoverable
500ms	30% of operating	100/200Vac	50/60 Hz	Loss of function or performance acceptable, self-recoverable

Safety Certifications

DS1100SLPE-3 series power supply is intended for inclusion in other equipment and the installer must ensure that it is in compliance with all the requirements of the end application. This product is only for inclusion by professional installers within other equipment and must not be operated as a stand alone product.

Table 10. Safety Certifications for DS1100SLPE-3 series power supply

Document	File #	Description
UL 62368-1	E132002-A6043-UL X24	US and Canada Requirements
EN 62368-1	D-07663	European Requirements
IEC 62368-1	E132002-A6043-CB-1 DK-77742-UL	International Electrotechnical Commission
CHINA CCC Approval	2018010907124807	China Requirements
BSMI	CI33216160216399	Taiwan Requirements
CE Mark	819006	European Requirements

EMI Emissions

DS1100SLPE-3 series power supply complies with the Class A limits of EMI requirements of EN55022 (FCC Part 15) and CISPR 22 (EN55022) for emissions and relevant sections of EN61000 (IEC 61000) for immunity. The unit is enclosed inside a metal box, tested at 1100W using resistive load with cooling fan.

Conducted Emissions

The applicable standard for conducted emissions is EN55022 (FCC Part 15). Conducted noise can appear as both differential mode and common mode noise currents. Differential mode noise is measured between the two input lines, with the major components occurring at the supply fundamental switching frequency and its harmonics. Common mode noise, a contributor to both radiated emissions and input conducted emissions, is measured between the input lines and system ground and can be broadband in nature.

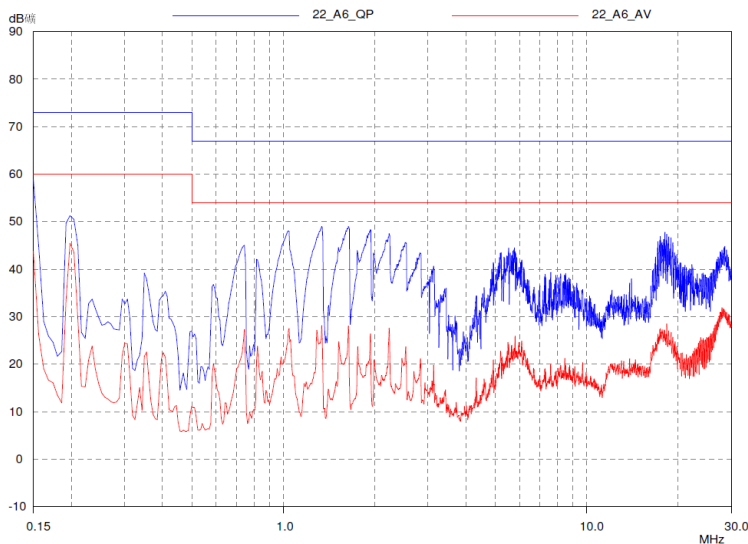

DS1100SLPE-3 series power supply has internal EMI filters to ensure the converters' conducted EMI levels comply with EN55022 (FCC Part 15) Class A and EN55022 (CISPR 22) Class A limits. The EMI measurements are performed with resistive loads at maximum rated loading.

Sample of EN55022 Conducted EMI Measurement at 230Vac input

Note: Blue Line refers to Artesyn Quasi Peak margin, which is 6dB below the CISPR international limit. Red Line refers to the Artesyn Average margin, which is 6dB below the CISPR international limit.

Table 11. Conducted EMI emission specifications of the DS1100SLPE-3 series power supply

Parameter	Model	Symbol	Min	Typ	Max	Unit
FCC Part 15, class A	All	Margin	-	-	6	dB
CISPR 22 (EN55022) class A	All	Margin	-	-	6	dB

Radiated Emissions

Unlike conducted EMI, radiated EMI performance in a system environment may differ drastically from that in a stand-alone power supply. It is thus recommended that radiated EMI is evaluated in a system environment. The applicable standard is EN55022 Class A (FCC Part 15). Testing AC-DC converters as a stand-alone component to the exact requirements of EN55022 can be difficult, because the standard calls for 1m leads to be attached to the input and outputs and aligned such as to maximize the disturbance. In such a set-up, it is possible to form a perfect dipole antenna that very few AC-DC converters could pass. However, the standard also states that an attempt should be made to maximize the disturbance consistent with the typical application by varying the configuration of the test sample.

Operating Temperature

DS1100SLPE-3 power supply can start and operate within stated specifications at an ambient temperature from -5°C to 55°C under all load conditions with internal fan. DS1100SLPE-3 series can provide derated output power 660W from 55°C up to 65°C ambient temperature max.

The DS1100SLPE-3-001 power supplies can start and operate within stated specifications at an ambient temperature from -5°C to 45°C under all load conditions with internal fan. DS1100SLPE-3-001 series can provide derated output power 660W from 45°C up to 55°C ambient temperature max.

Forced Air Cooling

DS1100SLPE-3 series power supply includes internal cooling fans as part of the power supply assembly to provide forced air-cooling to maintain and control temperature of devices and ambient temperature in the power supply to appropriate levels. The standard direction of airflow is from the DC connector end to the AC connector end of the power supply.

The cooling fan is a variable speed fan. In Standby mode power supply fan will operate at minimum speed to maintain component reliability at all load, line and ambient conditions. When 12V output is enabled, power supply fan will operate at minimum achievable fan speed. Power supply fan speed control algorithms will vary the speed so that the critical component temperatures do not exceed safe operating levels. Fans will be powered from voltage source inside the power supply and from system side voltage source.

The minimum airflow to cool the power supply is 9 CFM. The system backpressure may reduce the CFM through the power supply, so care must be taken to ensure that the minimum airflow is met while operating at 100% load.”

Power Derating

DS1100SLPE-3 & DS1100SLPE-3-001 total output power will be derated according to the table shown below.

Table 12. Power Derating

Model	Notes	Min	Max	Altitude	System Back Pressure
DS1100SLPE-3	1100W load	0 °C	55 °C	6000 ft	0.8” H ₂ O
	660W load	0 °C	55 °C	10000 ft	1.2” H ₂ O
	660W load	-5 °C	65 °C	6000 ft	1.2” H ₂ O
DS1100SLPE-3-001	1100W load	0 °C	45 °C	6000 ft	0.8” H ₂ O
	660W load	0 °C	45 °C	10,000 ft	1.2” H ₂ O
	660W load	-5 °C	55 °C	6,000 ft	1.2” H ₂ O

Storage and Shipping Temperature

DS1100SLPE-3 series power supply can be stored or shipped at temperatures between -40°C to +85°C.

Altitude

DS1100SLPE-3 power supply operates within specifications at altitudes up to 6000 feet above sea level (ambient temperature derated to 55°C at 10,000 feet).

DS1100SLPE-3-001 power supply operates within specifications at altitudes up to 6000 feet above sea level (ambient temperature derated to 45°C at 10,000 feet).

The power supply will not be damaged when stored at altitudes of up to 50,000 feet above sea level.

Humidity

Operating: DS1100SLPE-3 series power supply operates with no degradation of performance while operating in range of 5% RH to 95%RH non-condensing.

Non-Operating: DS1100SLPE-3 series power supply operates with no degradation of performance while operating in range of 5%RH to 95%RH non-condensing.

Vibration

DS1100SLPE-3 series power supply passed the following random non-operational and non-operation vibration at levels according to the graph below:

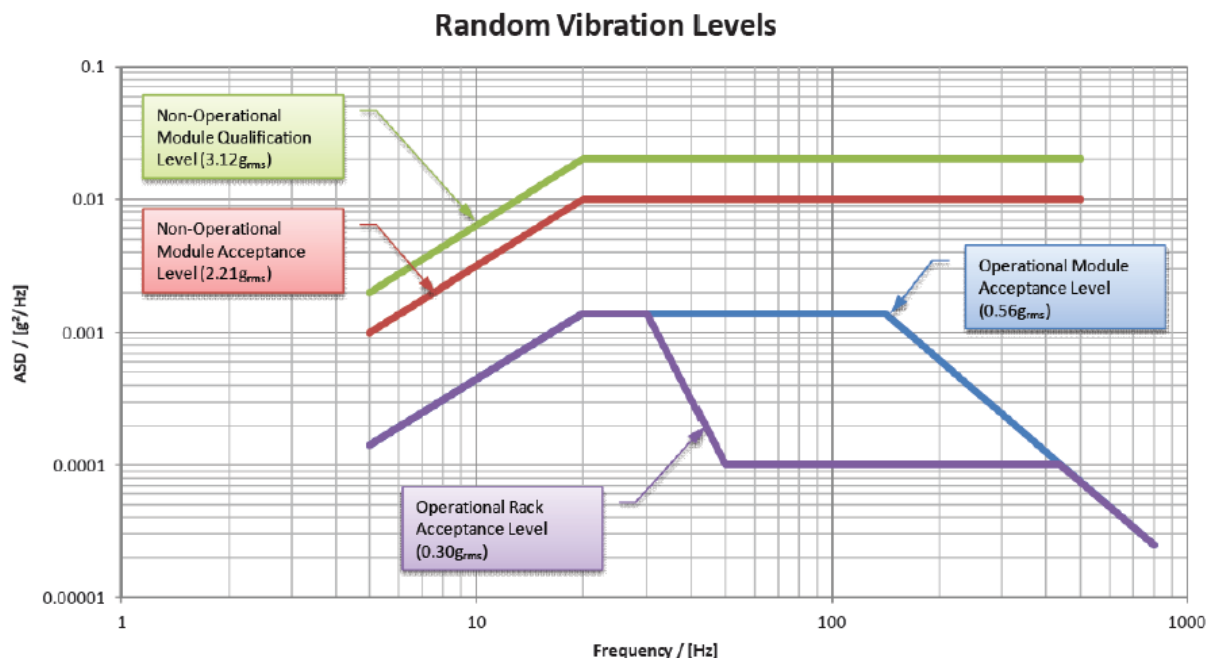

DS1100SLPE-3 series power supply subjected to a swept sinusoidal vibration test at an acceleration amplitude of 0.5 g from 5 to 200 Hz and back to 5 Hz at 0.1 octave/minute, performed for 90 minutes for each of the three mutually perpendicular axes.

Shock

DS1100SLPE-3 series power supply passed the following shock specifications:

Non-Operating Half-Sine Shock

Acceleration	30	G
Duration	18	mSec
Pulse	Half-sine shock	
No. of Shock	3 time on all 6 faces	

Operating Half-Sine Shock

Acceleration	15	G
Duration	11	mSec
Pulse	Half-sine shock	
No. of Shock	3 times on all 6 faces	

All components within the power supply will be appropriately secured to prevent failure resulting from these tests. At the conclusion of any of the above referenced Shock/Vibration tests listed in this section of this document, the power supply will be powered up under maximum rated load and will perform within specification.

Acoustic

DS1100SLPE-3 series power supply noise level will not exceed 43dB when operated at 115Vac/230Vac, at 60% load, 40degC and 6,000ft. At worst case condition, the power supply noise shall not exceed 76dB.

Power and Control Signal Descriptions

AC Input Connector

This connector supplies the AC Mains to DS1100SLPE-3 series power supply.

- Pin 1 - L
- Pin 2 - N
- Pin 3 - Earth Ground

Output Connector - Power Blades

These pins provide the main output for the DS1100SLPE-3. The + Main Output (V_O) and the Main Output Return pins are the positive and negative rails, respectively, of the V_O main output of the DS1100SLPE-3 power supply. The Main Output (V_O) is electrically isolated from the power supply chassis ground at least 50V.

- P1-P5 - +12V Return
- P6-P10 - 12V

Output Connector - Control Signals

DS1100SLPE-3 series power supply contains a 25 pins control signal header providing an analogue control interface, standby power and I²C interface signal connections.

Standby Output - (pins A1, B1, C1, D1, E1)

DS1100SLPE-3 series power supply provides a regulated 3.3V 3A auxiliary output voltage to power critical circuitry that must remain active regardless of the on/off status of the power supply's main output. The Standby Output (V_{SB}) voltage is available whenever a valid DC input voltage is applied to the unit.

A0, A1, A2 - (pins B3, D4, A3)

Please refer to "Communication Bus Descriptions" section.

SDA, SCL and PS_INTERRUPT_L - (pins C3, A4, C4)

Please refer to "Communication Bus Descriptions" section.

Main Output Remote Sense Return, Main Output Remote Sense - (pins D3, E3)

The main output of the DS1100SLPE-3 is equipped with a Remote Sensing capability that will compensate for a power path drop around the entire loop of 200 mV. This feature is implemented by connecting the Main Output Remote Sense (pin E3) and the Main Output Remote Sense Return (pin D3) to the positive and negative rails of the main output, respectively, at a location that is near to the load. This remote sense circuit will not raise the power supply's output voltage to the OVP trip level. Main Output Remote Sense has no effect on the standby output (V_{SB}).

In the event of a failure of the Remote Sense lines, the output voltage will revert to the internal sense so as to limit the output voltage to less than 105% of the nominal.

PSON_L - (pin B4)

This signal input pin controls the normal turning ON and OFF of the Main Output of the DS1100SLPE-3 power supply. The power supply main output (V_O) will be enabled when this signal is pulled low, below 0.8V. The power supply output (except V_{SB} output) will be disabled when this input is driven higher than 2.0V, or open circuited. It's recommended that to this pin is pulled up to $3.3V_{SB}$ by a 5.1Kohm resistor and pulled down with a switch and 100pF decoupling capacitor to GND.

Power supply side

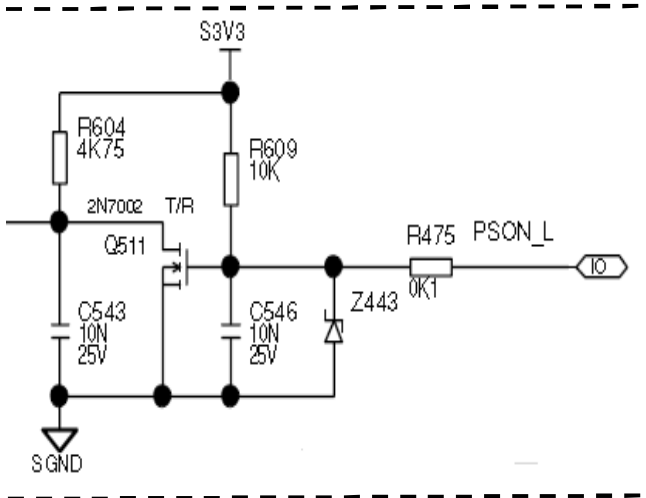

Customer system side

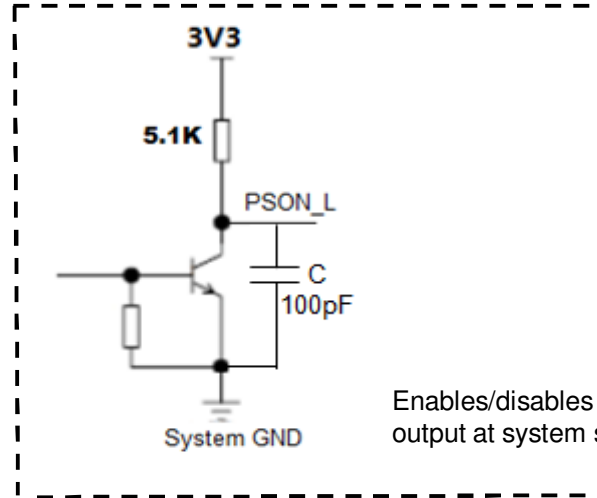

AC_OK - (pin E4)

Signal used to indicate the presence of DC input to the power supply. A logic level HIGH will indicate that the DC input to the power supply is within the operating range while a logic level LOW will indicate that DC input has been lost. This is an open collector/drain output. This pin is pulled high by a 10K ohm resistor connected to 3.3V inside the power supply. It is recommended that this pin is connected to a 200pF decoupling capacitor and pulled down by a 100K ohm resistor.

Power supply side

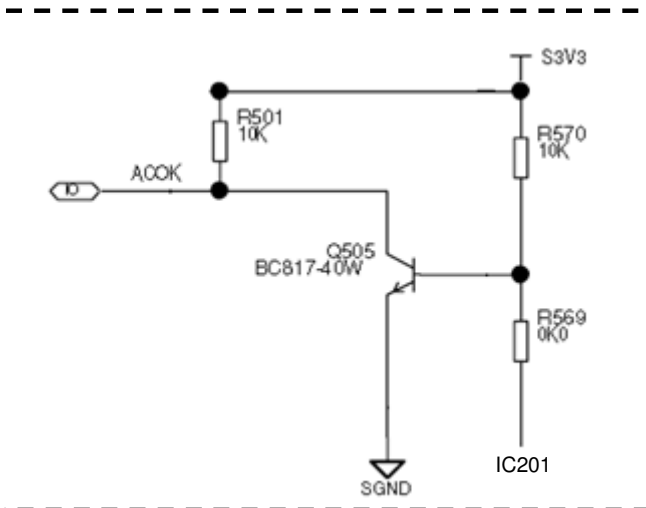

Customer system side

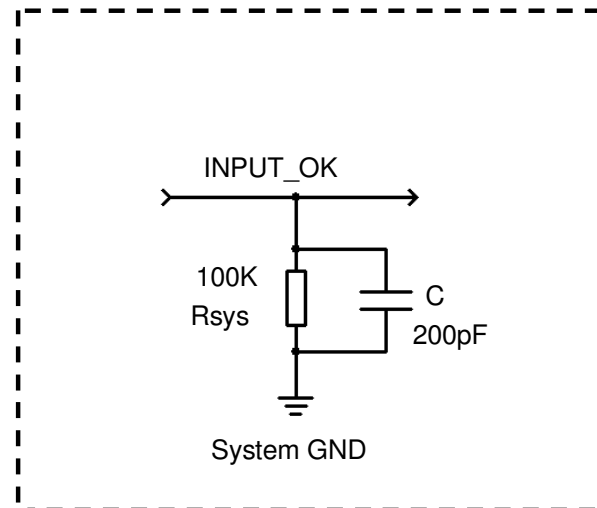

PSKILL_L - (pin A5)

First break/Last Mate active HIGH signal which enables/disables the main output. When this signal is shorted to ground by the system, the 12V main output will be enabled. This signal will have to be pulled to ground at the system side with a 100 ohm resistor. A 100pF decoupling capacitor is also recommended.

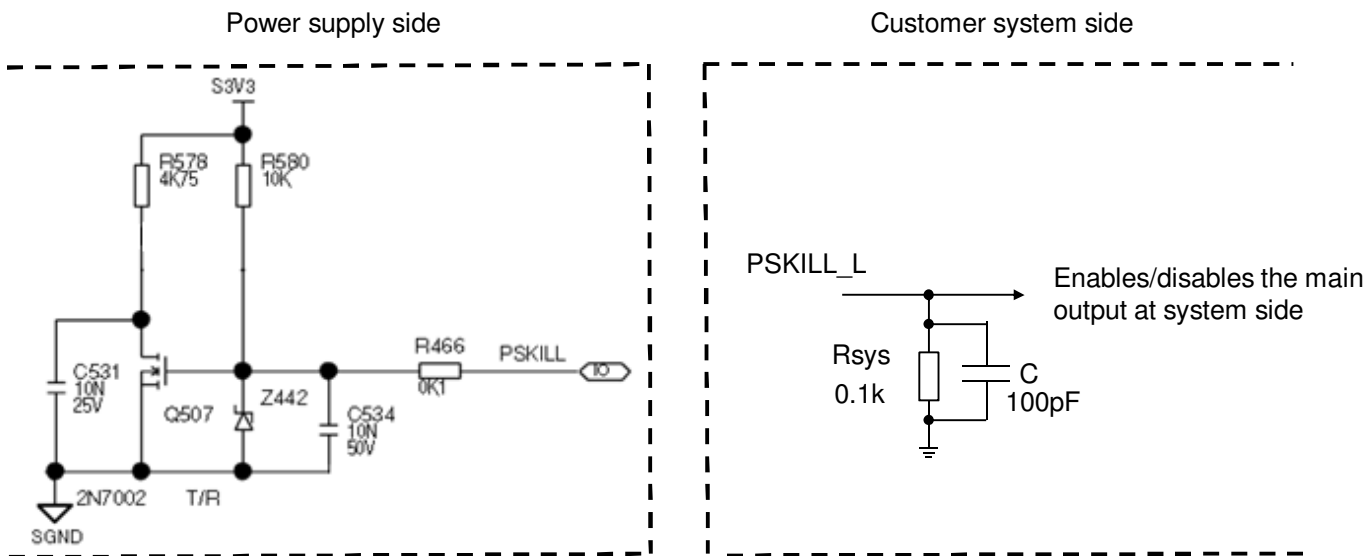

ISHARE - (pin S7)

DS1100SLPE-3 series power supply supports active current sharing through a single wire connection between the power supplies. This input/output signal pin allows two or more power supplies to share the main output load current to increase the overall power capability or to operate the units in a N+N configuration for redundancy purposes.

All outputs of the DS1100SLPE-3 with ISHARE pins connected will share load current and the current share errors (CSE) is within 5.625A of each. If any power supply is hot swapped, no glitch will occur that violates the regulation limits of the power supply defined in this specification. The current share loop should be activated when the output current exceed 7% of total load current.

The voltage of this signal is a linear slope from no load to full load. At 10% load of each power supply output when two supplies are running in parallel, the ISHARE voltage will be between 0.6V and 1.0V. At 50% load of each power supply output when two supplies are running in parallel, the ISHARE voltage will be between 3.85V and 4.15V. At 100% load of each power supply output when two supplies are running in parallel, the ISHARE voltage will be between 7.75V and 8.25V. The waveform for this signal will be provided to confirm stability during parallel mode operation.

PWOK - (pin C5)

Signal used to indicate that main output voltage is within regulation range. The PWOK signal will be driven HIGH (>2.0V) when the output voltage is valid and will be driven LOW (<0.8V) when the output falls below the under-voltage threshold. This signal also gives an advance warning when there is an impending power loss due to loss of DC input or system shutdown request.

This is an open collector/drain output. This pin is pulled high by a 10K ohm resistor connected to 3.3V inside the power supply. It is recommended that this pin be connected to a 100pF decoupling capacitor and pulled down by a 100K ohm resistor.

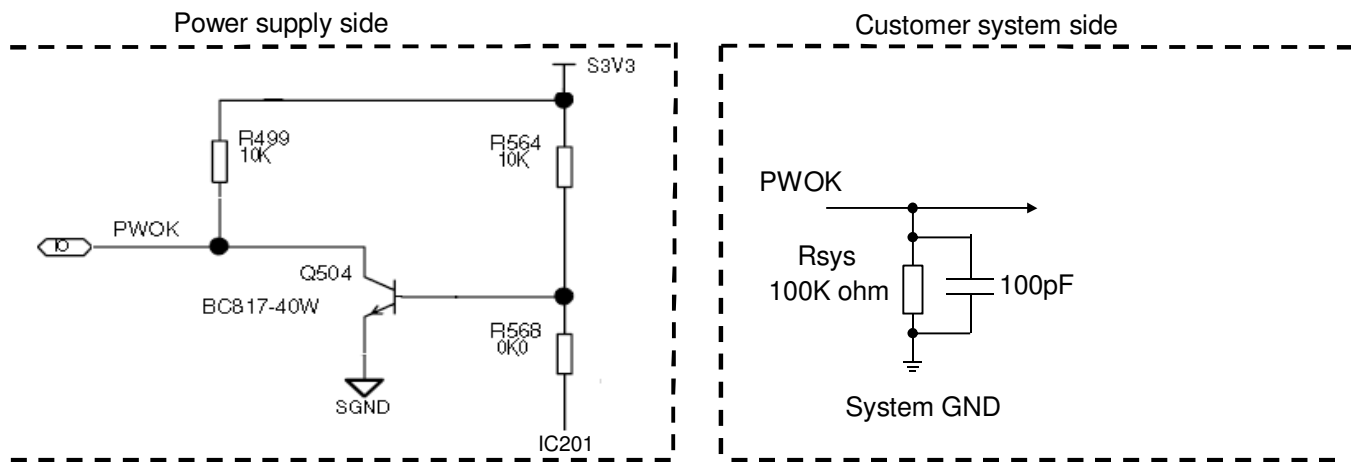

PS_PRESENT_L - (pin E5)

Signal used to indicate to the system that a power supply is inserted in the power bay. This pin is shorted to the Standby return via 220ohm resistor in the power supply. Recommended pull-up resistor to $3.3V_{SB}$ is 5.1K ohm. A 100pF decoupling capacitor is also recommended.

Communication Bus Descriptions

I²C Bus Signals

DS1100SLPE-3 series power supply contains enhanced monitor and control functions implemented via the I²C bus. The DS1100SLPE-3 I²C functionality (PMBus™ and FRU data) can be accessed via the output connector control signals. The communication bus is powered either by the internal 3.3V supply or from an external power source connected to the Standby Output (i.e. accessing an unpowered power supply as long as the Standby Output of another power supply connected in parallel is on).

If units are connected in parallel or in redundant mode, the Standby Outputs must be connected together in the system. Otherwise, the I²C bus will not work properly when a unit is inserted into the system without the DC source connected.

Note: PMBus™ functionality can be accessed only when the PSU is powered-up.
Guaranteed communication I²C speed is 100K Hz.

A0, A1, A2 (I²C Address Signals) - (pins B3, D4, A3)

These input pins are the address lines A0 and A1 to indicate the slot position the power supply occupies in the power bay and define the power supply addresses for FRU data and PMBus™ data communication. This allows the system to assign different addresses for each power supply. During I²C communication between system and power supplies, the system will be the master and power supplies will be slave.

They are internally pulled up to internal 3.3V supply with a 10K resistor.

Note: A2 address line will be an optional address line. By default, the power supply address will ignore the A2 input and will rely exclusively on A0 and A1 logic levels. The address will begin at B0h and A0h. The default address of the power supply will be B6/B7 and A6/A7 when the address lines are left open. This ignores the logic level of A2.

SDA, SCL (I²C Data and Clock Signals) - (pins C3, A4)

I²C serial data and clock bus - these pins are internally pulled up to internal 3.3V supply with a 10K ohm resistor. These pins must be pulled-up by a 2.2K ohm resistor to 3.3V and a 200pF decoupling capacitor at the system side.

PS_INTERRUPT_L - (pin C4)

PS_INTERRUPT is used to send a signal to the system that a fault in the power supply occurred. This signal is normally logic level HIGH. It will go to a LOW logic level when a fault bit has been set in the power supply's status register. This event can be triggered by faults such as OVP, OCP, OTP, and fan fault. The conditions wherein the signal goes back to high are: (1) DC recycle, (2) PSON recycle and (3) issuance of a CLEAR_FAULTS PMBus command. Recommended pull-up resistor to 3.3V V_{SB} is 5.1K ohm. A 100pF decoupling capacitor is also recommended.

I²C Bus Communication Interval

The interval between two consecutive I²C communications to the power supply should be at least 15ms to ensure proper monitoring functionality.

I²C Bus Signal Integrity

The noise on the I²C bus (SDA, SCL lines) due to the power supply will be less than 300mV peak-to-peak. This noise measurement should be made with an oscilloscope bandwidth limited to 100MHz. Measurements should be made at the power supply output connector with 10K ohm resistors pulled up to Standby Output and 47pF ceramic capacitors to Standby Output Return.

I²C Bus Internal Implementation, Pull-ups and Bus Capacitances

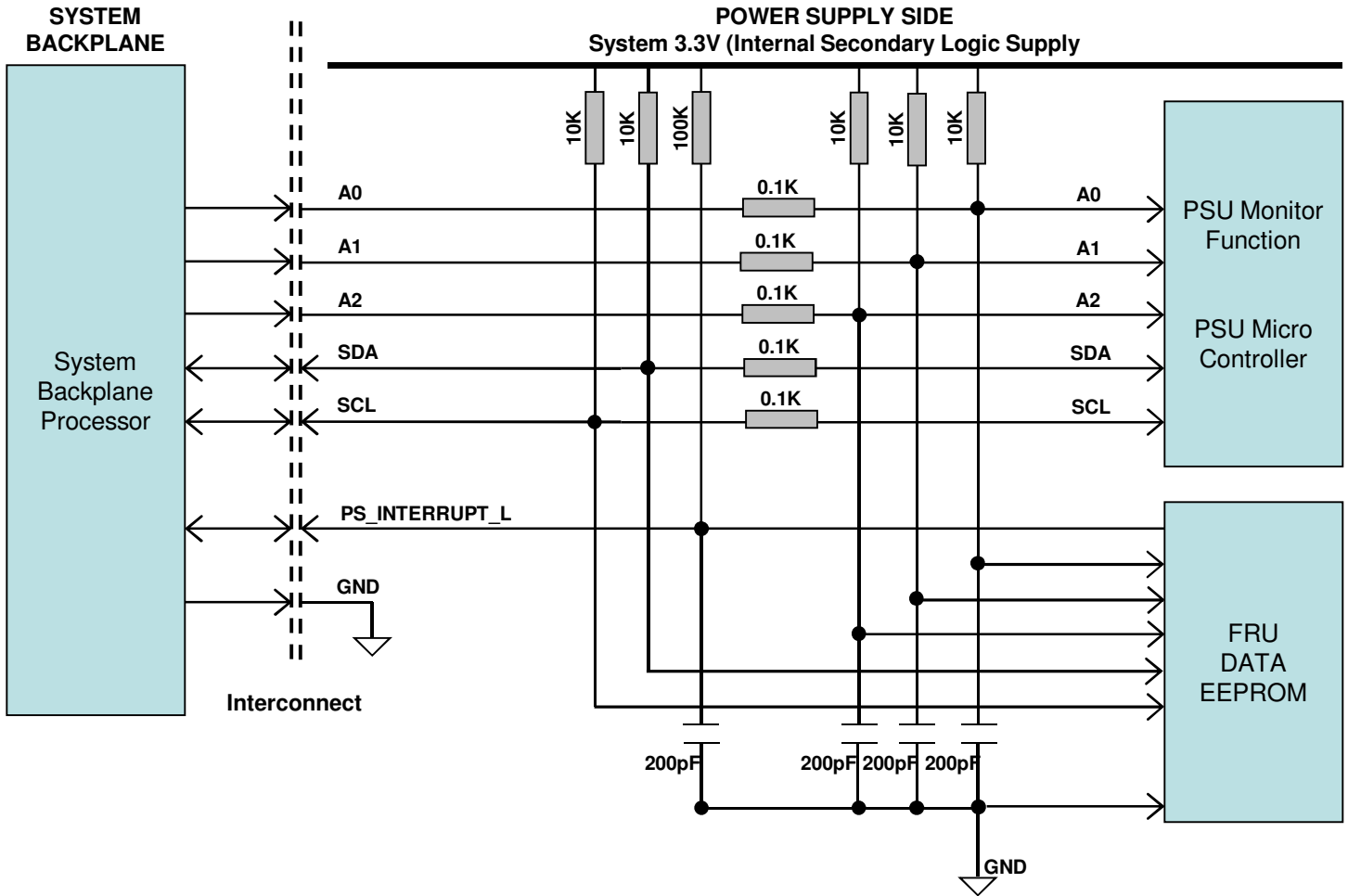

I²C Bus - Recommended external pull-ups:

Electrical and Interface specifications of I²C signals (referenced to Standby Output Return pin, unless otherwise indicated):

Parameter	Condition	Symbol	Min	Typ	Max	Unit
SDA, SCL internal pull-up resistor		R_{int}	-	10	-	Kohm
SDA, SCL recommended external bus capacitance		C_{ext}		200		pF
Recommended external pull-up resistor	1 to 4 PSU	R_{ext}	-	2.2	-	Kohm

Logic Levels

DS1100SLPE-3 series power supply I²C communication bus will respond to logic levels as per below:

Logic High: 3.3V Nominal (Specs is 2.1V to 5.5V)**

Logic Low: 500mV nominal (Specs is 800mV max)**

** Note : Artesyn 73-769-001 I²C adapter was used.

Timings

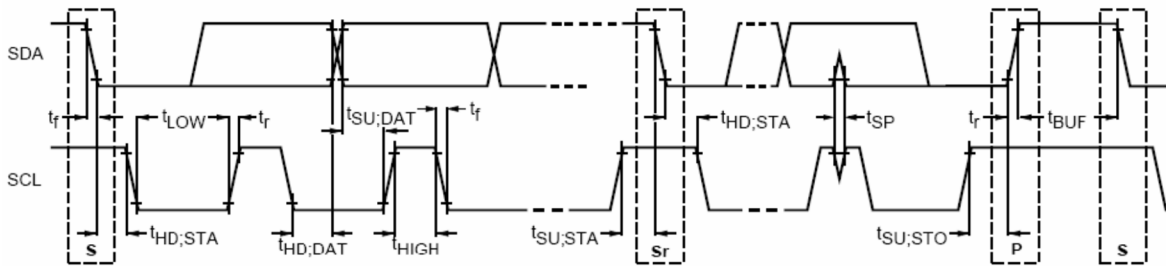

Parameter	Symbol	Standard-Mode Specs		Actual		Unit
		Min	Max			
SCL Clock Frequency	f_{SCL}	0	100	100		KHz
Hold time (repeated) START condition	$t_{HD;STA}$	4.0	-	4.98		μ Sec
LOW period of SCL clock	t_{LOW}	4.7	-	4.95		μ Sec
HIGH period of SCL clock	t_{HIGH}	4.0	-	4.0		μ Sec
Setup time for repeated START condition	$t_{SU;STA}$	4.7	-	4.8		μ Sec
Data hold time	$t_{HD;DAT}$	0	3.45	0.2		μ Sec
Data setup time	$t_{SU;DAT}$	250	-	4800		nSec
Rise time	t_r	-	1000	SCL = 720	SDA = 740	nSec
Fall time	t_f	-	300	SCL = 190	SDA = 210	nSec
Setup time for STOP condition	$t_{SU;STO}$	4.0	-	5.3		μ Sec
Bus free time between a STOP and START condition	t_{BUF}	4.7	-	30.6		mSec

Device Addressing

DS1100SLPE-3 series power supply will respond to supported commands on the I2C bus that are addressed according to pins A1 and A0 pins of output connector.

Address pins are held HIGH by default via pulled up to internal 3.3V supply with a 2.2K resistor. To set the address as “0”, the corresponding address line should be pulled down to logic ground level. Below tables show the address of the power supply with A0 and A1 pins set to either “0” or “1”.

DS1100SLPE-3 series power supply can be used singly or in n + 1 (n = 1,2 or 3) configuration. The power supply addressing, refers to the address of each power supply if it is used in N + 1 configuration. This will allow the system to assign different addresses for each PSU. During I2C communication between system and PSU, the system will be the master and the PSU will be slave. The address lines (A1 and A0) are pulled up to +3V3standby internally. To set the address as “low” the corresponding address should be pulled down to Ground (reference).

PSU Slot	Slot ID Bits			PMBus™ Address		EEPROM (FRU) Address	
	A2 ¹	A1	A0	WRITE	READ	WRITE	READ
1	0	0	0	0xB0	0xB1	0xA0	0xA1
2	0	0	1	0xB2	0xB3	0xA2	0xA3
3	0	1	0	0xB4	0xB5	0xA4	0xA5
4	0	1	1	0xB6	0xB7	0xA6	0xA7
5	1	0	0	0xB8	0xB9	0xA8	0xA9
6	1	0	1	0xBA	0xBB	0xAA	0xAB
7	1	1	0	0xBC	0xBD	0xAC	0xAD
8	1	1	1	0xBE	0xBF	0xAE	0xAF

Note 1 - A2 address line is an optional address line. By default, the power supply address will ignore the A2 input and will rely exclusively on A0 and A1 logic levels. The address will begin at B0h and A0h. The default address of the power supply are B6/B7 and A6/A7 when the address lines are left open. This ignores the logic level of A2.

Reporting Functions

The power supply will have enhanced monitor and control functions implemented via the I²C bus. This will use the SDA and SCL pins. The power supply monitor will operate as an I²C slave device. The accuracy of the report functions will be as follows:

Firmware Reporting And Monitoring			
Output loading ¹	<10%	10 to 20%	20 to 100%
Input voltage	±5%		
Input current ²	±1.0A fixed error	±10%	±5%
Input power ³	30W fixed error up to 120W input power	±15%	±10%
Output voltage	±5%		±2%
Output current	±0.8A fixed error	±5%	±2%
Output power	12.0W fixed error	±15%	±5%
Temperature	±5 degC on the operating range		
Fan speed	Actual ±250 RPM		

PMBus	Yes
Remote ON/OFF	Yes

Note 1 - Accuracy percentages are applicable for when the input voltage is at 115Vac/230Vac and the operating temperature is at 25degC.

Note 2 - When the input current is less than 0.4A, the input current and input power can report a zero.

Note 3 - A power supply without input power in redundant mode operation will report zero input parameters.

I²C Clock Synchronization

The DS1100SLPE-3 power supply might apply clock stretching. An addressed slave power supply may hold the clock line (SCL) low after receiving (or sending) a byte, indicating that it is not yet ready to process more data.

The system master that is communicating with the power supply will attempt to raise the clock to transfer the next bit, but must verify that the clock line was actually raised. If the power supply is clock stretching, the clock line will still be low (because the connections are open-drain).

The maximum time out condition for clock stretching for DS1100SLPE-3 is 25 millisecond.

The power supply has a command completion timeout of 100 millisecond. That is, a single transaction (from START to STOP condition) must be finished within 100 millisecond.

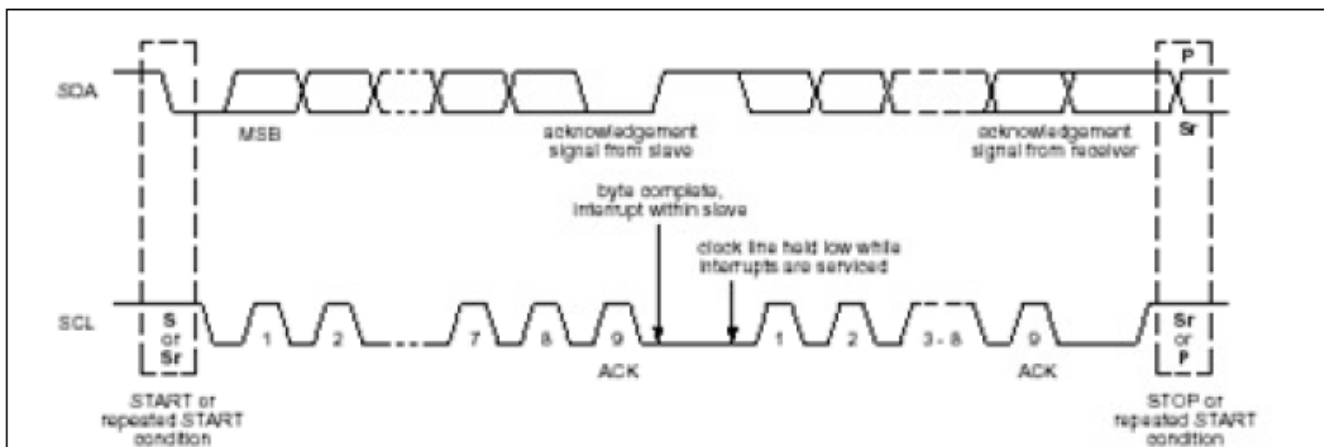

FRU (EEPROM) Data

The FRU (Field Replaceable Unit) data format is compliant with the Intel PSMI V2.12 specification.

The DS1100SLPE-3 uses 1 page of EEPROM for FRU purpose. A page of EEPROM contains up to 256 byte-sized data locations.

Where: **OFFSET** - The **OFFSET** denotes the address in decimal format of a particular data byte within DS1100SLPE-3 EEPROM.

VALUE - The **VALUE** details data written to a particular memory location of the EEPROM.

DEFINITION - The contents **DEFINITION** refers to the definition of a particular data byte.

DS1100SLPE-3 FRU (EEPROM) Data:

OFFSET		DEFINITION (REMARKS)	SPEC VALUE	
(DEC)	(HEX)		(DEC)	(HEX)
COMMON HEADER, 8 BYTES				
0	00	FORMAT VERSION NUMBER (Common Header) 7:4 - Reserved, write as 0000b 3:0 - Format Version Number = 1h for this specification	1	01
1	01	INTERNAL USE AREA OFFSET	27	1B
2	02	CHASSIS INFO AREA OFFSET	1	01
3	03	BOARD INFO AREA OFFSET	0	00
4	04	PRODUCT INFO AREA OFFSET	5	05
5	05	MULTI RECORD AREA OFFSET	13	0D
6	06	PAD (reserved) Default value is 0.	0	00
7	07	ZERO CHECK SUM (256 - (Sum of bytes 0 to 6))	209	D1
CHASSIS INFO AREA(32 BYTES) This area will be filled by the Mfg. Diag. or by the OS if used.				
8	08	FORMAT VERSION NUMBER (Default value is 0.) 7:4 - Reserved, write as 0000b 3:0 - Format Version Number = 1h for this specification	1	01
9	09	CHASSIS INFO AREA LENGTH in multiple of 8 bytes	4	04
10	0A	CHASSIS TYPE (Default value is 0.)	0	00
11	0B	CHASSIS PART NUMBER Type/Length CAh (if used) Type = "ASCII+LATIN1" = (11)b Length = 10 Bytes = (001010)b	202	CA
12	0C	CHASSIS PART NUMBER BYTES (Default value is 0.)	0	00
13	0D		0	00
14	0E		0	00
15	0F		0	00
16	10		0	00
17	11		0	00
18	12		0	00
19	13		0	00
20	14		0	00
21	15		0	00
22	16	CHASSIS SERIAL NUMBER Type/Length CFH (if used) Type = "ASCII+LATIN1" = (11)b Length = 7 Bytes = (001111)b	207	CF
23	17	CHASSIS SERIAL NUMBER BYTES , Default value is 0.	0	00
24	18		0	00
25	19		0	00
26	1A		0	00
27	1B		0	00
28	1C		0	00
29	1D		0	00
30	1E		0	00
31	1F		0	00

DS1100SLPE-3 FRU (EEPROM) Data:

OFFSET		DEFINITION (REMARKS)	SPEC VALUE	
(DEC)	(HEX)		(DEC)	(HEX)
32	20		0	00
33	21		0	00
34	22		0	00
35	23		0	00
36	24		0	00
37	25		0	00
38	26	End Tag (0C1h if used)	193	C1
39	27	CHKSUM (Zero CHKSUM (256-(sum of bytes 8 to 38)))	161	A1
PRODUCT INFORMATION AREA, 64 BYTES				
40	28	FORMAT VERSION NUMBER (Product Info Area) 7:4 - Reserved, write as 0000b 3:0 - Format Version Number = 1h for this specification	1	01
41	29	PRODUCT INFO AREA LENGTH (In multiples of 8 bytes)	8	08
42	2A	Language (English)	25	19
43	2B	MANUFACTURER NAME Type/Length (0C5H) 7:6 - (11)b, 8-Bit ASCII + Latin 1, 5:0 - (000101)b, 5-Byte Allocation	199	C7
44	2C	MANUFACTURER'S NAME 5 byte sequence "A" = 41h	65	41
45	2D	"R" = 52h	82	52
46	2E	"T" = 54h	84	54
47	2F	"E" = 45h	69	45
48	30	"S" = 53h	83	53
49	31	"Y" = 59h	89	59
50	32	"N" = 4Eh	78	4E
51	33	PRODUCT NAME Type/Length (CFH) Type = "ASCII+LATIN1" = (11)b Length = 15 Bytes = (001111)b	207	CF
52	34	PRODUCT NAME BYTES (16 Bytes sequence) "D" = 44H	68	44
53	35	"S" = 53H	83	53
54	36	"1" = 31H	49	31
55	37	"1" = 31H	49	31
56	38	"0" = 30H	48	30
57	39	"0" = 30H	48	30
58	3A	"S" = 53H	83	53
59	3B	"L" = 4CH	76	4C
60	3C	"P" = 50H	80	50
61	3D	"E" = 45H	69	45
62	3E	"-" = 2DH	45	2D
63	3F	"3" = 33H	51	33
64	40	"-" = 2DH (For DS1100SLPE-3-001 only)	45	2D
65	41	"0" = 30H (For DS1100SLPE-3-001 only)	48	30
66	42	"0" = 30H (For DS1100SLPE-3-001 only)	48	30
67	43	"1" = 31H (For DS1100SLPE-3-001 only)	49	31
68	44	PRODUCT PART/MODEL NUMBER Type/Length (CFH) Type = "ASCII+LATIN1" = (11)b Length = 15 Bytes = (001111)b	207	CF

Technical Reference Note

DS1100SLPE-3 FRU (EEPROM) Data:

OFFSET		DEFINITION (REMARKS)	SPEC VALUE	
(DEC)	(HEX)		(DEC)	(HEX)
PRODUCT PART/MODEL NUMBER BYTES				
69	45	"D" = 44H	68	44
70	46	"S" = 53H	83	53
71	47	"1" = 31H	49	31
72	48	"1" = 31H	49	31
73	49	"0" = 30H	48	30
74	4A	"0" = 30H	48	30
75	4B	"S" = 53H	83	53
76	4C	"L" = 4CH	76	4C
77	4D	"P" = 50H	80	50
78	4E	"E" = 45H	69	45
79	4F	"-" = 2DH	45	2D
80	50	"3" = 33H	51	33
81	51	"-" = 2DH (For DS1100SLPE-3-001 only)	45	2D
82	52	"0" = 30H (For DS1100SLPE-3-001 only)	48	30
83	53	"0" = 30H (For DS1100SLPE-3-001 only)	48	30
84	54	"1" = 31H (For DS1100SLPE-3-001 only)	49	31
PRODUCT VERSION NUMBER Type/Length (C2H)				
85	55	Type = "ASCII+LATIN1" = (11)b Length = 2 Bytes = (000010)b	194	C2
PRODUCT VERSION NUMBER BYTES				
86	56	Refer to Section 0.0 Product Revision History in latest Product Specification	48	30
87	57		65	36
PRODUCT SERIAL NUMBER Type/Length				
88	58	Type = "ASCII+LATIN1" = (11)b Length = 13 bytes = (001101)b	205	CD
PRODUCT SERIAL NUMBER BYTES				
Model ID = K739 (DS1100SLPE-3)				
Model ID = K740 (DS1100SLPE-3-001)				
89	59	K	75	4B
90	5A	7	55	37
91	5B	3	51	33
92	5C	9	57	39
MANUFACTURING YEAR AND WEEK CODE				
93	5D	"W" = 57h (Per Unit)		00
94	5E	"W" = 57h (Per Unit)		00
UNIQUE SERIAL NUMBER				
"SSSS"				
95	5F	"S" = 53H (Per Unit)	83	53
96	60	"S" = 53H (Per Unit)	83	53
97	61	"S" = 53H (Per Unit)	83	53
98	62	"S" = 53H (Per Unit)	83	53
MODEL REVISION				
Astec Model Rev, See Latest Model Rev in IPRO				
99	63			00
100	64			00
MANUFACTURING LOCATION				
101	65	"Z" for "Zhongshan" In Decimal = 090 In Hex = 5AH	90	5A
102	66	End Tag	193	C1
PAD (reserved) (Default value is 0.)				
103	67		0	00
104	68		0	00
105	69	ZERO CHECK SUM(256-(sum of bytes 40 to 104)) Per Unit Zero Check Sum :Should follow check sum calculation as per IPMI v1.1	xxx	xx

Technical Reference Note

DS1100SLPE-3 FRU (EEPROM) Data:

OFFSET		DEFINITION (REMARKS)	SPEC VALUE	
(DEC)	(HEX)		(DEC)	(HEX)
Multi Record Area, 88 Bytes				
Power Supply Record Header				
106	6A	Record type = 00 for Power supply	0	00
107	6B	End of List /Record Format Version Number	2	02
108	6C	Record Length of Power Supply Record	24	18
109	6D	Record CHECKSUM of Power Supply Record (Zero CHECKSUM) (256-(sum of bytes 111 to 130))	185	B9
110	6E	Header CHECKSUM of Power Supply Record Header (Zero CHECKSUM) (256-(sum of bytes 106 to 109))	45	2D
Power Supply Record				
Overall Capacity of the Power Supply				
111	6F	2 Bytes Sequence DS1100SLP-3 = 1100W; DS1100SLPE-3-001 = 1100W	76	4C
112	70	1100W = 044CH	4	04
Peak VA, 1265VA=04F1H				
2 Bytes Sequence				
113	71	In Decimal = 241, In Hex = F1H	241	F1
114	72	In Decimal = 4, In Hex = 04H	4	04
Inrush Current, 50A				
115	73	In Decimal = 50, In Hex = 32H	50	32
Inrush Interval, 10mS				
116	74	In Decimal = 10, In Hex = 0AH,	10	0A
Low End Input Voltage Range 1(10mV), (90V / 10mV) 9000 = 2328H				
2 Bytes Sequence				
117	75	In Decimal = 40, In Hex = 28H	40	28
118	76	In Decimal = 35, In Hex = 23H	35	23
High End Input Voltage Range 1(10mV), (264V/10mV) 26400= 6720H				
2 Bytes Sequence				
119	77	In Decimal = 32, In Hex = 20H	32	20
120	78	In Decimal = 103, In Hex = 67H	103	67
121	79	Low End Input Frequency Range, 47Hz = 2FH	47	2F
122	7A	Low End Input Frequency Range, 63Hz = 3FH	63	3F
123	7B	AC Dropout Tolerance in mS, 10mS=0AH	10	0A
124	7C	Binary Flags, 1 indicates function supported and a 0 indicates function not supported. Bits 7-5: RESERVED, WRITE AS 000B Bit 4: Tachometer Pulses Per Rotation / Predictive Fail Polarity BIT= 1 Bit 3: Hot Swap / Redundancy Support BIT = 1 Bit 2: Auto switch Support BIT = 1 Bit 1: Power Factor Correction Support BIT = 1 Bit 0: Predictive Fail Support BIT = 0	30	1E
Peak Wattage Capacity and Holdup Time				
125	7D	For DS1100SLPE-3 = DS1100SLPE3-001 = 14mS = 0EH;	14	0E
126	7E	In Decimal = 14, In Hex = 0EH In Decimal = 0, In Hex = 00H	0	00
Combined Wattage				
127	7F	Byte 1: 0000 0000 = 00H = 00D (12V0 - voltage1) Byte 2 and Byte 3: 00H, 00H		
128	80	1100W = 044CH	76	4C
129	81	For DS1100SLPE-3 = 044CH ; For DS1100SLPE3-001 = 044CH;	4	04
130	82	Predictive Fail Tachometer Lower Threshold, Not Applicable. Predictive Failure is not Supported.	0	00

Technical Reference Note

DS1100SLPE-3 FRU (EEPROM) Data:

OFFSET		DEFINITION (REMARKS)	SPEC VALUE	
(DEC)	(HEX)		(DEC)	(HEX)
12V DC OUTPUT RECORD HEADER				
131	83	Record type = 01 for DC Output Record	1	01
132	84	End of List /Record Format Version Number for 12V DC Output Record	2	02
133	85	Record Length of 12V DC Output Record	13	0D
134	86	Record CHECKSUM of 12V DC Output Record (Zero CHECKSUM) (256-(sum of bytes 136 to 148))	228	E4
135	87	Header CHECKSUM of 12V DC Output Record Header (Zero CHECKSUM) (256-(sum of bytes 131 to 134))	12	0C
12V OUTPUT RECORD				
136	88	Output Information, 001 = 01H Bit 7: Standby Information = 0B Bits 6-4: Reserved, Write as 000B Bits 3-0: Output Number 1 = 001B	1	01
137	89	Nominal Voltage (10mV), (12V / 10mV) 1200 = 04B0H 2 Bytes Sequence In Decimal: 176, In Hex: B0H In Decimal: 4, In Hex: 04H	176	B0
138	8A		4	04
139	8B	Maximum Negative Voltage Deviation (10mV), 1164 = 048CH 2 Bytes Sequence In Decimal: 140, In Hex: 8CH In Decimal: 4, In Hex: 04H	140	8C
140	8C		4	04
141	8D	Maximum Positive Voltage Deviation (10mV), 1236 = 04D4H 2 Bytes Sequence In Decimal: 212, In Hex: D4H In Decimal: 4, In Hex: 04H	212	D4
142	8E		4	04
143	8F	Ripple and Noise pk-pk (mV), 180 = B4H 2 Bytes Sequence In Decimal: 180, In Hex: B4H In Decimal: 0, In Hex: 00H	180	B4
144	90		0	00
145	91	Minimum Current Draw (10mA), (0A / 10mA) 10 = 0000H 2 Bytes Sequence In Decimal: 0, In Hex: 00H In Decimal: 0, In Hex: 00H	0	00
146	92		0	00
147	93	Maximum Current Draw (10mA), 2 Bytes Sequence 9000*10mA = 2328H For DS1100SLPE-3 9000*10mA = 2328h For DS1100SLPE-3-001	40	28
148	94		35	23
V_{SB} OUTPUT RECORD HEADER				
149	95	Record type = 01 for DC Output Record	1	01
150	96	End of List /Record Format Version Number for 3V3SB Output Record	2	02
151	97	Record Length of 3V3SB Output Record	13	0D
152	98	Record CHECKSUM of 3V3SB Output Record (Zero CHECKSUM) (256-(sum of bytes 154 to 166))	67	43
153	99	Header CHECKSUM of 3V3SB Output Record Header (Zero CHECKSUM) (256-(sum of bytes 149 to 152))	173	AD
V_{SB} OUTPUT RECORD				
154	9A	Output Information, 002 = 02H Bit 7: Standby Information = 1B Bits 6-4: Reserved, Write as 000B Bits 3-0: Output Number 1 = 0010B	130	82
155	9B	Nominal Voltage (10mV), (3.3V / 10mV) 330 = 014AH 2 Bytes Sequence In Decimal: 74, In Hex: 4AH In Decimal: 1, In Hex: 01H	74	4A
156	9C		1	01

Technical Reference Note

DS1100SLPE-3 FRU (EEPROM) Data:

OFFSET		DEFINITION	SPEC VALUE	
(DEC)	(HEX)	(REMARKS)	(DEC)	(HEX)
157	9D	Maximum Negative Voltage Deviation (10mV), 314 = 013AH 2 Bytes Sequence In Decimal: 58, In Hex: 3AH In Decimal: 1, In Hex: 01H	58	3A
158	9E		1	01
159	9F	Maximum Positive Voltage Deviation (10mV), 346 =015AH 2 Bytes Sequence In Decimal: 212, In Hex: D4H In Decimal: 4, In Hex: 04H	90	5A
160	A0		1	01
161	A1	Ripple and Noise pk-pk (mV), 45 = 2DH 2 Bytes Sequence In Decimal: 45, In Hex: 2DH In Decimal: 0, In Hex: 00H	45	2D
162	A2		0	00
163	A3	Minimum Current Draw (10mA), (0A / 10mA) 10 = 00H 2 Bytes Sequence In Decimal: 0, In Hex: 00H In Decimal: 0, In Hex: 00H	0	00
164	A4		0	00
165	A5	Maximum Current Draw (4A), (3.0A / 10mA) 300 = 012CH 2 Bytes Sequence In Decimal: 44, In Hex: 2CH In Decimal: 1, In Hex: 01H	44	2C
166	A6		1	01
OEM RECORD HEADER				
167	A7	Record type = C0H for OEM Record	192	C0
168	A8	End of List /Record Format Version Number for 3.3Vsb output Record	130	82
169	A9	Record Length of OEM Record	42	2A
170	AA	Record CHECKSUM of OEM Record (Zero CHECKSUM) (256-(sum of bytes 172 to 213)	0	00
171	AB	Header CHECKSUM of OEM Record Header (Zero CHECKSUM) (256-(sum of bytes 167 to 170)	148	94
OEM RECORD				
172	AC	Manufacturer ID (3 bytes, Default is 0)	0	00
173	AD	RESERVED	0	00
174	AE	RESERVED	0	00
175	AF	RESERVED	0	00
176	B0	RESERVED	0	00
177	B1	RESERVED	0	00
178	B2	RESERVED	0	00
179	B3	RESERVED	0	00
180	B4	RESERVED	0	00
181	B5	RESERVED	0	00
182	B6	RESERVED	0	00
183	B7	RESERVED	0	00
184	B8	RESERVED	0	00
185	B9	PAD (reserved), Default value is 0.	0	00
186	BA		0	00
187	BB		0	00
188	BC		0	00
189	BD		0	00
190	BE		0	00
191	BF		0	00
192	C0		0	00
193	C1		0	00
194	C2		0	00
195	C3		0	00
196	C4		0	00
197	C5		0	00
198	C6		0	00
199	C7		0	00
200	C8		0	00

Technical Reference Note

DS1100SLPE-3 FRU (EEPROM) Data:

OFFSET		DEFINITION	SPEC VALUE	
(DEC)	(HEX)	(REMARKS)	(DEC)	(HEX)
201	C9		0	00
202	CA		0	00
203	CB		0	00
204	CC		0	00
205	CD		0	00
206	CE		0	00
207	CF		0	00
208	D0		0	00
209	D1		0	00
210	D2		0	00
211	D3		0	00
212	D4		0	00
213	D5		0	00
INTERNAL USE AREA, 40 BYTES				
214	D6	RESERVED, Default value is 0.	0	00
215	D7		0	00
216	D8		0	00
217	D9		0	00
218	DA		0	00
219	DB		0	00
220	DC		0	00
221	DD		0	00
222	DE		0	00
223	DF		0	00
224	E0		0	00
225	E1		0	00
226	E2		0	00
227	E3		0	00
228	E4		0	00
229	E5		0	00
230	E6		0	00
231	E7		0	00
232	E8		0	00
233	E9		0	00
234	EA		0	00
235	EB		0	00
236	EC		0	00
237	ED		0	00
238	EE		0	00
239	EF		0	00
240	F0		0	00
241	F1		0	00
242	F2		0	00
243	F3		0	00
244	F4		0	00
245	F5		0	00
246	F6		0	00
247	F7		0	00
248	F8		0	00
249	F9		0	00
250	FA		0	00
251	FB		0	00
252	FC		0	00
253	FD		0	00
254	FE		0	00
255	FF	Zero CHECKSUM of Internal Use Area (if used). Default Value=0	0	00

PMBus™ Interface Support

The DS1100SLPE-3 is compliant with the industry standard PMBus™ protocol for monitoring and control of the power supply via the I²C interface port.

DS1100SLPE-3 Series PMBus™ General Instructions

Equipment Setup

The following is typical I²C communication setup:

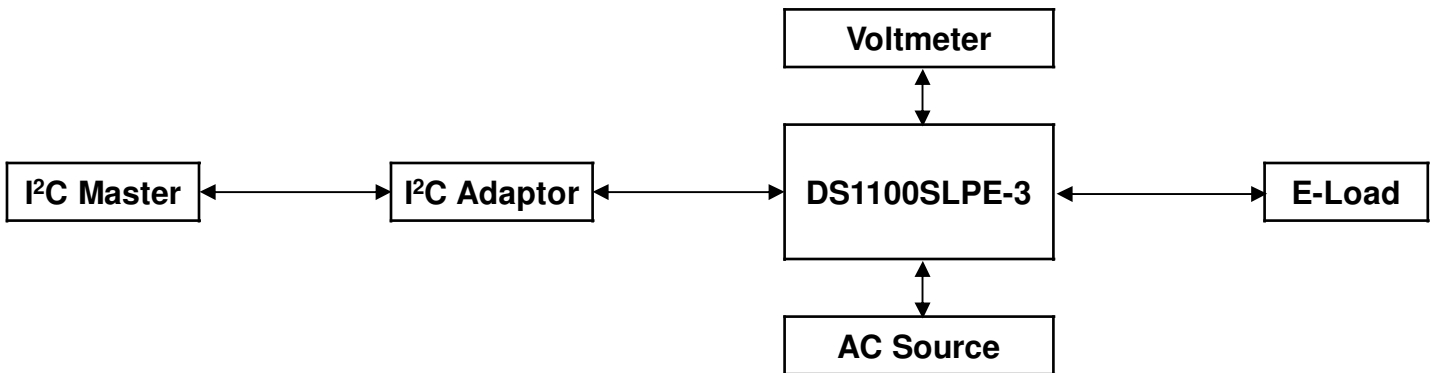

PMBus™ Writing Instructions

When writing to any PMBus™ R/W registers, ALWAYS do the following:

Disable Write Protect (command 10h) by writing any of the following accordingly:

- Levels: 00h - Enable writing to all writeable commands
- 20h - Disables write except 10h, 01h, 00h, 02h and 21h commands
- 40h - Disables write except 10h, 01h, and 00h commands
- 80h - Disable write except 0x00h

To save changes on the USER PMBus™ Table:

Use send byte command: 15h STORE_USER_ALL

To save changes on the DEFAULT PMBus™ Table:

Use send byte command: 11h STORE_DEFAULT_ALL

Wait for 5 seconds, turn-off the PSU, wait for another 5 seconds before turning it on.

DS1100SLPE-3 Series Support PMBus™ Command List

The DS1100SLPE-3 is compliant with the industry standard PMBus™ protocol for monitoring and control of the power supply via the I²C interface port.

DS1100SLPE-3 Series Supported PMBus™ Command List:

Command Code	Command Name	Default Value	Access Type	Data Bytes	Data Format	Description
00h	Page	00	R	1		
01h	OPERATION	80	R/W	1		Used to Turn the unit ON/OFF in conjunction with the input CONTROL pin. It is also used to set output to upper or lower Margin Voltages. Valid input: 80h, 40h
	b7:6	10				00 - Invalid Input 01 - Soft Turn OFF (With Sequencing) 10 - PSU ON 11 - Invalid Input
	b5:4	00				00 - VALID INPUT (Default) 01 - Margin Low 10 - Margin High
	b3:2	00				00 - VALID INPUT (Default)
	b1:0	00				00 - VALID INPUT (Default)
02h	ON_OFF_CONFIG	1D	R	1		Configures the combination of CONTROL pin and serial communication commands needed to turn the Unit ON/OFF.
	b7:5	00				Reserved
	b4 - Enable CONTROL pin and Serial communication control.	1				1 - Unit powers up as dictated by CONTROL pin and OPERATION command (b3:0)
	b3 - Serial communication Control	1				1 - Enables Serial communication ON/OFF portion of OPERATION command. Requires CONTROL pin to be asserted for the unit to start and energize the output.
	b2 - Sets how the unit responds to CONTROL pin	1				1 - Unit requires CONTROL pin to be asserted to start the unit.
	b1 - CONTROL pin polarity	0				0 - Active Low (Pull Low to start the unit)
	b0 - CONTROL pin Action	0				0 - Use programmed turn ON/OFF delay
03h	CLEAR_FAULTS		S	0		
10h	WRITE_PROTECT	80	R/W	1		Used to Control Writing to the PMBus Device.
19h	CAPABILITY	90	R	1		Provides a way for the hosts system to determine some key capabilities of a PMBus device.
1Ah	QUERY		BW/BR	1/1		Varies
20h	VOUT_MODE	17	R	1		Specifies the mode and parameters of Output Voltage related Data Formats
21h	VOUT_COMMAND	1800	R/W	2	Linear	Sets the Output Voltage Reference Vout command sends discreet value to change or trim output voltage. Valid range is 11.4 to 12.6V.
24h	VOUT_MAX	1933	R	2	Linear	Read Only (12.6V)
31h	POUT_MAX	0A71	R	2/5		Default : 1250W
35h	VIN_ON	0058	R	2	Linear	Sets the value of input, in volts, at which the unit should start. ACGOOD 88Vdc
36h	VIN_OFF	004F	R	2	Linear	Sets the value of input, in volts, at which the unit should stop power conversion. ACBAD 79Vac

DS1100SLPE-3 Series Supported PMBus™ Command List:

Command Code	Command Name	Default Value	Access Type	Data Bytes	Data Format	Description
3Ah	FAN_CONFIG_1_2	90	R	1		Read only to reflect setting of Fans
	b7	1				1 - Fan is installed in position 1 0 - No Fan is installed in position 1
	b6	0				1 - Fan is commanded in RPM 0 - Fan is commanded in DC
	b5:4	01				00 - 1 pulse per revolution 01 - 2 pulses per revolution 10 - 3 pulses per revolution 11 - 4 pulses per revolution
	b3	0				1 - Fan is installed in position 2 0 - No Fan is installed in position 2
	b2	0				1 - Fan is commanded in RPM 0 - Fan is commanded in DC
	b1:0	00				00 - 1 pulse per revolution 01 - 2 pulses per revolution 10 - 3 pulses per revolution 11 - 4 pulses per revolution
3Bh	FAN_COMMAND_1	0000	R/W	2	Linear	Adjusts the operation of the Fans. The device may override the command, if it requires higher value, to maintain proper device temperature. Default: 0%. Valid Range: 0- 100%.
40h	VOUT_OV_FAULT_LIMIT	1A66	R/W	2	Linear	Sets Output Over voltage threshold. (13.2V) Valid Range: 13.2V to 14.5V
41h	VOUT_OV_FAULT_RESPONSE	80	R	1		Unit Latches OFF. Resets on PSON or CONTROL pin recycle or DC recycle.
42h	VOUT_OV_WARN_LIMIT	1999	R/W	2	Linear	Sets Over-voltage Warning threshold. (12.8V) Valid Range: 12.5 to 13.5V
43h	VOUT_UV_WARN_LIMIT	1666	R/W	2	Linear	Sets Under-voltage Warning threshold. (11.2V) Valid Range: 10.5 to 11.5V
44h	VOUT_UV_FAULT_LIMIT	1333	R/W	2	Linear	Sets Under-voltage Fault threshold. (9.6V) Valid Range: 9.5 to 11.5V
45h	VOUT_UV_FAULT_RESPONSE	80	R	1		Turn PSU OFF. Delay time between restart attempts is 3 seconds.
46h	IOUT_OC_FAULT_LIMIT	EB60	R/W	2	Linear	Sets the Over current threshold in Amps. (108A) Valid Range: 97 to 108A
47h	IOUT_OC_FAULT_RESPONSE	C0	R	1		OCP ride through. If OCP persists. Delay time between restart attempts is 2 seconds.
4Ah	IOUT_OC_WARN_LIMIT	EB20	R/W	2	Linear	Sets the Over Current Warning threshold in Amps. (100A) Valid Range: 94 to 100A
4Fh	OT_FAULT_LIMIT	EB48	R/W	2	Linear	Secondary ambient temperature Fault threshold, in degree C. (105degC)
50h	OT_FAULT_RESPONSE	F8	R	1		Turn PSU OFF and will retry indefinitely. Supported enable/disable of protection and recoverability.
51h	OT_WARN_LIMIT	EB20	R	2	Linear	Secondary ambient temperature warning threshold, in degree C. Operating limit (100degC)
5Eh	PWGOOD_ON	1766	R/W	2	Linear	Sets the threshold by which the Power Good Default: 11.7V
5Fh	PWGOOD_OFF	16CC	R/W	2	Linear	Sets the threshold by which the Power Good Default: 11.4V
61h	TON_RISE	8BD7	R	2	Linear	Sets the time (mS), for the output rises from 0 to regulation. Default=30ms

DS1100SLPE-3 Series Supported PMBus™ Command List:

Command Code	Command Name	Default Value	Access Type	Data Bytes	Data Format	Description
64h	TOFF_DELAY	C280	R	2	Linear	Sets the time (mS), from a stop condition (Power OFF) until the output starts to drop (converter OFF). Default: 2.5mS
78h	STATUS_BYTE	00	R	1		Returns the summary of critical faults
	b7 - BUSY	-				Not supported
	b6 - OFF	-				Unit is OFF
	b5 - VOUT_OV	-				Output over-voltage fault has occurred
	b4 - IOUT_OC	-				Output over-current fault has occurred
	b3 - VIN_UV	-				An input under-voltage fault has occurred
	b2 - TEMPERATURE	-				A temperature fault or warning has occurred
	b1 - CML	-				A communication, memory or logic fault has occurred.
	b0 - NONE OF THE ABOVE	-				A Fault Warning not listed in bits[7:1] has occurred. Not supported
79h	STATUS_WORD	0000	R	2		Summary of units Fault and warning status.
	b15 - VOUT					An output voltage fault or warning has occurred
	b14 - IOUT/POUT					An Output current or power fault or warning has occurred.
	b13 - INPUT					An input voltage, current or power fault or warning as occurred.
	b12 - MFR					A manufacturer specific fault or warning has occurred. Not supported
	b11 - PWOK#					The PWOK signal is de-asserted
	b10 - FANS					A fan or airflow fault or warning has occurred.
	b9 - OTHER					Not supported
	b8 - UNKNOWN					Not supported
	b7 - BUSY					A fault was declared because the device was busy and unable to respond. Not supported
	b6 - OFF					Unit is OFF
	b5 - VOUT_OV					Output over-voltage fault has occurred
	b4 - IOUT_OC					Output over-current fault has occurred
	b3 - VIN_UV					An input under-voltage fault has occurred
	b2 - TEMPERATURE					A temperature fault or warning has occurred
	b1 - CML					A communication, memory or logic fault has occurred.
	b0 - NONE_OF_THE_ABOVE					A fault or warning not listed in bits[7:1] of this byte has occurred. Not supported
7Ah	STATUS_VOUT	00	R	1		Output voltage related faults and warnings
	b7					VOUT Over-voltage Fault
	b6					VOUT Over-voltage warning
	b5					VOUT Under-voltage Warning
	b4					VOUT Under-voltage Fault
	b3					VOUT_MAX Warning, an attempt has been made to set output to a value higher than the highest permissible voltage. Not supported
	b2					TON_MAX_FAULT. Not supported
	b1					TOFF_MAX Warning. Not supported
	b0					Not supported.

DS1100SLPE-3 Series Supported PMBus™ Command List:

Command Code	Command Name	Default Value	Access Type	Data Bytes	Data Format	Description
7Bh	STATUS_IOUT	00	R	1		Output Current related faults and warnings
	b7					IOUT Over current Fault
	b6					IOUT Over current And Low Voltage shutdown Fault. Not supported
	b5					IOUT Over current Warning
	b4					IOUT Under current Fault. Not supported
	b3					Current Share Fault. Not supported
	b2					Power Limiting. Not supported
	b1					POUT Over power Fault. Not supported
	b0					POUT Over power Warning. Not supported
7Ch	STATUS_INPUT		R	1		Input related faults and warnings
	b7					VIN Over voltage Fault
	b6					VIN Over voltage Warning
	b5					VIN Under voltage Warning
	b4					VIN Under voltage Fault
	b3					Unit is OFF for insufficient Input Voltage (not UV)
	b2					IIN Over current Fault. Not supported
	b1					IIN Over current Warning. Not supported
	b0					PIN Over power Warning. Not supported
7Dh	STATUS_TEMPERATURE	00	R	1		Temperature related faults and warnings
	b7					Over temperature Fault
	b6					Over temperature Warning
	b5					Under temperature Warning . Not supported
	b4					Under temperature Fault . Not supported
	b3:0					Reserved
7Eh	STATUS_CML	00	R	1		Communications, Logic and Memory
	b7					Invalid or unsupported Command Received. The following conditions will also assert this flag: -A write transaction on read only commands. -A write transaction on a password protected command that is still locked .
	b6					Invalid Data
	b5					Packet Error Check Failed
	b4					Memory Fault Detect, CRC Error Not Supported
	b3					Not Supported
	b2					Not Supported
	b1					A communication fault other than the ones listed in this table has Occurred.
b0					Not Supported	

DS1100SLPE-3 Series Supported PMBus™ Command List:

Command Code	Command Name	Default Value	Access Type	Data Bytes	Data Format	Description
81h	STATUS_FANS_1_2	00	R	1		
	b7					Fan 1 Fault
	b6					Fan 2 Fault. Not supported
	b5					Fan 1 Warning
	b4					Fan 2 Warning. Not supported
	b3					Fan_1 Speed Overridden
	b2					Fan_2 Speed Overridden. Not supported
	b1					Not supported
b0					Not supported	
88h	READ_VIN	-	R	2	Linear	Returns input Voltage in Volts.
89h	READ_IIN	-	R	2	Linear	Returns input Current in Amperes
8Bh	READ_VOUT	-	R	2	Linear	Returns the actual, measured voltage in Volts.
8Ch	READ_IOUT	-	R	2	Linear	Returns the output current in amperes.
8Dh	READ_TEMPERATURE_1	-	R	2	Linear	PSU's inter hot spot temperature typically that of the main output rail heat sink. Secondary Ambient /-3 Primary Ambient /-3-001
8Eh	READ_TEMPERATURE_2	-	R	2	Linear	PSU's system-side air inlet or internal ambient temperature . Primary Hot-sink / -3 Secondary Hot-sink /-3-001
8Fh	READ_TEMPERATURE_3	-	R	2	Linear	PSU's chassis-side air exhaust temperature. Primary Ambient / -3 Secondary Ambient /-3-001
90h	READ_FAN_SPEED_1	-	R	2	Linear	Speed of Fan 1
96h	READ_POUT	-	R	2	Linear	Returns the output power, in Watts.
97h	READ_PIN	-	R	2	Linear	Returns the input power, in Watts.
98h	PMBUS_REVISION	11	R	1	Linear	Reads the PMBus revision number
	b7:5	0001				Part 1 Revision 0000 - Revision 1.0 0001 - Revision 1.1
	b4:0	0001				Part 2 Revision 0000 - Revision 1.0 0001 - Revision 1.1
99h	MFR_ID	"ARTESYN"	BR	7	ASCII	Abbrev or symbol of manufacturers name.
9Ah	MFR_MODEL	"DS1100SLPE-3"	BR	16	ASCII	Manufacturers Model number Default:"DS1100SLPE-3"/"DS1100SLPE-3-001"
9Bh	MFR_REVISION	"0x0, 0x0,0x0 "	BR	3	ASCII	Manufacturers, revision number
9Ch	MFR_LOCATION	"Zhongshan"	BR	12	ASCII	Manufacturers facility Default: 'Zhongshan'= 0x5A, 0x68,0x6F,0x6E, 0x67,0x73, 0x68, 0x61,0x6E, 0x0, 0x0,0x0
9Dh	MFR_Date	"YYMMDD"	BR	7	ASCII	Manufacture Date Default: 'YYMMDD' = 0x59, 0x59,0x4D, 0x4D, 0x44,0x44,0x0
9Eh	MFR_DATE	"K543WWSSSSR RP"	BR	16	ASCII	Unit serial numberDefault: 'K543WWSSSSRRP'= 0x4B, 0x35,0x34, 0x33, 0x57,0x57, 0x53, 0x53,0x53, 0x53, 0x52,0x52, 0x50, 0x0,0x0, 0x0

DS1100SLPE-3 Series Supported PMBus™ Command List:

Command Code	Command Name	Default Value	Access Type	Data Bytes	Data Format	
A0h	MFR_VIN_MIN	005A	R	2	Linear	Minimum Input Voltage (90Vdc)
A1h	MFR_VIN_MAX	0108	R	2	Linear	Maximum Input Voltage (264Vdc)
A2h	MFR_IIN_MAX	F81D	R	2	Linear	Maximum Input Current (14.5A)
A3h	MFR_PIN_MAX	0A71	R	2	Linear	Maximum Input Power (1250W)
A4h	MFR_VOUT_MIN	16CC	R	2	Linear	Minimum Output Voltage Regulation Window. (11.4V)
A5h	MFR_VOUT_MAX	1933	R	2	Linear	Maximum Output Voltage. Regulation Window (12.6V)
A6h	MFR_IOUT_MAX	005A	R	2	Linear	Maximum Output Current (90A)
A7h	MFR_POUT_MAX	0A26	R	2	Linear	Maximum Output Power (1100W)
A8h	MFR_TAMBIENT_MAX	0037	R	2	Linear	Maximum Operating Ambient Temperature (Secondary Ambient) (55degC)
A9h	MFR_TAMBIENT_MIN	0000	R	2	Linear	Minimum Operating Ambient Temperature (Secondary Ambient) (0degC)
AAh	MFR_EFFICIENCY_LL		BR	14		Default: 115V, 220W, 90%, 550W, 92%, 1100W, 89%
ABh	MFR_EFFICIENCY_HL		BR	14		Default: 230V, 220W, 90%, 550W, 94%, 1100W, 91%
D2h	FAN_SPEED_MIN	2177	R	2	Linear	Minimum Fan Speed (6000 RPM)
D3h	FAN_SPEED_MAX	3168	R	2	Linear	Maximum Fan Speed (23000 RPM)
E0h	FW_PRI_VERSION		BR	8	ASCII	
E1h	FW_SEC_VERSION		BR	8	ASCII	
F5h	ISP_UNLOCK_CODE		BW	4	ASCII	00h,00h,00h,00h
F6h	ISP_CTRL_CMD		W	1		
F7h	ISP_STATUS_BYTE		R	1		
F9h	ISP_FLASH_DATA.		BR/W	16		

Application Notes

Redundancy / Fault Tolerance

The DS1100SLPE-3 series power supplies must be able to current share with 2(1+1) up to 6(3+3) power supplies in parallel and operate in a hot swap/redundant N+N configuration where N=1, 2, or 3. The 3.3V V_{SB} outputs of the power supplies are connected together in the system so that a failure or hot swap of a redundant power supply does not cause these outputs to go out of regulation in the system.

All power supply outputs will be designed for redundant mode operation. No internal failure in any power supply in this configuration should cause the bus voltage to fall below the regulation limits specified. All output voltages should stay within the regulation limits during cold swapping or hot swapping operation.

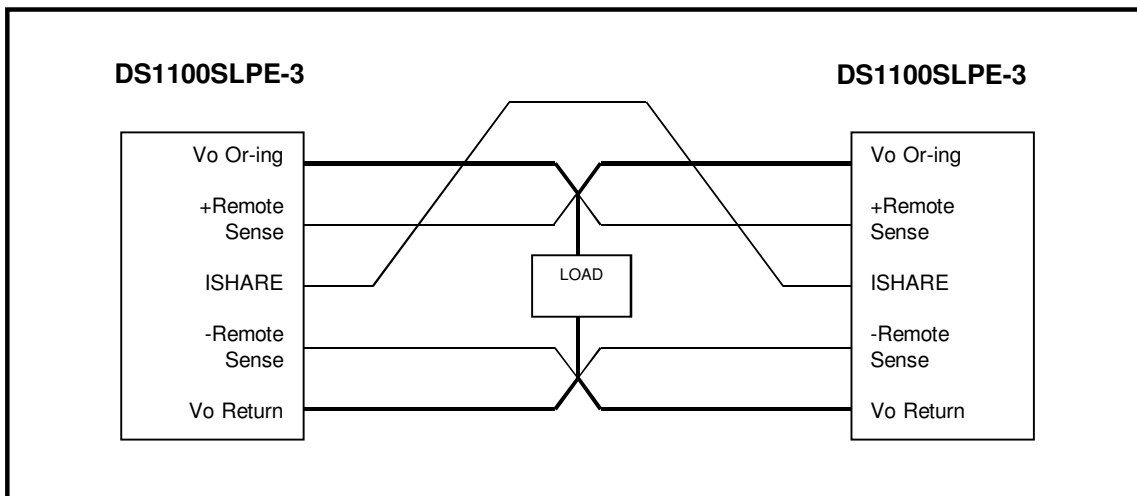

Current Sharing

The DS1100SLPE-3 series' main output V_O is equipped with current sharing capability. Single wire master-slave forced current share will be employed in this power supply. When two or more power supplies are connected and operating in parallel, the sharing accuracy between units must be within the limits specified in the table below.

Table 13. Current Sharing Accuracy

Load (per power supply unit)	Max Difference between PSUs
20%-100%	5.625A
<20%	5.625A

The current sharing function may start when the total system load has reached 7% of the power supply rating. The power supply should be tested to support up to 6 units in parallel, with each power supply delivering 100% load. The current share signal, I_{mon} , is a DC signal that represents the load current that a power supply is providing. This voltage will increase proportionately with the output load and will be represented by $8 \cdot I_{out}/I_{max}$. The I_{share} voltage should be within the voltage range specified below. It should be capable of sinking 0.4mA and sourcing 4mA. The waveform for this signal will be provided to confirm stability during parallel mode operation.

Table 14. I_{mon} Signal Accuracy

Load (per power supply unit)	Min	Typ	Max
100%	7.75	8	8.25
50%	3.85	4	4.15
10%	0.6	0.8	1.0

The current share signal may be disabled by shorting this pin to ground. The main output voltage should stay within regulation limits in this condition.

Output Ripple and Noise Measurement

The setup outlined in the diagram below has been used for output voltage ripple and noise measurements on the DS1100SLPE-3 Series. When measuring output ripple and noise, a scope jack in parallel with a 0.1uF ceramic chip capacitor, and a 10uF aluminum electrolytic capacitor should be used. Oscilloscope should be set to 20MHz bandwidth for this measurement.

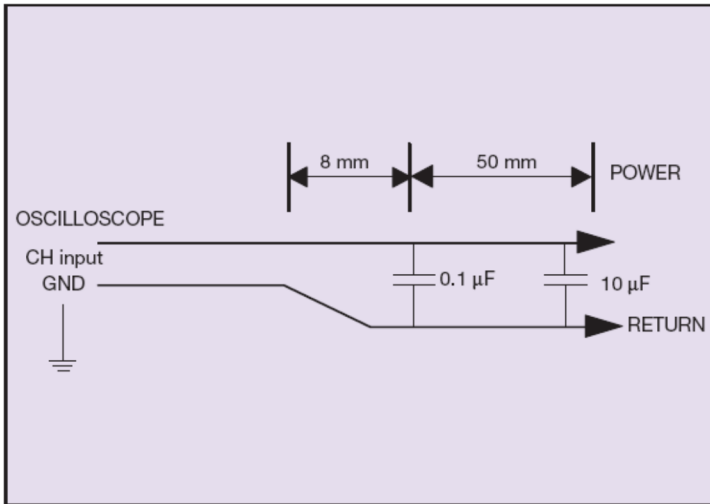

Record of Revision and Changes

Issue	Date	Description	Originators
1.0	10.12.2016	First Issue	K. Zou
1.1	05.04.2017	Update the SCL/SDA internal pull up resistor Update the PWOK and ACOK internal pull up resistor Update the -6dB as typical rather than minimum.	K. Wang
1.2	07.05.2017	Updated Table 3 Dynamic load and total range; added note on no load operation; updated standby ripple; added AC Input Sag and Surge	K. Zou
1.3	12.03.2017	Add minimum airflow definition in page 22.	B. Wang
1.4	09.04.2018	Update Isolation Voltage according to CB report	K. Zou
1.5	12.27.2018	1.Update the parallel number to 6 2.Command list 31h, 51h,64h	K. Wang
1.6	07.12.2019	Update the 40h valid range to 13.2 to 14.5V	K. Wang
1.7	06.18.2020	Update safety 60950 to 62368	K. Zou

WORLDWIDE OFFICES

Americas

2900 South Diablo Way
Suite B100
Tempe, AZ 85282
USA
+1 888 412 7832

Europe (UK)

Ground Floor Offices
Barberry House, 4 Harbour Buildings
Waterfront West, Brierley Hill
West Midlands, DY5 1LN, UK
+44 (0) 1384 842 211

Asia (HK)

14/F, Lu Plaza
2 Wing Yip Street
Kwun Tong, Kowloon
Hong Kong
+852 2176 3333

ARTESYNTM
An Advanced Energy Company
www.artesyn.com

Artesyn Embedded Technologies, Artesyn Embedded Power, Artesyn, and all Artesyn related logos are trademarks and service marks of Artesyn Embedded Technologies, Inc. All other names and logos referred to are trade names, trademarks, or registered trademarks of their respective owners. Specifications are subject to change without notice. © 2019 Artesyn Embedded Technologies, Inc. All rights reserved. For full legal terms and conditions, please visit www.artesyn.com/legal.

For more information: www.artesyn.com
For support: productsupport.ep@artesyn.com

Mouser Electronics

Authorized Distributor

Click to View Pricing, Inventory, Delivery & Lifecycle Information:

[Advanced Energy:](#)

[DS1100SLPE-3](#) [DS1100SLPE-3-001](#)