

Angle Position Sensors

AS500106

Magnet carrier for use with Angle Position Sensors



Features

- PPS housing
- Samarium Cobalt 28 magnet
- RoHS compliant

Environmental Specifications

Vibration	15g sinusoidal, 9.26g RMS axial; 40 Hz – 2 kHz all 3 axes
Operation Temperature	-40 °C to 125 °C (-40 °F to 257 °F)
Storage Temperature	-40 °C to 150 °C (-40 °F to 302 °F)
Salt Spray	SAEJ1455, Section 4.3.3
Immersion	Tested per SAE J 1455, Section 4.4.1: Engine oil and additives, Transmission oils, Water, Power steering fluid, Brake fluids, Washer solvent, Gasoline, Diesel fuel, Alcohol, Antifreeze water mixture, Battery acid, Salt water, Kerosene, Ammonia

Mechanical Specifications

Recommended Fastener	M4 Cap Screw
Recommended Torque	3 Nm (26.5 in lbs)

Products

Part Number	Description	Sensing Range
AS500106	Magnet only	N/A
CU103601	Kit with AN820001 sensor	180°
CU103602	Kit with AN820002 sensor	360°
CU103603	Kit with AN820003 sensor	45°

Dimensions mm (inches)

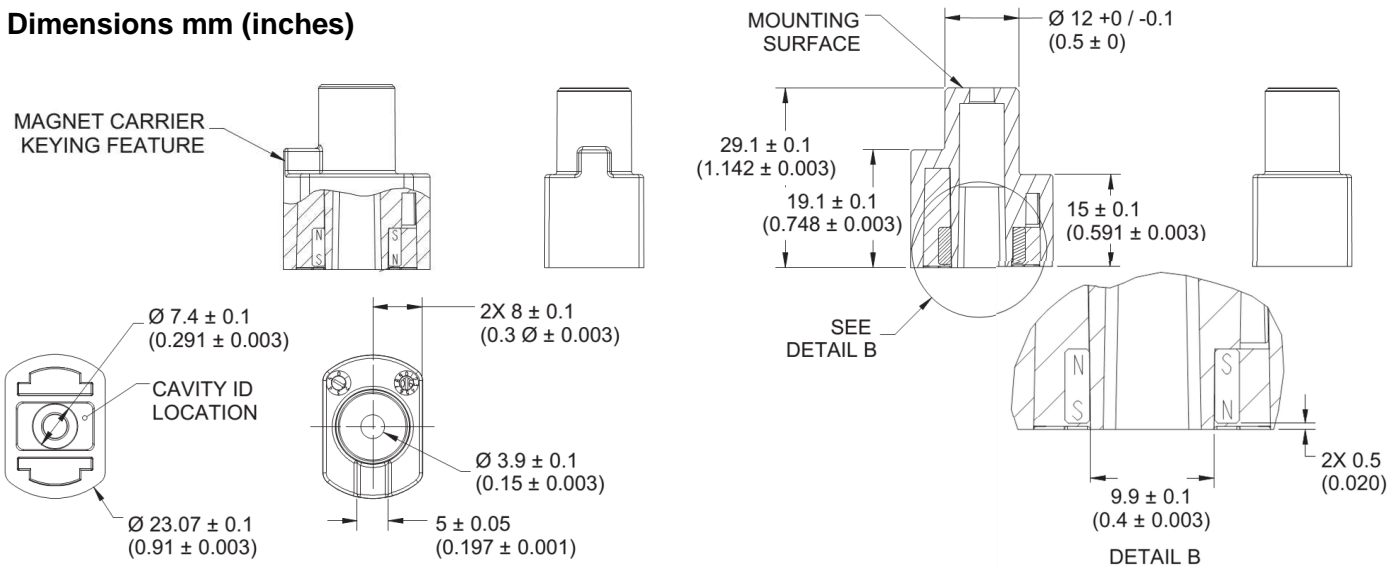

www.switches-sensors.zf.com ZF Electronics Systems Pleasant Prairie, LLC ("ZF") acquired the rights to the CHERRY branded switches and sensors in 2008. Although ZF divested its interest in the CHERRY name in 2015, the switches and sensors remain unchanged and are now sold under the ZF brand.



Mouser Electronics

Authorized Distributor

Click to View Pricing, Inventory, Delivery & Lifecycle Information:

[ZF Electronics:](#)

[CU103602](#) [CU103601](#) [CU103603](#) [AS500106](#)