

# 43R Servo(360° Rotation) Specification

*Thank you for choosing Spring Model's product*

MODEL	TYPE	WEIGHT		4.8V			6V			DESCRIPTION	
		g	oz	SPEED	TORQUE		SPEED	TORQUE		GEAR	BEARING
				r/min	kg.cm	oz.in	r/min	kg.cm	oz.in		
SM-S4303R	Analog	44	1.55	60	3.3	45.8	70	4.8	66.7	1Metal Gear+ 4Plastic Gear	2
SM-S4306R		44	1.55	60	5.0	69.4	50	6.2	86.1	1Metal Gear+ 4Plastic Gear	2
SM-S4309R		60	2.12	58	7.9	109.7	49	8.7	120.8	Metal Gear	2
SM-S4315R		60	2.12	62	14.5	201.4	53	15.4	213.9	Metal Gear	2

- ▲ 43R Robot series servo controled via analog signal(PWM),stopped via middle point positiner.
- ▲ Standard interface(like JR)with 30cm wire.
- ▲ Rotation and Rest Point Adjustment:when analog signal inputs,servo chooses orientation according to impulse width.when intermediatevalue of impluse width is above 1.5ms, servo is clockwise rotation,conversely,anticlockwise.Rest point need use slotted screwdriver to adjust the positioner carefully.Servo stopped rotation when the input signal is equivalent to impluse width.
- ▲ Please choose correct model for your application.  
Caution: Torque over-loaded will damage the servo's mechanism.
- ▲ Keep the servo clean and away from dust, corrosive gas and humid air.
- ▲ Without further notification when some parameters slightly amend for improving quality.

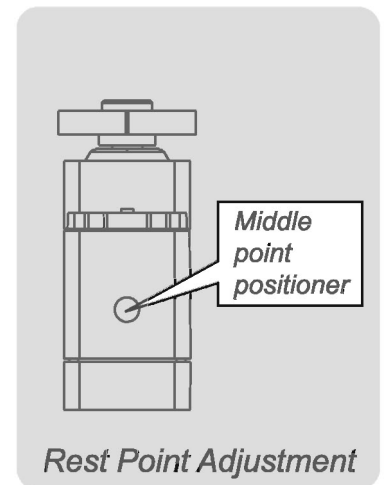
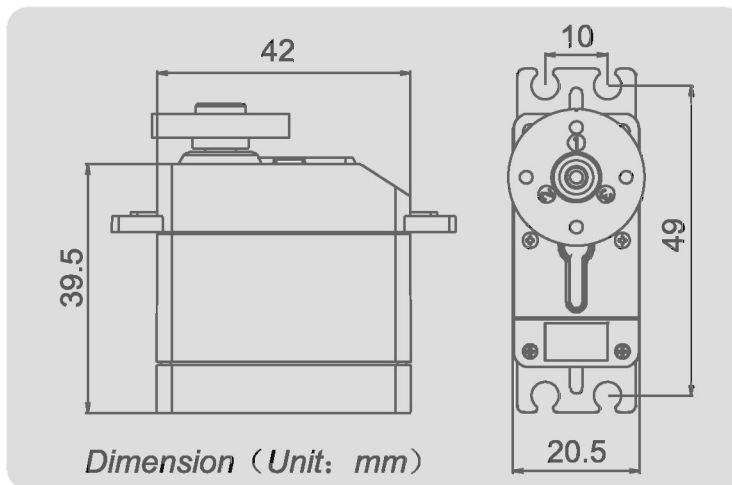
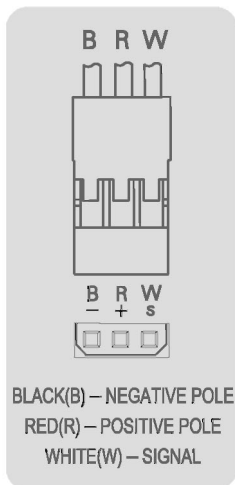

# Mouser Electronics

Authorized Distributor

Click to View Pricing, Inventory, Delivery & Lifecycle Information:

[SparkFun Electronics:](#)

[ROB-09347](#)