



LUMILEDS LUXEON CZ Starboards

Industry Leading High Powered LED Starboards

Data Sheet

Version 1.0

Lean & Fast. Made Smarter.

Superior Performance - Stay current with the highest intensity LEDs

Design Faster - Use industry standard starboards to shorten development time

Maximum Flexibility - Design to your exact specifications using the full spectrum of Opulent Americas' starboards

Rapid Innovation - Work with Opulent Americas on your custom solution

Primary Applications



Architectural
Emergency Vehicle
Downlight



Stage/concert
Spot lighting
Floodlight

Superior Performance with Flexible Options

- Multiple color options for your application
- Single focal length for all colors to ensure superior mixing
- Small source size reduces the size of secondary optics
- Prototype faster, test multiple options

Custom Solutions

Opulent Americas operates facilities globally with ISO certifications for the LED lighting, automotive and medical industries. Our North Carolina based office provides quick engineering & sales support with an R&D lab for prototype development and custom solutions. Our in-house global manufacturing capabilities allow for both building in the United States as well as overseas at scale.



About Opulent Americas

Opulent Americas accelerates the adoption of LED technology through simple, modular products and custom designs. Through 30 years of experience, state of the art manufacturing, full traceability and advanced quality controls, Opulent offers leading solid state lighting components, modules and custom solutions. Opulent customers get to market faster, with less resources, at lower costs. Visit opulent-americas.com for more information.

LUMILEDS LUXEON CZ Starboards

Product Selection Guide

Part Number	CRI/Color	CCT/ Typical Peak Wavelength Range	Typical Viewing Angle	Typical Luminous Flux (mW)	Typical Forward Voltage (Vf)	Typical Wattage (W)
LST1-01H07-RED1-01	Red	624-634	120°	31	2.00	0.70
LST1-01H07-PCA1-01	Amber	n/a ⁽²⁾	120°	78	2.75	0.96
LST1-01H07-LME1-01	Lime	n/a ⁽²⁾	120°	122	2.75	0.96
LST1-01H07-GRN1-01	Green	520-540	120°	117	3.05	1.07
LST1-01H07-BLU1-01	Blue	465-485	120°	34	2.83	0.99
LST1-01H07-3080-01	80	3000K	120°	95	2.75	0.96

⁽¹⁾Flux, wavelength, and wattage values specified at 350mA, T_j 85°C

⁽²⁾Amber and Lime starboards are binned by chromaticity coordinates, see LUMILEDS LED datasheet for values.

All values shown above are typical.

Additional colors available upon request.

Maximum Ratings

Part Number	DC Current (A)	Tsp Temp (°C)	Power (W)
LST1-01H07-RED1-01	1.05	105	2.6
LST1-01H07-PCA1-01	1.05	105	3.7
LST1-01H07-LME1-01	1.23	105	4.3
LST1-01H07-GRN1-01	1.05	105	3.7
LST1-01H07-BLU1-01	1.05	105	3.7
LST1-01H07-3080-01	1.23	105	4.3

Mechanical Dimensions

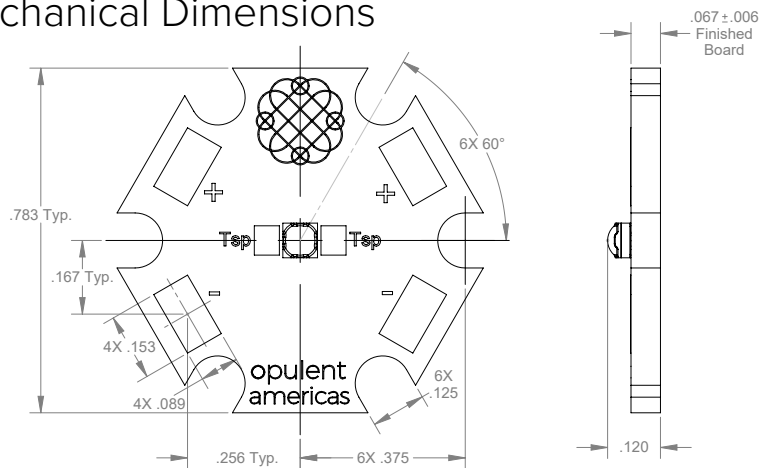

Mouser Electronics

Authorized Distributor

Click to View Pricing, Inventory, Delivery & Lifecycle Information:

New Energy:

[LST1-01H07-PCA1-01](#) [LST1-01H07-GRN1-01](#) [LST1-01H07-BLU1-01](#) [LST1-01H07-LME1-01](#) [LST1-01H07-RED1-01](#)
[LST1-01H07-3080-01](#)