

**NOTES:**

1. FOR WAVESOLDERING (SOLDER BATH TEMPERATURE 260 °C FOR 5 SEC. AND SOLDER PREHEAT 100 °C FOR 30 SEC.)
2. METALSHELLS: STEEL; min. 315µin TIN over 40-80µin NICKEL
3. INSULATOR: HIGH TEMPERATURE PLASTIC UL 94 V-0, BLACK
4. CONTACTS: COPPER ALLOY; PLATING (SEE PART NO.):
  - PLEASE ADD A for GOLD FLASH over NICKEL (PREFERRED TYPE)
  - PLEASE ADD B for 20µin HARD GOLD over min. 50µin NICKEL
  - PLEASE ADD C for 30µin HARD GOLD over min. 50µin NICKEL
- CONTACT TAILS PRETINNED
5. METAL BRACKETS: ZINC DIE CAST; 300µin COPPER/40-120µin NICKEL/120-200µin TIN
6. THREADED LOCKS: COPPER ALLOY; min. 200µin TIN over 80µin NICKEL
7. FIXING-PLATE: HIGH TEMPERATURE PLASTIC UL 94 V-0; BLACK
8. CAPACITANCE: 1300pF±20%
9. DIELECTRIC WITHSTANDING VOLTAGE: 424 VDC
10. P.C.B. HOLE DRILLINGS ON SHEET 2
11. MAXIMUM TORQUE VALUE FOR THREAD: 6 in.LB
12. CONNECTOR IS PART MARKED: 242□13490X CONEC ABC (see note 4)

RoHS compliant

THIS DRAWING MAY NOT BE COPIED OR REPRODUCED IN ANY WAY, AND MAY NOT BE PASSED ON TO A THIRD PARTY WITHOUT WRITTEN PERMISSION. OWNERSHIP AND COPYRIGHT OF CONEC GmbH DO NOT ALTER CAD DRAWING BY HAND					tolerance	dim. in mm	scale:	2:1 (5:1)		
								material:	SEE NOTES	
					date	name	title:			
					drawn	29.01.15	Henneboel	<b>D-SUB C-FILTER FEMALE 90°</b> 37pos. SOLDER PIN ANGLED 0.318inch threaded lock, metal bracket, fixing plate		
					appd.	29.01.15	Lehmenkühler			
					norm					
					d-old					
		a	Original					dwg no:	24K1A1568	DIN-A3
	rev.	description	date	name				part no:	242 □13490X (see note 4)	sh:1/2

# P.C.B. HOLE DRILLINGS

(P.C.B. TOP SIDE)

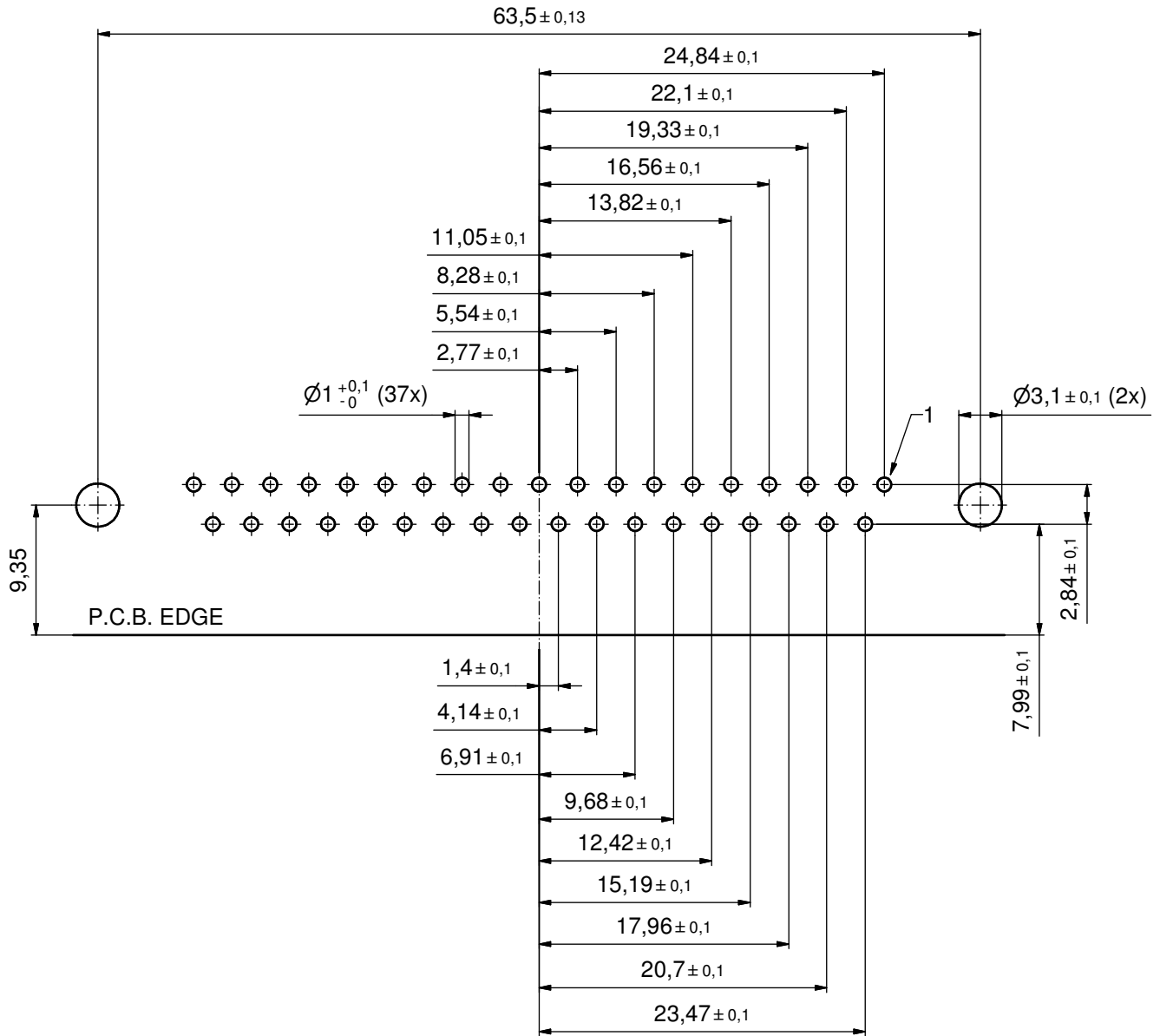

THIS DRAWING MAY NOT BE COPIED OR REPRODUCED IN ANY WAY, AND MAY NOT BE PASSED ON TO A THIRD PARTY WITHOUT WRITTEN PERMISSION. OWNERSHIP AND COPYRIGHT OF CONEC GmbH DO NOT ALTER CAD DRAWING BY HAND				tolerance		scale: 3:1
					dim. in mm	material: SEE SHEET 1
				date	name	title: <b>P.C.B. HOLE DRILLINGS</b> D-SUB C-FILTER FEMALE 90° 37pos. 0.318inch threaded lock, metal bracket, fixing plate
				drawn 29.01.15	Henneboel	
				appd. 29.01.15	Lehmenkühler	
				norm		dwg no:
				d-old		DIN-A3
a	Original		<b>CONEC</b> <sup>®</sup>		24K1A1568	sh:2/2
rev.	description	date			name	part no: SEE SHEET 1

# Mouser Electronics

Authorized Distributor

Click to View Pricing, Inventory, Delivery & Lifecycle Information:

[CONEC:](#)

[242A13490X](#)