

## DIO5508B

### 600mA Lithium Ion Battery Charger IC

#### Features

- Programmable Charge Current Up to 600mA
- Over Voltage Lockout Protection
- Under Voltage Lockout Protection
- Reverse current protection between BAT and GND pins
- Automatic Recharge Threshold 4.05V (Typ.)
- Charge Status Output Pin
- 2.9V Trickle Charge Threshold
- Soft-Start Limits Inrush Current
- Available in SOT23-6 package
- Pb-free, rohs-compliant and Halogen-free

#### Descriptions

The DIO5508B is a complete constant-current / constant voltage linear charger for single cell Lithium-Ion batteries. No external sense resistor is needed, and no blocking diode is required due to the internal MOSFET architecture. The charge voltage is fixed at 4.2V, and the charge current can be programmed externally with a single resistor.

The DIO5508B automatically terminates the charge cycle when the charge current drops to 1/10 the programmed value after the final float voltage is reached.

When the input supply (wall adapter or USB supply) is removed, the DIO5508B automatically enters a low current state, dropping the battery drain current to less than 0.5 $\mu$ A. The DIO5508B can be put into shutdown mode, reducing supply current to 40 $\mu$ A (Typ.).

The DIO5508B is available in SOT23-6 package.

#### Applications

- Wireless phone
- MP3/MP4 Player
- Bluetooth device

#### Typical Application Circuit

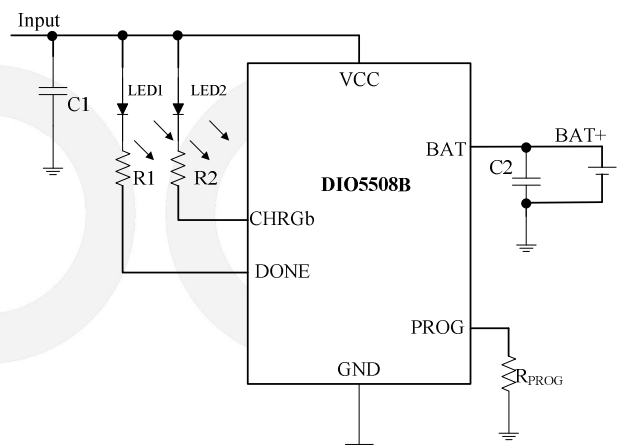

Figure 1 Typical Application Circuit

## Ordering Information

Order Part Number	Top Marking		T <sub>A</sub>	Package	
DIO5508BST6	W50B	Green	-40 to 85°C	SOT23-6	Tape & Reel, 3000

## Pin Assignment

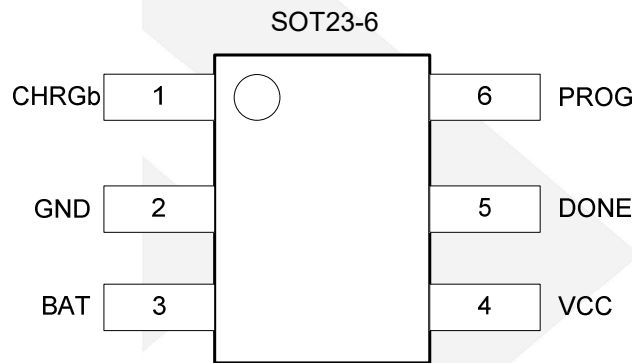

Figure 2 Pin Assignment

## Pin Descriptions

Pin No.	Name	Function Description
1	CHRGb	<b>Open-Drain Charge Status Output.</b> When the battery is charging, the CHARGb pin is pulled low. When the charge cycle is completed or VCC is removed, the CHARGb is forced high impedance.
2	GND	<b>Ground Terminal.</b>
3	BAT	<b>Battery Connection Pin.</b> Provides charge current to the battery and regulates the final float voltage to 4.2V.
4	VCC	<b>Power Supply.</b>
5	DONE	<b>Charge termination Status Output.</b> Open drain output. In charge termination status, DONE is pulled low by an internal switch; Otherwise DONE pin is in high impedance state.
6	PROG	<b>Charge current setting,</b> charge current monitor and shutdown pin. The charging current is given by $I_{BAT} = (1/R_{PROG}) * 1000$ . The chip will be shutdown when PROG pin floating.

Block Diagram

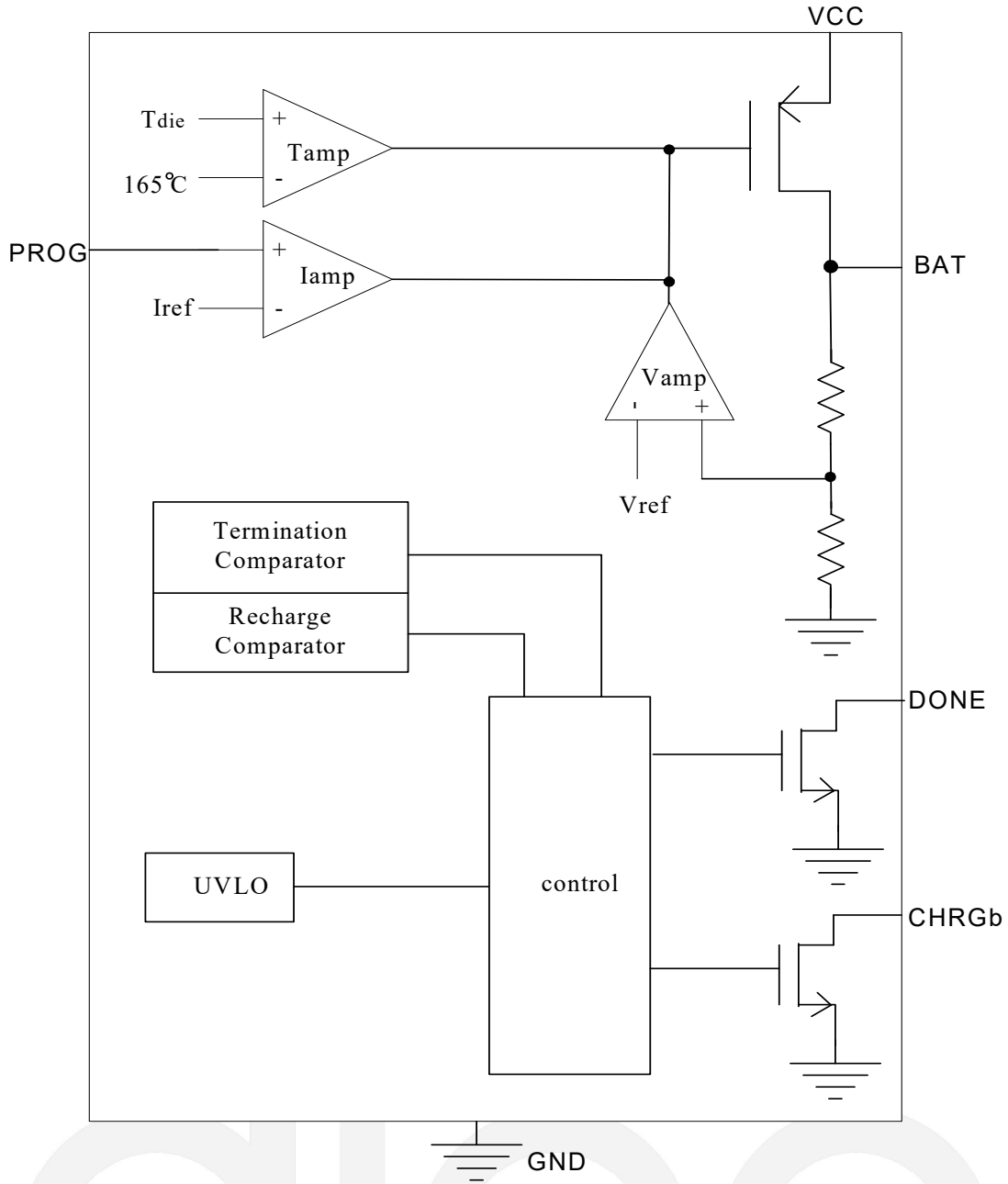

Figure 3 Block Diagram



# DIO5508B

600mA Lithium Ion Battery Charger IC

## Absolute Maximum Ratings

Stresses beyond those listed under “Absolute Maximum Rating” may cause permanent damage to the device. These are stress ratings only and functional operation of the device at these or any other condition beyond those indicated in the operational sections of the specifications is not implied. Exposure to absolute maxim rating conditions for extended periods may affect device reliability.

Parameter	Rating	Unit
Supply Voltage	-0.3~10	V
PROG Voltage	-0.3~VCC	V
BAT Voltage	-0.3~10	V
CHRGb, DONE Voltage	-0.3~VCC	V
BAT Pin Current	600	mA
Thermal Resistance, $R_{\theta JA}$	190	°C/W
Power Dissipation	0.6	W
Junction Temperature	150	°C
Operation Temperature	-45~85	°C
Storage Temperature	-65~125	°C
Lead Temperature (Soldering 10s)	260	°C

## Recommend Operating Conditions

The Recommended Operating Conditions table defines the conditions for actual device operation. Recommended Operating conditions are specified to ensure optimal performance to the datasheet specifications. DIOO does not Recommend exceeding them or designing to Absolute Maximum Ratings.

Parameter	Rating	Unit
Input Supply Voltage	4.5 to 5.5	V
Operating Temperature Range	-40 to 85	°C



# DIO5508B

600mA Lithium Ion Battery Charger IC

## Electrical Characteristics

VCC=5V, T<sub>A</sub> = -40 to 85°C, Typical values are measured at T<sub>A</sub> = 25°C, unless otherwise specified.

Symbol	Parameter	Conditions	Min.	Typ.	Max.	Unit
I <sub>ISOLYCHRG</sub>	Charge Mode Supply Current	R <sub>PROG</sub> =2kΩ		250	2000	μA
		R <sub>PROG</sub> =10kΩ		200	2000	μA
I <sub>BATCHRG</sub>	Charge Mode Battery Current	R <sub>PROG</sub> =2kΩ	450	500	550	mA
		R <sub>PROG</sub> =10kΩ	90	100	110	mA
V <sub>PROGCHRG</sub>	PROG Pin Voltage	R <sub>PROG</sub> =2kΩ	0.93	1.00	1.07	V
		R <sub>PROG</sub> =10kΩ	0.93	1.00	1.07	V
I <sub>SPLYSTBY</sub>	Standby Mode Supply Current	Charge Terminated		136	500	μA
I <sub>BATSTBY</sub>	Standby Mode Battery Current	Charge Terminated	0	-2.5	-6	μA
I <sub>SPLYASD</sub>	Shutdown Mode Supply Current	V <sub>CC</sub> <V <sub>BAT</sub>	20	42	90	μA
I <sub>BATASD</sub>	Shutdown Mode BAT Pin Current	V <sub>CC</sub> <V <sub>BAT</sub>		±0.05	±1	μA
I <sub>SPLYUVLO</sub>	UVLO Mode Supply Current	V <sub>CC</sub> <V <sub>UV</sub>	20	42	90	μA
I <sub>BATUVLO</sub>	UVLO Mode BAT Pin Current	V <sub>CC</sub> <V <sub>UV</sub>		±0.05	±1	μA
I <sub>SPLYOVLO</sub>	OVLO Mode Supply Current	V <sub>CC</sub> >V <sub>OV</sub>		40		μA
I <sub>BATOVLO</sub>	OVLO Mode BAT Pin Current	V <sub>CC</sub> >V <sub>OV</sub>		±0.05	±1	μA
I <sub>SPLYSHUT</sub>	Shutdown Mode Supply Current	R <sub>PROG</sub> not Connected	20	42	70	μA
I <sub>BATSHUT</sub>	Shutdown Mode BAT Pin Current	R <sub>PROG</sub> not Connected		±0.05	±1	μA
I <sub>BATMSD</sub>	Manual Shutdown BAT Pin Current	V <sub>PROG</sub> =1.3V		±0.05	±1	μA
I <sub>BATSLEEP</sub>	Sleep Mode BAT Pin Current	V <sub>CC</sub> =0V		±0.05	±1	μA
I <sub>Charge_terminated</sub>	600mA/50mA charger terminated	R <sub>PROG</sub> =2kΩ		50		μA
V <sub>Charge_terminated</sub>		R <sub>PROG</sub> =2kΩ		0.1		V
V <sub>FLOAT</sub>	Float Voltage		4.158	4.2	4.242	V
I <sub>TRIKL</sub>	Trickle Charge Current	R <sub>PROG</sub> =2kΩ		50		mA
V <sub>TRIKL</sub>	Trickle Charge Voltage Threshold	R <sub>PROG</sub> =2kΩ	2.8	2.9	3.0	V
V <sub>TRIKL, HYS</sub>	Trickle Charge Voltage Hysteresis	R <sub>PROG</sub> =2kΩ		100		mV
V <sub>UVLO</sub>	UVLO Threshold	From V <sub>CC</sub> Low to High	3.6	3.8	4.0	V

## Electrical Characteristics (continued)

VCC=5V, TA= 25°C (unless otherwise noted)

Symbol	Parameter	Conditions	Min.	Typ.	Max.	Unit
V <sub>UVLO, HYS</sub>	UVLO Hysteresis			250		mV
V <sub>OVLO</sub>	OVLO Threshold	From V <sub>CC</sub> Low to High		6		V
V <sub>OVLP_HYS</sub>	OVLO Hysteresis			180		mV
V <sub>MSD</sub>	Manual Shutdown Threshold Voltage	PROG Pin Rising PROG Pin Falling		1.2 1.0	1.3	V V
V <sub>ASD</sub>	VCC-VBAT Lockout Threshold Voltage	V <sub>CC</sub> from low to High V <sub>CC</sub> from High to Low	5	120 50		mV mV
ΔV <sub>RECHRG</sub>	Auto Recharge Battery Voltage		100	150	200	mV
V <sub>CHRGb</sub>	CHRGb Pin Output Low Voltage	I <sub>CHRGb</sub> =5mA		0.3	0.6	V
V <sub>DONE</sub>	DONE Pin Output Low Voltage	I <sub>DONE</sub> =5mA		0.3	0.6	V
T <sub>LIM</sub>	Junction Temperature In CT Mode			165		°C
R <sub>ON</sub>	Power FET ON Resistance			250		mΩ
T <sub>SS</sub>	Soft-Start Time	R <sub>PROG</sub> =2kΩ		50		μs
T <sub>RECHRG</sub>	Recharge Comparator Filter Time			2		ms
T <sub>TERM</sub>	Termination Comparator Filter Time			1		ms
I <sub>PROG</sub>	PROG Pin Pull-up Current		0.35	0.5	0.75	μA

Specifications subject to change without notice.

## Typical Performance Characteristics

VCC=5V, TA= 25°C (unless otherwise noted)

**PROG Pin Voltage vs. Ambient Temperature**

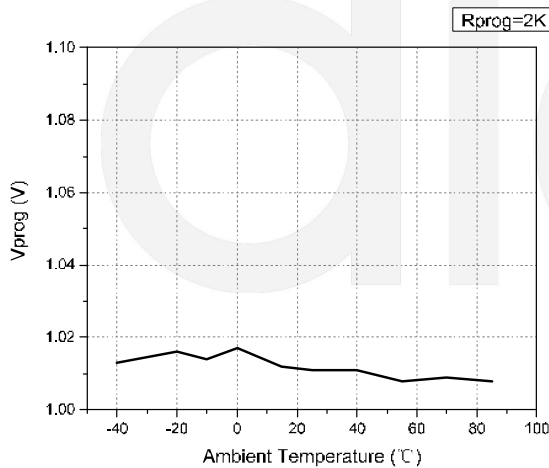

**Float Voltage vs. Ambient Temperature**

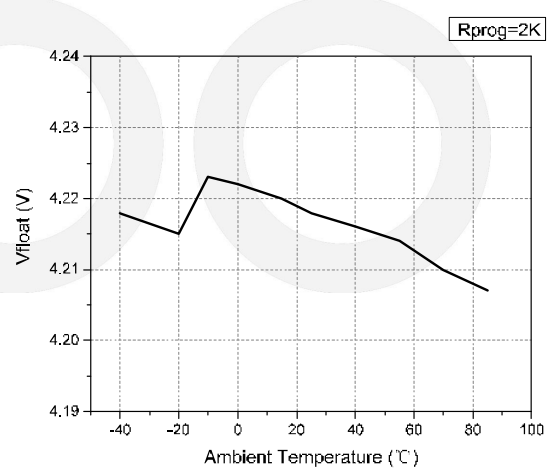

### I<sub>charge</sub> vs. Ambient Temperature

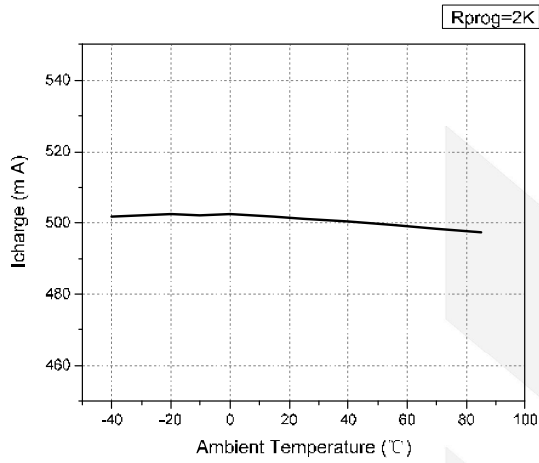

### I<sub>trickle charge</sub> vs. Ambient Temperature

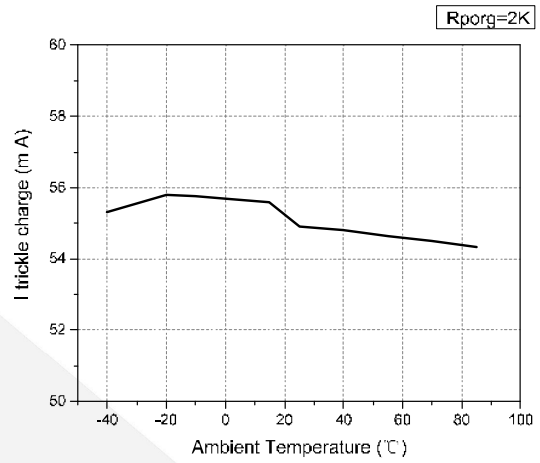

### VCC Start-up

(VCC=5V, R<sub>PROG</sub>=2kΩ, C<sub>BAT</sub>=10μF, BAT connect to battery)

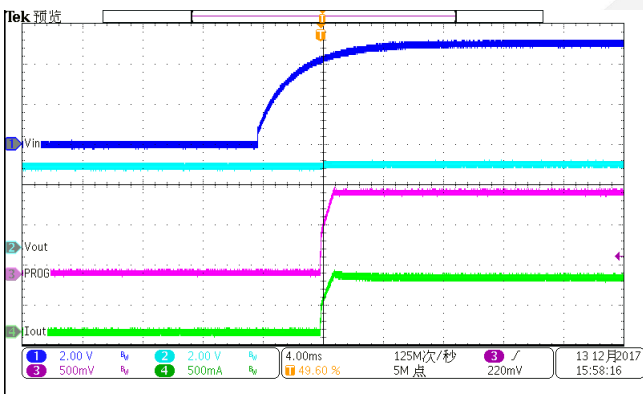

### VCC Shut-down

(VCC=5V, R<sub>PROG</sub>=2kΩ, C<sub>BAT</sub>=10μF, BAT connect to battery)

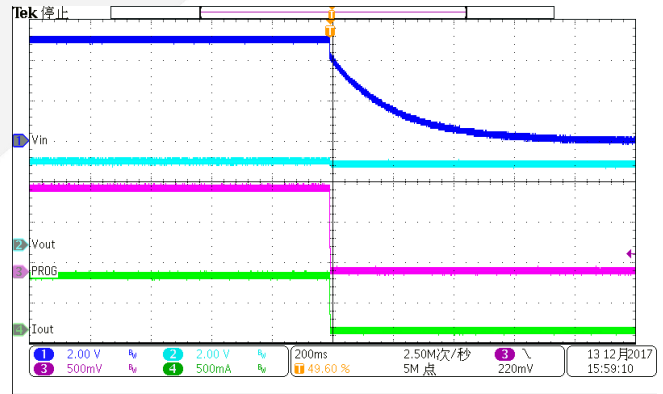

### Charging Curve

(VCC=5V, R<sub>PROG</sub>=10kΩ, C<sub>BAT</sub>=10μF)

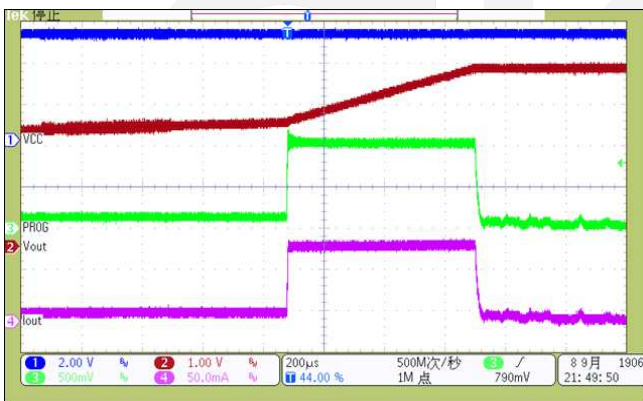

### V<sub>BAT</sub>

(VCC=5V, R<sub>PROG</sub>=10kΩ, C<sub>BAT</sub>=10μF)

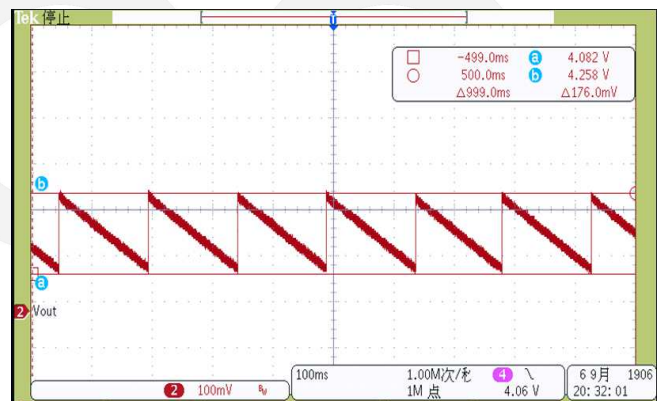



## DIO5508B

### Operation information

The DIO5508B is a single cell Lithium-Ion battery charger using a constant-current / constant-voltage algorithm. It can deliver up to 100mA of charge current with a final float voltage accuracy of  $\pm 1\%$ . The DIO5508B includes an internal P-channel power MOSFET and thermal regulation circuitry. No blocking diode or external current sense resistor is required; thus, the basic charger circuit requires only two external components. Furthermore, the DIO5508B is capable of operating from a USB power source.

#### Normal charge cycle

A charge cycle begins when the voltage at the VCC pin rises above the UVLO threshold level and a 1% program resistor is connected from the PROG pin to ground or when a battery is connected to the charger output. If the BAT pin is less than 2.9V, the charger enters trickle charge mode. In this mode, the DIO5508B supplies approximately 1/10 the programmed charge current to bring the battery voltage up to a safe level for full current charging.

When the BAT pin voltage rises above 2.9V, the charger enters constant-current mode, where the programmed charge current is supplied to the battery. When the BAT pin approaches the final float voltage, the DIO5508B enters constant-voltage mode and the charge current begins to decrease. The charge cycle ends when the PROG voltage is less than 100mV.

#### Programming charge current

The charge current is programmed using a single resistor from the PROG pin to ground. The battery charge current of constant current mode is 1000 times the current out of the PROG pin. The program resistor and the charge current of constant current are calculated using the following equations:

$$I_{CHRG} = \left( \frac{1V}{R_{PROG}} \right) \times 1000$$

#### Charge termination

A charge cycle is terminated when the charge current falls to 1/10 of the programmed value after the final float voltage is reached. This condition is detected by using an internal, filtered comparator to monitor the PROG pin. When the PROG pin voltage falls below 100mV for longer than  $T_{TERM}$  (typically 1ms), charging is terminated. The charge current is latched off and the DIO5508B enters standby mode, where the input supply current drops to 136 $\mu$ A. (Note: CC/10 termination is disabled in trickle charging mode and thermal limiting modes).

When charging, transient loads on the BAT pin can cause the PROG pin to fall below 100mV for short periods of time before the DC charge current has dropped to 1/10 of the programmed value. The 1ms filter time ( $T_{TERM}$ ) on the termination comparator ensures that transient loads of this nature do not result in premature charge cycle termination. Once the average charge current drops below 1/10 of the programmed value, the DIO5508B terminates the charge cycle and ceases to provide any current through the BAT pin, the chip will be put into standby mode. In this state, all loads on the BAT pin must be supplied by the battery.



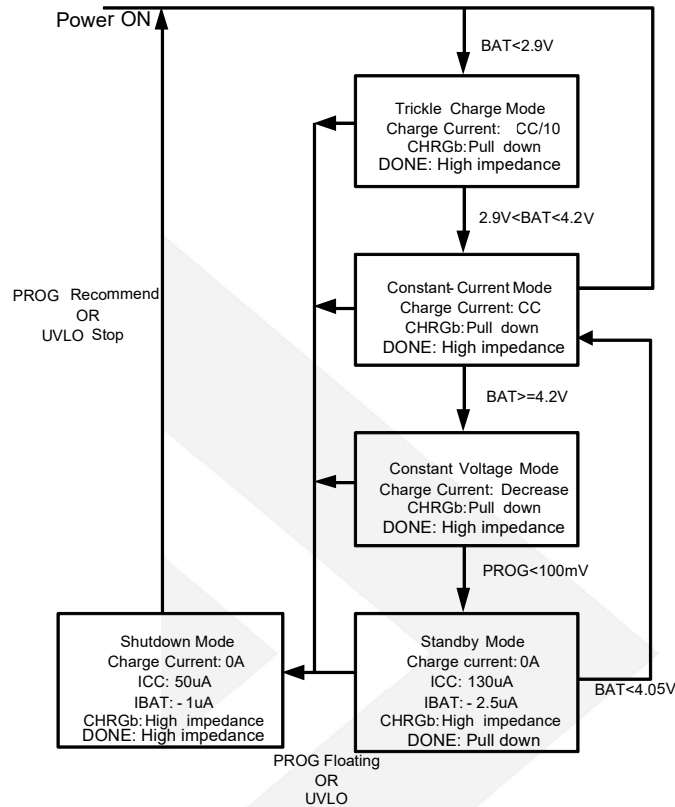

**Figure 4. State Diagram of a Typical Charge Cycle**

The DIO5508B constantly monitors the BAT pin voltage in standby mode. If this voltage drops below the 4.05V recharge threshold ( $V_{RECHRG}$ ), another charge cycle begins and current is once again supplied to the battery. The state diagram of a typical charge cycle is as Figure 4.

### Charge status indicator

DIO5508B has two open-drain status indicator output CHRGb and DONE. CHRGb is pull-down when the DIO5508B in a charge cycle. In other status CHRGb is in high impedance. CHRGb and DONE are all in high impedance.

Represent in failure state, If battery is not connected to charger and the BAT pin connects a 10µF capacitor, the frequency of CHRGb flickers is about 1-4s.

Charger state	Red GHRGb	Green DONE
Charging	light	Dark
Battery in full state	dark	light
BAT pin is connected to 10µF and no battery mode	Red LED flicker and the frequency is 1~4s	

### Thermal Limiting

An internal thermal feedback loop reduces the programmed charge current if the die temperature attempts to rise above a preset value of approximately 165°C. This feature protects the DIO5508B from excessive temperature

and allows the user to push the limits of the power handling capability of a given circuit board without risk of damaging the DIO5508B. The charge current can be set according to typical (not worst-case) ambient temperature with the assurance that the charger will automatically reduce the current in worst-case conditions.

### Undervoltage Lockout (UVLO)

An internal undervoltage lockout circuit monitors the input voltage and keeps the charger in shutdown mode until  $V_{CC}$  rises above the undervoltage lockout threshold. The UVLO circuit has a built-in hysteresis of 250mV. Furthermore, to protect against reverse current in the power MOSFET, the UVLO circuit keeps the charger in shutdown mode if  $V_{CC}$  falls to within 50mV of the battery voltage. If the UVLO comparator is tripped, the charger will not come out of shutdown mode until  $V_{CC}$  rises 120mV above the battery voltage.

### Overvoltage Lockout (OVLO)

An internal overvoltage lockout circuit monitors the input voltage and keeps the charger in shutdown mode until  $V_{CC}$  rises above the overvoltage lockout threshold. The OVLO circuit has a built-in hysteresis of 180mV. Furthermore, to protect against reverse current in the power MOSFET, the OVLO circuit keeps the charger in shutdown mode if  $V_{CC}$  falls to within 50mV of the battery voltage. If the OVLO comparator is tripped, the charger will not come out of shutdown mode until  $V_{CC}$  rises 120mV above the battery voltage.

### Manual Shutdown

At any point in the charge cycle, the DIO5508B can be put into shutdown mode by removing  $R_{PROG}$  thus floating the PROG pin. This reduces the battery drain current to less than  $1\mu A$  and the supply current to less than  $50\mu A$ . A new charge cycle can be initiated by reconnecting the program resistor.

In manual shutdown, The CHRGb pin and the DONE pin are in a high impedance state if the DIO5508B is in manual shutdown mode or in the undervoltage lockout mode: either  $V_{CC}$  is within 120mV of the BAT pin voltage or insufficient voltage is applied to the  $V_{CC}$  pin.

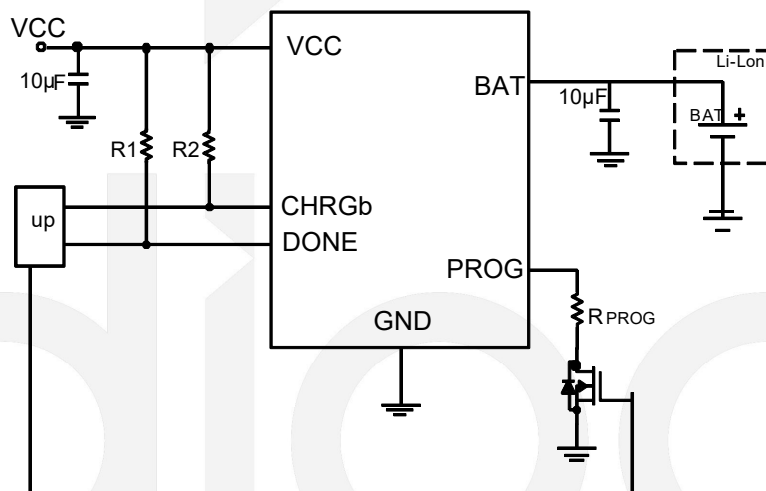

Figure 5. Manual Shutdown Mode Application Circuit

### Automatic recharge

Once the charge cycle is terminated, the DIO5508B continuously monitors the voltage on the BAT pin using a comparator with a 2ms filter time ( $T_{RECHRG}$ ). A charge cycle restarts when the battery voltage falls below 4.05V (Typ.) (which corresponds to approximately 80% to 90% battery capacity). This ensures that the battery is kept at



## DIO5508B

or near a fully charged condition and eliminates the need for periodic charge cycle initiations. CHRGb output enters a pull-down state during recharge cycles.

### Application Information

#### Stability considerations

The constant-voltage mode feedback loop is stable without an output capacitor provided a battery is connected to the charger output. With no battery present, an output capacitor is recommended to reduce ripple voltage. When using high value, low ESR ceramic capacitors, it is recommended to add a 1Ω resistor in series with the capacitor. No series resistor is needed if tantalum capacitors are used.

In constant-current mode, the PROG pin is in the feedback loop, not the battery. The constant-current mode stability is affected by the impedance at the PROG pin. With no additional capacitance on the PROG pin, the charger is stable with program resistor values as high as 50KΩ. However, additional capacitance on this node reduces the maximum allowed program resistor thus it should be avoided.

#### Thermal Limit

An internal thermal feedback loop reduces the programmed charge current if the die temperature attempts to rise above a preset value of approximately 165°C. This feature protects the DIO5508B from excessive temperature and allows the user to push the limits of the power handling capability of a given circuit board without risk of damaging the DIO5508B. The charge current can be set according to typical (not worst-case) ambient temperature with the assurance that the charger will automatically reduce the current in worst-case conditions.

#### Power dissipation

The conditions that cause the DIO5508B to reduce charge current through thermal feed-back can be approximated by considering the power dissipated in the IC. Nearly all of this power dissipation is generated by the internal MOSFET. This is calculated to be approximately:

$$P_D = (V_{CC} - V_{BAT}) \times I_{BAT}$$

It is important to remember that DIO5508B applications do not be designed for worst-case thermal conditions since the IC will automatically reduce power dissipation when the junction temperature reaches approximately 165°C (Constant temperature mode).

#### VCC bypass capacitor

Many types of capacitors can be used for input bypass, however, caution must be exercised when using multilayer ceramic capacitors. Because of the self-resonant and high Q characteristics of some types of ceramic capacitors, a 10μF ceramic capacitor is recommended for this bypass capacitor. Due to a high voltage transient will be generated under some start-up conditions, such as connecting the charger input to a live power source.

#### Charge current soft-start

The DIO5508B includes a soft-start circuit to minimize the inrush current at the start of a charge cycle. When a charge cycle is initiated, the charge current ramps from zero to the full-scale current over a period of approximately 100μs. This has the effect of minimizing the transient current load on the power supply during start-up.



DIO5508B

600mA Lithium Ion Battery Charger IC

## CONTACT US

Dioo is a professional design and sales corporation for high-quality and performance analog semiconductors. The company focuses on industry markets, such as, cell phone, handheld products, laptop, and medical equipment and so on. Dioo's product families include analog signal processing and amplifying, LED drivers and charger IC. Go to <http://www.dioo.com> for a complete list of Dioo product families.

For additional product information, or full datasheet, please contact with our Sales Department or Representatives.

dioo

# Mouser Electronics

Authorized Distributor

Click to View Pricing, Inventory, Delivery & Lifecycle Information:

DIOO:

[DIO5508BST6](#)