

# DIO1642

## Three Port, 4 GHz, High-Speed MIPI Switch

### Features

- Supply voltage: 1.65 V to 5.5 V
- Quiescent current: 17  $\mu$ A
- Low on resistance: 10  $\Omega$
- -3 dB bandwidth: 4 GHz
- Package: QFN3.4\*2.5-24

### Applications

- Dual camera for cell phones
- Dual LCD monitor, digital camera displays

### Descriptions

The DIO1642 is a high-speed analog switch. The pin out is designed to ease differential signal layout and is configured as triple-pole, double-throw switch (TPDPT). The DIO1642 is optimized for switching between two MIPI devices, such as cameras or LCD displays and on-board MAP.

The DIO1642 is compatible with the requirements of MIPI. The low-capacitance design allows the device to switch signals that exceed 4 GHz in frequency. Superior channel-to-channel crosstalk immunity minimizes the interference and allows the transmission of high-speed differential signals and single-ended signals, as described by the MIPI specification.

The DIO1642 is available in QFN3.4\*2.5-24 package. Standard products are Pb-free and halogen-free.

### Typical Application

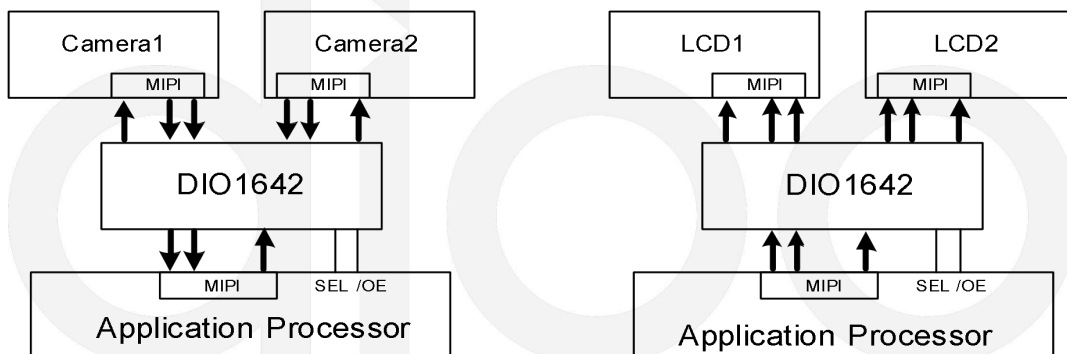

## Ordering Information

Part Number	Top Marking	RoHS	T <sub>A</sub>	Package	
DIO1642EN24	AFD2	Green	-40 to 85°C	QFN3.4*2.5-24	Tape & Reel, 5000

## Pin Assignments

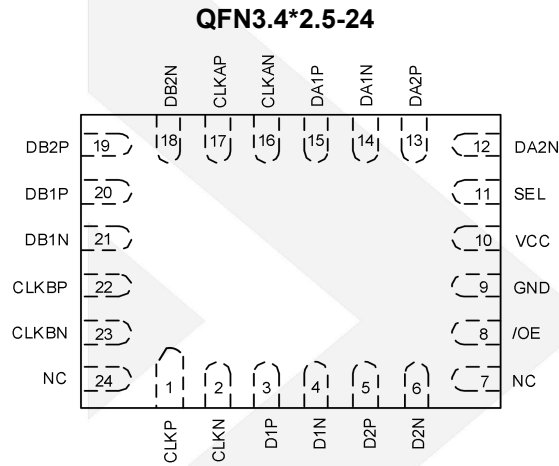

Figure 1. Top View

## Pin Description

Pin Name	Description
CLKP/N	Clock paths (CLKP, CLKN)
D1P/N	Data paths 1 (D1P, D1N)
D2P/N	Data paths 2 (D2P, D2N)
/OE	Output enable (Active Low)
GND	Ground
VCC	Power supply
SEL	Selection (0 = A, 1 = B)
DA2P/N	Data paths (DA2P, DA2N)
DA1P/N	Data paths (DA1P, DA2N)
CLKAP/N	Clock paths (CLKAP, CLKAN)
DB2P/N	Data paths (DB2P, DB2N)
DB1P/N	Data paths (DB1P, DB2N)
CLKBP/N	Clock paths (CLKBP, CLKBN)
NC	No connection

## Truth Table

SEL	/OE	Function
X	H	Bus switch disconnected
L	L	D1,D2,CLK = DA1,DA2,CLKA
H	L	D1,D2,CLK = DB1,DB2,CLKB

## Function Diagram

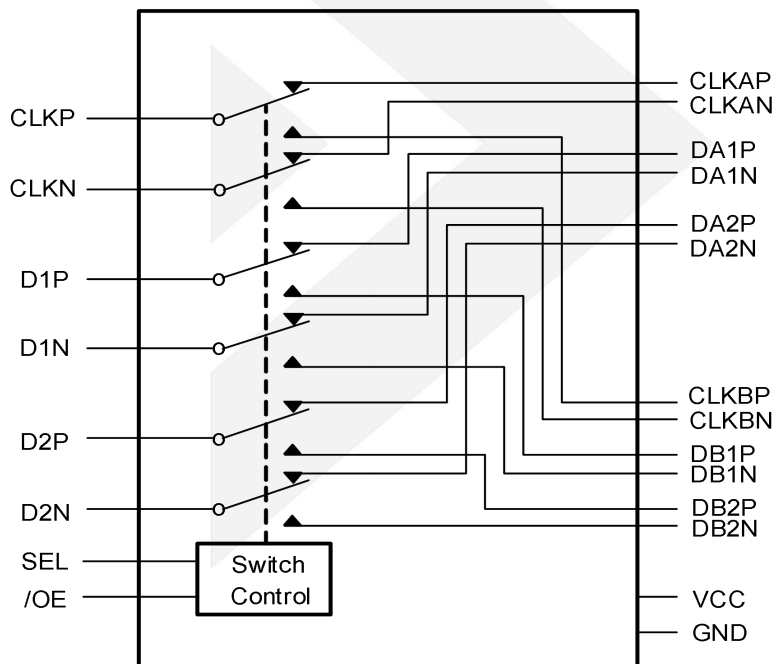



# DIO1642

Three Port, 4 GHz, High-Speed MIPI Switch

## Absolute Maximum Ratings

Stresses beyond those listed under the Absolute Maximum Rating table may cause permanent damage to the device. These are stress ratings only and functional operation of the device at these or any other condition beyond those indicated in the operational sections of the specifications is not implied. Exposure to absolute maximum rating conditions for extended periods may affect device reliability.

Symbol	Parameter	Rating	Unit
VCC	Supply voltage range	-0.5 to 6.5	V
V <sub>DATA</sub>	Data input/output voltage range	-0.5 to 6.5	V
V <sub>SEL</sub>	Select input voltage range	-0.5 to 6.5	V
I <sub>OUT</sub>	Continues output current	±50	mA
T <sub>J</sub>	Junction temperature range	150	°C
T <sub>L</sub>	Lead temperature range	260	°C
T <sub>STG</sub>	Storage temperature range	-65 to 150	°C
R <sub>θJA</sub>	Thermal resistance	250	°C/W
ESD Human Body Model (HBM)	I/O to VCC, I/O to GND	±5000	V

## Recommended Operating Conditions

The Recommended Operating Conditions table defines the conditions for actual device operation. Recommended operating conditions are specified to ensure optimal performance to the datasheet specifications. DIOO does not recommend exceeding them or designing to absolute maximum ratings.

Symbol	Parameter	Rating	Unit
VCC	Supply voltage range	1.65 to 5.5	V
V <sub>DATA</sub>	Data input/output voltage range	0 to VCC	V
V <sub>SEL</sub>	Select input voltage range	0 to VCC	V
V <sub>IOE</sub>	Enable control input voltage range	0 to VCC	V
T <sub>A</sub>	Operating temperature range	-40 to 85	°C



# DIO1642

Three Port, 4 GHz, High-Speed MIPI Switch

## Electrical Characteristics

T<sub>A</sub> = 25°C, V<sub>CC</sub> = 2.5 V, unless otherwise noted.

Symbol	Parameter	Conditions	Min	Typ	Max	Unit
V <sub>IH</sub>	Select and /OE logic high level	V <sub>CC</sub> = 3.6 to 4.5 V	1.5			V
		V <sub>CC</sub> = 2.3 to 3.6 V	1.3			V
V <sub>IL</sub>	Select and /OE logic low level	V <sub>CC</sub> = 3.6 to 4.5 V			0.6	V
		V <sub>CC</sub> = 2.3 to 3.6 V			0.4	V
I <sub>CC</sub>	Supply quiescent current	I <sub>OUT</sub> = 0, V <sub>SEL</sub> > 1.5 V or V <sub>SEL</sub> < 0.7 V		17	35	uA
I <sub>SEL</sub>	Select input leakage current	V <sub>SEL</sub> = V <sub>CC</sub>			±1.0	uA
I <sub>OFF</sub>	Off state switch leakage current				±1.0	uA
R <sub>ON</sub>	On-resistance	V <sub>CC</sub> = 3.0 V, V <sub>DATA</sub> = 0 to 0.4 V, I <sub>OUT</sub> = 8 mA		10	13	Ω
Δ R <sub>ON</sub>	On-resistance match	V <sub>CC</sub> = 3.0 V, V <sub>DATA</sub> = 0 to 0.4 V, I <sub>OUT</sub> = 8 mA		0.1		Ω
R <sub>FLAT(ON)</sub>	On-resistance flatness	V <sub>CC</sub> = 3.0 V, V <sub>DATA</sub> = 0 to 1.0 V, I <sub>OUT</sub> = 8 mA		1		Ω
T <sub>PD</sub>	Propagation delay time	C <sub>L</sub> = 5 pF, R <sub>L</sub> = 50 Ω		0.2		ns
T <sub>ON</sub>	Select input to switch on time	C <sub>L</sub> = 10 pF, R <sub>L</sub> = 50 Ω		90	120	ns
T <sub>OFF</sub>	Select input to switch off time	C <sub>L</sub> = 10 pF, R <sub>L</sub> = 50 Ω		40	80	ns
T <sub>BBM</sub>	Break-Before-Make time	Generated by design		50		ns
BW	-3dB Bandwidth	R <sub>L</sub> = 50 Ω, C <sub>L</sub> = 0 pF	3	4		GHz
OIRR	Off isolation	R <sub>L</sub> = 50 Ω, f = 100 MHz		-40		dB
Xtalk	Crosstalk	R <sub>L</sub> = 50 Ω, f = 100 MHz		-44		dB
C <sub>IN</sub>	Select pin input capacitance	V <sub>CC</sub> = 0 V		6		pF
C <sub>OFF</sub>	D1n, D2n, Dn Off capacitance	V <sub>CC</sub> = 3.3 V, /OE = 3.3 V		5		pF
C <sub>ON</sub>	D1n, D2n, Dn On capacitance	V <sub>CC</sub> = 3.3 V, /OE = 0 V		4		pF

### Application Information

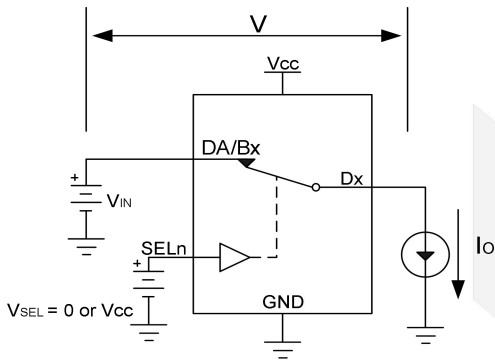

$$R_{ON} = V / I_o$$

Figure 2. ON resistance

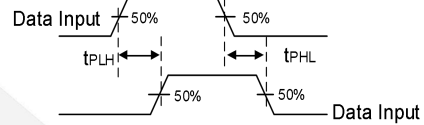
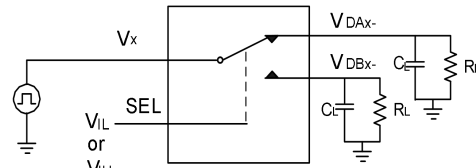

Figure 3. Propagation delay time

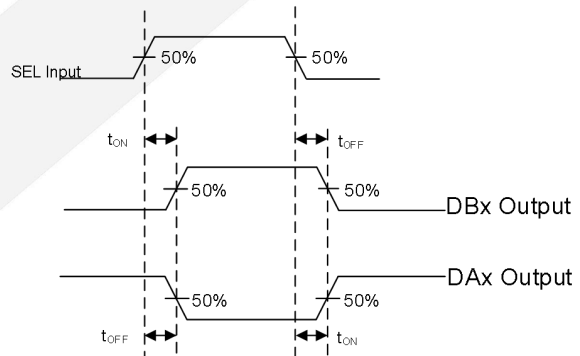
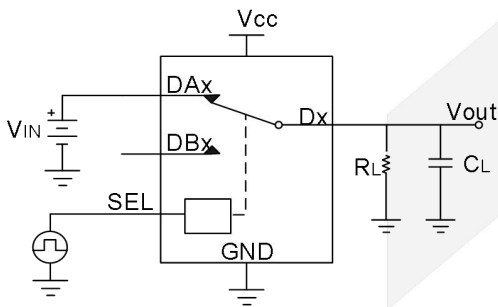
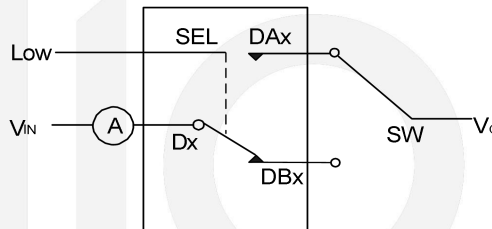

Figure 4. Select input to switch on/off time



Conditions  $V_{IN} = 4.5\text{ V}$   $V_o = \text{GND}$

Figure 5. Off state switch leakage current

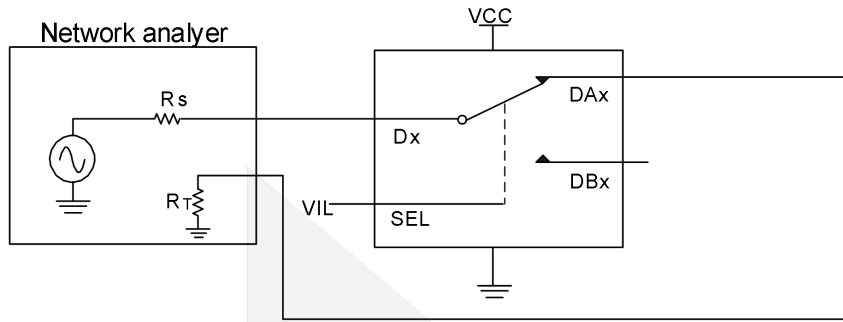

Figure 6. Bandwidth (BW)

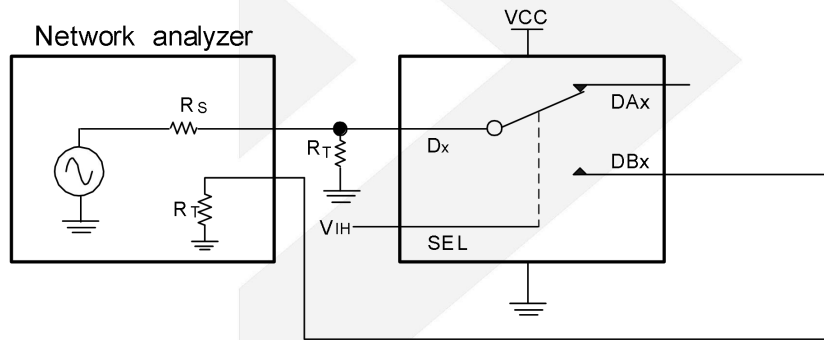

Figure 7. Off isolation (OIRR)

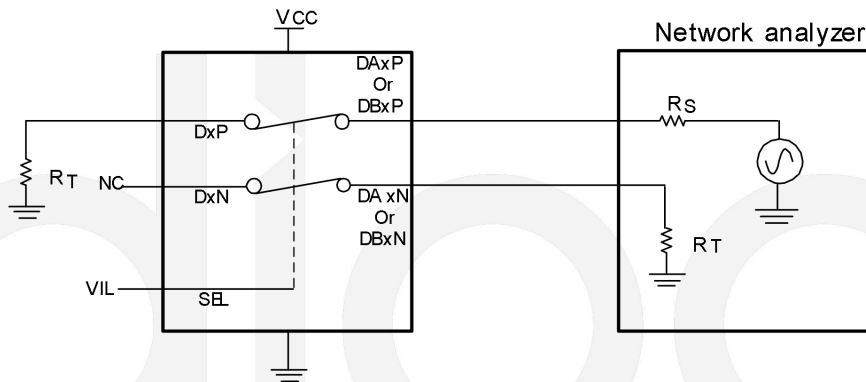

Figure 8. Crosstalk (Xtalk)

## Typical Performance Characteristics

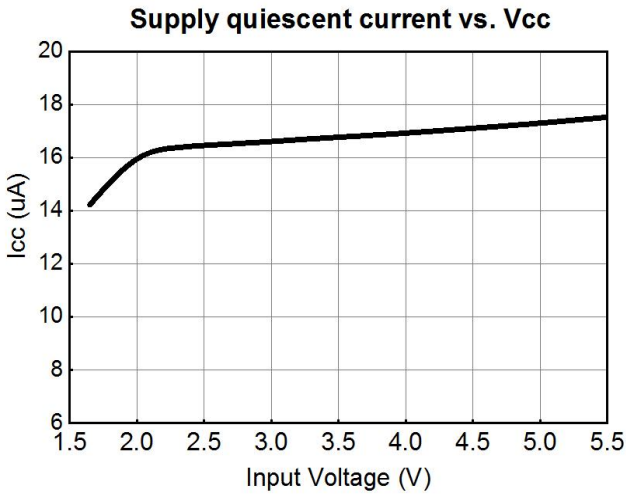

Figure 9. Supply quiescent current Vs. Vcc

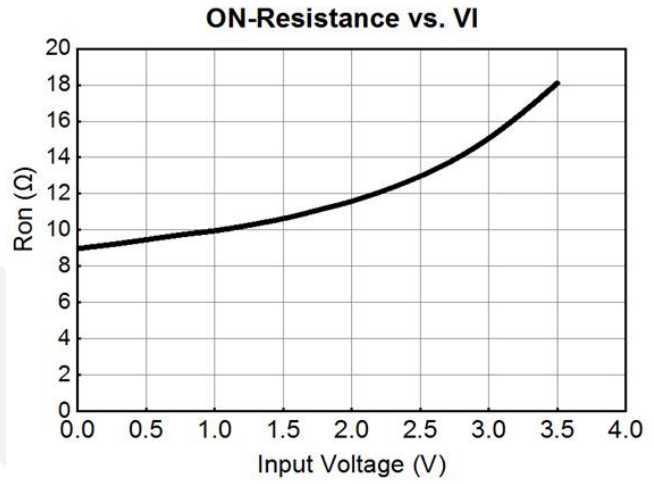

Figure 10. R<sub>ON</sub> Vs. V<sub>I</sub>

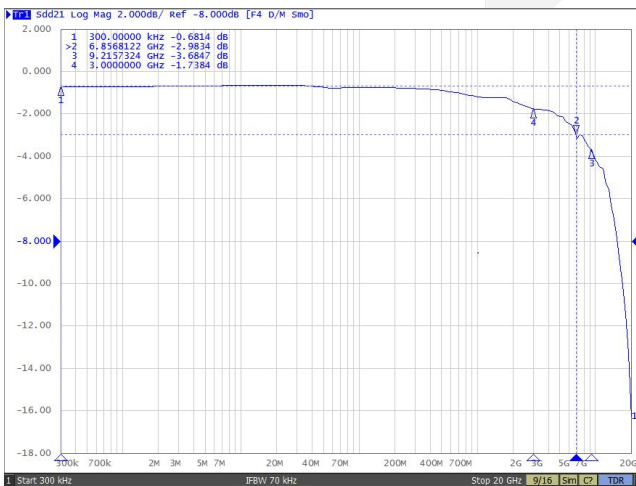

Figure 11. Bandwidth Vs. Frequency

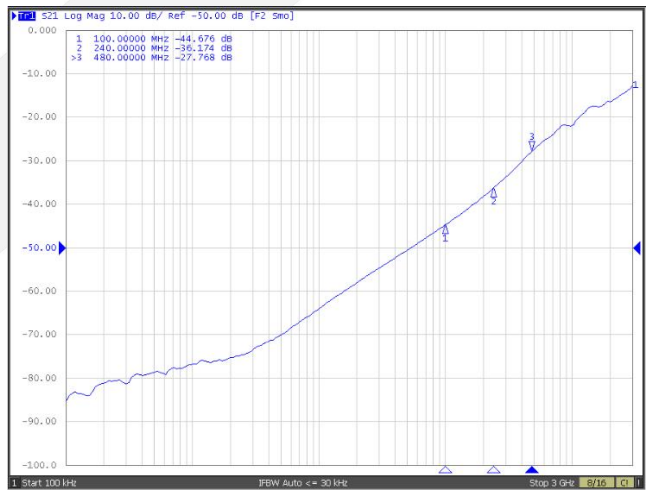

Figure 12. Crosstalk Vs. Frequency

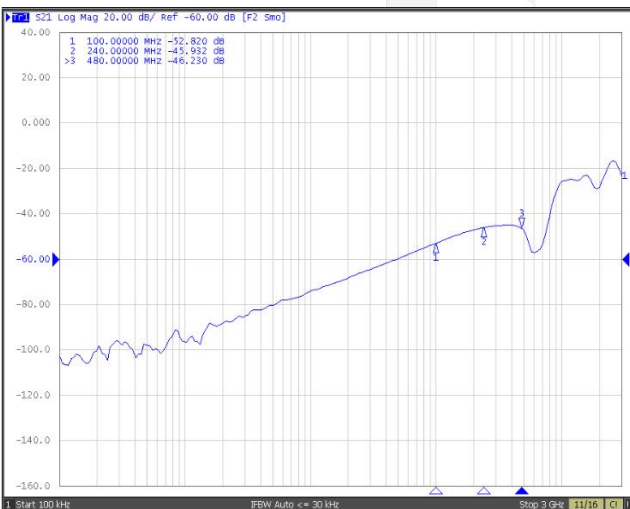
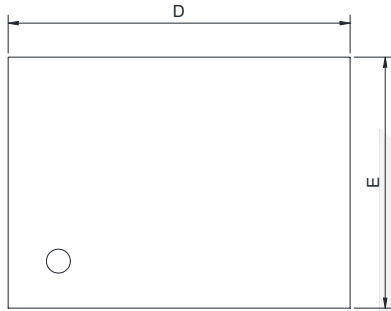

Figure 13. Off isolation Vs. Frequency



## Physical Dimensions: QFN3.4\*2.5-24



TOP VIEW

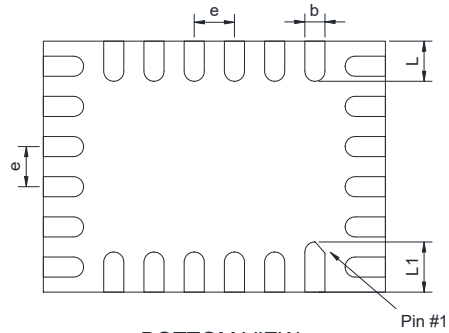

BOTTOM VIEW

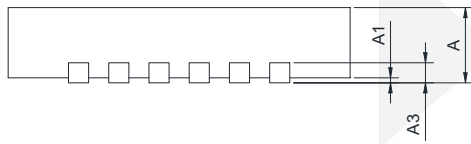

SIDE VIEW

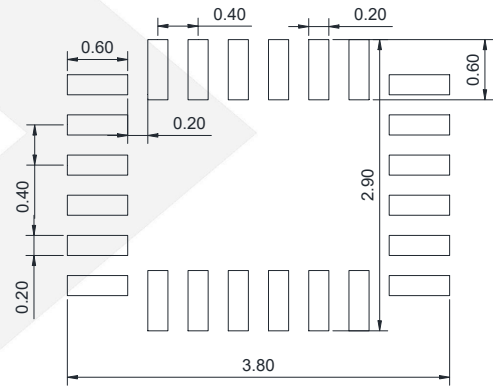

RECOMMENDED LAND PATTERN(Unit:mm)

Common Dimensions(mm)			
Symbol	Min	Nom	Max
A	0.70	0.75	0.80
A1	0.00	0.02	0.05
A3	0.2 REF		
D	3.30	3.40	3.50
E	2.40	2.50	2.60
b	0.15	0.20	0.25
e	0.4 BSC		
L	0.30	0.40	0.50
L1	0.40	0.50	0.60



DIO1642

Three Port, 4 GHz, High-Speed MIPI Switch

## CONTACT US

Dioo is a professional design and sales corporation for high-quality and performance analog semiconductors. The company focuses on industry markets, such as cell phones, handheld products, laptops, medical equipment, and so on. Dioo's product families include analog signal processing and amplifying, LED drivers, and charger ICs. Go to <http://www.dioo.com> for a complete list of Dioo product families.

For additional product information or full datasheet, please contact our sales department or representatives.

dioo

# Mouser Electronics

Authorized Distributor

Click to View Pricing, Inventory, Delivery & Lifecycle Information:

[DIOO:](#)

[DIO1642EN24](#)