

96 kHz Digital Audio Interface Receiver

Features

- ◆ Complete EIAJ CP1201, IEC-60958, AES3, S/PDIF-compatible Receiver
- ◆ +5.0 V Analog Supply (VA+)
- ◆ +3.3 V or +5.0 V Digital Interface (VL+)
- ◆ 7:1 S/PDIF Input MUX
- ◆ Flexible 3-wire Serial Digital Output Port
- ◆ 8-kHz to 96-kHz Sample Frequency Range
- ◆ Low-jitter Clock Recovery
- ◆ Pin and Microcontroller Read Access to Channel Status and User Data
- ◆ Microcontroller and Standalone Modes
- ◆ Differential Cable Receiver
- ◆ On-chip Channel Status and User Data Buffer Memories
- ◆ Auto-detection of Compressed Audio Input Streams
- ◆ Decodes CD Q Sub-Code
- ◆ OMCK System Clock Mode

General Description

The CS8415A is a monolithic CMOS device which receives and decodes one of 7 channels of audio data according to the IEC60958, S/PDIF, EIAJ CP1201, or AES3. The CS8415A has a serial digital audio output port and comprehensive control ability through a 4-wire microcontroller port. Channel status and user data are assembled in block-sized buffers, making read access easy.

A low-jitter clock recovery mechanism yields a very clean recovered clock from the incoming AES3 stream.

Stand-alone operation allows systems with no microcontroller to operate the CS8415A with dedicated output pins for channel status data.

The CS8415A is available in a 28-pin TSSOP and SOIC package in both Commercial (-10 to +70°C) and Industrial grades (-40 to +85° C). The CDB8415A Customer Demonstration board is also available for device evaluation and implementation suggestions. Please refer to [page 2](#) for ordering information.

Target applications include A/V receivers, CD-R, DVD receivers, multimedia speakers, digital mixing consoles, effects processors, set-top boxes, and computer and automotive audio systems.

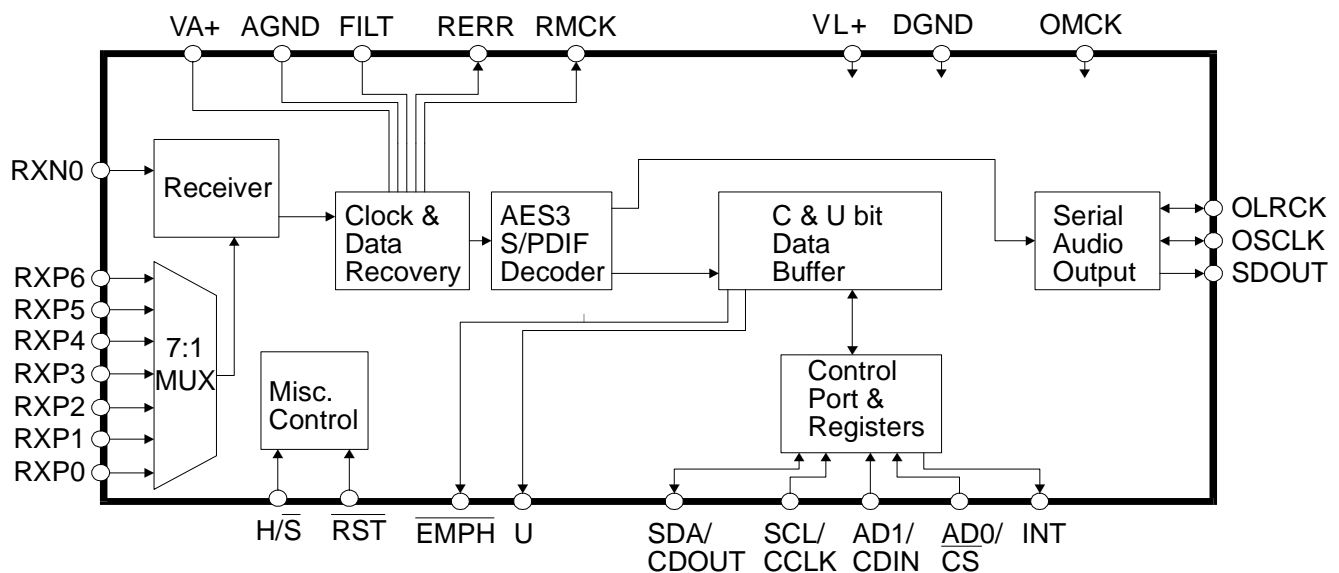

ORDERING INFORMATION

Product	Description	Package	Grade	Temp Range	Pb-Free	Container	Order Number	
CS8415A	96 kHz Digital Audio Interface Receiver	28-TSSOP	Commercial	-10 to +70°C	YES	Rail	CS8415A-CZZ	
						Tape and Reel	CS8415A-CZZR	
			Industrial	-40 to +85°C	NO	Rail	CS8415A-CZ	
						Tape and Reel	CS8415A-CZR	
		28-SOIC	Commercial	-10 to +70°C	YES	Rail	CS8415A-IZZ	
						Tape and Reel	CS8415A-IZZR	
						YES	Rail	CS8415A-CSZ
							Tape and Reel	CS8415A-CSZR
			NO	Rail	CS8415A-CS			
					Tape and Reel	CS8415A-CSR		
CDB8415A	CS8415A Evaluation Board		-	-	-	-	CDB8415A	

TABLE OF CONTENTS

1. CHARACTERISTICS AND SPECIFICATIONS	6
SPECIFIED OPERATING CONDITIONS	6
ABSOLUTE MAXIMUM RATINGS	6
DC ELECTRICAL CHARACTERISTICS	6
DIGITAL INPUT CHARACTERISTICS	7
DIGITAL INTERFACE SPECIFICATIONS	7
SWITCHING CHARACTERISTICS	7
SWITCHING CHARACTERISTICS - SERIAL AUDIO PORTS	8
SWITCHING CHARACTERISTICS - CONTROL PORT - SPI MODE	9
SWITCHING CHARACTERISTICS - CONTROL PORT - I ² C MODE	10
2. TYPICAL CONNECTION DIAGRAM	11
3. GENERAL DESCRIPTION	12
3.1 AES3 and S/PDIF Standards Documents	12
4. SERIAL AUDIO OUTPUT PORT	13
5. AES3 RECEIVER	15
5.1 7:1 S/PDIF Input Multiplexer	15
5.2 OMCK System Clock Mode	15
5.3 PLL, Jitter Attenuation, and Varispeed	15
5.4 Error Reporting and Hold Function	15
5.5 Channel Status Data Handling	16
5.6 User Data Handling	16
5.7 Non-Audio Auto-Detection	16
5.8 Mono Mode Operation	17
6. CONTROL PORT DESCRIPTION AND TIMING	18
6.1 SPITM Mode	18
6.2 I ² C Mode	19
6.3 Interrupts	19
7. CONTROL PORT REGISTER SUMMARY	20
7.1 Memory Address Pointer (MAP)	20
8. CONTROL PORT REGISTER BIT DEFINITIONS	21
8.1 Control 1 (01h)	21
8.2 Control 2 (02h)	21
8.3 Clock Source Control (04h)	22
8.4 Serial Audio Output Port Data Format (06h)	22
8.5 Interrupt 1 Status (07h) (Read Only)	23
8.6 Interrupt 2 Status (08h) (Read Only)	24
8.7 Interrupt 1 Mask (09h)	24
8.8 Interrupt 1 Mode MSB (0Ah) and Interrupt 1 Mode LSB (0Bh)	24
8.9 Interrupt 2 Mask (0Ch)	24
8.10 Interrupt 2 Mode MSB (0Dh) and Interrupt 2 Mode LSB (0Eh)	25
8.11 Receiver Channel Status (0Fh) (Read Only)	25
8.12 Receiver Error (10h) (Read Only)	26
8.13 Receiver Error Mask (11h)	26
8.14 Channel Status Data Buffer Control (12h)	27
8.15 User Data Buffer Control (13h)	27
8.16 Q-Channel Subcode Bytes 0 to 9 (14h - 1Dh) (Read Only)	28
8.17 OMCK/RMCK Ratio (1Eh) (Read Only)	28
8.18 C-bit or U-bit Data Buffer (20h - 37h)	28
8.19 CS8415A I.D. and Version Register (7Fh) (Read Only)	28
9. PIN DESCRIPTION - SOFTWARE MODE	29
10. HARDWARE MODE	31
10.1 Serial Audio Port Formats	31
11. PIN DESCRIPTION - HARDWARE MODE	32
12. APPLICATIONS	34
12.1 Reset, Power Down and Start-Up	34
12.2 ID Code and Revision Code	34
12.3 Power Supply, Grounding, and PCB Layout	34

13. APPENDIX A: EXTERNAL AES3/SPDIF/IEC60958 RECEIVER COMPONENTS	35
13.1 AES3 Receiver External Components	35
13.2 Isolating Transformer Requirements	36
14. APPENDIX B: CHANNEL STATUS AND USER DATA BUFFER MANAGEMENT	37
14.1 AES3 Channel Status (C) Bit Management	37
14.2 Accessing the E Buffer	37
14.2.1 Reserving the First 5 Bytes in the E Buffer	38
14.2.2 Serial Copy Management System (SCMS)	38
14.2.3 Channel Status Data E Buffer Access	38
14.2.3.1 One-Byte Mode	38
14.2.3.2 Two-Byte Mode	39
14.3 AES3 User (U) Bit Management	39
15. APPENDIX C: PLL FILTER	40
15.1 General	40
15.2 External Filter Components	41
15.2.1 General	41
15.2.2 Capacitor Selection	41
15.2.3 Circuit Board Layout	41
15.3 Component Value Selection	42
15.3.1 Identifying the Part Revision	42
15.3.2 External Components	42
15.3.3 Jitter Tolerance	43
15.3.4 Jitter Attenuation	44
16. REVISION HISTORY	45

LIST OF FIGURES

Figure 1. Audio Port Master Mode Timing	8
Figure 2. Audio Port Slave Mode and Data Input Timing.....	8
Figure 3. SPI Mode Timing	9
Figure 4. I ² C Mode Timing	10
Figure 5. Recommended Connection Diagram for Software Mode	11
Figure 6. Serial Audio Output Example Formats.....	14
Figure 7. AES3 Receiver Timing for C & U Pin Output Data	17
Figure 8. Control Port Timing in SPI Mode	18
Figure 9. Control Port Timing in I ² C Mode	19
Figure 10. Hardware Mode	31
Figure 11. Professional Input Circuit.....	36
Figure 12. Transformerless Professional Input Circuit.....	36
Figure 13. Consumer Input Circuit	36
Figure 14. S/PDIF MUX Input Circuit	36
Figure 15. TTL/CMOS Input Circuit.....	36
Figure 16. Channel Status Data Buffer Structure.....	37
Figure 17. Flowchart for Reading the E Buffer.....	38
Figure 18. PLL Block Diagram	40
Figure 19. Recommended Layout Example.....	41
Figure 20. Jitter Tolerance Template	43
Figure 21. Revision A.....	44
Figure 22. Revision A1	44
Figure 23. Revision A2 using A1 Values.....	44
Figure 24. Revision A2 using A2* Values	44

LIST OF TABLES

Table 1. Control Register Map Summary.....	20
Table 2. Equivalent Software Mode Bit Definitions	31
Table 3. Hardware Mode Start-Up Options.....	31
Table 4. Second Line Part Marking.....	42
Table 5. Fs = 8 to 96 kHz.....	42
Table 6. Fs = 32 to 96 kHz.....	42
Table 7. Revision History	45

1. CHARACTERISTICS AND SPECIFICATIONS

All Min/Max characteristics and specifications are guaranteed over the Specified Operating Conditions. Typical performance characteristics and specifications are derived from measurements taken at nominal supply voltages and $T_A = 25^\circ\text{C}$.

SPECIFIED OPERATING CONDITIONS

AGND, DGND = 0 V, all voltages with respect to 0 V.

Parameter	Symbol	Min	Typ	Max	Units	
Power Supply Voltage	VA+	4.5	5.0	5.5	V	
	VL+ (Note 1)	2.85	3.3 or 5.0	5.5	V	
Ambient Operating Temperature:	Commercial Grade Industrial Grade	T_A	-10	-	+70	$^\circ\text{C}$
			-40	-	+85	

Notes:

- $I^2\text{C}$ protocol is supported only in VL+ = 5.0 V mode.

ABSOLUTE MAXIMUM RATINGS

AGND, DGND = 0 V; all voltages with respect to 0 V. Operation beyond these limits may result in permanent damage to the device. Normal operation is not guaranteed at these extremes.

Parameter	Symbol	Min	Max	Units
Power Supply Voltage	VL+, VA+	-	6.0	V
Input Current, Any Pin Except Supplies (Note 2)	I_{in}	-	± 10	mA
Input Voltage	V_{in}	-0.3	(VL+) + 0.3	V
Ambient Operating Temperature (power applied)	T_A	-55	125	$^\circ\text{C}$
Storage Temperature	T_{stg}	-65	150	$^\circ\text{C}$

- Transient currents of up to 100 mA will not cause SCR latch-up.

DC ELECTRICAL CHARACTERISTICS

AGND = DGND = 0 V; all voltages with respect to 0 V.

Parameters	Symbol	Min	Typ	Max	Units
Power-down Mode (Note 3)					
Supply Current in power down	VA+	-	20	-	μA
	VL+ = 3.3 V	-	60	-	μA
	VL+ = 5.0 V	-	60	-	μA
Normal Operation (Note 4)					
Supply Current at 48 kHz frame rate	VA+	-	6.3	-	mA
	VL+ = 3.3 V	-	30.1	-	mA
	VL+ = 5.0 V	-	46.5	-	mA
Supply Current at 96 kHz frame rate	VA+	-	6.6	-	mA
	VL+ = 3.3 V	-	44.8	-	mA
	VL+ = 5.0 V	-	76.6	-	mA

- Power Down Mode is defined as $\overline{\text{RST}} = \text{LO}$ with all clocks and data lines held static.
- Normal operation is defined as $\overline{\text{RST}} = \text{HI}$.

DIGITAL INPUT CHARACTERISTICS

Parameters	Symbol	Min	Typ	Max	Units
Input Leakage Current	I_{in}	-	± 1	± 10	μA
Differential Input Voltage, RXP0 to RXN0	V_{TH}	-	200	-	mV

DIGITAL INTERFACE SPECIFICATIONS

AGND = DGND = 0 V; all voltages with respect to 0 V.

Parameters	Symbol	Min	Max	Units
High-Level Output Voltage ($I_{OH} = -3.2$ mA)	V_{OH}	(VL+) - 1.0	-	V
Low-Level Output Voltage ($I_{OH} = 3.2$ mA)	V_{OL}	-	0.4	V
High-Level Input Voltage, except RX_n	V_{IH}	2.0	(VL+) + 0.3	V
Low-Level Input Voltage, except RX_n (Note 5)	V_{IL}	-0.3	0.4/0.8	V

5. At 5.0 V mode, $V_{IL} = 0.8$ V (Max), at 3.3 V mode, $V_{IL} = 0.4$ V (Max).

SWITCHING CHARACTERISTICS

Inputs: Logic 0 = 0 V, Logic 1 = VL+; $C_L = 20$ pF.

Parameter	Symbol	Min	Typ	Max	Units
\overline{RST} pin Low Pulse Width		200	-	-	μs
PLL Clock Recovery Sample Rate Range		8.0	-	108.0	kHz
RMCK output jitter (Note 6)		-	200	-	ps RMS
RMCK output duty cycle		40	50	60	%

6. Cycle-to-cycle using 32 to 96 kHz external PLL filter components.

SWITCHING CHARACTERISTICS - SERIAL AUDIO PORTS

Inputs: Logic 0 = 0 V, Logic 1 = VL+; C_L = 20 pF.

Parameter	Symbol	Min	Typ	Max	Units
OSCLK Active Edge to SDOUT Output Valid (Note 7)	t _{dpd}	-	-	20	ns
Master Mode					
RMCK to OSCLK active edge delay (Note 7)	t _{smd}	0	-	10	ns
RMCK to OLRCK delay (Note 8)	t _{lmd}	0	-	10	ns
OSCLK and OLRCK Duty Cycle		-	50	-	%
Slave Mode					
OSCLK Period (Note 9)	t _{sckw}	36	-	-	ns
OSCLK Input Low Width	t _{sckl}	14	-	-	ns
OSCLK Input High Width	t _{sckh}	14	-	-	ns
OSCLK Active Edge to OLRCK Edge (Note 7, 8, 10)	t _{lrckd}	20	-	-	ns
OLRCK Edge Setup Before OSCLK Active Edge (Notes 7, 8, 11)	t _{lrcks}	20	-	-	ns

7. The active edges of OSCLK are programmable.
8. The polarity OLRCK is programmable.
9. No more than 128 SCLK per frame.
10. This delay is to prevent the previous OSCLK edge from being interpreted as the first one after OLRCK has changed.
11. This setup time ensures that this OSCLK edge is interpreted as the first one after OLRCK has changed.

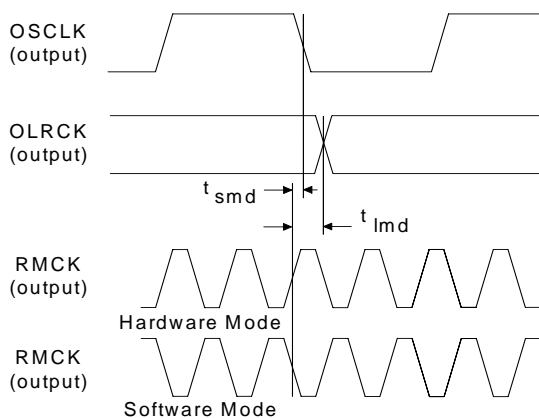

Figure 1. Audio Port Master Mode Timing

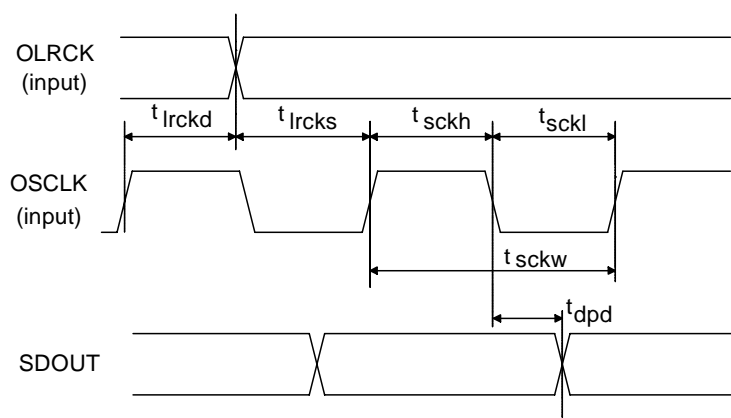

Figure 2. Audio Port Slave Mode and Data Input Timing

SWITCHING CHARACTERISTICS - CONTROL PORT - SPI MODE

Inputs: Logic 0 = 0 V, Logic 1 = VL+; C_L = 20 pF.

Parameter	Symbol	Min	Typ	Max	Units
CCLK Clock Frequency (Note 12)	f _{sck}	0	-	6.0	MHz
$\overline{\text{CS}}$ High Time Between Transmissions	t _{csh}	1.0	-	-	μs
$\overline{\text{CS}}$ Falling to CCLK Edge	t _{css}	20	-	-	ns
CCLK Low Time	t _{scl}	66	-	-	ns
CCLK High Time	t _{sch}	66	-	-	ns
CDIN to CCLK Rising Setup Time	t _{dsu}	40	-	-	ns
CCLK Rising to DATA Hold Time (Note 13)	t _{dh}	15	-	-	ns
CCLK Falling to CDOUT Stable	t _{pd}	-	-	50	ns
Rise Time of CDOUT	t _{r1}	-	-	25	ns
Fall Time of CDOUT	t _{f1}	-	-	25	ns
Rise Time of CCLK and CDIN (Note 14)	t _{r2}	-	-	100	ns
Fall Time of CCLK and CDIN (Note 14)	t _{f2}	-	-	100	ns

12. If F_s is lower than 46.875 kHz, the maximum CCLK frequency should be less than 128 F_s. This is dictated by the timing requirements necessary to access the Channel Status and User Bit buffer memory. Access to the control register file can be carried out at the full 6 MHz rate. The minimum allowable input sample rate is 8 kHz, so choosing CCLK to be less than or equal to 1.024 MHz should be safe for all possible conditions.

13. Data must be held for sufficient time to bridge the transition time of CCLK.

14. For f_{sck} < 1 MHz.

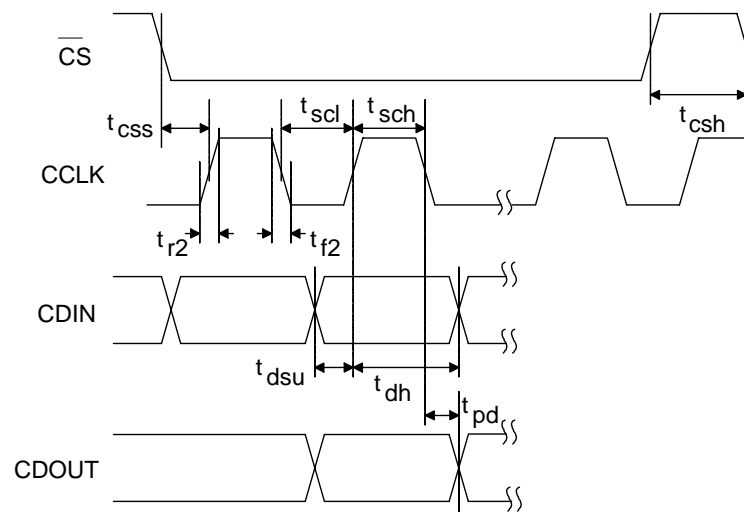

Figure 3. SPI Mode Timing

SWITCHING CHARACTERISTICS - CONTROL PORT - I²C MODE

(Note 15), Inputs: Logic 0 = 0 V, Logic 1 = VL+; C_L = 20 pF.

Parameter	Symbol	Min	Typ	Max	Units
SCL Clock Frequency	f _{scl}	-	-	100	kHz
Bus Free Time Between Transmissions	t _{buf}	4.7	-	-	μs
Start Condition Hold Time (prior to first clock pulse)	t _{hdst}	4.0	-	-	μs
Clock Low Time	t _{low}	4.7	-	-	μs
Clock High Time	t _{high}	4.0	-	-	μs
Setup Time for Repeated Start Condition	t _{sust}	4.7	-	-	μs
SDA Hold Time from SCL Falling (Note 16)	t _{hdd}	0	-	-	μs
SDA Setup Time to SCL Rising	t _{sud}	250	-	-	ns
Rise Time of Both SDA and SCL Lines	t _r	-	-	25	ns
Fall Time of Both SDA and SCL Lines	t _f	-	-	25	ns
Setup Time for Stop Condition	t _{susp}	4.7	-	-	μs

15. I²C protocol is supported only in VL+ = 5.0 V mode.

16. Data must be held for sufficient time to bridge the 25 ns transition time of SCL.

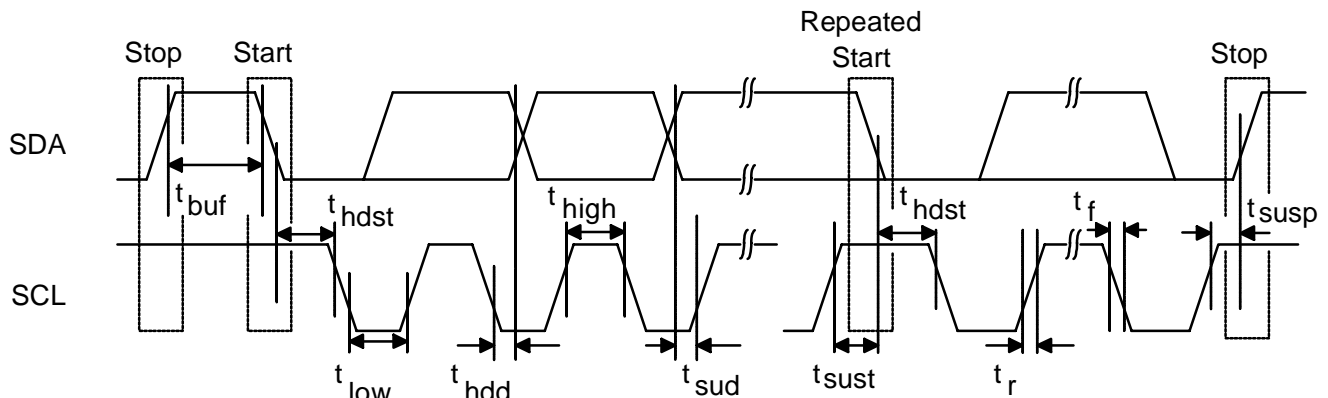
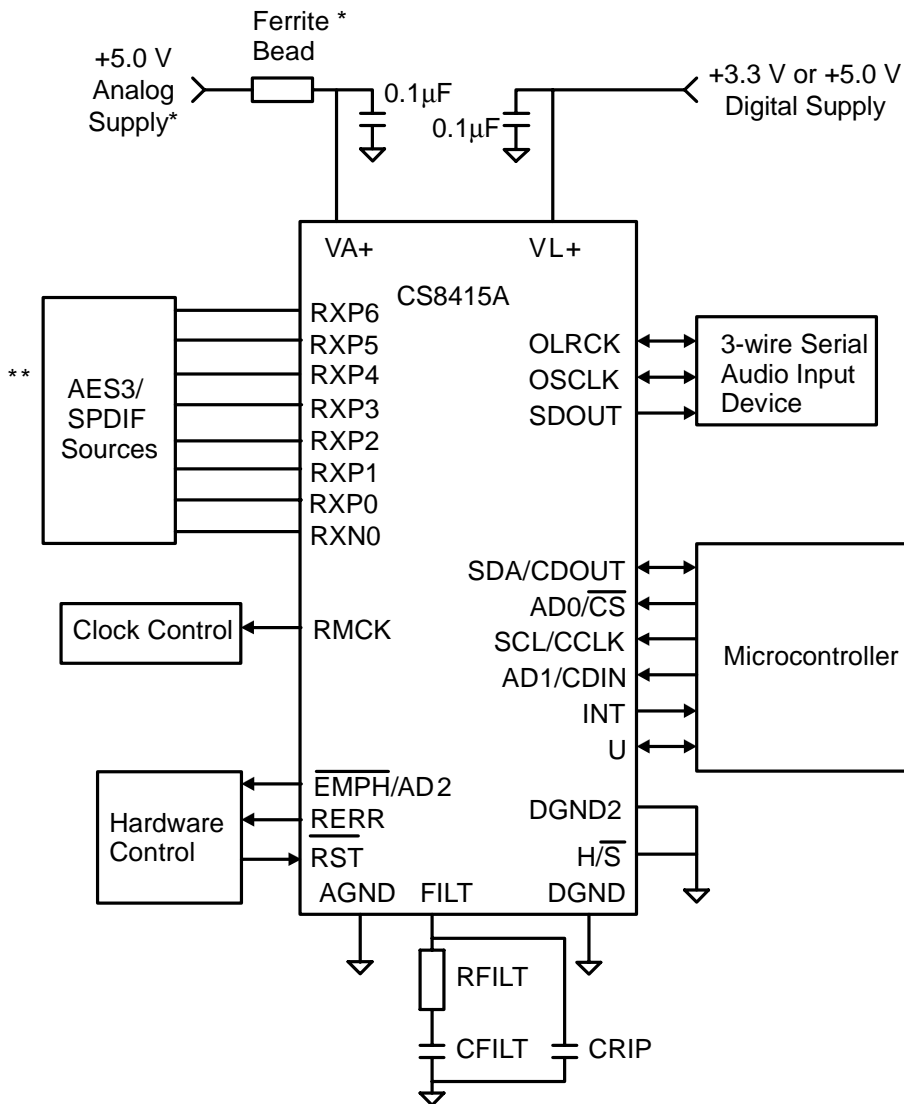

Figure 4. I²C Mode Timing

2. TYPICAL CONNECTION DIAGRAM



* A separate analog supply is only necessary in applications where RMCK is used for a jitter sensitive task. For applications where RMCK is not used for a jitter sensitive task, connect VA+ to VD+ via a ferrite bead. Keep the decoupling capacitor between VA+ and AGND.

** Please see section 5.1 "7:1 S/PDIF Input Multiplexer" and Appendix A for typical input configurations and recommended input circuits.

Figure 5. Recommended Connection Diagram for Software Mode

3. GENERAL DESCRIPTION

The CS8415A is a monolithic CMOS device which receives and decodes audio data according to the AES3, IEC60958, S/PDIF, and EIAJ CP1201 interface standards.

Input data is either differential or single-ended. A low-jitter clock is recovered from the incoming data using a PLL. The decoded audio data is output through a configurable, 3-wire output port. The channel status and user data are assembled in block-sized buffers and may be accessed through an SPI or I²C microcontroller port. For systems with no microcontroller, a stand-alone mode allows direct access to channel status and user data output pins.

Target applications include AVR, CD-R, DAT, DVD, multimedia speakers, MD and VTR equipment, mixing consoles, digital audio transmission and receiving equipment, high-quality D/A and A/D converters, effects processors, set-top boxes, and computer audio systems.

[Figure 5](#) shows the supply and external connections to the CS8415A, when configured for operation with a microcontroller.

3.1 AES3 and S/PDIF Standards Documents

This data sheet assumes that the user is familiar with the AES3 and S/PDIF data formats. It is advisable to have current copies of the AES3 and IEC60958 specifications on hand for easy reference.

The latest AES3 standard is available from the Audio Engineering Society or ANSI at www.aes.org or www.ansi.org. Obtain the latest IEC60958 standard from ANSI or from the International Electrotechnical Commission at www.iec.ch. The latest EIAJ CP-1201 standard is available from the Japanese Electronics Bureau.

Cirrus Logic Application Note 22: *Overview of Digital Audio Interface Data Structures* contains a useful tutorial on digital audio specifications, but it should not be considered a substitute for the standards.

The paper *An Understanding and Implementation of the SCMS Serial Copy Management System for Digital Audio Transmission*, by Clifton Sanchez, is an excellent tutorial on SCMS. It is available from the AES as preprint 3518.

4. SERIAL AUDIO OUTPUT PORT

A 3-wire serial audio output port is provided. The port can be adjusted to suit the attached device setting the control registers. The following parameters are adjustable: master or slave, serial clock frequency, audio data resolution, left or right justification of the data relative to left/right clock, optional one-bit cell delay of the first data bit, the polarity of the bit clock, and the polarity of the left/right clock. By setting the appropriate control bits, many formats are possible.

Figure 6 shows the selection of common output formats including the control bit settings. It should be noted that in right-justified mode, the serial audio output data is "MSB extended". This means that in a sub-frame where the MSB of the data is '1', all bits preceding the MSB in the sub-frame will also be '1'. Conversely, in a sub-frame where the MSB of the data is '0', all bits preceding the MSB in the sub-frame will also be '0'.

A special AES3 direct output format is included, which allows the serial output port access to the V, U, and C bits embedded in the serial audio data stream. The P bit is replaced by a Z bit that marks the subframe just prior to the start of each block. The received channel status block start signal is only available in hardware mode, as the RCBL pin.

In master mode, the left/right clock and the serial bit clock are outputs, derived from the recovered RMCK clock. In slave mode, the left/right clock and the serial bit clock are inputs. The left/right clock must be synchronous to the appropriate master clock, but the serial bit clock can be asynchronous and discontinuous if required. By appropriate phasing of the left/right clock and control of the serial clocks, multiple CS8415As can share one serial port. The left/right clock should be continuous, but the duty cycle can be less than the specified typical value of 50% if enough serial clocks are present in each phase to clock all the data bits. When in slave mode, the serial audio output port must not be set for right-justified data. When using the serial audio output port in slave mode with an OLRCK input which is asynchronous to the incoming AES3 data, an interrupt bit (OSLIP) is provided to indicate

when repeated or dropped samples occur. The CS8415A allows immediate mute of the serial audio output port audio data by the MUTESAO bit of Control Register 1.

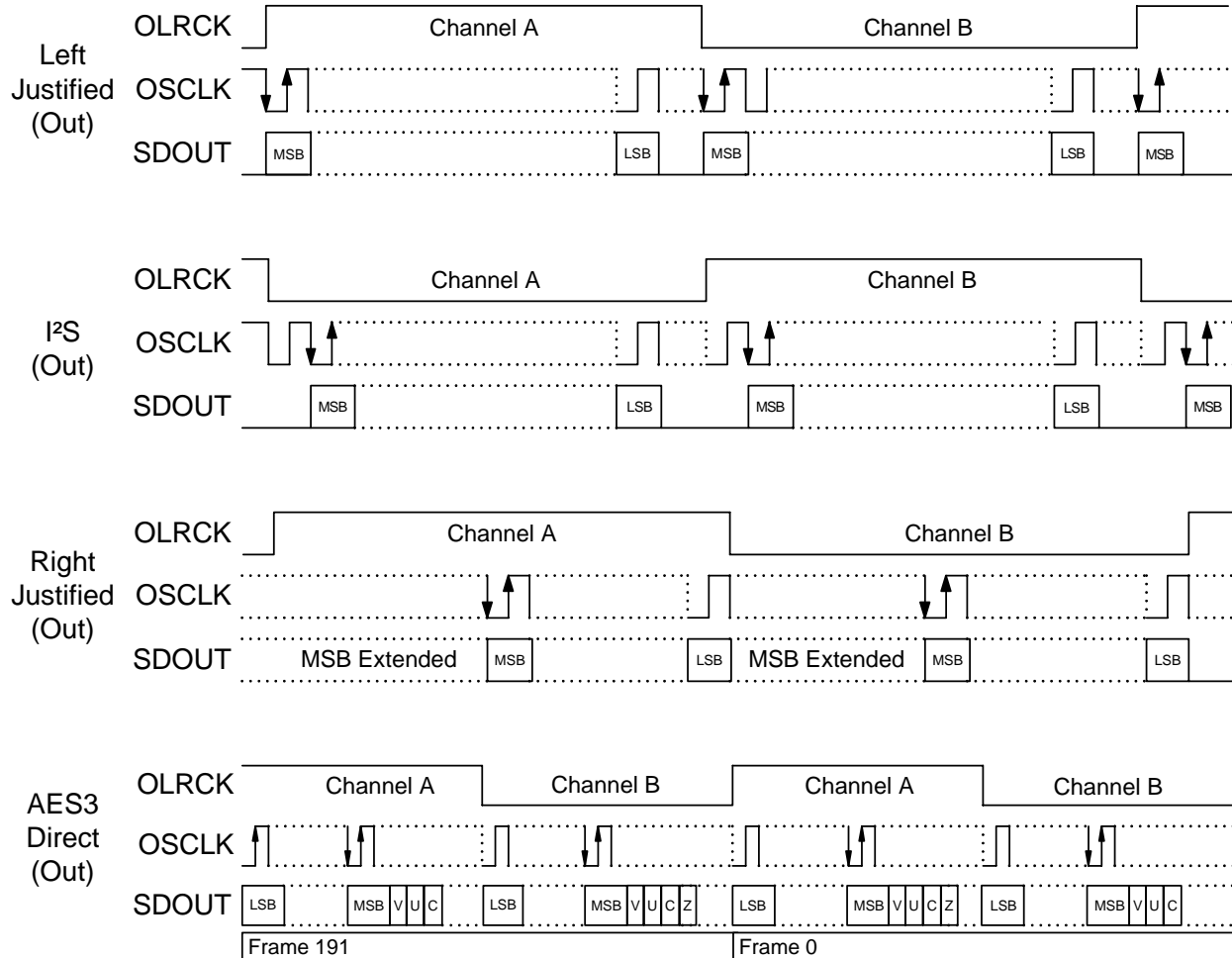

	SOMS*	SOSF*	SORES[1:0]*	SOJUST*	SODEL*	SOSPOL*	SOLRPOL*
Left Justified	X	X	XX	0	0	0	0
I ² S	X	X	XX	0	1	0	1
Right Justified	1	X	XX	1	0	0	0
AES3 Direct	X	X	11	0	0	0	0

X = don't care to match format, but does need to be set to the desired setting

* See Serial Output Data Format Register Bit Descriptions for an explanation of the meaning of each bit

Figure 6. Serial Audio Output Example Formats

5. AES3 RECEIVER

The CS8415A includes an AES3 digital audio receiver. A comprehensive buffering scheme provides read access to the channel status and user data. This buffering scheme is described in Appendix B.

The AES3 receiver accepts and decodes audio and digital data according to the AES3, IEC60958 (S/PDIF), and EIAJ CP-1201 interface standards. The receiver consists of a differential input stage, driven through pins RXP0 and RXN0, a PLL-based clock recovery circuit, and a decoder which separates the audio data from the channel status and user data.

External components are used to terminate and isolate the incoming data cables from the CS8415A. These components are detailed in Appendix A.

5.1 7:1 S/PDIF Input Multiplexer

The CS8415A employs a 7:1 S/PDIF Input Multiplexer to accommodate up to seven channels of input digital audio data. Digital audio data is single-ended and input through the RXP[0:6] pins. When any portion of the multiplexer is implemented, unused RXP pins should be tied to ground, and RXN0 must be AC-coupled to ground. The multiplexer select line control is accessed through bits MUX[2:0] in the Control 2 register. The multiplexer defaults to RXP0. Therefore, the default configuration is for a differential signal to be input through RXP0 & RXN0. Please see Appendix A for recommended input circuits.

5.2 OMCK System Clock Mode

A special clock switching mode is available that allows the clock that is input through the OMCK pin to be output through the RMCK pin. This feature is controlled by the SWCLK bit in register 1 of the control registers. When the PLL loses lock, the frequency of the VCO drops to 300 kHz. The clock switching mode allows the clock input through OMCK to be used as a clock in the system without any disruption when the PLL loses lock. For example, when the input is removed from the receiver. When SWCLK is enabled and this mode is implemented, RMCK is an output and is not bi-directional. This clock switching is performed glitch-free. Please note that internal circuitry associated with RMCK is not driven by OMCK. This means that OSCLK and OLRCK continue to be derived from the PLL and are not usable in this mode. This function is available only in software mode.

5.3 PLL, Jitter Attenuation, and Varispeed

Please see Appendix C for general description of the PLL, selection of recommended PLL filter components, and layout considerations. [Figure 5](#) shows the recommended configuration of the two capacitors and one resistor that comprise the PLL filter.

5.4 Error Reporting and Hold Function

While decoding the incoming AES3 data stream, the CS8415A can identify several kinds of error, indicated in the Receiver Error register. The UNLOCK bit indicates whether the PLL is locked to the incoming AES3 data. The V bit reflects the current validity bit status. The CONF (confidence) bit is the logical OR of BIP and UNLOCK. The BIP (bi-phase) error bit indicates an error in incoming bi-phase coding. The PAR (parity) bit indicates a received parity error.

The error bits are "sticky" - they are set on the first occurrence of the associated error and will remain set until the user reads the register through the control port. This enables the register to log all unmasked errors that occurred since the last time the register was read.

The Receiver Error Mask register allows masking of individual errors. The bits in this register serve as masks for the corresponding bits of the Receiver Error Register. If a mask bit is set to 1, the error is unmasked, which implies the following: its occurrence will be reported in the receiver error register, induce a

pulse on RERR, invoke the occurrence of a RERR interrupt, and affect the current audio sample according to the status of the HOLD bits. The HOLD bits allow a choice of holding the previous sample, replacing the current sample with zero (mute), or not changing the current audio sample. If a mask bit is set to 0, the error is masked, which implies the following: its occurrence will not be reported in the receiver error register, will not induce a pulse on RERR or generate a RERR interrupt, and will not affect the current audio sample. The QCRC and CCRC errors do not affect the current audio sample, even if unmasked.

5.5 Channel Status Data Handling

The first 2 bytes of the Channel Status block are decoded into the Receiver Channel Status register. The setting of the CHS bit in the Channel Status Data Buffer Control register determines whether the channel status decodes are from the A channel (CHS = 0) or B channel (CHS = 1).

The PRO (professional) bit is extracted directly. For consumer data, the COPY (copyright) bit is extracted, and the category code and L bits are decoded to determine SCMS status, indicated by the ORIG (original) bit. If the category code is set to General on the incoming AES3 stream, copyright will always be indicated even when the stream indicates no copyright. Finally, the AUDIO bit is extracted and used to set an AUDIO indicator, as described in the Non-audio Auto-detection section below.

If 50/15 μ s pre-emphasis is detected, the state of the $\overline{\text{EMPH}}$ pin is adjusted accordingly.

The encoded channel status bits which indicate sample word length are decoded according to AES3-1992 or IEC 60958. Audio data routed to the serial audio output port is unaffected by the word length settings and all 24 bits are passed on as received.

Appendix A describes the overall handling of Channel Status and User data.

5.6 User Data Handling

The incoming user data is buffered in a user accessible buffer. Received user data may also be output to the U pin under the control of a control register bit. Depending on the clocking options selected, there may not be a clock available to qualify the U data output. Figure 7 illustrates the timing. If the incoming user data bits have been encoded as Q-channel subcode, the data is decoded and presented in 10 consecutive register locations. An interrupt may be enabled to indicate the decoding of a new Q-channel block, which may be read through the control port.

5.7 Non-Audio Auto-Detection

An AES3 data stream may be used to convey non-audio data, thus it is important to know whether the incoming AES3 data stream is digital audio or not. This information is typically conveyed in channel status bit 1 (AUDIO), which is extracted automatically by the CS8415A. However, certain non-audio sources, such as AC-3® or MPEG encoders, may not adhere to this convention, and the bit may not be properly set. The CS8415A AES3 receiver can detect such non-audio data. This is accomplished by looking for a 96-bit sync code, consisting of 0x0000, 0x0000, 0x0000, 0x0000, 0xF872, and 0x4E1F. When the sync code is detected, an internal AUTODETECT signal will be asserted. If no additional sync codes are detected within the next 4096 frames, AUTODETECT will be de-asserted until another sync code is detected. The AUDIO bit in the Receiver Channel Status register is the logical OR of AUTODETECT and the received channel status bit 1. If non-audio data is detected, the data is still processed exactly as if it were normal audio. It is up to the user to mute the outputs as required.

5.8 Mono Mode Operation

An AES3 stream may be used in more than one way to transmit 96 kHz sample rate data. One method is to double the frame rate of the current format. This results in a stereo signal with a sample rate of 96 kHz, carried over a single twisted pair cable. An alternate method is implemented using the 2 sub-frames in a 48-kHz frame rate AES3 signal to carry consecutive samples of a mono signal, resulting in a 96-kHz sample rate stream. This allows older equipment, whose AES3 transmitters and receivers are not rated for 96-kHz frame rate operation, to handle 96-kHz sample rate information. In this “mono mode”, 2 AES3 cables are needed for stereo data transfer. The CS8415A offers mono mode operation, controlled through the MMR control register bit.

The receiver mono mode effectively doubles F_s compared to the input frame rate. The clock output on the RMCK pin tracks F_s , and so is doubled in frequency compared to stereo mode. The receiver will run at a frame rate of $F_s/2$, and the serial audio output port will run at F_s . Sub-frame A data will be routed to both the left and right data fields on SDOUT. Similarly, sub-frame B data will be routed to both the left and right data fields of the next word clock cycle of SDOUT.

Using mono mode is only necessary if the serial audio output port must run at 96 kHz. If the CS8415A is kept in normal stereo mode, and receives AES3 data arranged in mono mode, then the serial audio output port will run at 48 kHz, with left and right data fields representing consecutive audio samples.

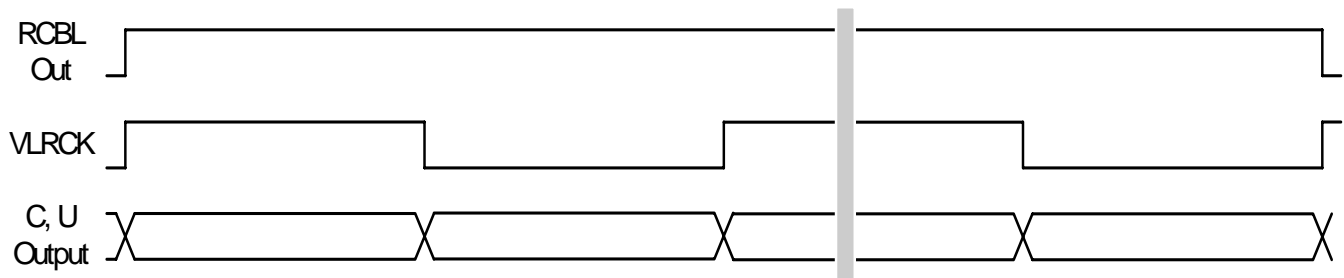

- RCBL and C output are only available in hardware mode.
- RCBL goes high 2 frames after receipt of a Z preamble, and is high for 16 frames.
- VLCK is a virtual word clock, which may not exist, but is used to illustrate the C/U timing.
- VLCK duty cycle is 50%. VLCK frequency is always equal to the incoming frame rate.
- If the serial audio output port is in master mode, VLCK = OLRCK
- If the serial audio output port is in slave mode, then VLCK needs to be externally created, if required.
- C and U transitions are aligned within $\pm 1\%$ of VLCK period to VLCK edges.

Figure 7. AES3 Receiver Timing for C & U Pin Output Data

6. CONTROL PORT DESCRIPTION AND TIMING

The control port is used to access the registers, allowing the CS8415A to be configured for the desired operational modes and formats. In addition, Channel Status and User data may be read through the control port. The operation of the control port may be completely asynchronous with respect to the audio sample rates. However, to avoid potential interference problems, the control port pins should remain static if no operation is required.

The control port has 2 modes: SPI and I²C, with the CS8415A acting as a slave device. SPI mode is selected if there is a high-to-low transition on the AD0/ \overline{CS} pin, after the \overline{RST} pin has been brought high. I²C mode is selected by connecting the AD0/ \overline{CS} pin to VL+ or DGND, thereby permanently selecting the desired AD0 bit address state.

6.1 SPI™ Mode

In SPI mode, \overline{CS} is the CS8415A chip select signal, CCLK is the control port bit clock (input into the CS8415A from the microcontroller), CDIN is the input data line from the microcontroller, CDOUT is the output data line to the microcontroller. Data is clocked in on the rising edge of CCLK and out on the falling edge.

Figure 8 shows the operation of the control port in SPI mode. To write to a register, bring \overline{CS} low. The first seven bits on CDIN form the chip address and must be 0010000b. The eighth bit is a read/write indicator (R/W), which should be low to write. The next eight bits form the Memory Address Pointer (MAP), which is set to the address of the register that is to be updated. The next eight bits are the data which will be placed into the register designated by the MAP. During writes, the CDOUT output stays in the Hi-Z state. It may be externally pulled high or low with a 47 k Ω resistor, if desired.

There is a MAP auto increment capability, enabled by the INCR bit in the MAP register. If INCR is a zero, the MAP will stay constant for successive read or writes. If INCR is set to a 1, the MAP will autoincrement after each byte is read or written, allowing block reads or writes of successive registers.

To read a register, the MAP has to be set to the correct address by executing a partial write cycle which finishes (\overline{CS} high) immediately after the MAP byte. The MAP auto increment bit (INCR) may be set or not, as desired. To begin a read, bring \overline{CS} low, send out the chip address and set the read/write bit (R/W) high. The next falling edge of CCLK will clock out the MSB of the addressed register (CDOUT will leave the high impedance state). If the MAP auto increment bit is set to 1, the data for successive registers will appear consecutively.

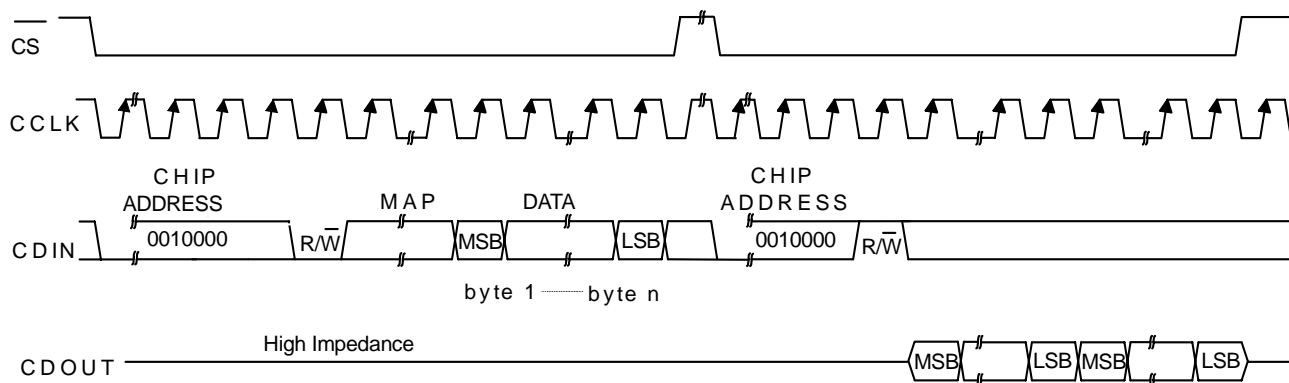

MAP = Memory Address Pointer, 8 bits, MSB first

Figure 8. Control Port Timing in SPI Mode

6.2 I²C Mode

In I²C mode, SDA is a bidirectional data line. Data is clocked into and out of the part by the clock, SCL, with the clock to data relationship as shown in Figure 9. There is no \overline{CS} pin. Each individual CS8415A is given a unique address. Pins AD0 and AD1 form the two least significant bits of the chip address and should be connected to VL+ or DGND as desired. The \overline{EMPH} pin is used to set the AD2 bit by connecting a resistor from the \overline{EMPH} pin to VL+ or to DGND. The state of the pin is sensed while the CS8415A is being reset. The upper 4 bits of the 7-bit address field are fixed at 0010b. To communicate with a CS8415A, the chip address field, which is the first byte sent to the CS8415A, should match 0010b followed by the settings of the \overline{EMPH} , AD1, and AD0. The eighth bit of the address is the R/W bit. If the operation is a write, the next byte is the Memory Address Pointer (MAP) which selects the register to be read or written. If the operation is a read, the contents of the register pointed to by the MAP will be output. Setting the auto increment bit in MAP allows successive reads or writes of consecutive registers. Each byte is separated by an acknowledge bit. The ACK bit is output from the CS8415A after each input byte is read, and is input to the CS8415A from the microcontroller after each transmitted byte. I²C mode is supported only with VL+ in 5V mode.

6.3 Interrupts

The CS8415A has a comprehensive interrupt capability. The INT output pin is intended to drive the interrupt input pin on the host microcontroller. The INT pin may be set to be active-low, active-high or active-low with no active pull-up transistor. This last mode is used for active-low, wired-OR hook-ups, with multiple peripherals connected to the microcontroller interrupt input pin.

Many conditions can cause an interrupt, as listed in the interrupt status register descriptions. Each source may be masked off through mask register bits. In addition, each source may be set to rising edge, falling edge, or level-sensitive. Combined with the option of level-sensitive or edge-sensitive modes within the microcontroller, many different configurations are possible, depending on the needs of the equipment designer.

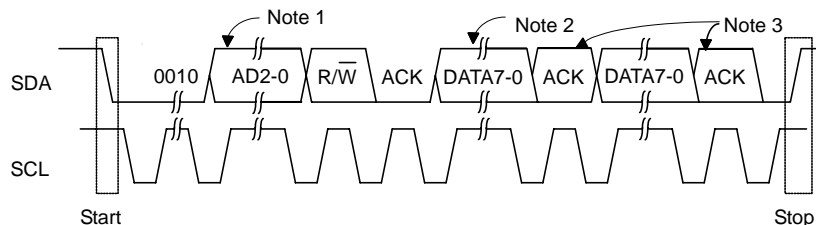

Figure 9. Control Port Timing in I²C Mode

Notes:

1. AD2 is derived from a resistor attached to the \overline{EMPH} pin. AD1 and AD0 are determined by the state of the corresponding pins.
2. If operation is a write, this byte contains the Memory Address Pointer, MAP.
3. If operation is a read, the last bit of the read should be NACK (high).

7. CONTROL PORT REGISTER SUMMARY

Addr (HEX)	Function	7	6	5	4	3	2	1	0
01	Control 1	SWCLK	0	MUTESAO	0	0	INT1	INT0	0
02	Control 2	0	HOLD1	HOLD0	RMCKF	MMR	MUX2	MUX1	MUX0
04	Clock Source Control	0	RUN	0	0	0	0	0	0
06	Serial Output Format	SOMS	SOSF	SORES1	SORES0	SOJUST	SODEL	SOSPOL	SOLRPOL
07	Interrupt 1 Status	0	OSLIP	0	0	0	DETC	0	RERR
08	Interrupt 2 Status	0	0	0	0	DETU	0	QCH	0
09	Interrupt 1 Mask	0	OSLIPM	0	0	0	DETCM	0	RERRM
0A	Interrupt 1 Mode (MSB)	0	OSLIP1	0	0	0	DETC1	0	RERR1
0B	Interrupt 1 Mode (LSB)	0	OSLIP0	0	0	0	DETC0	0	RERR0
0C	Interrupt 2 Mask	0	0	0	0	DETUM	0	QCHM	0
0D	Interrupt 2 Mode (MSB)	0	0	0	0	DETU1	0	QCH1	0
0E	Interrupt 2 Mode (LSB)	0	0	0	0	DETU0	0	QCH0	0
0F	Receiver CS Data	AUX3	AUX2	AUX1	AUX0	PRO	AUDIO	COPY	ORIG
10	Receiver Errors	0	QCRC	CCRC	UNLOCK	V	CONF	BIP	PAR
11	Receiver Error Mask	0	QCRCM	CCRCM	UNLOCKM	VM	CONFM	BIPM	PARM
12	CS Data Buffer Control	0	0	BSEL	CBMR	DETCI	0	CAM	CHS
13	U Data Buffer Control	0	0	0	0	0	0	DETUI	0
14-1D	Q sub-code Data								
1E	OMCK/RMCK Ratio	ORR7	ORR6	ORR5	ORR4	ORR3	ORR2	ORR1	ORR0
20-37	C or U Data Buffer								
7F	ID and Version	ID3	ID2	ID1	ID0	VER3	VER2	VER1	VER0

Table 1. Control Register Map Summary

7.1 Memory Address Pointer (MAP)

7	6	5	4	3	2	1	0
INCR	MAP6	MAP5	MAP4	MAP3	MAP2	MAP1	MAP0

INCR - Auto Increment Address Control Bit

Default = '0'

0 - Disabled

1 - Enabled

MAP6:MAP0 - Register address

Note: Reserved registers must not be written to during normal operation. Some reserved registers are used for test modes, which can completely alter the normal operation of the CS8415A.

8. CONTROL PORT REGISTER BIT DEFINITIONS

8.1 Control 1 (01h)

7	6	5	4	3	2	1	0
SWCLK	0	MUTESAO	0	0	INT1	INT0	0

SWCLK - Controls output of OMCK on RMCK when PLL loses lock

Default = '0'

- 0 - RMCK default function
- 1 - OMCK output on RMCK pin

MUTESAO - Mute control for the serial audio output port

Default = '0'

- 0 - Disabled
- 1 - Enabled

INT1:0 - Interrupt output pin (INT) control

Default = '00'

- 00 - Active high; high output indicates interrupt condition has occurred
- 01 - Active low, low output indicates an interrupt condition has occurred
- 10 - Open drain, active low. Requires an external pull-up resistor on the INT pin.
- 11 - Reserved

8.2 Control 2 (02h)

7	6	5	4	3	2	1	0
0	HOLD1	HOLD0	RMCKF	MMR	MUX2	MUX1	MUX0

HOLD1:0 - Determine how received audio sample is affected when a receiver error occurs

Default = '00'

- 00 - Hold the last valid audio sample
- 01 - Replace the current audio sample with 00 (mute)
- 10 - Do not change the received audio sample
- 11 - Reserved

RMCKF - Select recovered master clock output pin frequency.

Default = '0'

- 0 - RMCK is equal to $256 * F_s$
- 1 - RMCK is equal to $128 * F_s$

MMR - Select AES3 receiver mono or stereo operation

Default = '0'

- 0 - Normal stereo operation
- 1 - A and B subframes treated as consecutive samples of one channel of data. Data is duplicated to both left and right parallel outputs of the AES receiver block. The sample rate (F_s) is doubled compared to MMR=0

MUX2:0 - 7:1 S/PDIF Input Multiplexer Select Line Control

Default = '000'

- 000 - RXP0
- 001 - RXP1
- 010 - RXP2
- 011 - RXP3
- 100 - RXP4
- 101 - RXP5
- 110 - RXP6
- 111 - Reserved

8.3 Clock Source Control (04h)

7	6	5	4	3	2	1	0
0	RUN	0	0	0	0	0	0

This register configures the clock sources of various blocks. In conjunction with the Data Flow Control register, various Receiver/Transmitter/Transceiver modes may be selected.

RUN - Controls the internal clocks, allowing the CS8415A to be placed in a “powered down”, low current consumption, state.

Default = '0'

0 - Internal clocks are stopped. Internal state machines are reset. The fully static control port is operational, allowing registers to be read or changed. Reading and writing the U and C data buffers is not possible. Power consumption is low.

1 - Normal part operation. This bit must be written to the 1 state to allow the CS8415A to begin operation. All input clocks should be stable in frequency and phase when RUN is set to 1.

8.4 Serial Audio Output Port Data Format (06h)

7	6	5	4	3	2	1	0
SOMS	SOSF	SORES1	SORES0	SOJUST	SODEL	SOSPOL	SOLRPOL

SOMS - Master/Slave Mode Selector

Default = '0'

- 0 - Serial audio output port is in slave mode
- 1 - Serial audio output port is in master mode

SOSF - OSCLK frequency (for master mode)

Default = '0'

- 0 - 64*Fs
- 1 - 128*Fs

SORES1:0 - Resolution of the output data on SDOOUT

Default = '00'

- 00 - 24-bit resolution
- 01 - 20-bit resolution
- 10 - 16-bit resolution
- 11 - Direct copy of the received NRZ data from the AES3 receiver (including C, U, and V bits, the time slot

normally occupied by the P bit is used to indicate the location of the block start, SDOUT pin only, serial audio output port clock must be derived from the AES3 receiver recovered clock)

SOJUST - Justification of SDOUT data relative to OLRCK

Default = '0'

0 - Left-justified

1 - Right-justified (master mode only)

SODEL - Delay of SDOUT data relative to OLRCK, for left-justified data formats

Default = '0'

0 - MSB of SDOUT data occurs in the first OSCLK period after the OLRCK edge

1 - MSB of SDOUT data occurs in the second OSCLK period after the OLRCK edge

SOSPOL - OSCLK clock polarity

Default = '0'

0 - SDOUT sampled on rising edges of OSCLK

1 - SDOUT sampled on falling edges of OSCLK

SOLRPOL - OLRCK clock polarity

Default = '0'

0 - SDOUT data is for the left channel when OLRCK is high

1 - SDOUT data is for the right channel when OLRCK is high

8.5 Interrupt 1 Status (07h) (Read Only)

7	6	5	4	3	2	1	0
0	OSLIP	0	0	0	DETC	0	RERR

For all bits in this register, a "1" means the associated interrupt condition has occurred at least once since the register was last read. A "0" means the associated interrupt condition has NOT occurred since the last reading of the register. Reading the register resets all bits to 0, unless the interrupt mode is set to level and the interrupt source is still true. Status bits that are masked off in the associated mask register will always be "0" in this register. This register defaults to 00h.

OSLIP - Serial audio output port data slip interrupt

When the serial audio output port is in slave mode, and OLRCK is asynchronous to the port data source, This bit will go high every time a data sample is dropped or repeated.

DETC - D to E C-buffer transfer interrupt.

Indicates the completion of a D to E C-buffer transfer. See "Channel Status and User Data Buffer Management" on page 38 for more information.

RERR - A receiver error has occurred.

The Receiver Error register may be read to determine the nature of the error which caused the interrupt.

8.6 Interrupt 2 Status (08h) (Read Only)

7	6	5	4	3	2	1	0
0	0	0	0	DETU	0	QCH	0

For all bits in this register, a “1” means the associated interrupt condition has occurred at least once since the register was last read. A “0” means the associated interrupt condition has NOT occurred since the last reading of the register. Reading the register resets all bits to 0, unless the interrupt mode is set to level and the interrupt source is still true. Status bits that are masked off in the associated mask register will always be “0” in this register. This register defaults to 00h.

DETU - D to E U-buffer transfer interrupt.

Indicates the completion of a D to E U-buffer transfer. See “Channel Status and User Data Buffer Management” on page 38 for more information.

QCH - A new block of Q-subcode data is available for reading.

The data must be completely read within 588 AES3 frames after the interrupt occurs to avoid corruption of the data by the next block.

8.7 Interrupt 1 Mask (09h)

7	6	5	4	3	2	1	0
0	OSLIPM	0	0	0	DETCM	0	RERRM

The bits of this register serve as a mask for the Interrupt 1 register. If a mask bit is set to 1, the error is unmasked, meaning that its occurrence will affect the INT pin and the status register. If a mask bit is set to 0, the error is masked, meaning that its occurrence will not affect the INT pin or the status register. The bit positions align with the corresponding bits in Interrupt 1 register. This register defaults to 00h.

8.8 Interrupt 1 Mode MSB (0Ah) and Interrupt 1 Mode LSB (0Bh)

7	6	5	4	3	2	1	0
0	OSLIP1	0	0	0	DETC1	0	RERR1
0	OSLIP0	0	0	0	DETC0	0	RERR0

The two Interrupt Mode registers form a 2-bit code for each Interrupt Register 1 function. There are three ways to set the INT pin active in accordance with the interrupt condition. In the Rising edge active mode, the INT pin becomes active on the arrival of the interrupt condition. In the Falling edge active mode, the INT pin becomes active on the removal of the interrupt condition. In Level active mode, the INT interrupt pin becomes active during the interrupt condition. Be aware that the active level (Active High or Low) only depends on the INT[1:0] bits. These registers default to 00.

- 00 - Rising edge active
- 01 - Falling edge active
- 10 - Level active
- 11 - Reserved

8.9 Interrupt 2 Mask (0Ch)

7	6	5	4	3	2	1	0
0	0	0	0	DETUM	0	QCHM	0

The bits of this register serve as a mask for the Interrupt 2 register. If a mask bit is set to 1, the error is unmasked, meaning that its occurrence will affect the INT pin and the status register. If a mask bit is set to 0, the error is masked, meaning that its occurrence will not affect the INT pin or the status register. The bit positions align with the corresponding bits in Interrupt 2 register. This register defaults to 00h.

8.10 Interrupt 2 Mode MSB (0Dh) and Interrupt 2 Mode LSB (0Eh)

7	6	5	4	3	2	1	0
0	0	0	0	DETU1	0	QCH1	0
0	0	0	0	DETU0	0	QCH0	0

The two Interrupt Mode registers form a 2-bit code for each Interrupt Register 1 function. There are three ways to set the INT pin active in accordance with the interrupt condition. In the Rising edge active mode, the INT pin becomes active on the arrival of the interrupt condition. In the Falling edge active mode, the INT pin becomes active on the removal of the interrupt condition. In Level active mode, the INT interrupt pin becomes active during the interrupt condition. Be aware that the active level (Active High or Low) only depends on the INT[1:0] bits. These registers default to 00.

- 00 - Rising edge active
- 01 - Falling edge active
- 10 - Level active
- 11 - Reserved

8.11 Receiver Channel Status (0Fh) (Read Only)

7	6	5	4	3	2	1	0
AUX3	AUX2	AUX1	AUX0	PRO	AUDIO	COPY	ORIG

The bits in this register can be associated with either channel A or B of the received data. The desired channel is selected with the CHS bit of the Channel Status Data Buffer Control Register.

AUX3:0 - Incoming auxiliary data field width, as indicated by the incoming channel status bits, decoded according to IEC60958 and AES3.

- 0000 - Auxiliary data is not present
- 0001 - Auxiliary data is 1 bit long
- 0010 - Auxiliary data is 2 bits long
- 0011 - Auxiliary data is 3 bits long
- 0100 - Auxiliary data is 4 bits long
- 0101 - Auxiliary data is 5 bits long
- 0110 - Auxiliary data is 6 bits long
- 0111 - Auxiliary data is 7 bits long
- 1000 - Auxiliary data is 8 bits long
- 1001 - 1111 Reserved

PRO - Channel status block format indicator

- 0 - Received channel status block is in consumer format
- 1 - Received channel status block is in professional format

AUDIO - Audio indicator

- 0 - Received data is linearly coded PCM audio
- 1 - Received data is not linearly coded PCM audio

COPY - SCMS copyright indicator

- 0 - Copyright asserted
- 1 - Copyright not asserted

If the category code is set to General in the incoming AES3 stream, copyright will always be indicated by COPY, even when the stream indicates no copyright.

ORIG - SCMS generation indicator, decoded from the category code and the L bit.

- 0 - Received data is 1st generation or higher
- 1 - Received data is original

Note: COPY and ORIG will both be set to 1 if the incoming data is flagged as professional, or if the receiver is not in use.

8.12 Receiver Error (10h) (Read Only)

7	6	5	4	3	2	1	0
0	QCRC	CCRC	UNLOCK	V	CONF	BIP	PAR

This register contains the AES3 receiver and PLL status bits. Unmasked bits will go high on occurrence of the error, and will stay high until the register is read. Reading the register resets all bits to 0, unless the error source is still true. Bits that are masked off in the receiver error mask register will always be 0 in this register. This register defaults to 00h.

QCRC - Q-subcode data CRC error indicator. Updated on Q-subcode block boundaries

- 0 - No error
- 1 - Error

CCRC - Channel Status Block Cyclic Redundancy Check bit. Updated on CS block boundaries, valid in Pro mode

- 0 - No error
- 1 - Error

UNLOCK - PLL lock status bit. Updated on CS block boundaries.

- 0 - PLL locked
- 1 - PLL out of lock

V - Received AES3 Validity bit status. Updated on sub-frame boundaries.

- 0 - Data is valid and is normally linear coded PCM audio
- 1 - Data is invalid, or may be valid compressed audio

CONF - Confidence bit. Updated on sub-frame boundaries.

- 0 - No error
- 1 - Confidence error. This is the logical OR of BIP and UNLOCK.

BIP - Bi-phase error bit. Updated on sub-frame boundaries.

- 0 - No error
- 1 - Bi-phase error. This indicates an error in the received bi-phase coding.

PAR - Parity bit. Updated on sub-frame boundaries.

- 0 - No error
- 1 - Parity error

8.13 Receiver Error Mask (11h)

7	6	5	4	3	2	1	0
0	QCRCM	CCRCM	UNLOCKM	VM	CONFM	BIPM	PARM

The bits in this register serve as masks for the corresponding bits of the Receiver Error Register. If a mask bit is set to 1, the error is unmasked, meaning that its occurrence will appear in the receiver error register, will affect the RERR pin, will affect the RERR interrupt, and will affect the current audio sample according to the status of the HOLD bit. If a mask bit is set to 0, the error is masked, meaning that its occurrence will not appear in the receiver error register, will not affect the RERR pin, will not affect the RERR interrupt, and will not affect the current audio sample. The CCRC and QCRC bits behave differently from the other bits: they do not affect the current audio sample even when unmasked. This register defaults to 00h.

8.14 Channel Status Data Buffer Control (12h)

7	6	5	4	3	2	1	0
0	0	BSEL	CBMR	DETCI	0	CAM	CHS

BSEL - Selects the data buffer register addresses to contain User data or Channel Status data

Default = '0'

- 0 - Data buffer address space contains Channel Status data
- 1 - Data buffer address space contains User data

CBMR - Control for the first 5 bytes of channel status "E" buffer

Default = '0'

- 0 - Allow D to E buffer transfers to overwrite the first 5 bytes of channel status data
- 1 - Prevent D to E buffer transfers from overwriting first 5 bytes of channel status data

DETCI - D to E C-data buffer transfer inhibit bit.

Default = '0'

- 0 - Allow C-data D to E buffer transfers
- 1 - Inhibit C-data D to E buffer transfers

CAM - C-data buffer control port access mode bit

Default = '0'

- 0 - One byte mode
- 1 - Two byte mode

CHS - Channel select bit

Default = '0'

0 - Channel A information is displayed at the $\overline{\text{EMPH}}$ pin and in the receiver channel status register. Channel A information is output during control port reads when CAM is set to 0 (One Byte Mode)

1 - Channel B information is displayed at the $\overline{\text{EMPH}}$ pin and in the receiver channel status register. Channel B information is output during control port reads when CAM is set to 0 (One Byte Mode)

8.15 User Data Buffer Control (13h)

7	6	5	4	3	2	1	0
0	0	0	0	0	0	DETUI	0

DETUI - D to E U-data buffer transfer inhibit bit.

Default = '0'

- 0 - Allow U-data D to E buffer transfers
- 1 - Inhibit U-data D to E buffer transfers

8.16 Q-Channel Subcode Bytes 0 to 9 (14h - 1Dh) (Read Only)

The following 10 registers contain the decoded Q-channel subcode data

7	6	5	4	3	2	1	0
CONTROL	CONTROL	CONTROL	CONTROL	ADDRESS	ADDRESS	ADDRESS	ADDRESS
TRACK	TRACK	TRACK	TRACK	TRACK	TRACK	TRACK	TRACK
INDEX	INDEX	INDEX	INDEX	INDEX	INDEX	INDEX	INDEX
MINUTE	MINUTE	MINUTE	MINUTE	MINUTE	MINUTE	MINUTE	MINUTE
SECOND	SECOND	SECOND	SECOND	SECOND	SECOND	SECOND	SECOND
FRAME	FRAME	FRAME	FRAME	FRAME	FRAME	FRAME	FRAME
ZERO	ZERO	ZERO	ZERO	ZERO	ZERO	ZERO	ZERO
ABS MINUTE	ABS MINUTE	ABS MINUTE	ABS MINUTE	ABS MINUTE	ABS MINUTE	ABS MINUTE	ABS MINUTE
ABS SECOND	ABS SECOND	ABS SECOND	ABS SECOND	ABS SECOND	ABS SECOND	ABS SECOND	ABS SECOND
ABS FRAME	ABS FRAME	ABS FRAME	ABS FRAME	ABS FRAME	ABS FRAME	ABS FRAME	ABS FRAME

Each byte is LSB first with respect to the 80 Q-subcode bits Q[79:0]. Thus bit 7 of address 14h is Q[0] while bit 0 of address 0Eh is Q[7]. Similarly bit 0 of address 1Dh corresponds to Q[79].

8.17 OMCK/RMCK Ratio (1Eh) (Read Only)

7	6	5	4	3	2	1	0
ORR7	ORR6	ORR5	ORR4	ORR3	ORR2	ORR1	ORR0

This register allows the calculation of the incoming sample rate by the host microcontroller from the equation $ORR = F_{so}/F_{si}$. The F_{so} is determined by OMCK, whose frequency is assumed to be 256 F_{so} . ORR is represented as an unsigned 2-bit integer and a 6-bit fractional part. The value is meaningful only after the PLL has reached lock. For example, if the OMCK is 12.288 MHz, F_{so} would be 48 kHz (48 kHz = 12.288 MHz/256). Then if the input sample rate is also 48 kHz, you would get 1.0 from the ORR register. (The value from the ORR register is hexadecimal, so the actual value you will get is 40h). If $F_{so}/F_{si} > 3^{63}/64$, ORR will saturate at the value FFh. Also, there is no hysteresis on ORR. Therefore a small amount of jitter on either clock can cause the LSB ORR[0] to oscillate.

ORR7:6 - Integer part of the ratio (Integer value=Integer(SRR[7:6]))

ORR5:0 - Fractional part of the ratio (Fraction value=Integer(SRR[5:0])/64)

8.18 C-bit or U-bit Data Buffer (20h - 37h)

Either channel status data buffer E or user data buffer E is accessible through these register addresses.

8.19 CS8415A I.D. and Version Register (7Fh) (Read Only)

7	6	5	4	3	2	1	0
ID3	ID2	ID1	ID0	VER3	VER2	VER1	VER0

ID3:0 - ID code for the CS8415A. Permanently set to 0100

VER3:0 - CS8415A revision level. Revision A is coded as 0001

9. PIN DESCRIPTION - SOFTWARE MODE

SDA/CDOUT	1	28	SCL/CCLK
AD0/CS	2	27	AD1/CDIN
EMPH	3*+	26	RXP6
RXP0	4*	25	RXP5
RXN0	5*	*24	H/S
VA+	6*	*23	VL+
AGND	7*	*22	DGND
FILT	8*	*21	OMCK
RST	9*	20	U
RMCK	10*	19	INT
RERR	11*	*18	SDOUT
RXP1	12	*17	OLRCK
RXP2	13	*16	OSCLK
RXP3	14	15	RXP4

* Pins which remain the same function in all modes.

+ Pins which require a pull up or pull down resistor to select the desired startup option.

Pin Name	#	Pin Description
SDA/CDOUT	1	Serial Control Data I/O (I²C) / Data Out (SPI) (Input/Output) - In I ² C mode, SDA is the control I/O data line. SDA is open drain and requires an external pull-up resistor to VL+. In SPI mode, CDOUT is the output data from the control port interface on the CS8415A
AD0/CS	2	Address Bit 0 (I²C) / Control Port Chip Select (SPI) (Input) - A falling edge on this pin puts the CS8415A into SPI control port mode. With no falling edge, the CS8415A defaults to I ² C mode. In I ² C mode, AD0 is a chip address pin. In SPI mode, CS is used to enable the control port interface on the CS8415A
EMPH	3	Pre-Emphasis (Output) - EMPH is low when the incoming Channel Status data indicates 50/15 ms pre-emphasis. EMPH is high when the Channel Status data indicates no pre-emphasis or indicates pre-emphasis other than 50/15 ms. This is also a start-up option pin, and requires a 47 kΩ resistor to either VL+ or DGND, which determines the AD2 address bit for the control port in I ² C mode
RXP0 RXN0	4 5	AES3/SPDIF Receiver Port (Input) - Differential line receiver inputs carrying AES3 data. RXP0 may be used as a single-ended input as part of 7:1 S/PDIF Input MUX. If RXP0 is used in MUX, RXN0 must be ac coupled to ground.
RXP1 RXP2 RXP3 RXP4 RXP5 RXP6	12 13 14 15 25 26	Additional AES3/SPDIF Receiver Port (Input) - Single-ended receiver inputs carrying AES3 or S/PDIF digital data. These inputs, along with RXP0, comprise the 7:1 S/PDIF Input Multiplexer and select line control is accessed using the MUX2:0 bits in the Control 2 register. Please note that any unused inputs should be tied to ground. See Appendix A for recommended input circuits.
VA+	6	Positive Analog Power (Input) - Positive supply for the analog section. Nominally +5.0 V. This supply should be as quiet as possible since noise on this pin will directly affect the jitter performance of the recovered clock

Pin Name	#	Pin Description
AGND	7	Analog Ground (Input) - Ground for the analog circuitry in the chip. AGND and DGND should be connected to a common ground area under the chip.
FILT	8	PLL Loop Filter (Output) - An RC network should be connected between this pin and ground. See “Appendix C: PLL Filter” on page 41 for recommended schematic and component values.
RST	9	Reset (Input) - When RST is low, the CS8415A enters a low power mode and all internal states are reset. On initial power up, RST must be held low until the power supply is stable, and all input clocks are stable in frequency and phase. This is particularly true in hardware mode with multiple CS8415A devices where synchronization between devices is important
RMCK	10	Input Section Recovered Master Clock (Output) - Input section recovered master clock output when PLL is used. Frequency defaults to 256x the sample rate (Fs) and may be set to 128x.
RERR	11	Receiver Error (Output) - When high, indicates a problem with the operation of the AES3 receiver. The status of this pin is updated once per sub-frame of incoming AES3 data. Conditions that can cause RERR to go high are: validity, parity error, bi-phase coding error, confidence, QCRC and CCRC errors, as well as loss of lock in the PLL. Each condition may be optionally masked from affecting the RERR pin using the Receiver Error Mask Register. The RERR pin tracks the status of the unmasked errors: the pin goes high as soon as an unmasked error occurs and goes low immediately when all unmasked errors go away.
OSCLK	16	Serial Audio Output Bit Clock (Input/Output) - Serial bit clock for audio data on the SDOUT pin
OLRCK	17	Serial Audio Output Left/Right Clock (Input/Output) - Word rate clock for the audio data on the SDOUT pin. Frequency will be the output sample rate (Fs)
SDOUT	18	Serial Audio Output Data (Output) - Audio data serial output pin
INT	19	Interrupt (Output) - Indicates errors and key events during the operation of the CS8415A. All bits affecting INT may be unmasked through bits in the control registers. The condition(s) that initiated interrupt are readable through a control register. The polarity of the INT output, as well as selection of a standard or open drain output, is set through a control register. Once set true, the INT pin goes false only after the interrupt status registers have been read and the interrupt status bits have returned to zero
U	20	User Data (Output) - Outputs User data from the AES3 receiver, see Figure 7 for timing information
OMCK	21	System Clock (Input) - When the OMCK System Clock Mode is enabled using the SWCLK bit in the Control 1 register, the clock signal input on this pin is output through RMCK. OMCK serves as reference signal for OMCK/RMCK ratio expressed in register 1Eh
DGND	22	Digital Ground (Input) - Ground for the digital circuitry in the chip. DGND and AGND should be connected to a common ground area under the chip.
VL+	23	Positive Digital Power (Input) - Positive supply for the digital section. Typically +3.3 V or +5.0 V.
H/S ⁻	24	Hardware/Software Mode Control (Input) - Determines the method of controlling the operation of the CS8415A, and the method of accessing CS and U data. In software mode, device control and CS and U data access is primarily through the control port, using a microcontroller. Hardware mode provides an alternate mode of operation and access to the CS and U data through dedicated pins. This pin should be permanently tied to VL+ or DGND
AD1/CDIN	27	Address Bit 1 (I²C) / Serial Control Data in (SPI) (Input) - In I ² C mode, AD1 is a chip address pin. In SPI mode, CDIN is the input data line for the control port interface
SCL/CCLK	28	Control Port Clock (Input) - Serial control interface clock and is used to clock control data bits into and out of the CS8415A. In I ² C mode, SCL requires an external pull-up resistor to VL+

10.HARDWARE MODE

The CS8415A has a hardware mode which allows using the device without a microcontroller. Hardware mode is selected by connecting the H/S pin to VL+. Various pins change function in hardware mode, described in the hardware mode pin definition section.

Hardware mode data flow is shown in Figure 10. Audio data is input through the AES3 receiver, and routed to the serial audio output port. The PRO, COPY, ORIG, EMPH, and AUDIO channel status bits are output on pins. The decoded C and U bits are also output, clocked at both edges of OLRCK (master mode only, see Figure 7). The current audio sample is passed unmodified to the serial audio output port if the validity bit is high, or a parity, bi-phase, or PLL lock error occurs.

10.1 Serial Audio Port Formats

In hardware mode, only a limited number of alternative serial audio port formats are available. Table 2 defines the equivalent software mode bit settings for each format. Start-up options are shown in Table 3, and allow choice of the serial audio output port as a master or slave, and the serial audio port format.

	SOSF	SORES1/0	SOJUST	SODEL	SOSPOL	SOLRPOL
OF1 - Left Justified	0	00	0	0	0	0
OF2 - I ² S 24-bit data	0	00	0	1	0	1
OF3 - Right Justified, master mode only	0	00	1	0	0	0
OF4 - Direct AES3 data	0	11	0	0	0	0

Table 2. Equivalent Software Mode Bit Definitions

SDOUT	ORIG	EMPH	Function
LO	-	-	Serial Output Port is Slave
HI	-	-	Serial Output Port is Master
-	LO	LO	Left Justified
-	LO	HI	I ² S 24-bit data
-	HI	LO	Right Justified
-	HI	HI	Direct AES3 data

Table 3. Hardware Mode Start-Up Options

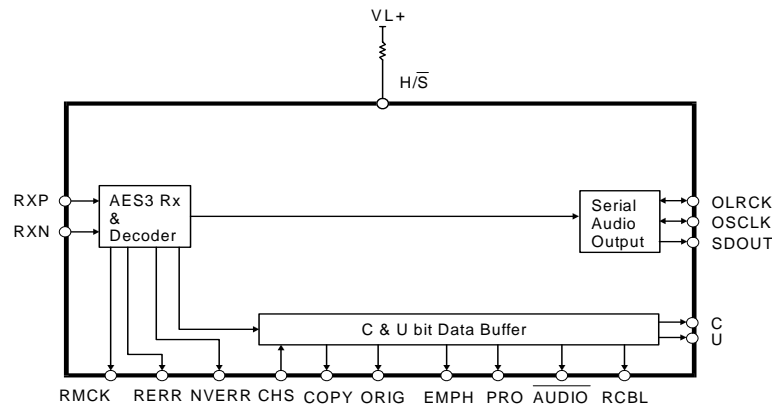

Power supply pins (VD+, VA+, DGND, AGND) & the reset pin (RST) and the PLL filter pin (FILT) are omitted from this diagram. Please refer to the Typical Connection Diagram for hook-up details.

Figure 10. Hardware Mode

11. PIN DESCRIPTION - HARDWARE MODE

COPY	□ 1	+28	□ ORIG
VL2+	□ 2	27	□ VL3+
EMPH	□ 3*+	26	□ C
RXP	□ 4*	25	□ U
RXN	□ 5*	*24	□ H/S
VA+	□ 6*	*23	□ VL+
AGND	□ 7*	*22	□ DGND
FILT	□ 8*	21	□ DGND2
RST	□ 9*	20	□ DGND3
RMCK	□ 10*	19	□ AUDIO
RERR	□ 11*	+*18	□ SDOUT
RCBL	□ 12	*17	□ OLRCK
PRO	□ 13	*16	□ OSCLK
CHS	□ 14	15	□ NVERR

- * Pins which remain the same function in all modes.
- + Pins which require a pull up or pull down resistor to select the desired startup option.

Pin Name	#	Pin Description
COPY	1	COPY Channel Status Bit (Output) - Reflects the state of the Copyright Channel Status bit in the incoming AES3 data stream. If the category code is set to General, copyright will be indicated whatever the state of the Copyright bit.
VL2+ VL+ VL3+	2 23 27	Positive Digital Power (Input) - Typically +3.3 V or +5.0 V.
EMPH	3	Pre-Emphasis (Output) - EMPH is low when the incoming Channel Status data indicates 50/15 ms pre-emphasis. EMPH is high when the Channel Status data indicates no pre-emphasis or indicates pre-emphasis other than 50/15 ms. This pin is also a start-up option which, along with ORIG, determines the serial port format. A 47 kΩ resistor to either VL+ or DGND is required.
RXP0 RXN0	4 5	AES3/SPDIF Receiver Port (Input) - Differential line receiver inputs for the AES3 biphas encoded data. See Appendix A for recommended circuits.
VA+	6	Positive Analog Power (Input) - Nominally +5.0 V. This supply should be as quiet as possible since noise on this pin will directly affect the jitter performance of the recovered clock.
AGND	7	Analog Ground (Input) - Ground for the analog circuitry in the chip. AGND and DGND should be connected to a common ground area under the chip.
FILT	8	PLL Loop Filter (Output) - An RC network should be connected between this pin and ground. See “Appendix C: PLL Filter” on page 41 for recommended schematic and component values.
RST	9	Reset (Input) - When RST is low, the CS8415A enters a low power mode and all internal states are reset. On initial power up, RST must be held low until the power supply is stable, and all input clocks are stable in frequency and phase. This is particularly true in hardware mode with multiple CS8415A devices where synchronization between devices is important.

Pin Name	#	Pin Description
RMCK	10	Recovered Master Clock (Output) - Recovered master clock output when PLL is locked to the incoming AES3 stream. Frequency is 256x the sample rate (Fs).
RERR	11	Receiver Error (Output) - When high, indicates an error condition in the AES3 receiver. The status of this pin is updated once per sub-frame of incoming AES3 data. Conditions that can cause RERR to go high are: validity bit high, parity error, bi-phase coding error, and loss of lock by the PLL.
RCBL	12	Receiver Channel Status Block (Output) - Indicates the beginning of a received channel status block. RCBL goes high two frames after the reception of a Z preamble, remains high for 16 frames while COPY, ORIG, AUDIO, EMPH and PRO are updated, and returns low for the remainder of the block. RCBL changes on rising edges of RMCK.
PRO	13	PRO Channel Status Bit (Output) - Reflects the state of the Professional/Consumer Channel Status bit in the incoming AES3 data stream. Low indicates Consumer and high indicates Professional.
CHS	14	Channel Select (Input) - Selects which sub-frame's channel status data is output on the EMPH, COPY, ORIG, PRO and AUDIO pins. Channel A is selected when CHS is low, channel B is selected when CHS is high.
NVERR	15	No Validity Receiver Error Indicator (Output) - A high output indicates a problem with the operation of the AES3 receiver. The status of this pin is updated once per frame of incoming AES3 data. Conditions that cause NVERR to go high are: parity error, and bi-phase coding error, and loss of lock by the PLL.
OSCLK	16	Serial Audio Output Bit Clock (Input/Output) - Serial bit clock for audio data on the SDOUT pin.
OLRCK	17	Serial Audio Output Left/Right Clock (Input/Output) - Word rate clock for the audio data on the SDOUT pin. Frequency will be the output sample rate (Fs).
SDOUT	18	Serial Audio Output Data (Output) - Audio data serial output pin. This pin is also a start-up option which determines if the serial audio port is master or slave. A 47 kΩ resistor to either VL+ or DGND is required.
AUDIO	19	Audio Channel Status Bit (Output) - Reflects the state of the audio/non audio Channel Status bit in the incoming AES3 data stream. When this bit is low a valid audio stream is indicated.
DGND3 DGND2 DGND	20 21 22	Digital Ground (Input) - Ground for the digital circuitry in the chip. DGND and AGND should be connected to a common ground area under the chip.
H/S	24	Hardware/Software Mode Control (Input) - Determines the method of controlling the operation of the CS8415A, and the method of accessing CS and U data. In software mode, device control and CS and U data access is primarily through the control port, using a microcontroller. Hardware mode provides an alternate mode of operation and access to the CS and U data through dedicated pins. This pin should be permanently tied to VL+ or DGND.
U	25	User Data (Output) - Outputs user data from the AES3 receiver, clocked by the rising and falling edges of OLRCK.
C	26	Channel Status Data (Output) - Outputs channel status data from the AES3 receiver, clocked by the rising and falling edges of OLRCK.
ORIG	28	Original Channel Status (Output) - SCMS generation indicator. This is decoded from the incoming category code and the L bit in the Channel Status bits. A low output indicates that the source of the audio data stream is a copy not an original. A high indicates that the audio data stream is original. This pin is also a start-up option which, along with EMPH, determines the serial audio port format. A 47 kΩ resistor to either VL+ or DGND is required.

12. APPLICATIONS

12.1 Reset, Power Down and Start-Up

When $\overline{\text{RST}}$ is low, the CS8415A enters a low-power mode and all internal states are reset, including the control port and registers, and the outputs are muted. When $\overline{\text{RST}}$ is high, the control port becomes operational and the desired settings should be loaded into the control registers. Writing a 1 to the RUN bit will then cause the part to leave the low-power state and begin operation. After the PLL has settled, the serial audio outputs will be enabled.

Some options within the CS8415A are controlled by a start-up mechanism. During the reset state, some of the output pins are reconfigured internally to be inputs. Immediately upon exiting the reset state, the level of these pins is sensed. The pins are then switched to be outputs. This mechanism allows output pins to be used to set alternative modes in the CS8415A by connecting a 47 k Ω resistor to between the pin and either VL+ (HI) or DGND (LO). For each mode, every start-up option select pin **MUST** have an external pull-up or pull-down resistor. In software mode, the only start-up option pin is EMPH, which is used to set a chip address bit for the control port in I²C mode. The hardware mode uses many start-up options, which are detailed in the hardware definition section at the end of this data sheet.

12.2 ID Code and Revision Code

The CS8415A has a register that contains a 4-bit code to indicate that the addressed device is a CS8415A. This is useful when other CS84xx family members are resident in the same system, allowing common software modules.

The CS8415A 4-bit revision code is also available. This allows the software driver for the CS8415A to identify which revision of the device is in a particular system, and modify its behavior accordingly. To allow for future revisions, it is strongly recommend that the revision code is read into a variable area within the microcontroller, and used wherever appropriate as revision details become known.

12.3 Power Supply, Grounding, and PCB Layout

For most applications, the CS8415A can be operated from a single +5.0 V supply, following normal supply decoupling practices. See [Figure 5](#). Note that the I²C protocol is supported only in VL+ = 5.0 V mode. For applications where the recovered input clock, output on the RMCK pin, is required to be low-jitter, then use a separate, quiet, analog +5.0 V supply for VA+, decoupled to AGND. In addition, a separate region of analog ground plane around the FILT, AGND, VA+, RXP[0:6] and RXN0 pins is recommended.

Extensive use of power and ground planes, ground plane fill in unused areas and surface mount decoupling capacitors are recommended. Decoupling capacitors should be mounted on the same side of the board as the CS8415A to minimize inductance effects, and all decoupling capacitors should be as close to the CS8415A as possible.

13. APPENDIX A: EXTERNAL AES3/SPDIF/IEC60958 RECEIVER COMPONENTS

13.1 AES3 Receiver External Components

The CS8415A AES3 receiver is designed to accept both the professional and consumer interfaces. The digital audio specifications for professional use call for a balanced receiver, using XLR connectors, with $110\ \Omega \pm 20\%$ impedance. The XLR connector on the receiver should have female pins with a male shell. Since the receiver has a very high input impedance, a $110\ \Omega$ resistor should be placed across the receiver terminals to match the line impedance, as shown in [Figure 11](#). Although transformers are not required by the AES, they are strongly recommended.

If some isolation is desired without the use of transformers, a $0.01\ \mu\text{F}$ capacitor should be placed in series with each input pin (RXPO and RXNO) as shown in [Figure 12](#). However, if a transformer is not used, high-frequency energy could be coupled into the receiver, causing degradation in analog performance.

[Figures 11](#) and [12](#) show an optional DC blocking capacitor ($0.1\ \mu\text{F}$ to $0.47\ \mu\text{F}$) in series with the cable input. This improves the robustness of the receiver, preventing the saturation of the transformer, or any DC current flow, if a DC voltage is present on the cable.

In the configuration of systems, it is important to avoid ground loops and DC current flowing down the shield of the cable that could result when boxes with different ground potentials are connected. Generally, it is good practice to ground the shield to the chassis of the transmitting unit, and connect the shield through a capacitor to chassis ground at the receiver. However, in some cases it is advantageous to have the ground of two boxes held to the same potential, and the cable shield might be depended upon to make that electrical connection. Generally, it may be a good idea to provide the option of grounding or capacitively coupling the shield to the chassis.

In the case of the consumer interface, the standards call for an unbalanced circuit having a receiver impedance of $75\ \Omega \pm 5\%$. The connector for the consumer interface is an RCA phono socket. The receiver circuit for the consumer interface is shown in [Figure 13](#). [Figure 14](#) shows an implementation of the input S/PDIF multiplexer using the consumer interface.

The circuit shown in [Figure 15](#) may be used when external RS422 receivers, optical receivers or other TTL/CMOS logic outputs drive the CS8415A receiver section.

13.2 Isolating Transformer Requirements

Please refer to the application note AN134: *AES and SPDIF Recommended Transformers* for resources on transformer selection.

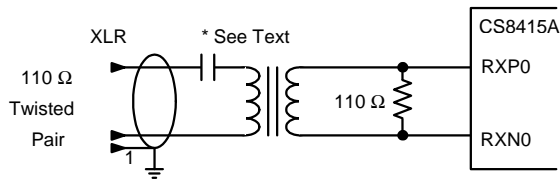

Figure 11. Professional Input Circuit

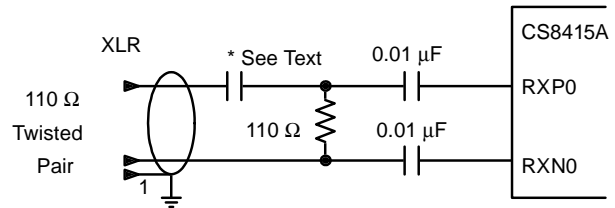

Figure 12. Transformerless Professional Input Circuit

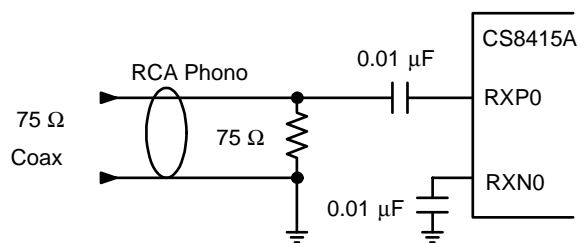

Figure 13. Consumer Input Circuit

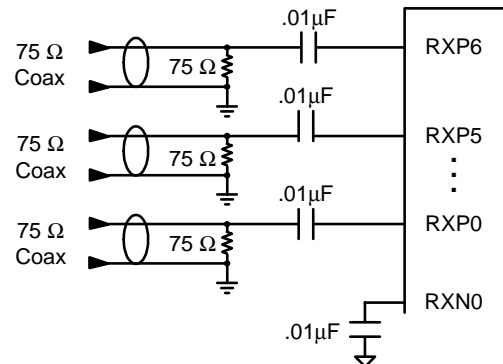

Figure 14. S/PDIF MUX Input Circuit

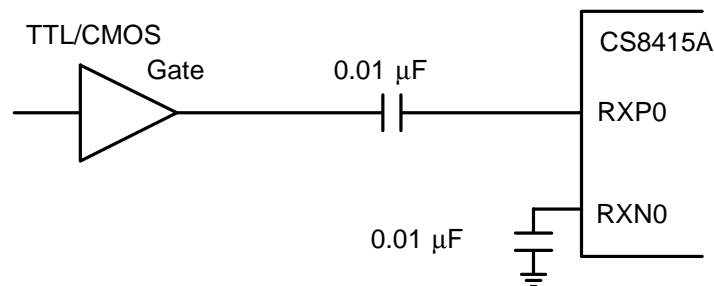

Figure 15. TTL/CMOS Input Circuit

14. APPENDIX B: CHANNEL STATUS AND USER DATA BUFFER MANAGEMENT

14.1 AES3 Channel Status (C) Bit Management

The CS8415A contains sufficient RAM to store a full block of C data for both A and B channels ($192 \times 2 = 384$ bits), and also 384 bits of U information. The user may read from these buffer RAMs through the control port.

The buffering scheme involves 2 block-sized buffers, named D and E, as shown in [Figure 16](#). The MSB of each byte represents the first bit in the serial C data stream. For example, the MSB of byte 0 (which is at control port address 20h) is the consumer/professional bit for channel status block A.

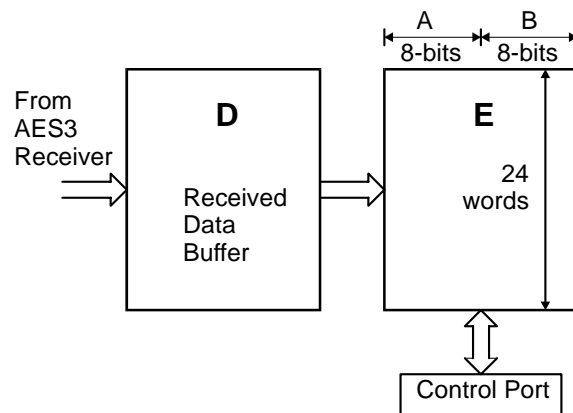

Figure 16. Channel Status Data Buffer Structure

The first buffer (D) accepts incoming C data from the AES receiver. The 2nd buffer (E) accepts entire blocks of data from the D buffer. The E buffer is also accessible from the control port, allowing reading of the C data.

14.2 Accessing the E Buffer

The user can monitor the incoming data by reading the E buffer, which is mapped into the register space of the CS8415A, through the control port.

The user can configure the interrupt enable register to cause interrupts to occur whenever D-to-E buffer transfers occur. This allows determination of the allowable time periods to interact with the E buffer.

Also provided is a D-to-E inhibit bit. This may be used whenever “long” control port interactions are occurring.

A flowchart for reading the E buffer is shown in [Figure 17](#). Since a D-to-E interrupt just occurred after reading, there is a substantial time interval until the next D-to-E transfer (approximately 24 frames worth of time). This is usually plenty of time to access the E data without having to inhibit the next transfer.

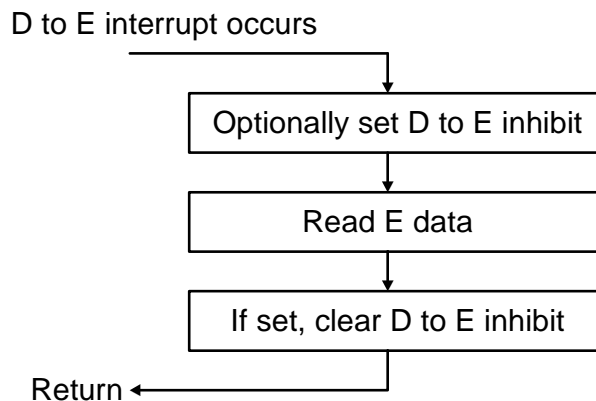

Figure 17. Flowchart for Reading the E Buffer

14.2.1 Reserving the First 5 Bytes in the E Buffer

D-to-E buffer transfers periodically overwrite the data stored in the E buffer. The CS8415A has the capability of reserving the first 5 bytes of the E buffer for user writes only. When this capability is in use, internal D-to-E buffer transfers will NOT affect the first 5 bytes of the E buffer. Therefore, the user can set values in these first 5 E bytes once, and the settings will persist until the next user change. This mode is enabled using the Channel Status Data Buffer Control register.

14.2.2 Serial Copy Management System (SCMS)

In software mode, the CS8415A allows read access to all the channel status bits. For consumer mode SCMS compliance, the host microcontroller needs to read and interpret the Category Code, Copy bit and L bit appropriately.

In hardware mode, the SCMS protocol can be followed by either using the COPY and ORIG output pins, or by using the C bit serial output pin. These options are documented in the hardware mode section of this data sheet.

14.2.3 Channel Status Data E Buffer Access

The E buffer is organized as 24 x 16-bit words. For each word the MS Byte is the A channel data, and the LS Byte is the B channel data (see [Figure 16](#)).

There are two methods of accessing this memory, known as one byte mode and two byte mode. The desired mode is selected by setting a control register bit.

14.2.3.1 One-Byte Mode

In many applications, the channel status blocks for the A and B channels will be identical. In this situation, if the user reads a byte from one of the channel's blocks, the corresponding byte for the other channel will be the same. One byte mode takes advantage of the often identical nature of A and B channel status data. When reading data in one byte mode, a single byte is returned, which can be from channel A or B data, depending on a register control bit.

One-byte mode saves the user substantial control port access time, as it effectively accesses 2 bytes worth of information in 1 byte's worth of access time. If the control port's autoincrement addressing is used in combination with this mode, multi-byte accesses such as full-block reads can be done especially efficiently.

14.2.3.2 Two-Byte Mode

There are those applications in which the A and B channel status blocks will not be the same, and the user is interested in accessing both blocks. In these situations, two-byte mode should be used to access the E buffer.

In this mode, a read will cause the CS8415A to output two bytes from its control port. The first byte out will represent the A channel status data, and the 2nd byte will represent the B channel status data.

14.3 AES3 User (U) Bit Management

Entire blocks of U data are buffered using a cascade of 2 block-sized RAMs to perform the buffering. The user has access to the second of these buffers, denoted the E buffer, through the control port. The U buffer access only operates in two-byte mode, since there is no concept of A and B blocks for user data. The arrangement of the data is as followings: Bit15[A7]Bit14[B7]Bit13[A6]Bit12[B6]...Bit1[A0]Bit0[B0]. The arrangement of the data in the each byte is that the MSB is the first received bit and is the first transmitted bit. The first byte read is the first byte received, and the first byte sent is the first byte transmitted. If you read two bytes from the E buffer, you will get the following arrangement: A[7]B[7]A[6]B[6]....A[0]B[0].

15.APPENDIX C: PLL FILTER

15.1 General

An on-chip Phase Locked Loop (PLL) is used to recover the clock from the incoming data stream. [Figure 18](#) is a simplified diagram of the PLL in these parts. When the PLL is locked to an AES3 input stream, it is updated at each preamble in the AES3 stream. This occurs at twice the sampling frequency, F_S . When the PLL is locked to ILRCK, it is updated at F_S so that the duty cycle of the input doesn't affect jitter.

There are some applications where low-jitter in the recovered clock, presented on the RMCK pin, is important. For this reason, the PLL has been designed to have good jitter attenuation characteristics, as shown in [Figure 21](#), [Figure 22](#), [Figure 23](#), and [Figure 24](#). In addition, the PLL has been designed to only use the preambles of the AES3 stream to provide lock update information to the PLL. This results in the PLL being immune to data-dependent jitter affects because the AES3 preambles do not vary with the data.

The PLL has the ability to lock onto a wide range of input sample rates with no external component changes. If the sample rate of the input subsequently changes, for example in a varispeed application, the PLL will only track up to $\pm 12.5\%$ from the nominal center sample rate. The nominal center sample rate is the sample rate that the PLL first locks onto upon application of an AES3 data stream or after enabling the CS8415A clocks by setting the RUN control bit. If the 12.5% sample rate limit is exceeded, the PLL will return to its wide lock range mode and re-acquire a new nominal center sample rate.

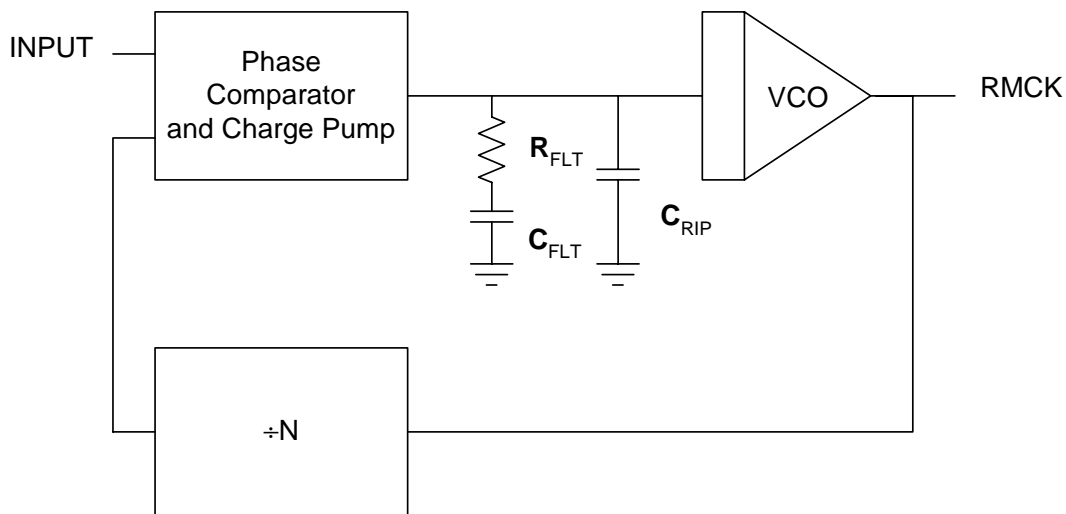

Figure 18. PLL Block Diagram

15.2 External Filter Components

15.2.1 General

The PLL behavior is affected by the external filter component values. [Figure 5 on page 11](#) shows the recommended configuration of the two capacitors and one resistor that comprise the PLL filter. In [Table 6](#), the component values shown have the highest corner frequency jitter attenuation curve, takes the shortest time to lock, and offers the best output jitter performance. The component values shown in [Table 5](#) allows the lowest input sample rate to be 8 kHz, and increases the lock time of the PLL. Lock times are worst case for an Fsi transition of 96 kHz.

15.2.2 Capacitor Selection

The type of capacitors used for the PLL filter can have a significant effect on receiver performance. Large or exotic film capacitors are not necessary as their leads and the required longer circuit board traces add undesirable inductance to the circuit. Surface mount ceramic capacitors are a good choice because their own inductance is low, and they can be mounted close to the FILT pin to minimize trace inductance. For C_{RIP} , a COG or NPO dielectric is recommended, and for C_{FLT} , an X7R dielectric is preferred. Avoid capacitors with large temperature coefficients, or capacitors with high dielectric constants, that are sensitive to shock and vibration. These include the Z5U and Y5V dielectrics.

15.2.3 Circuit Board Layout

Board layout and capacitor choice affect each other and determine the performance of the PLL. [Figure 19](#) contains a suggested layout for the PLL filter components and for bypassing the analog supply voltage. The 0.1 μF bypass capacitor is in a 1206 form factor. R_{FLT} and the other three capacitors are in an 0805 form factor. The traces are on the top surface of the board with the IC so that there is no via inductance. The traces themselves are short to minimize the inductance in the filter path. The VA+ and AGND traces extend back to their origin and are shown only in truncated form in the drawing.

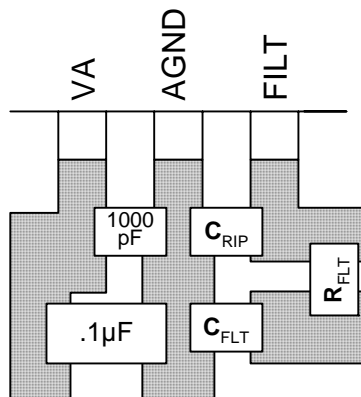

Figure 19. Recommended Layout Example

15.3 Component Value Selection

When transitioning from one revision of the part another, component values may need to be changed. While it is mandatory for customers to change the external PLL component values when transitioning from revision A to revision A1 or from revision A to revision A2, customers do not need to change external PLL component values when transitioning from revision A1 to revision A2, unless the part is used in an application that is required to pass the AES3 or IEC60958-4 specification for receiver jitter tolerance (see [Table 6](#)).

15.3.1 Identifying the Part Revision

The first line of the part marking on the package indicates the part number and package type (CS8415A-xx). [Table 4](#) shows a list of part revisions and their corresponding second line part marking, which indicates what revision the part is.

Revision	Pre-October 2002 SOIC & TSSOP (10-Digit)	New SOIC (12-Digit)	New TSSOP (10-Digit)
A	Zxxxxxxxxx	ZFBAAxxxxxxxx	NAAXxxxxxxxx
A1	Rxxxxxxxxx	RFBAA1xxxxxxxx	NAA1xxxxxxxx
A2	N/A	RFBAA2xxxxxxxx	NAA2xxxxxxxx

Table 4. Second Line Part Marking

15.3.2 External Components

Shown in [Table 5](#) and [Table 6](#) are the external PLL component values for each revision. Values listed for the 32 to 96 kHz F_s range will have the highest corner frequency jitter attenuation curve, take the shortest time to lock, and offer the best output jitter performance.

Revision	R_{FILT} (k Ω)	C_{FILT} (μ F)	C_{RIP} (nF)	PLL Lock Time (ms)
A	0.909	1.8	33	56
A1	0.4	0.47	47	60
A2	0.4	0.47	47	60

Table 5. $F_s = 8$ to 96 kHz

Revision	R_{FILT} (k Ω)	C_{FILT} (μ F)	C_{RIP} (nF)	PLL Lock Time (ms)
A*	3.0	0.047	2.2	35
A1*	1.2	0.1	4.7	35
A2	1.2	0.1	4.7	35
A2*	1.6	0.33	4.7	35

Table 6. $F_s = 32$ to 96 kHz

* Parts used in applications that are required to pass the AES3 or IEC60958-4 specification for receiver jitter tolerance should use these component values. Please note that the AES3 and IEC60958 specifications do not have allowances for locking to sample rates less than 32 kHz. Also note that many factors can affect jitter performance in a system. Please follow the circuit and layout recommendations outlined previously.

15.3.3 Jitter Tolerance

Shown in [Figure 20](#) is the Receiver Jitter Tolerance template as illustrated in the AES3 and IEC60958-4 specification. CS8415A parts used with the appropriate external PLL component values (as noted in [Table 6](#)) have been tested to pass this template.

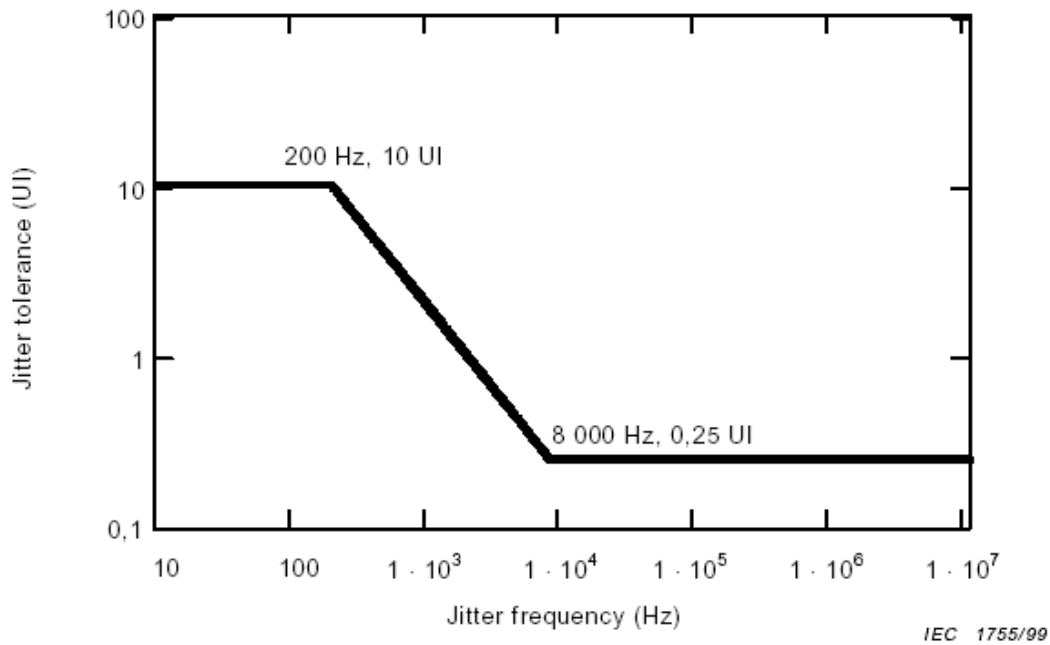

Figure 20. Jitter Tolerance Template

15.3.4 Jitter Attenuation

Shown in [Figure 21](#), [Figure 22](#), [Figure 23](#), and [Figure 24](#) are jitter attenuation plots for the various revisions of the CS8415A when used with the appropriate external PLL component values (as noted in [Table 6](#)). The AES3 and IEC60958-4 specifications do not have allowances for locking to sample rates less than 32 kHz. These specifications state a maximum of 2 dB jitter gain or peaking.

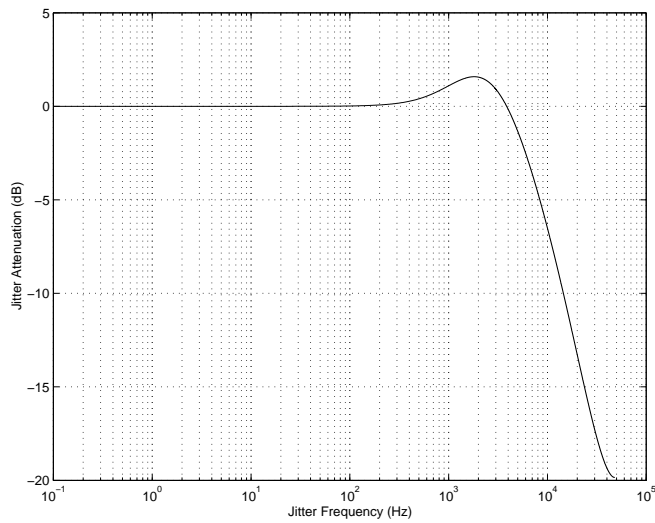

Figure 21. Revision A

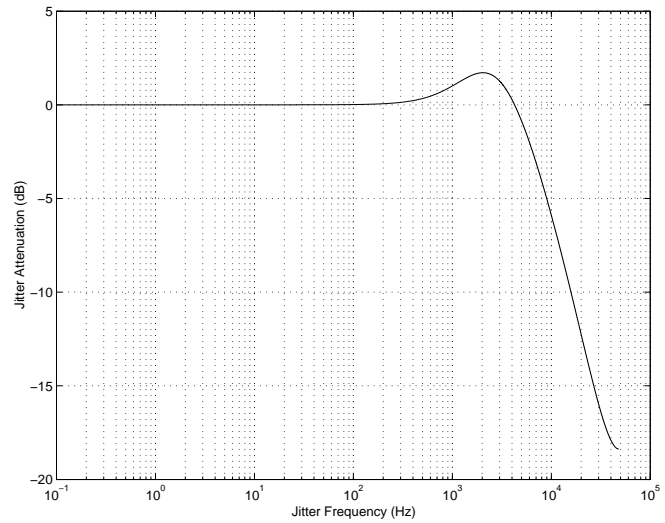

Figure 22. Revision A1

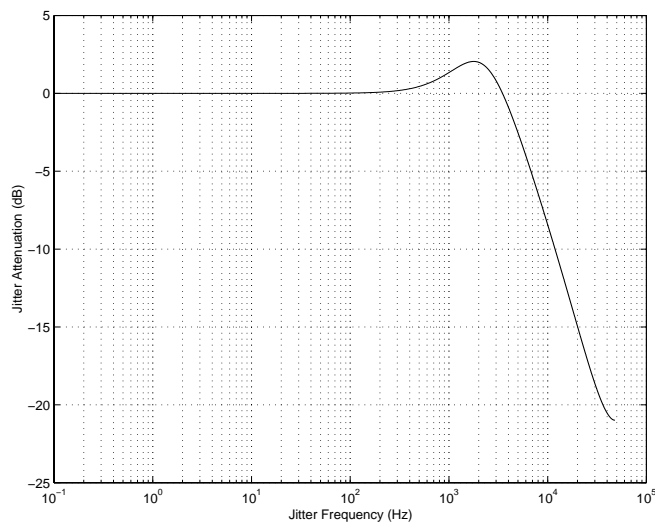

Figure 23. Revision A2 using A1 Values

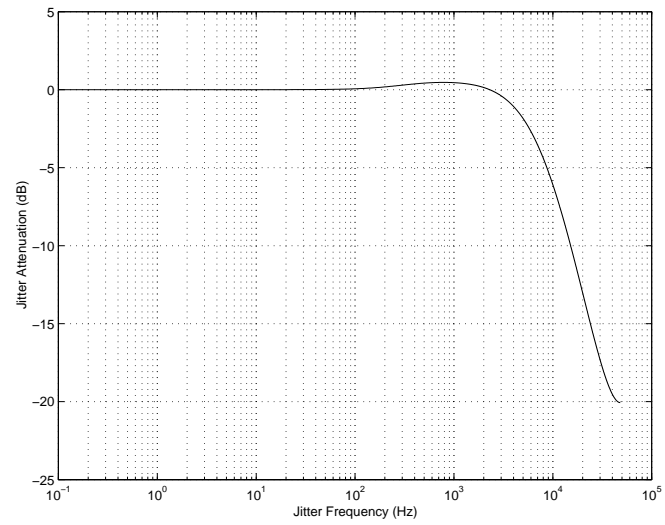

Figure 24. Revision A2 using A2* Values

16. REVISION HISTORY

Release	Date	Changes
PP1	November 1999	1st Preliminary Release
PP2	November 2000	2nd Preliminary Release
PP3	May 2001	3rd Preliminary Release
PP4	January 2003	4th Preliminary Release
F1	January 2004	Final Release Updated "Appendix C: PLL Filter" on page 41 to include information from errata ER470E2
F2	August 2004	-Added lead-free device ordering information.
F3	December 2004	-Changed format of Figure 6 on page 14. -Corrected AES3 Direct (Out) format in Figure 6 on page 14 and text reference to AES3 Direct on page 13. -Corrected bit 0 of register 04h to default to 0 on page 22. -Changed description of DETC and DETU bits in "Control Port Register Bit Definitions" on page 21. -Removed reference to Block Mode from DETU and DETUI on page 24 and page 27.
F4	August 2005	-Updated "Ordering Information" on page 2.

Contacting Cirrus Logic Support

For all product questions and inquiries contact a Cirrus Logic Sales Representative.

To find the one nearest to you go to www.cirrus.com

IMPORTANT NOTICE

Cirrus Logic, Inc. and its subsidiaries ("Cirrus") believe that the information contained in this document is accurate and reliable. However, the information is subject to change without notice and is provided "AS IS" without warranty of any kind (express or implied). Customers are advised to obtain the latest version of relevant information to verify, before placing orders, that information being relied on is current and complete. All products are sold subject to the terms and conditions of sale supplied at the time of order acknowledgment, including those pertaining to warranty, indemnification, and limitation of liability. No responsibility is assumed by Cirrus for the use of this information, including use of this information as the basis for manufacture or sale of any items, or for infringement of patents or other rights of third parties. This document is the property of Cirrus and by furnishing this information, Cirrus grants no license, express or implied under any patents, mask work rights, copyrights, trademarks, trade secrets or other intellectual property rights. Cirrus owns the copyrights associated with the information contained herein and gives consent for copies to be made of the information only for use within your organization with respect to Cirrus integrated circuits or other products of Cirrus. This consent does not extend to other copying such as copying for general distribution, advertising or promotional purposes, or for creating any work for resale.

CERTAIN APPLICATIONS USING SEMICONDUCTOR PRODUCTS MAY INVOLVE POTENTIAL RISKS OF DEATH, PERSONAL INJURY, OR SEVERE PROPERTY OR ENVIRONMENTAL DAMAGE ("CRITICAL APPLICATIONS"). CIRRUS PRODUCTS ARE NOT DESIGNED, AUTHORIZED OR WARRANTED FOR USE IN AIRCRAFT SYSTEMS, MILITARY APPLICATIONS, PRODUCTS SURGICALLY IMPLANTED INTO THE BODY, AUTOMOTIVE SAFETY OR SECURITY DEVICES, LIFE SUPPORT PRODUCTS OR OTHER CRITICAL APPLICATIONS. INCLUSION OF CIRRUS PRODUCTS IN SUCH APPLICATIONS IS UNDERSTOOD TO BE FULLY AT THE CUSTOMER'S RISK AND CIRRUS DISCLAIMS AND MAKES NO WARRANTY, EXPRESS, STATUTORY OR IMPLIED, INCLUDING THE IMPLIED WARRANTIES OF MERCHANTABILITY AND FITNESS FOR PARTICULAR PURPOSE, WITH REGARD TO ANY CIRRUS PRODUCT THAT IS USED IN SUCH A MANNER. IF THE CUSTOMER OR CUSTOMER'S CUSTOMER USES OR PERMITS THE USE OF CIRRUS PRODUCTS IN CRITICAL APPLICATIONS, CUSTOMER AGREES, BY SUCH USE, TO FULLY INDEMNIFY CIRRUS, ITS OFFICERS, DIRECTORS, EMPLOYEES, DISTRIBUTORS AND OTHER AGENTS FROM ANY AND ALL LIABILITY, INCLUDING ATTORNEYS' FEES AND COSTS, THAT MAY RESULT FROM OR ARISE IN CONNECTION WITH THESE USES.

Cirrus Logic, Cirrus, and the Cirrus Logic logo designs are trademarks of Cirrus Logic, Inc. All other brand and product names in this document may be trademarks or service marks of their respective owners.

SPI is a trademark of Motorola Inc.

AC-3 is a registered trademark of Dolby Laboratories Licensing, Inc.

Mouser Electronics

Authorized Distributor

Click to View Pricing, Inventory, Delivery & Lifecycle Information:

[Cirrus Logic:](#)

[CS8415A-IZZR](#) [CS8415A-CZZ](#) [CS8415A-CZZR](#) [CS8415A-CSZ](#) [CS8415A-CSZR](#)