



SMART  
Storage  
Products

Product Specification

**SMART Modular  
Small Form Factor USB Key**

**SLC NAND  
SH9MKxxGQxx**

August 2015 Rev E



[www.smartm.com](http://www.smartm.com)

## REVISION HISTORY

Date	Revision	Section(s)	Description
June 2014	A	All	Initial release
October 2014	B	1.4.1, 1.4.2, 2.2, 4.2, 4.4, & 7.0	Remove Endurance section and update maximum active current value for consistency. Remove geometry from Table 17. Add support for MLC-based NAND products.
November 2014	C	Table 5	Update to dimensions to comply with mechanical specification
May 2015	D	7.0 and Table 11	Specify SLC-based parts only and update product ID field.
August 2015	E	7.0	Update Part Numbers and add new extended capacity.



### ESD Caution – Handling

Static electricity may be discharged through this disk subsystem. In extreme cases, this may temporarily interrupt the operation or damage components. To prevent this, make sure you are working in an ESD-safe environment. For example, before handling the disk subsystem, touch a grounded device, such as a computer case, prior to handling.

This document is subject to change without notice.

### SMART Modular Technologies

39870 Eureka Dr.  
Newark, CA 94560

## TABLE OF CONTENTS

<b>1.0</b>	<b>General Description</b> . . . . .	<b>1</b>	<b>4.4</b>	<b>DC Characteristics</b> . . . . .	<b>10</b>
	1.1 Overview . . . . .	1	<b>5.0</b>	<b>USB Commands</b> . . . . .	<b>10</b>
	1.2 Features. . . . .	2	5.1	Standard Descriptor . . . . .	10
	1.3 Unique Features . . . . .	3	5.2	Device Descriptor . . . . .	11
	1.4 Operational Characteristics. . . . .	4	5.3	Configuration Descriptor . . . . .	12
	1.4.1 Performance . . . . .	4	5.4	Bulk-Only Data Interface Descriptor .	13
	1.4.2 Reliability . . . . .	4	5.5	Endpoint Descriptors . . . . .	14
	1.4.3 Power Requirements . . . . .	4		5.5.1 Bulk-In Endpoint Descriptor . . . . .	14
	1.4.4 Environmental Conditions . . . . .	5		5.5.2 Bulk-Out Endpoint Descriptor . . .	14
	1.4.5 Physical Characteristics . . . . .	5	<b>6.0</b>	<b>Reduced Block Commands (RBC)</b>	
<b>2.0</b>	<b>Product Description</b> . . . . .	<b>6</b>		<b>Descriptors</b>	<b>15</b>
	2.1 Functional Block Diagram . . . . .	6	<b>7.0</b>	<b>Part Numbers</b> . . . . .	<b>16</b>
	2.2 Mean Time Between Failures (MTBF). 7		7.1	Part Numbering Information . . . . .	16
<b>3.0</b>	<b>Mechanical Specification</b> . . . . .	<b>8</b>	7.2	Part Number Decoder. . . . .	17
<b>4.0</b>	<b>Electrical Specification</b> . . . . .	<b>9</b>	<b>8.0</b>	<b>Product Label</b> . . . . .	<b>19</b>
	4.1 Electrical Interface . . . . .	9			
	4.1.1 Mating Connector . . . . .	9			
	4.1.2 Pinout Descriptions . . . . .	9			
	4.2 Absolute Maximum Ratings. . . . .	9			
	4.3 Recommended Operating Conditions 9				

---

## 1.0 GENERAL DESCRIPTION

### 1.1 Overview

The SMART Modular Small Form Factor USB Memory Keys provide low power, high capacity mass storage for embedded applications. The USB memory keys use an injection molding process to fit the smallest form factor requirements. The USB Memory key acts like a hard drive, but has the transportability of a solid state device.

The USB SLC Memory key is available in capacities of 1 GBytes to 32 GBytes and is designed for applications requiring the high reliability and performance.

SMART Modular Small Form Factor USB Memory keys address the need for enhanced reliability by incorporating on-board error detection and correction, with global wear leveling algorithms that provide reliable operation over the product life cycle. These USB Memory keys offer sustained read performance up to 34 MBytes/sec and sustained write performance of up to 29 MBytes/sec.

SMART has built its foundation by providing proven technology and quality products to the most demanding Fortune 100 OEMs. SMART engineers its products to perform at the highest degree of reliability and compatibility while backing these products with outstanding services and technology expertise.

---

## 1.2 Features

- **Type:** Internal flash-based USB memory key module
- **Interface:** Compliant with USB 2.0 high-speed bus protocol
- **Supported USB Mode:** Bulk Only Transfer (BOT)
- **USB Interface Transfer Rate:** 480 Mbits/s (max)
- **Capacity:**
  - ◆ 1 GBytes to 32 GBytes
- **Data Rates:**
  - ◆ **Read, Sustained:** up to 34 MBytes/second
  - ◆ **Write, Sustained:** up to 29 MBytes/second
- **Operating Temperatures:**
  - ◆ **Commercial:** 0 °C to 70 °C
- **Power Requirements:**
  - ◆ **Active (Typical):** 110 mA
  - ◆ **Idle (Typical):** 50 mA

---

### 1.3 Unique Features

- Whole-drive global wear leveling
- Advanced Error Detection/Correction circuitry for superior data reliability
- Shock and vibration resistant
- Low power dissipation
- USB-class definition for boot-ability support
- Field-upgradeable firmware via USB bus
- Small Form Factor

## 1.4 Operational Characteristics

All listed values are typical unless otherwise stated.

### 1.4.1 Performance

**Table 1:** Performance Characteristics

Item	Estimated Performance
Sustained Sequential Read (Maximum)	34 MBytes/second
Sustained Sequential Write (Maximum)	29 MBytes/second
Host Interface Transfer Rate (Maximum)	480 Mbits/second

### 1.4.2 Reliability

**Table 2:** Reliability Characteristics

Item	Value
Data Retention @ 25 °C	10 years > 90% life remaining 1 years < 10% life remaining
Endurance*	3 TBW (1GB); 6 TBW (2GB); 12 TBW (4GB); 24 TBW (8GB); 80 TBW (16GB); 160 TBW (32GB)
Error Correction/Error Detection	Multi-bit correction supported for programmed NAND data.

\* Endurance is directly related to the User specific workload.

### 1.4.3 Power Requirements

**Table 3:** Power Requirements (5V)

Parameter	Value (Typ)	Value (Max)	Unit
V <sub>IN</sub>	5.0	5.5	V
Read	100	120	mA
Write	100	120	mA
Idle	50	60	mA

#### 1.4.4 Environmental Conditions

**Table 4:** Environmental Conditions and Testing

Parameter	Value
Shock/Acceleration – Operating Half-Sine	70 in/sec, 3 shocks along each axis, X, Y, Z, in each direction
Vibration – Operating	0.9 g rms 10-500 Hz, 30 minutes per side (total of 6 sides)
Vibration – Non-Operating, Random	13.6 g rms 10-500 Hz, 30 minutes per side (total of 6 sides)
Operating Temperature – Commercial	0 °C to 70 °C
Storage Temperature	-40 °C to 85 °C

#### 1.4.5 Physical Characteristics

**Table 5:** Physical Characteristics

Parameter	Value
Length	45.97 mm [1.81 in]
Width	15.49 mm [0.61 in]
Height (Mounted)	6.0 mm [0.24 in]



## 2.0 PRODUCT DESCRIPTION

The SMART USB Memory Keys contains an integrated USB 2.0 high-speed interface and a NAND flash controller with corresponding flash memory devices. This system architecture logically and efficiently translates standard USB reduced block commands (RBCs) into flash memory accesses. Parallel access to the flash memory allows overlapped, multi-block access to complete data transfer requests rapidly.

### 2.1 Functional Block Diagram

**Figure 1:** USB Memory Key Module Block Diagram

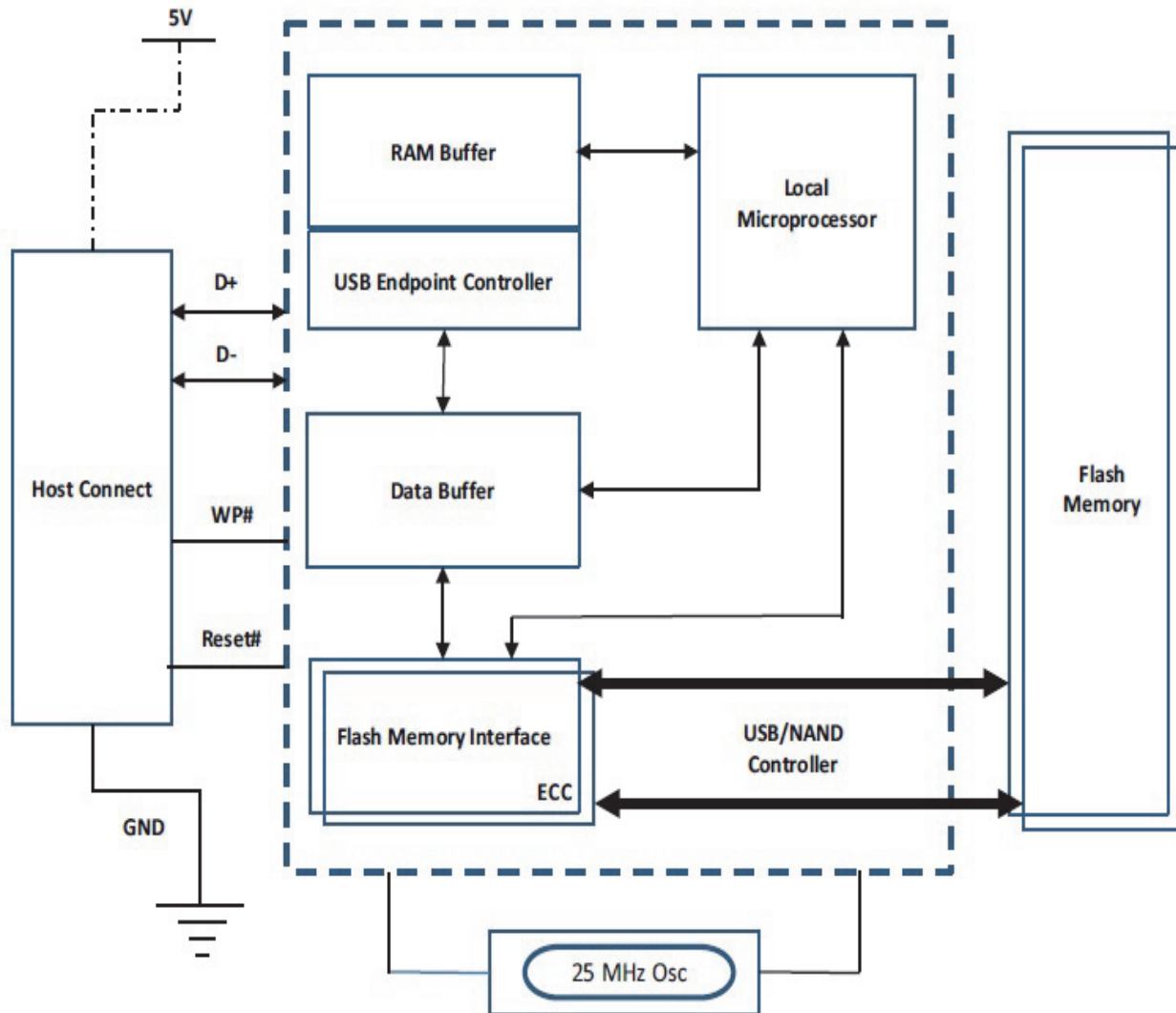

---

## 2.2 Mean Time Between Failures (MTBF)

The MTBF statistic for the USB Memory Key was calculated based on the RDF2000 UTE C80-810 Telecom Standard at 25 °C (drive temperature).

**Table 6:** MTBF Values

Drive Capacity	# of Chips	MTBF (Hours)
All	1	4,645,509

### 3.0 MECHANICAL SPECIFICATION

Figure 2: USB Memory Key Dimensions (in mm [inches])

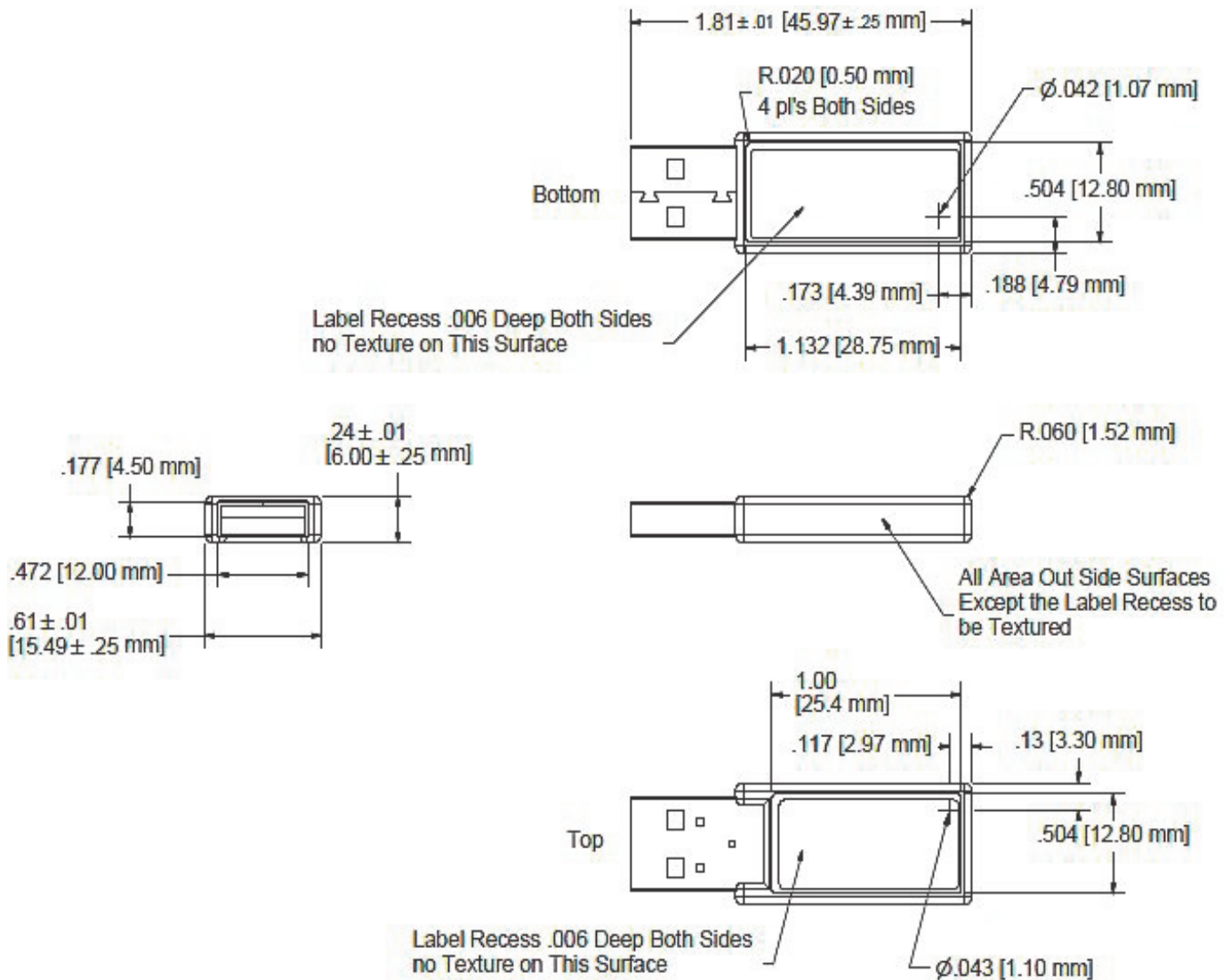

## 4.0 ELECTRICAL SPECIFICATION

### 4.1 Electrical Interface

The USB Memory Key is compliant with the USB 2.0 standard.

#### 4.1.1 Mating Connector

The USB Memory Key uses a 4-pin, type A USB standard connector. It can use any female connector, such as AMCO P/N 211-100400-051.

#### 4.1.2 Pinout Descriptions

Table 7: Pinout Descriptions (4-Pin)

Pin	Signal Name	Signal Description
1	5V	5 Volts
2	DM	Data -
3	DP	Data +
4	GND	Ground

### 4.2 Absolute Maximum Ratings

Table 8: Voltage and Storage Temperature \*

Symbol	Parameter	Ratings (Min)	Ratings (Max)	Unit
$V_{IN5}$	5 V Supply Voltage	4.5	5.5	V
$I_{ACTIVE5}$	Active Current (5 V)	80	120	mA
$T_A$	Operating Temperature	0	70	°C
$T_{STG}$	Storage Temperature	-40	85	°C

\* Stress beyond the Absolute Maximum Rating conditions may result in permanent damage to the device. These are stress ratings only and functional operation should be restricted to those indicated in the operational sections of this specification. Exposure to conditions beyond recommended, up to and including the Absolute Maximum Rating conditions, for extended periods may affect device reliability.

### 4.3 Recommended Operating Conditions

Table 9: Recommended Operating Conditions

Symbol	Parameter	Ratings	Unit
$V_{IN5}$	5 V Supply Voltage	$5 \pm 10\%$	V
$T_A$	Operating Temperature – Commercial	0 °C to 70 °C	°C

## 4.4 DC Characteristics

**Table 10:** DC Characteristics

Symbol	Parameter	Typical	Max	Unit	Condition
$I_{RD5}$	Active Read Current	100	120	mA	$V_{IN} = 5\text{ V}$
$I_{WR5}$	Active Write Current	100	120	mA	$V_{IN} = 5\text{ V}$
$I_{IDLE5}$	Idle Current	50	60	mA	$V_{IN} = 5\text{ V}$

## 5.0 USB COMMANDS

The standard class interface specification is currently implemented in the USB Memory Key. The SMART USB device does not support Interrupt or Isynchronous transport protocols. For the purpose of data integrity, only Bulk and Control Transport modes are implemented.

### 5.1 Standard Descriptor

The SMART Modular USB device supports the following standard USB descriptors:

- **Device Descriptor:** Contains one descriptor.
- **Configuration:** Contains one default configuration descriptor, which supports the Bulk-Only Data Interface.
- **Interface:** Supports the Bulk-Only Data Interface.
- **Endpoint:** Supports the following endpoints:
  - ◆ Control
  - ◆ Bulk-In
  - ◆ Bulk-Out

<b>NOTE:</b>	The host uses the first reported Bulk-In and Bulk-Out endpoints for the selected interface.
--------------	---

- **String:** Provides a string field with the following information:
  - ◆ SMART Vendor ID = 0E39
  - ◆ USB Key Product ID = 2F00
  - ◆ Product Inquiry = USB
  - ◆ Device ID = See the decoder in [Table 16](#)
  - ◆ Unique Serial Number

## 5.2 Device Descriptor

The USB device has one device descriptor which is described below.

**Table 11:** Device Descriptor

Offset	Field	Size	Value	Description
0	bLength	Byte	12h	Size of this descriptor, in bytes.
1	bDescriptorType	Byte	01h	Device descriptor type.
2	bcdUSB	Word	0200h	USB specification release number in binary-code decimal.
4	bDeviceClass	Byte	00h	Class is specified in the interface descriptor.
5	bDeviceSubClass	Byte	00h	Subclass is specified in the interface descriptor.
6	bDeviceProtocol	Byte	00h	The 00h protocol is specified in the interface descriptor.
7	bMaxPacketSize0	Byte	40h	Maximum packet size for endpoint zero. Valid values are 8, 16, 32, or 64 (08h, 10h, 20h, or 40h).
8	idVendor	Word	0E39h	Vendor ID assigned by the USB-IF.
10	idProduct	Word	2F00h	SMART Modular product ID.
12	bcdDevice	Word	Varies	Firmware encoding
14	iManufactures	Byte	01h	Index of string descriptor describing the manufacturer.
15	iProduct	Byte	02h	Index of string descriptor describing the product.
16	iSerialNumber	Byte	03h	Index of string descriptor describing the serial number of the device.
17	bNumConfiguration	Byte	01h	Number of possible configurations.

### 5.3 Configuration Descriptor

The USB device has one default configuration descriptor which supports the Bulk-Only Data Interface. The configuration descriptor describes information about a specific device configuration. It contains a **bConfiguration Value** field with a value that, when used as a parameter to the setConfiguration() request, causes the device to select the configuration.

**Table 12:** Configuration Descriptor

Offset	Field	Size	Value	Description										
0	bLength	Byte	09h	Size of the descriptor, in bytes.										
1	bDescriptorType	Byte	02h	Configuration descriptor type.										
2	wTotalLength	Word	0020h	Total length of data returned for this configuration. This includes combined length of all descriptors (configuration, interface, endpoint, and class- or vendor-specific).										
4	bNumInterfaces	Byte	01h	Number of interfaces supported by this configuration. The device only supports the Bulk-Only Data interface.										
5	bConfigurationValue	Byte	01h	Value to use as an argument in the setConfiguration() request to select this configuration.										
6	iConfiguration	Byte	00h	Index of the string descriptor describing this configuration.										
7	bmAttributes	Byte	80h	Configuration characteristics. Possible values are: <table border="1" data-bbox="906 1108 1185 1260"> <thead> <tr> <th>Bit</th> <th>Description</th> </tr> </thead> <tbody> <tr> <td>7</td> <td>Reserved (set to 1)</td> </tr> <tr> <td>6</td> <td>Self-Powered</td> </tr> <tr> <td>5</td> <td>Remote</td> </tr> <tr> <td>4..0</td> <td>Reserved (reset to zero) bit</td> </tr> </tbody> </table> 7 is reserved and must be set to one. For a full description of the bmAttributes bitmap, refer to the USB 2.0 Standard.	Bit	Description	7	Reserved (set to 1)	6	Self-Powered	5	Remote	4..0	Reserved (reset to zero) bit
Bit	Description													
7	Reserved (set to 1)													
6	Self-Powered													
5	Remote													
4..0	Reserved (reset to zero) bit													
8	maxPower	Byte	32h	Maximum power consumption of the USB device from the bus when the device is fully operational, in 2mA units (for example, 50=100mA).										

## 5.4 Bulk-Only Data Interface Descriptor

The Bulk-Only Data Interface descriptor describes a specific interface within a configuration. A configuration provides one or more interfaces, each with zero or more endpoint descriptors that describe a unique set of endpoints within the configuration.

**Table 13:** Bulk-Only Data Interface Descriptor

Offset	Field	Size	Value	Description
0	bLength	Byte	09h	Size of the descriptor, in bytes.
1	bDescriptorType	Byte	04h	Interface descriptor type.
2	bInterfaceNumber	Byte	00h	Interface number. This is a zero-based value identifying the index in the array of concurrent interfaces supported by this configuration.
3	bAlternateSetting	Byte	00h	Value used to select alternate setting for the interface identified in the <b>bInterfaceNumber</b> field.
4	bNumEndpoints	Byte	02h	Number of endpoints used by this interface, excluding endpoint zero.
5	bInterfaceClass	Byte	08h	Mass storage class.
6	bInterfaceSubClass	Byte	06h	Subclass code assigned by the USB-IF which indicates the industry-standard command block definition to use. The 06h value indicates the USB is using the SCSI transparent command set based on the USB Mass Storage Overview Standard.
7	bInterfacedProtocol	Byte	50h	Bulk-Only Transport.
8	iInterface	Byte	00h	Index to the string descriptor describing this interface.



## 5.5 Endpoint Descriptors

The SMART Modular USB device supports three endpoints: Control, Bulk-In and Bulk-Out. The Control endpoint defaults to 0 and does not require a descriptor.

### 5.5.1 Bulk-In Endpoint Descriptor

**Table 14:** Bulk-In Endpoint Descriptor

Offset	Field	Size	Value	Description								
0	bLength	Byte	07h	Size of the descriptor, in bytes.								
1	bDescriptorType	Byte	05h	Endpoints descriptor type.								
2	bEndpointAddress	Byte	81h	Address of this endpoint on the USB device. The address is encoded as follows:  <table border="0"> <tr> <td><b>Bit</b></td> <td><b>Description</b></td> </tr> <tr> <td>7</td> <td>1 = In</td> </tr> <tr> <td>6..4</td> <td>Reserved (set to 0)</td> </tr> <tr> <td>3..0</td> <td>The endpoint number</td> </tr> </table>	<b>Bit</b>	<b>Description</b>	7	1 = In	6..4	Reserved (set to 0)	3..0	The endpoint number
<b>Bit</b>	<b>Description</b>											
7	1 = In											
6..4	Reserved (set to 0)											
3..0	The endpoint number											
3	bAttributes	Byte	02h	This is a bulk endpoint.								
4	wMaxPacketSize	Word	0200h	Maximum packet size.								
6	bInterval	Byte	00h	Does not apply to bulk endpoints.								

### 5.5.2 Bulk-Out Endpoint Descriptor

**Table 15:** Bulk-Out Endpoint Descriptor

Offset	Field	Size	Value	Description								
0	bLength	Byte	07h	Size of the descriptor, in bytes.								
1	bDescriptorType	Byte	05h	Endpoints descriptor type.								
2	bEndpointAddress	Byte	02h	Address of this endpoint on the USB device. The address is encoded as follows:  <table border="0"> <tr> <td><b>Bit</b></td> <td><b>Description</b></td> </tr> <tr> <td>7</td> <td>0 = Out</td> </tr> <tr> <td>6..4</td> <td>Reserved (set to 0)</td> </tr> <tr> <td>3..0</td> <td>The endpoint number</td> </tr> </table>	<b>Bit</b>	<b>Description</b>	7	0 = Out	6..4	Reserved (set to 0)	3..0	The endpoint number
<b>Bit</b>	<b>Description</b>											
7	0 = Out											
6..4	Reserved (set to 0)											
3..0	The endpoint number											
3	bAttributes	Byte	02h	This is a bulk endpoint.								
4	wMaxPacketSize	Word	0200h	Maximum packet size.								
6	bInterval	Byte	00h	Does not apply to bulk endpoints.								

## 6.0 REDUCED BLOCK COMMANDS (RBC) DESCRIPTORS

The Reduced Block Commands (RBC) - simplified versions of SCSI Block Commands - 2(SBC-2), along with the required SCSI Primary Commands - 2(SPC-2), fully specify the complete command set for RBC logical block devices.

**Table 16:** Reduced Block Command Descriptor Descriptions

Command	OpCode	Command Support	SMART Supported	Revised Spec
FORMAT UNIT	04h	O	No	RBC
INQUIRY	12h	M	Yes	SPC-2
MODE SELECT (6)	15h	M	Yes	SPC-2
MODE SENSE (6)	1Ah	M	Yes	SPC-2
PERSISTENT RESERVE IN	5Eh	O	No	SPC-2
PERSISTENT RESERVE OUT	5Fh	O	No	SPC-2
PREVENT.ALLOW MEDIUM REMOVAL	1Eh	M	Yes	SPC-2
READ (10)	28h	M	Yes	RBC
READ CAPACITY	25h	M	Yes	RBC
RELEASE (6)	17h	O	No	SPC-2
REQUEST SENSE	03h	O	Yes	SPC-2
RESERVE (6)	16h	O	No	SPC-2
START STOP UNIT	1Bh	M	Yes	RBC
SYNCHRONIZE CACHE	35h	O	No	RBC
TEST UNIT READY	00h	M	Yes	SPC-2
VERIFY (10)	2Fh	M	Yes	RBC
WRITE (10)	2Ah	M	Yes	RBC
WRITE BUFFER	3Bh	O	Yes	SPC-2
MODE SENSE (10)	5Ah	B	Yes	USB-Boot

**NOTES:**

- The CONTROL byte (last byte of CDB) is set to zero.
- When a reduced block command is not supported, the USB drive returns STALL and waits for the host to send a Clear Feature command to reset the drive.
- Command Support Key:
  - M = Mandatory
  - N/A = Not applicable
  - O = Optional
  - B = Bootability

## 7.0 PART NUMBERS

### 7.1 Part Numbering Information

**Table 17:** Device Part Numbering Information

SMART Part Number	Capacity	Chip Density	Page Size	Chip Qty	Read Speed (MB/s)	Write Speed (MB/s)	Random Access Time (msec)	Typ. Write Current (mA)
SH9MK1GQ9	1 GB	1 Gb	4K	1	14	19	0.9	85
SH9MK2GQA	2 GB	16 Gb	4K	1	15	19	0.8	90
SH9MK4GQB	4 GB	32 Gb	8K	1	26	33	0.6	100
SH9MK8GQC	8 GB	64 Gb	8K	1	27	33	0.7	110
SH9MK8EQC	8 GB	64 Gb	8K	1	27	33	0.7	110
SH9MK16GQD	16 GB	128 Gb	8K	1	30	33	0.8	122
SH9MK32GQE	32 GB	256 Gb	8K	1	27	34	0.8	140

**Table 18:** Part Capacity Information

SMART Part Number	Capacity	Addressable LBAs	Unformatted Capacity
SH9MK1GQ9	1 GB	1,957,888	1,002,438,656
SH9MK2GQA	2 GB	3,909,632	2,001,731,584
SH9MK4GQB	4 GB	7,745,536	3,965,714,432
SH9MK8GQC	8 GB	15,466,496	7,918,845,952
SH9MK8EQC	8 GB	15,646,720	8,011,120,640
SH9MK16GQD	16 GB	30,941,184	15,841,886,208
SH9MK32GQE	32 GB	61,751,296	31,616,663,552

## 7.2 Part Number Decoder

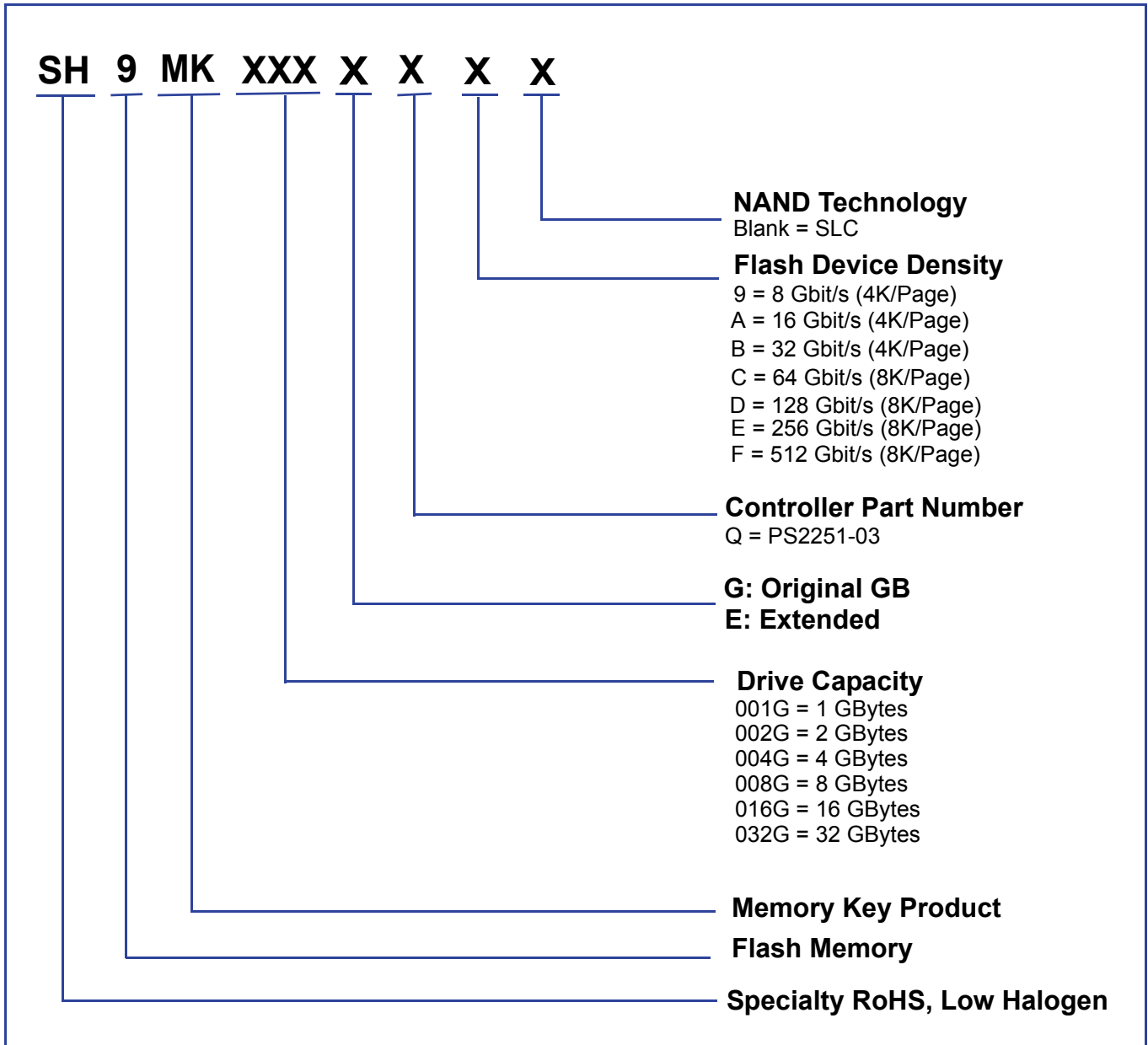

## 8.0 PRODUCT LABEL

**Figure 3:** Sample USB Memory Key (SH9MK16GQD) Product Labeling (front and back)

**16 GBytes**

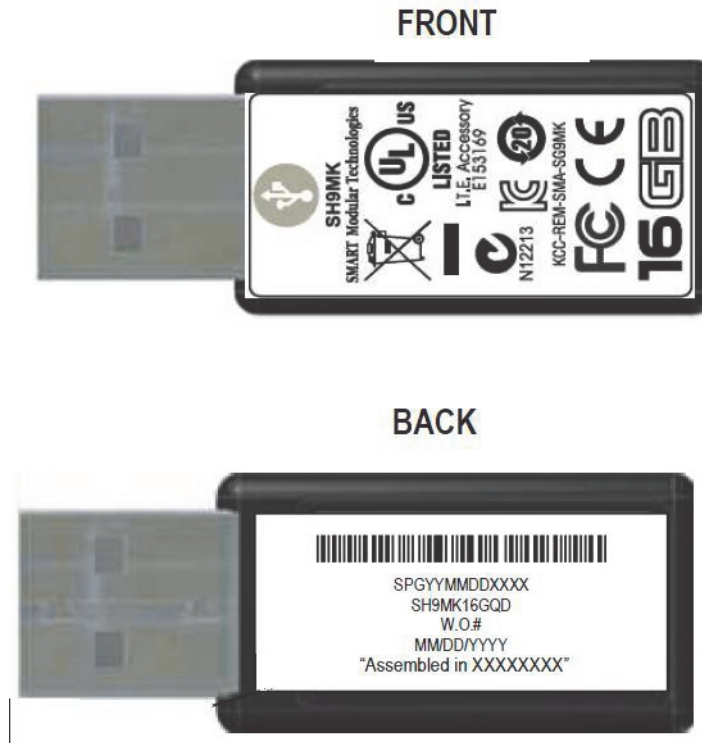

## Declaration of Conformity



Responsible Party Name: SMART Modular Technologies, Inc.  
Address: 39870 Eureka Drive  
Newark, CA 94560-4809, USA  
Phone: +1-510-623-1231

hereby declares that the products:

**PN: SH9MKXXGQXX**

to which this declaration relates are in conformity with the following Directives and other normative documents:

### RoHS Directive 2011/65/EU

Restriction of the use of certain hazardous substances in electrical and electronic equipment

- **EN 50581:2012**

Technical documentation for the assessment of electrical and electronic products with respect to the restriction of hazardous substances

Name: Jeffrey Milano  
Title: Director, Worldwide Quality  
Date: August 2015

**Representative in the European Union (for regulatory topics only):**

Mr. Graham Kyle  
SMART Modular Technologies (Europe) Ltd.  
312 Nasmyth Building, Nasmyth Avenue  
Scottish Enterprise Technology Park  
East Kilbride, Scotland, G75 0QR

**Corporate Headquarters:** 39870 Eureka Dr., Newark, CA 94560, USA ♦ Tel:(510) 623-1231 ♦ Fax:(510) 623-1434 ♦ E-mail: info@smartm.com  
**Flash Design Center:** 2 Highwood Dr, Suite 101, Tewksbury, MA 01876 USA ♦ Tel:(978) 805-2100 ♦ Fax:(978) 805-2357  
**Asia:** Plot 18, Lrg Jelawat 4, Kawasan Perindustrian Seberang Jaya 13700, Prai, Penang, Malaysia ♦ Tel:+604-3992909 ♦ Fax:+604-3992903

---

**Disclaimer:**

No part of this document may be copied or reproduced in any form or by any means, or transferred to any third party, without the prior written consent of an authorized representative of SMART Modular Technologies, Inc. ("SMART"). The information in this document is subject to change without notice. SMART assumes no responsibility for any errors or omissions that may appear in this document, and disclaims responsibility for any consequences resulting from the use of the information set forth herein. SMART makes no commitments to update or to keep current information contained in this document. The products listed in this document are not suitable for use in applications such as, but not limited to, aircraft control systems, aerospace equipment, submarine cables, nuclear reactor control systems and life support systems. Moreover, SMART does not recommend or approve the use of any of its products in life support devices or systems or in any application where failure could result in injury or death. If a customer wishes to use SMART products in applications not intended by SMART, said customer must contact an authorized SMART representative to determine SMART's willingness to support a given application. The information set forth in this document does not convey any license under the copyrights, patent rights, trademarks or other intellectual property rights claimed and owned by SMART. The information set forth in this document is considered to be "Proprietary" and "Confidential" property owned by SMART.

ALL PRODUCTS SOLD BY SMART ARE COVERED BY THE PROVISIONS APPEARING IN SMART'S TERMS AND CONDITIONS OF SALE ONLY, INCLUDING THE LIMITATIONS OF LIABILITY, WARRANTY AND INFRINGEMENT PROVISIONS. SMART MAKES NO WARRANTIES OF ANY KIND, EXPRESS, STATUTORY, IMPLIED OR OTHERWISE, REGARDING INFORMATION SET FORTH HEREIN OR REGARDING THE FREEDOM OF THE DESCRIBED PRODUCTS FROM INTELLECTUAL PROPERTY INFRINGEMENT, AND EXPRESSLY DISCLAIMS ANY SUCH WARRANTIES INCLUDING WITHOUT LIMITATION ANY EXPRESS, STATUTORY OR IMPLIED WARRANTIES OF MERCHANTABILITY OR FITNESS FOR A PARTICULAR PURPOSE.

©August 2015 SMART Modular Technologies, Inc. All rights reserved.

# Mouser Electronics

Authorized Distributor

Click to View Pricing, Inventory, Delivery & Lifecycle Information:

[SMART Modular Technologies:](#)

[SH9MK1GQ9](#) [SH9MK2GQA](#) [SH9MK4GQB](#) [SH9MK8GQC](#) [SH9MK16GQD](#) [SH9MK32GQE](#) [SH9MK16GQDU](#)