

# SLG59M1713V

## An Ultra-small, 4 mΩ, 2 A Integrated Power Switch with Multiple Protection Features

### General Description

Operating from a 2.5 V to 5.5 V power supply and fully specified over the -40 °C to 85 °C temperature range, the SLG59M1713V is a high-performance 4 mΩ, 2 A single-channel nFET integrated power switch with adjustable inrush current control which is achieved by adjusting the  $V_{OUT}$  slew rate with an external capacitor. Using a proprietary MOSFET design, the SLG59M1713V achieves a stable 4 mΩ  $R_{DS(ON)}$  across a wide input/supply voltage range. Incorporating two-stage current protection as well as thermal protection, the SLG59M1713V is designed for all 0.8 V to 5.5V power rail applications. Using Dialog's proprietary CuFET™ technology for high-current operation, the SLG59M1713V is packaged in a space-efficient, low thermal resistance, RoHS-compliant 1.6 mm x 2.5 mm STQFN package

### Features

- Low Typical  $R_{DS(ON)}$  nFET: 4 mΩ
- Maximum Continuous Switch Current: Up to 2 A
- Supply Voltage:  $2.5\text{ V} \leq V_{DD} \leq 5.5\text{ V}$
- Wide Input Voltage Range:  $0.8\text{ V} \leq V_{IN} \leq V_{DD}$
- Capacitor-adjustable Start-up and Inrush Current Control
- Two-stage Overcurrent Protection:
  - Fixed threshold, 4 A Active Current Limit
  - Fixed 0.5 A Short-circuit Current Limit
- Internal  $V_{OUT}$  Discharge
- Operating Temperature: -40 °C to 85 °C
- Low  $\theta_{JA}$ , 16-pin 1.6 mm x 2.5 mm STQFN Packaging
  - Pb-Free / Halogen-Free / RoHS compliant

### Pin Configuration

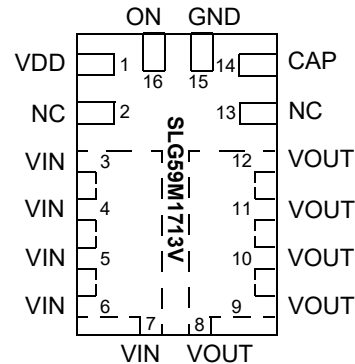

**16-pin FC-STQFN  
(Top View)**

### Applications

- Notebook Power Rail Switching
- Tablet Power Rail Switching
- Smartphone Power Rail Switching

### Block Diagram

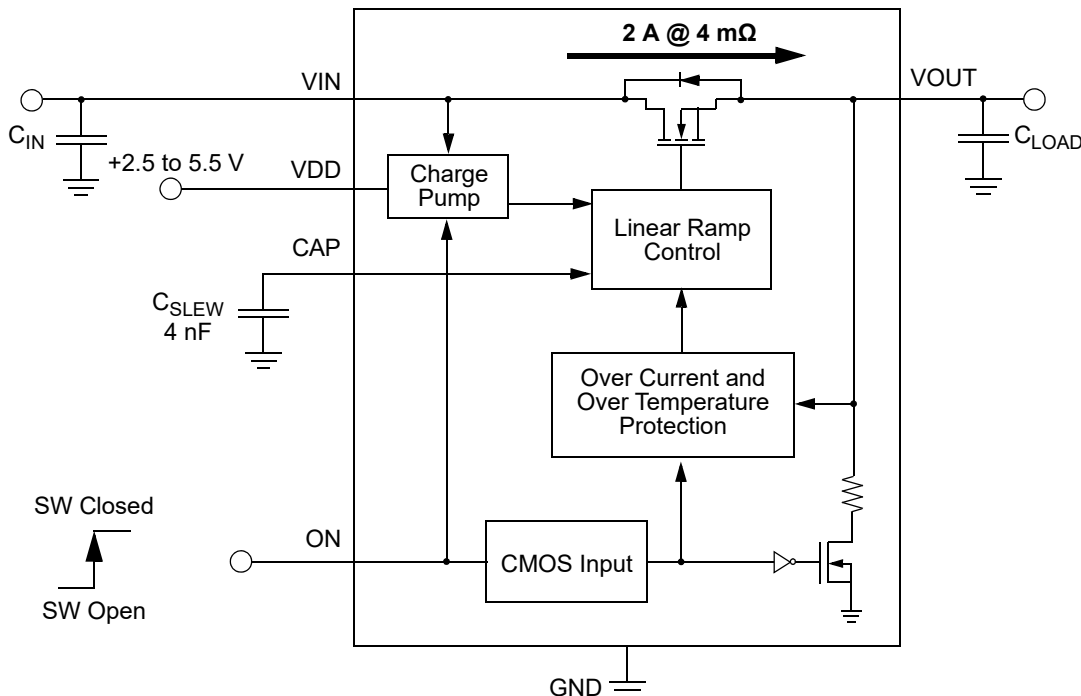

## An Ultra-small, 4 mΩ, 2 A Integrated Power Switch with Multiple Protection Features

### Pin Description

Pin #	Pin Name	Type	Pin Description
1	VDD	Power	With an internal 1.9 V $V_{DD(UVLO)}$ threshold, VDD supplies the power for the operation of the power switch and internal control circuitry where its range is $2.5\text{ V} \leq V_{DD} \leq 5.5\text{ V}$ . Bypass the VDD pin to GND with a 0.1 $\mu\text{F}$ (or larger) capacitor
2	NC	NC	No Connect
3-7	VIN	MOSFET	Drain terminal of Power MOSFET (Pins 3-7 fused together). Connect a 10 $\mu\text{F}$ (or larger) low ESR capacitor from this pin to GND. Capacitors used at VIN should be rated at 10 V or higher.
8-12	VOUT	MOSFET	Source terminal of Power MOSFET (Pins 8-12 fused together). Connect a low ESR capacitor (up to 500 $\mu\text{F}$ ) from this pin to GND. Capacitors used at VOUT should be rated at 10 V or higher.
13	NC	NC	No Connect
14	CAP	Input	A low-ESR, stable dielectric, ceramic surface-mount capacitor connected from CAP pin to GND sets the $V_{OUT}$ slew rate and overall turn-on time of the SLG59M1713V. For best performance, the range for $C_{SLEW}$ values are $2\text{ nF} \leq C_{SLEW} \leq 22\text{ nF}$ . Capacitors used at the CAP pin should be rated at 10 V or higher.
15	GND	GND	Ground
16	ON	Input	A low-to-high transition on this pin closes the power switch. ON is an asserted-HIGH, level-sensitive CMOS input with $ON_{V_{IL}} < 0.3\text{ V}$ and $ON_{V_{IH}} > 0.85\text{ V}$ . While there is an internal pull down circuit to ground ( $\sim 4\text{ M}\Omega$ ), connect this pin to the output of a general-purpose output (GPO) from a microcontroller or other application processor.

### Ordering Information

Part Number	Type	Production Flow
SLG59M1713V	STQFN 16L	Industrial, -40 °C to 85 °C
SLG59M1713VTR	STQFN 16L (Tape and Reel)	Industrial, -40 °C to 85 °C

## An Ultra-small, 4 mΩ, 2 A Integrated Power Switch with Multiple Protection Features

### Absolute Maximum Ratings

Parameter	Description	Conditions	Min.	Typ.	Max.	Unit
V <sub>DD</sub>	Power Supply Pin Voltage to GND		--	--	6	V
V <sub>IN</sub> to GND	Power Switch Input Voltage to GND		-0.3	--	6	V
V <sub>OUT</sub> to GND	Power Switch Output Voltage to GND		-0.3	--	V <sub>IN</sub>	V
ON, CAP to GND	ON and CAP Pin Voltages to GND		-0.3	--	6	V
T <sub>S</sub>	Storage Temperature		-65	--	150	°C
ESD <sub>HBM</sub>	ESD Protection	Human Body Model	2000	--	--	V
ESD <sub>CDM</sub>	ESD Protection	Charged Device Model	500	--	--	V
MSL	Moisture Sensitivity Level		1			
θ <sub>JA</sub>	Package Thermal Resistance, Junction-to-Ambient	1.6 x 2.5 mm 16L STQFN; Determined using 1 in <sup>2</sup> , 1.2 oz. copper pads under each VIN and VOUT on FR4 pcb material	--	35	--	°C/W
W <sub>DIS</sub>	Package Power Dissipation		--	--	1.2	W
MOSFET I <sub>DS</sub> CONT	Continuous Current from VIN to VOUT		--	--	2	A
MOSFET I <sub>DS</sub> PK	Peak Current from VIN to VOUT	Maximum pulsed switch current, pulse width < 1 ms, 1% duty cycle	--	--	3	A

Note: Stresses greater than those listed under "Absolute Maximum Ratings" may cause permanent damage to the device. This is a stress rating only and functional operation of the device at these or any other conditions above those indicated in the operational sections of this specification is not implied. Exposure to absolute maximum rating conditions for extended periods may affect reliability.

### Electrical Characteristics

T<sub>A</sub> = -40 °C to 85 °C (unless otherwise stated). Typical values are at T<sub>A</sub> = 25 °C

Parameter	Description	Conditions	Min.	Typ.	Max.	Unit
V <sub>DD</sub>	Power Supply Voltage		2.5	--	5.5	V
V <sub>DD(UVLO)</sub>	V <sub>DD</sub> Undervoltage Lockout Threshold	V <sub>DD</sub> ↑	1.6	1.9	2.2	V
		V <sub>DD</sub> ↓	1.5	1.8	2.2	V
I <sub>DD</sub>	Power Supply Current, when OFF	V <sub>DD</sub> = V <sub>IN</sub> = 5.5 V; ON = 0 V	--	1	2	μA
	Power Supply Current, when ON	V <sub>DD</sub> = V <sub>IN</sub> = ON = 5.5 V; No Load	--	120	170	μA
RDS <sub>ON</sub>	ON Resistance	V <sub>DD</sub> = V <sub>IN</sub> = 5 V; T <sub>A</sub> = 25 °C; I <sub>DS</sub> = 100 mA	--	4	5.5	mΩ
		V <sub>DD</sub> = V <sub>IN</sub> = 5 V; T <sub>A</sub> = 85 °C; I <sub>DS</sub> = 100 mA	--	5	6.8	mΩ
MOSFET I <sub>DS</sub>	Current from VIN to VOUT	Continuous	--	--	2	A
I <sub>FET_OFF</sub>	MOSFET OFF Leakage Current	V <sub>DD</sub> = V <sub>IN</sub> = 5.5 V; V <sub>OUT</sub> = 0 V; ON = 0 V	--	--	2	μA
V <sub>IN</sub>	Drain Voltage		0.8	--	V <sub>DD</sub>	V
I <sub>LIMIT</sub>	Active Current Limit, I <sub>ACL</sub>	V <sub>OUT</sub> > 0.3 V	3	4	5	A
	Short-circuit Current Limit, I <sub>SCL</sub>	V <sub>OUT</sub> < 0.3 V	--	0.5	--	A

An Ultra-small, 4 mΩ, 2 A Integrated Power Switch with Multiple Protection Features

**Electrical Characteristics (continued)**

T<sub>A</sub> = -40 °C to 85 °C (unless otherwise stated). Typical values are at T<sub>A</sub> = 25 °C

Parameter	Description	Conditions	Min.	Typ.	Max.	Unit
T <sub>ON_Delay</sub>	ON Delay Time	50% ON to V <sub>OUT</sub> Ramp Start; V <sub>DD</sub> = V <sub>IN</sub> = 5 V; C <sub>SLEW</sub> = 4 nF; R <sub>LOAD</sub> = 20 Ω, C <sub>LOAD</sub> = 10 μF	--	200	--	μs
V <sub>OUT(SR)</sub>	V <sub>OUT</sub> Slew Rate	10% V <sub>OUT</sub> to 90% V <sub>OUT</sub> ↑	Set by External C <sub>SLEW</sub> <sup>1</sup>			V/ms
		Example: C <sub>SLEW</sub> = 4 nF; V <sub>DD</sub> = V <sub>IN</sub> = 5 V; R <sub>LOAD</sub> = 20 Ω, C <sub>LOAD</sub> = 10 μF	2.5	2.9	3.5	V/ms
T <sub>Total_ON</sub>	Total Turn On Time	50% ON to 90% V <sub>OUT</sub> ↑	Set by External C <sub>SLEW</sub> <sup>1</sup>			ms
		Example: C <sub>SLEW</sub> = 4 nF; V <sub>DD</sub> = V <sub>IN</sub> = 5 V; R <sub>LOAD</sub> = 20 Ω, C <sub>LOAD</sub> = 10 μF	1.4	1.7	2	ms
T <sub>OFF_Delay</sub>	OFF Delay Time	50% ON to V <sub>OUT</sub> Fall Start; V <sub>DD</sub> = V <sub>IN</sub> = 5 V; R <sub>LOAD</sub> = 20 Ω, no C <sub>LOAD</sub>	--	8	15	μs
C <sub>LOAD</sub>	Output Load Capacitance	C <sub>LOAD</sub> connected from V <sub>OUT</sub> to GND	--	--	500	μF
R <sub>DISCHRG</sub>	Output Discharge Resistance	V <sub>IN</sub> = V <sub>DD</sub> = 5 V; ON = 0 V; V <sub>OUT</sub> = 0.4 V	170	200	250	Ω
ON_V <sub>IH</sub>	High Input Voltage on ON pin		0.85	--	V <sub>DD</sub>	V
ON_V <sub>IL</sub>	Low Input Voltage on ON pin		-0.3	0	0.3	V
I <sub>ON(LKG)</sub>	ON Pin Leakage Current	ON = ON_V <sub>IH</sub> or ON = GND	--	1.5	--	μA
THERM <sub>ON</sub>	Thermal shutoff turn-on temperature		--	125	--	°C
THERM <sub>OFF</sub>	Thermal shutoff turn-off temperature		--	100	--	°C

Notes:

1. Refer to typical Timing Parameter vs. C<sub>SLEW</sub> performance charts for additional information when available.

**T<sub>Total\_ON</sub>, T<sub>ON\_Delay</sub> and Rise Time Measurement**

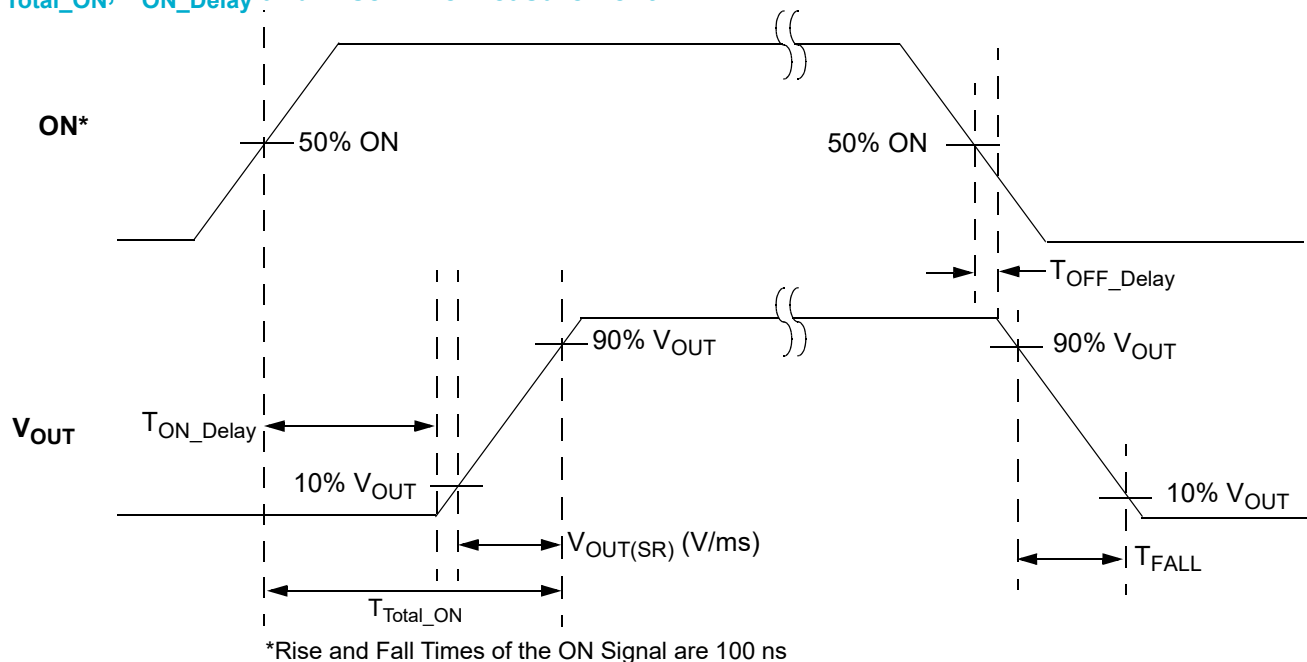

An Ultra-small, 4 mΩ, 2 A Integrated Power Switch with Multiple Protection Features

Typical Performance Characteristics

RDS<sub>ON</sub> vs. V<sub>DD</sub> and Temperature

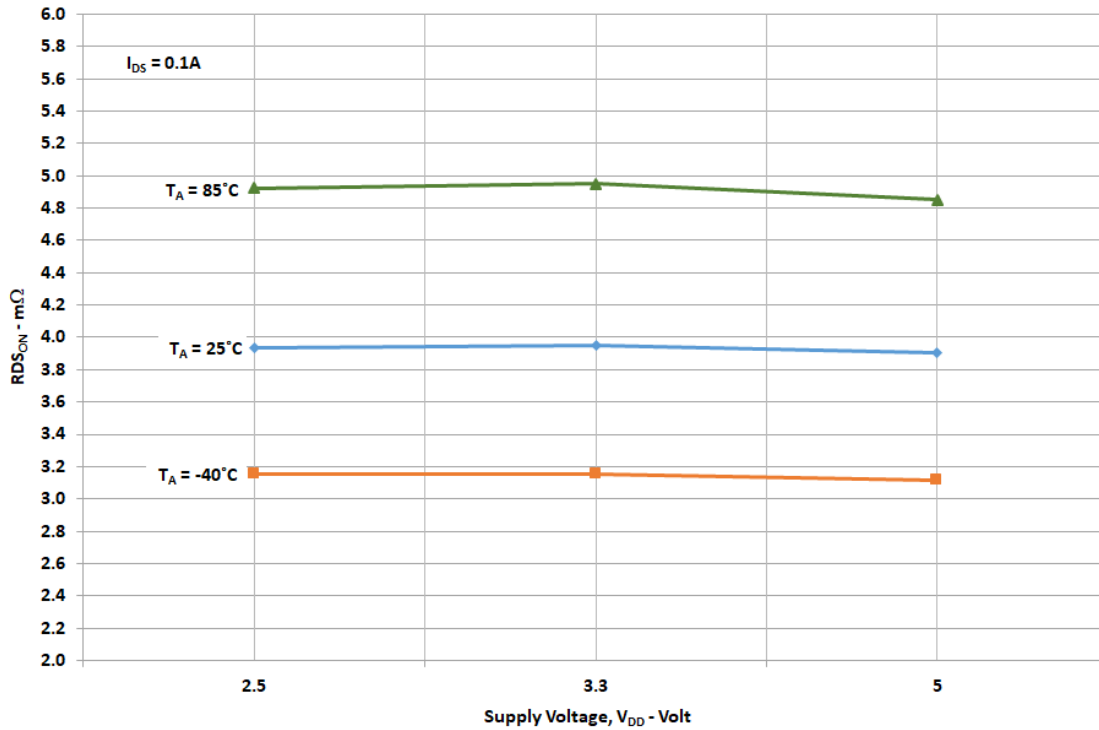

RDS<sub>ON</sub> vs. V<sub>IN</sub> and V<sub>DD</sub>

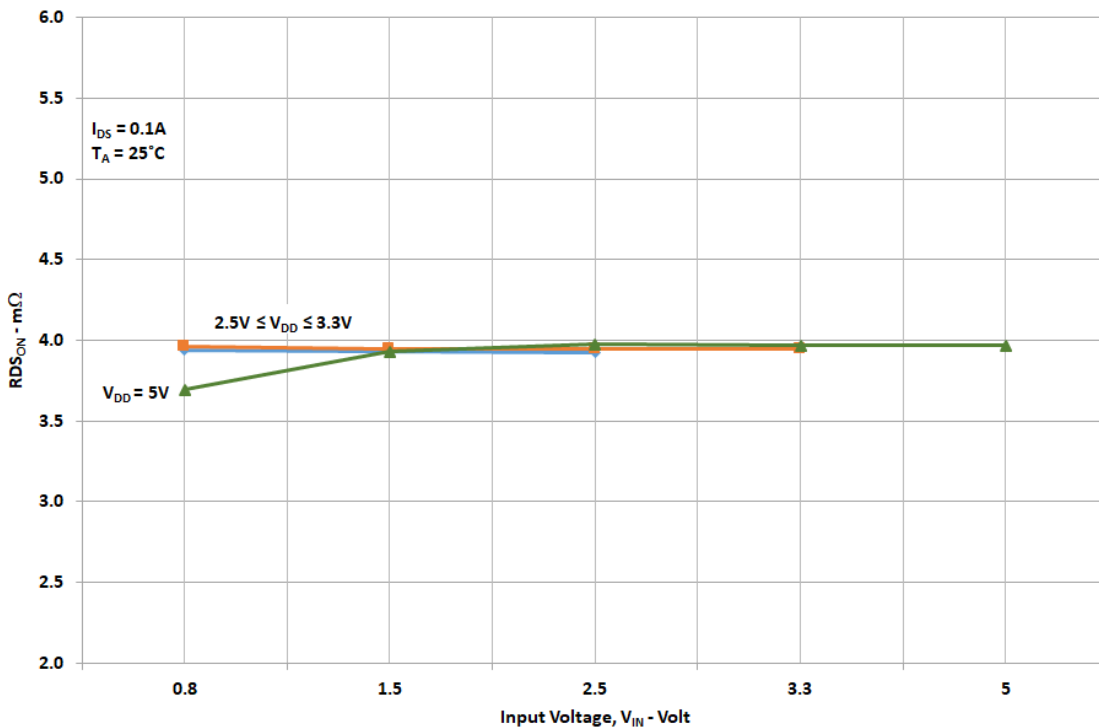

An Ultra-small, 4 mΩ, 2 A Integrated Power Switch with Multiple Protection Features

**V<sub>OUT(SR)</sub> Slew Rate vs. Temperature, V<sub>DD</sub>, V<sub>IN</sub>, and C<sub>SLEW</sub>**

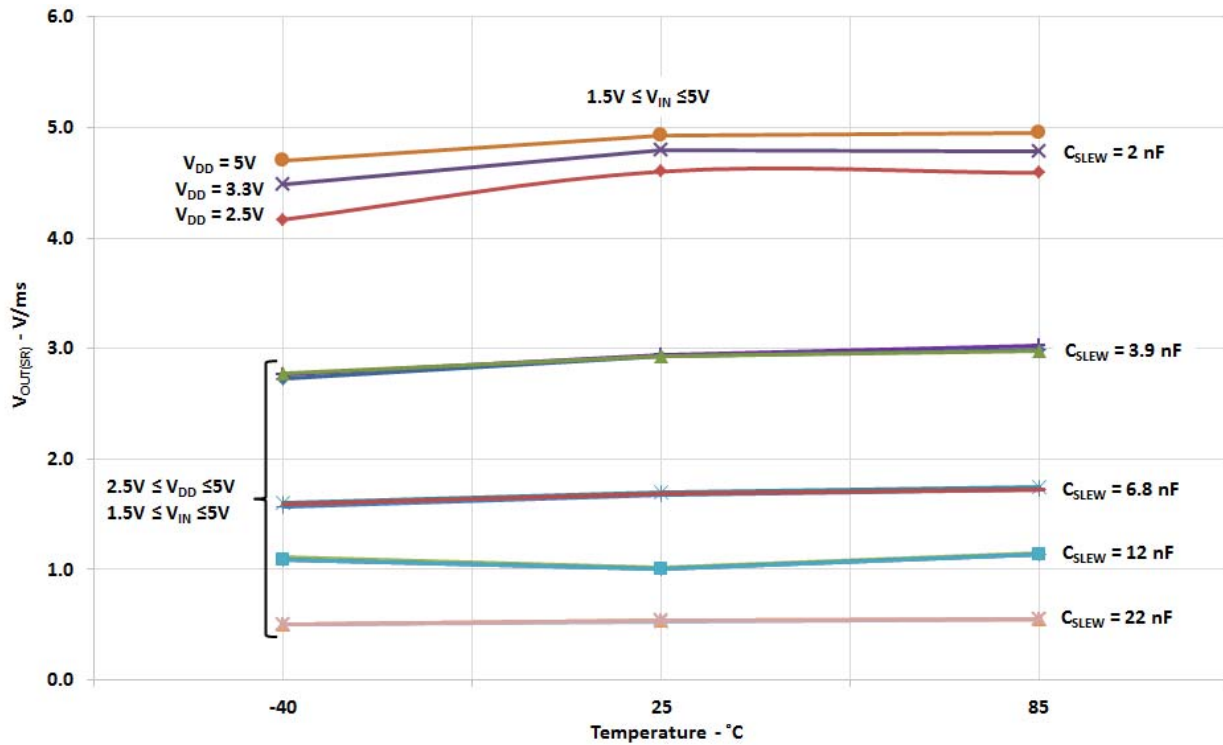

**T<sub>Total\_ON</sub> vs. C<sub>SLEW</sub>, V<sub>IN</sub>, V<sub>DD</sub>, and Temperature**

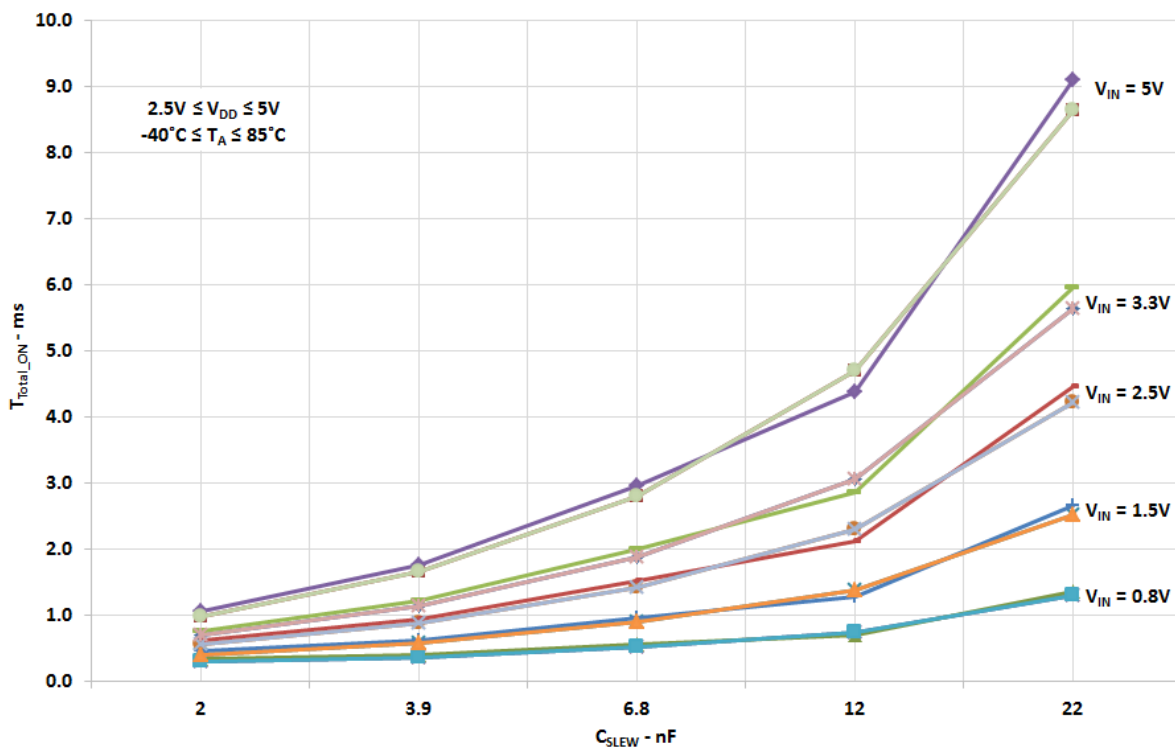

An Ultra-small, 4 mΩ, 2 A Integrated Power Switch with Multiple Protection Features

## $I_{ACL}$ vs. Temperature, $V_{DD}$ , and $V_{IN}$

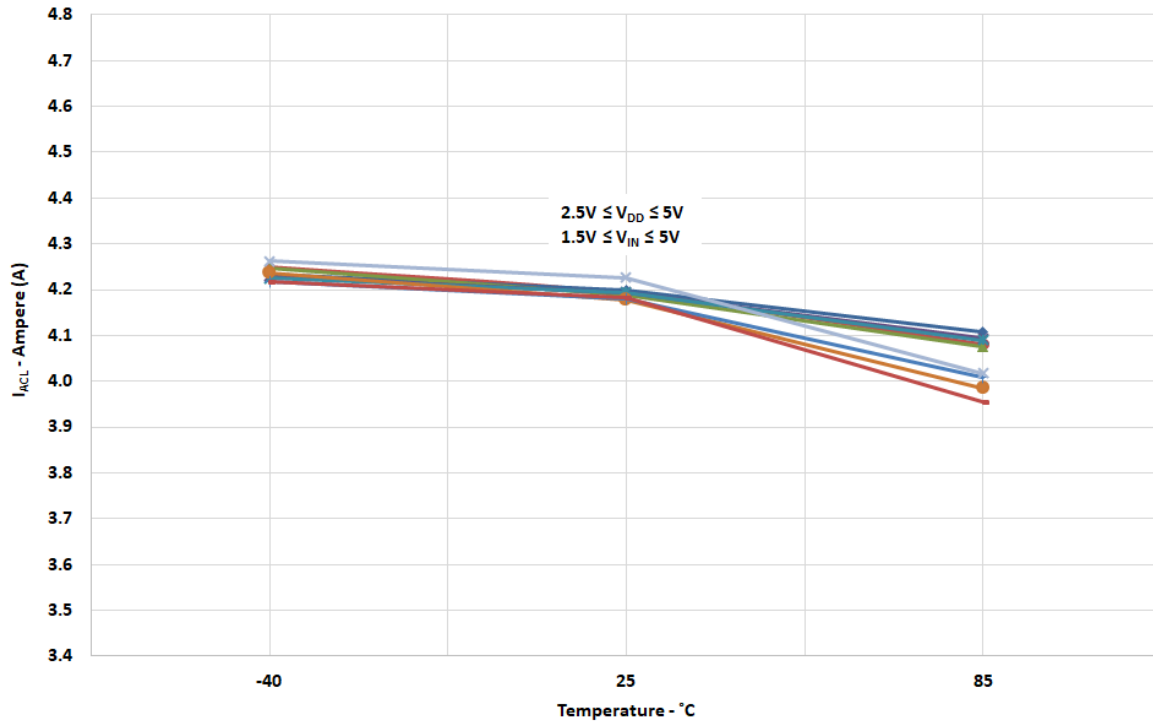

An Ultra-small, 4 mΩ, 2 A Integrated Power Switch with Multiple Protection Features

Timing Diagram - Basic Operation including Active Current Limit Protection

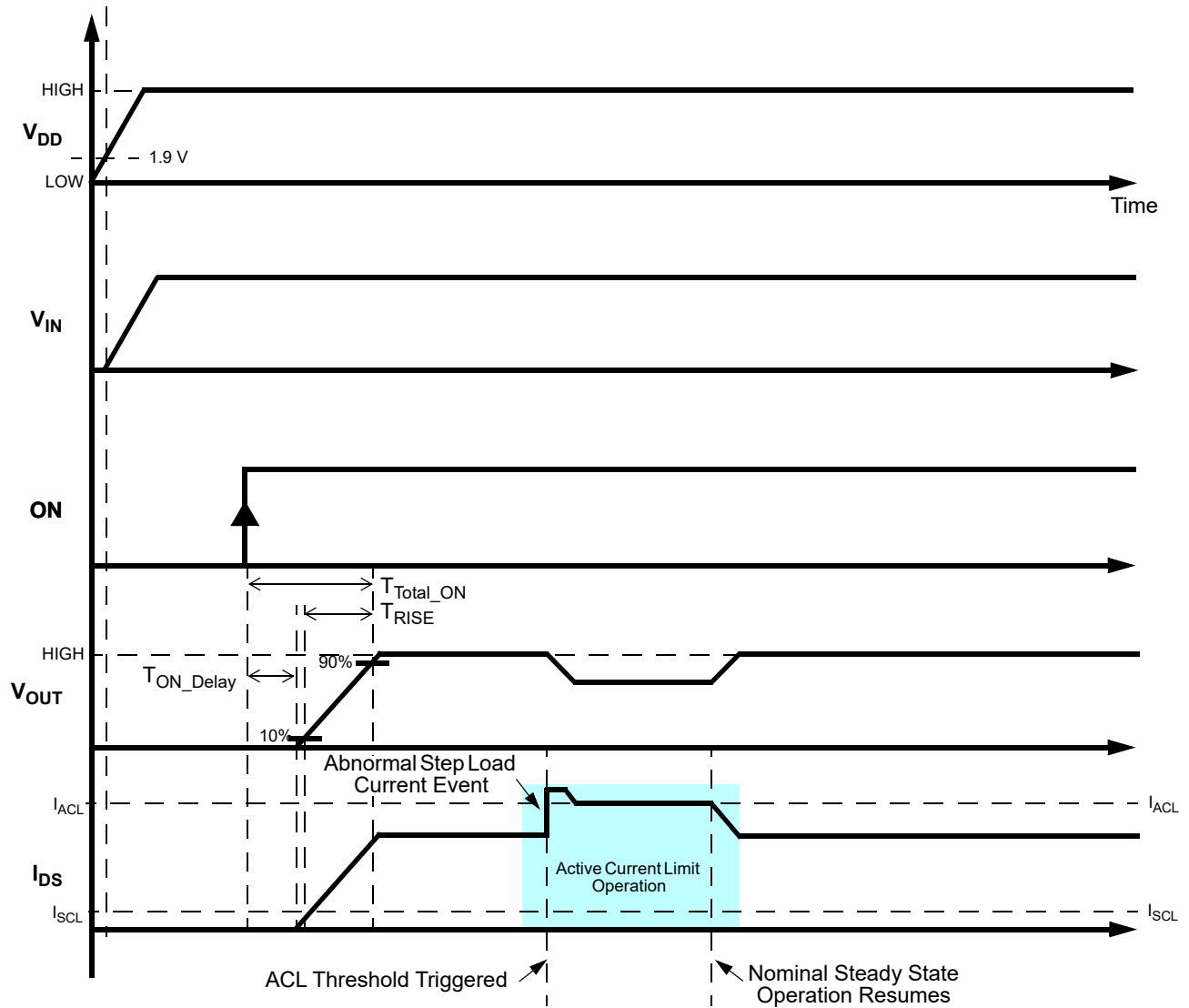



An Ultra-small, 4 mΩ, 2 A Integrated Power Switch with Multiple Protection Features

Timing Diagram - Active Current Limit & Thermal Protection Operation

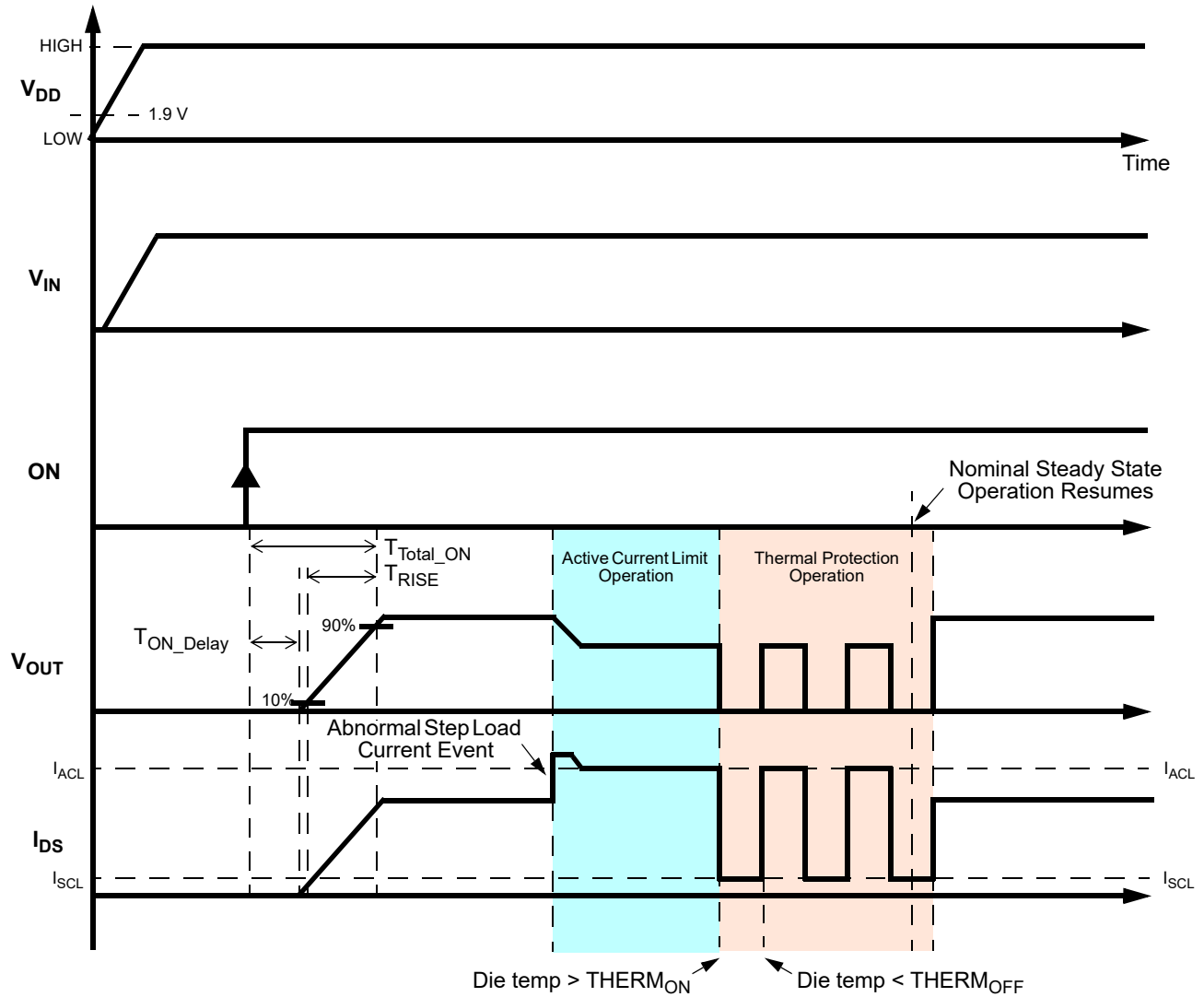

An Ultra-small, 4 mΩ, 2 A Integrated Power Switch with Multiple Protection Features

SLG59M1713V Application Diagram

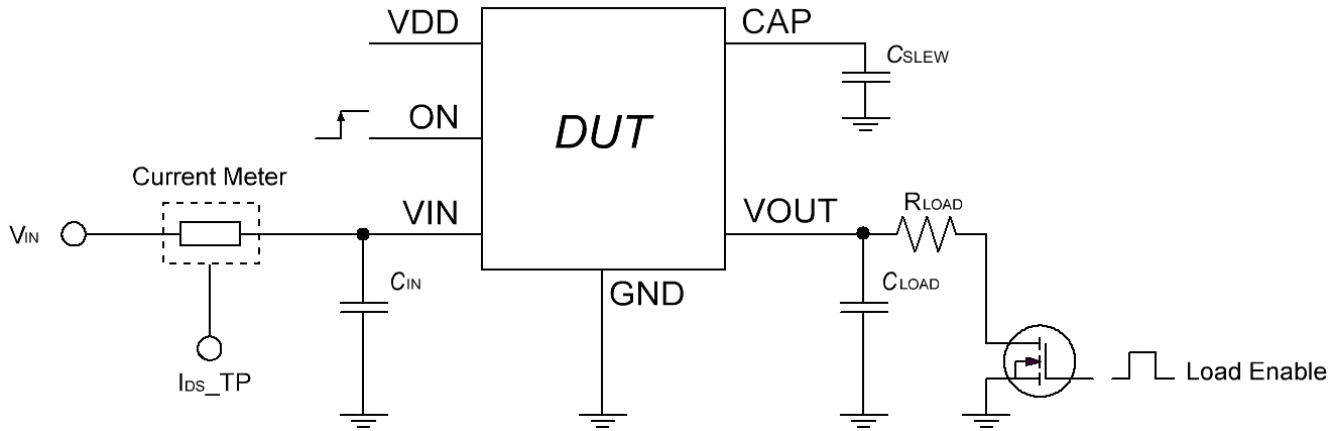

Figure 1. Test setup Application Diagram

Typical Turn-on Waveforms

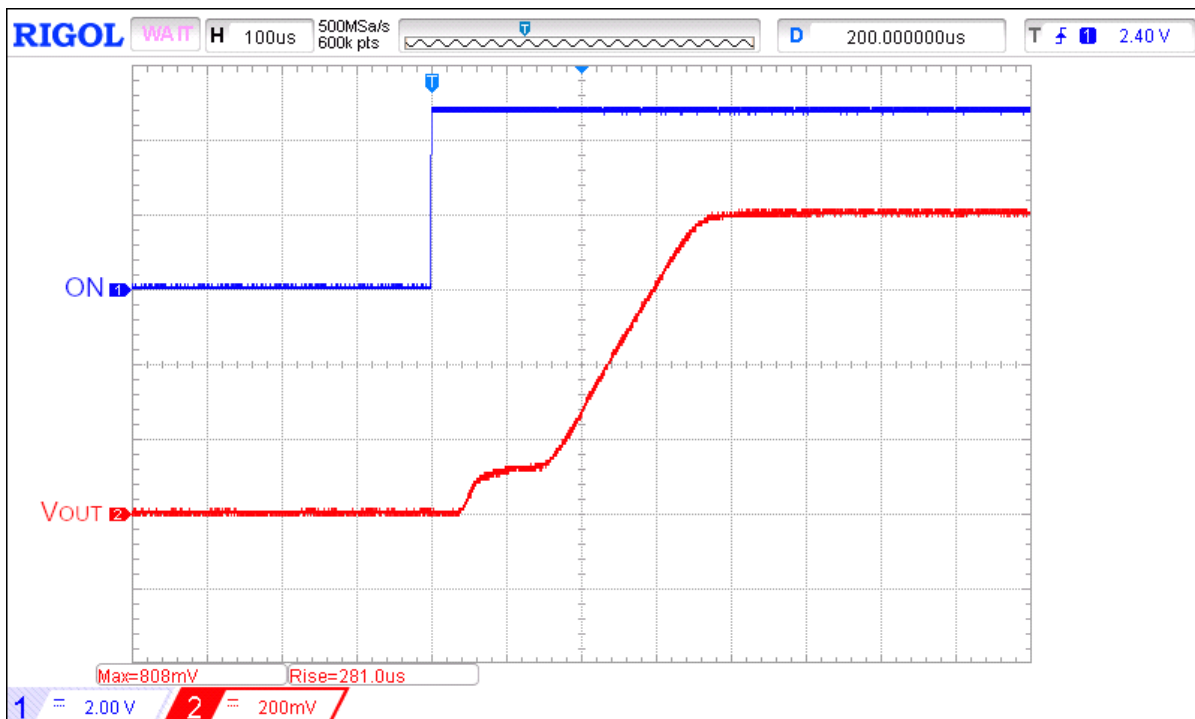

Figure 2. Typical Turn ON operation waveform for  $V_{DD} = 5\text{ V}$ ,  $V_{IN} = 0.8\text{ V}$ ,  $C_{SLEW} = 3.9\text{ nF}$ ,  $C_{LOAD} = 10\text{ }\mu\text{F}$ ,  $R_{LOAD} = 20\text{ }\Omega$

An Ultra-small, 4 mΩ, 2 A Integrated Power Switch with Multiple Protection Features

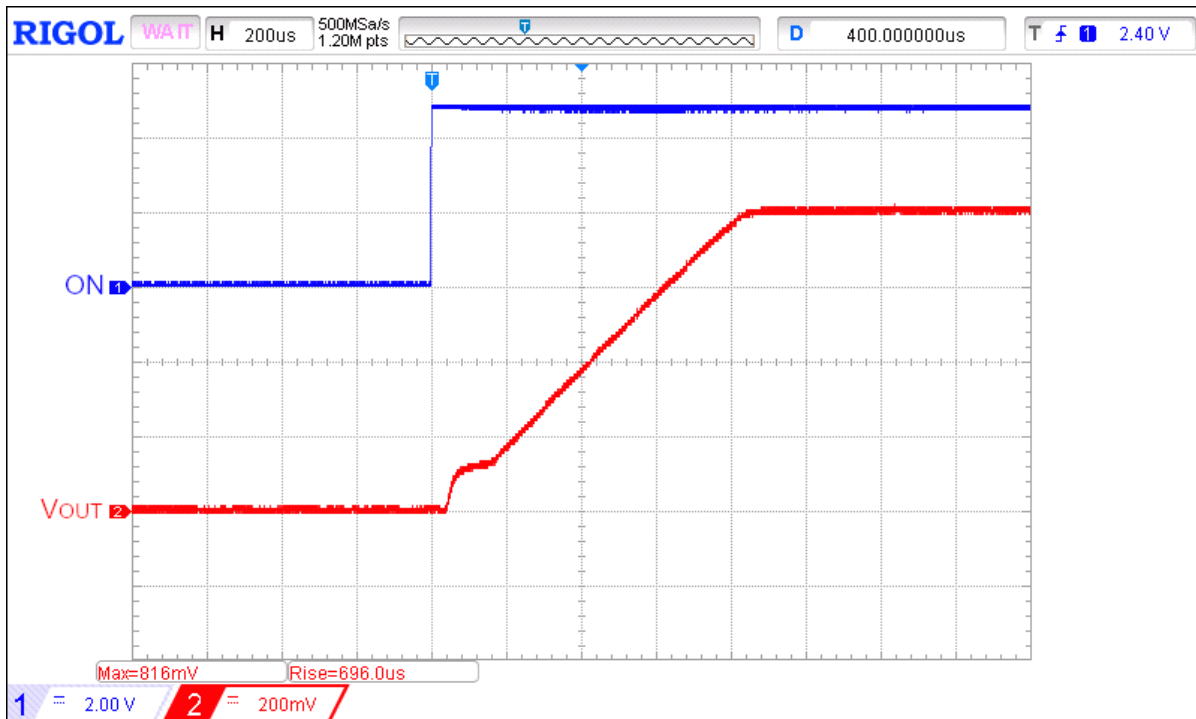

Figure 3. Typical Turn ON operation waveform for  $V_{DD} = 5\text{ V}$ ,  $V_{IN} = 0.8\text{ V}$ ,  $C_{SLEW} = 12\text{ nF}$ ,  $C_{LOAD} = 10\text{ }\mu\text{F}$ ,  $R_{LOAD} = 20\text{ }\Omega$

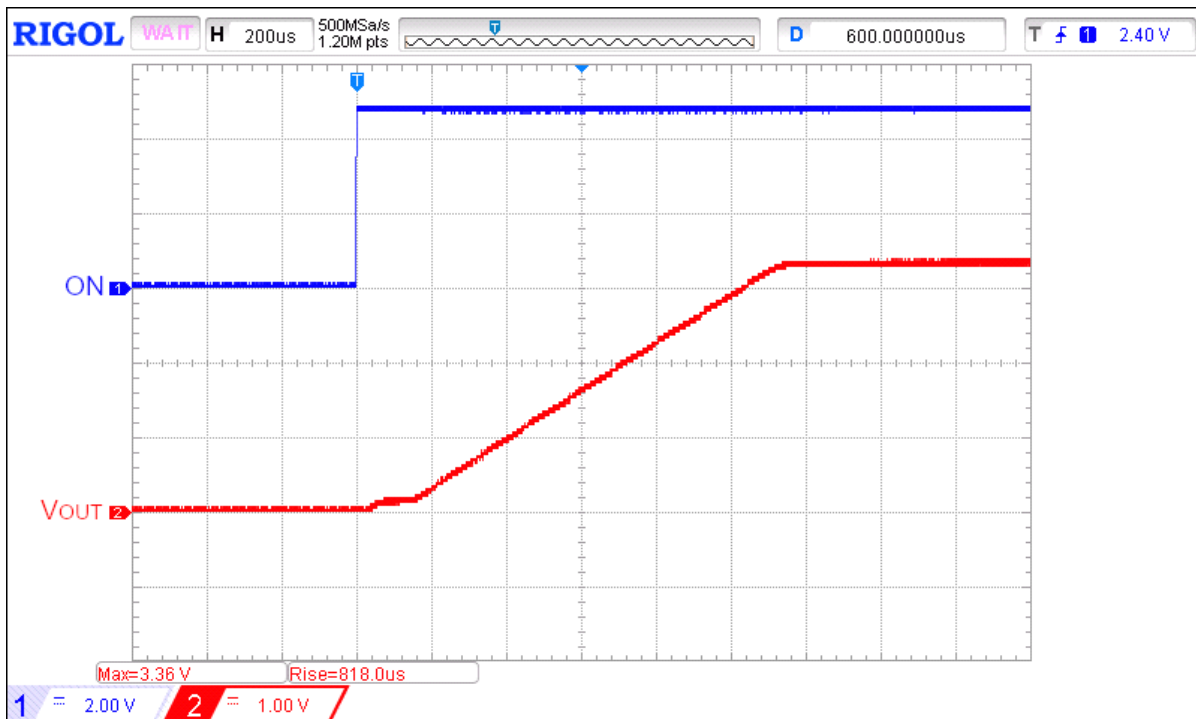

Figure 4. Typical Turn ON operation waveform for  $V_{DD} = 5\text{ V}$ ,  $V_{IN} = 3.3\text{ V}$ ,  $C_{SLEW} = 3.9\text{ nF}$ ,  $C_{LOAD} = 10\text{ }\mu\text{F}$ ,  $R_{LOAD} = 20\text{ }\Omega$

An Ultra-small, 4 mΩ, 2 A Integrated Power Switch with Multiple Protection Features

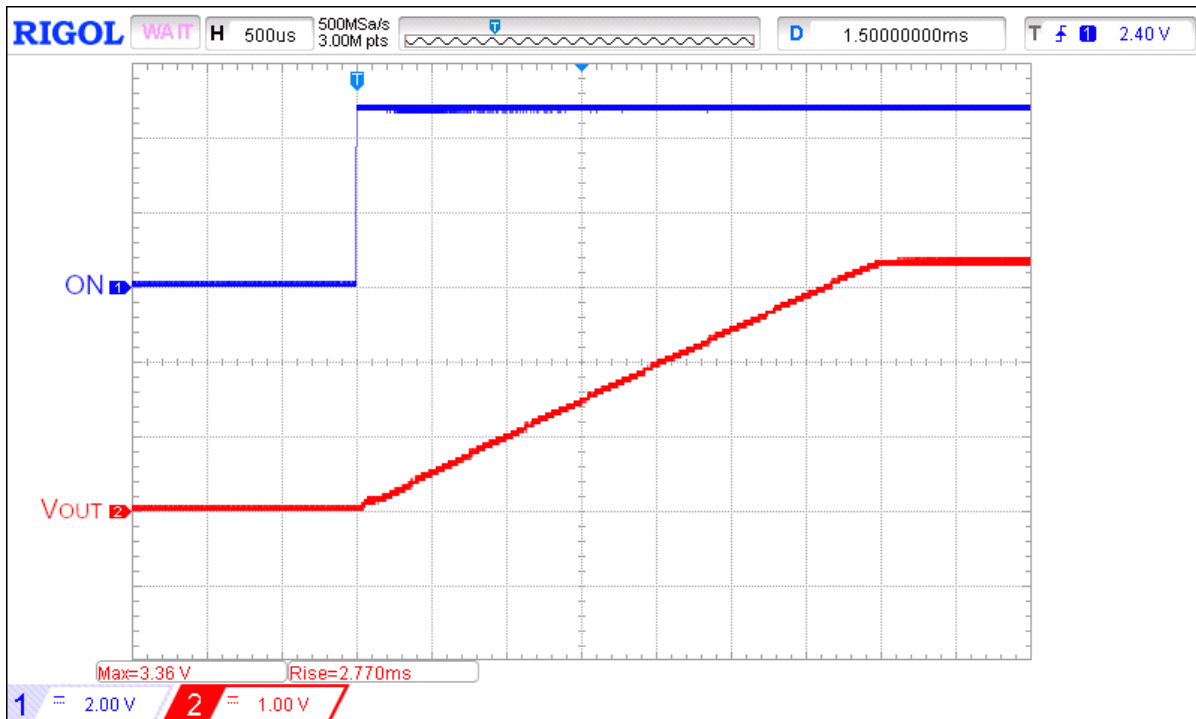

Figure 5. Typical Turn ON operation waveform for  $V_{DD} = 5\text{ V}$ ,  $V_{IN} = 3.3\text{ V}$ ,  $C_{SLEW} = 12\text{ nF}$ ,  $C_{LOAD} = 10\text{ }\mu\text{F}$ ,  $R_{LOAD} = 20\text{ }\Omega$

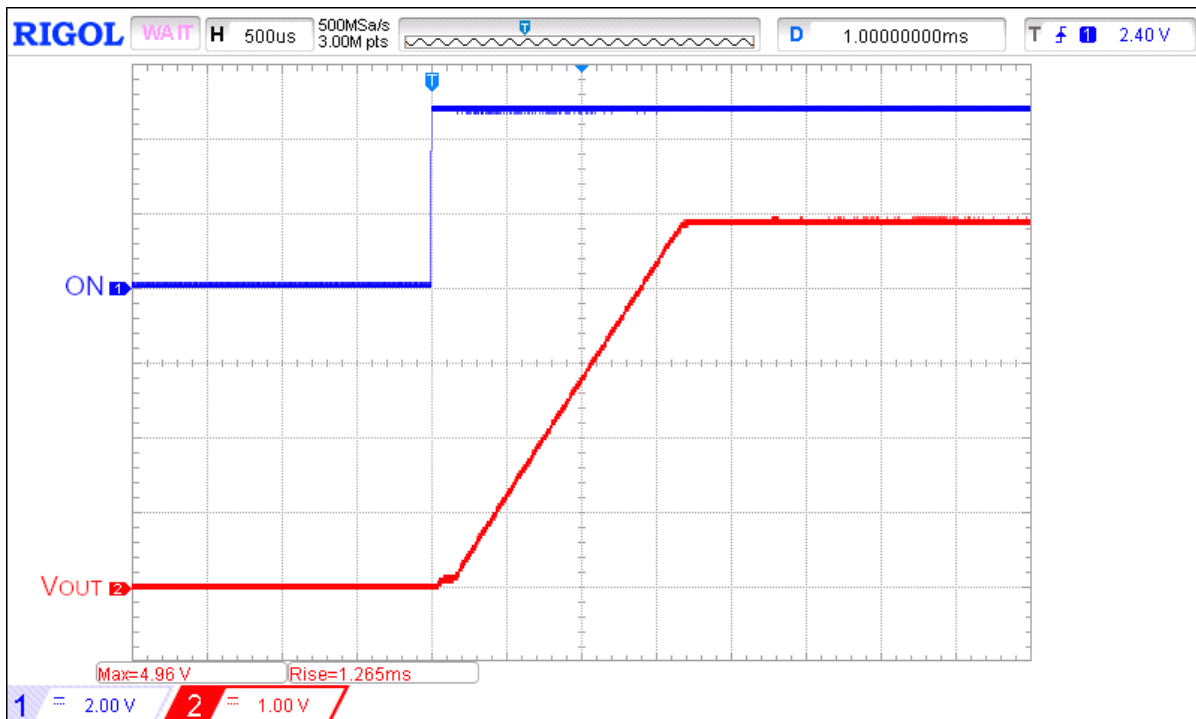

Figure 6. Typical Turn ON operation waveform for  $V_{DD} = 5\text{ V}$ ,  $V_{IN} = 5\text{ V}$ ,  $C_{SLEW} = 3.9\text{ nF}$ ,  $C_{LOAD} = 10\text{ }\mu\text{F}$ ,  $R_{LOAD} = 20\text{ }\Omega$

An Ultra-small, 4 mΩ, 2 A Integrated Power Switch with Multiple Protection Features

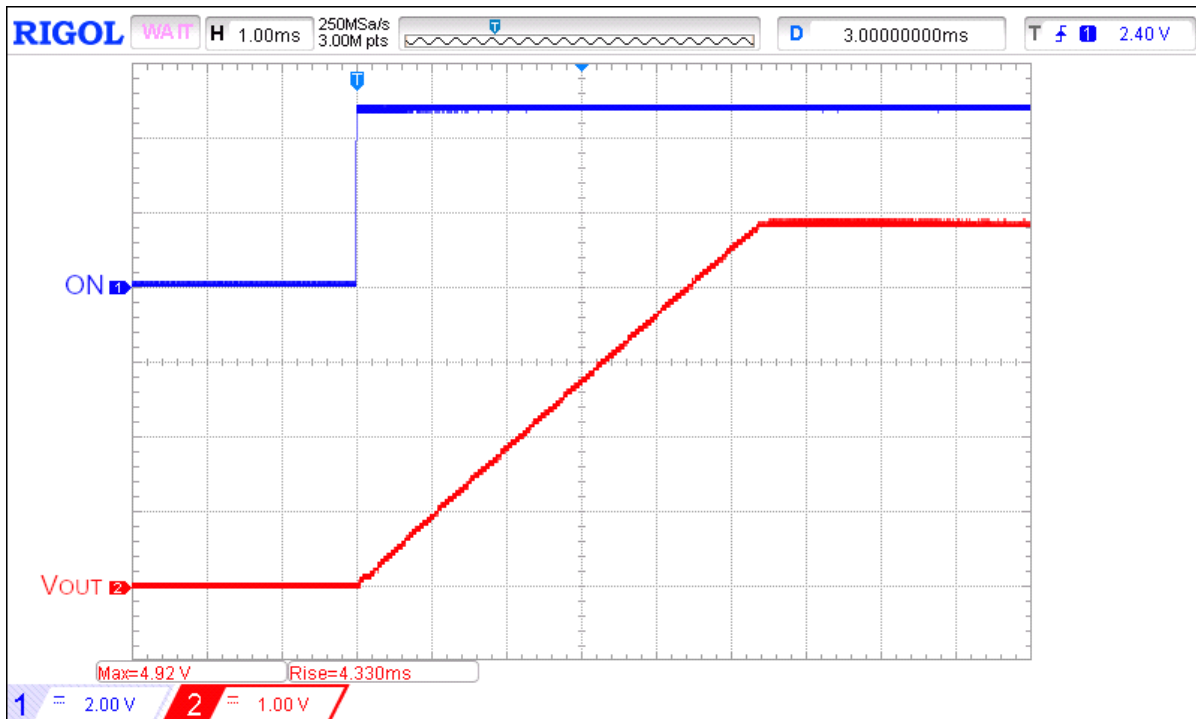

Figure 7. Typical Turn ON operation waveform for  $V_{DD} = 5\text{ V}$ ,  $V_{IN} = 5\text{ V}$ ,  $C_{SLEW} = 12\text{ nF}$ ,  $C_{LOAD} = 10\text{ }\mu\text{F}$ ,  $R_{LOAD} = 20\text{ }\Omega$

Typical Turn-off Waveforms

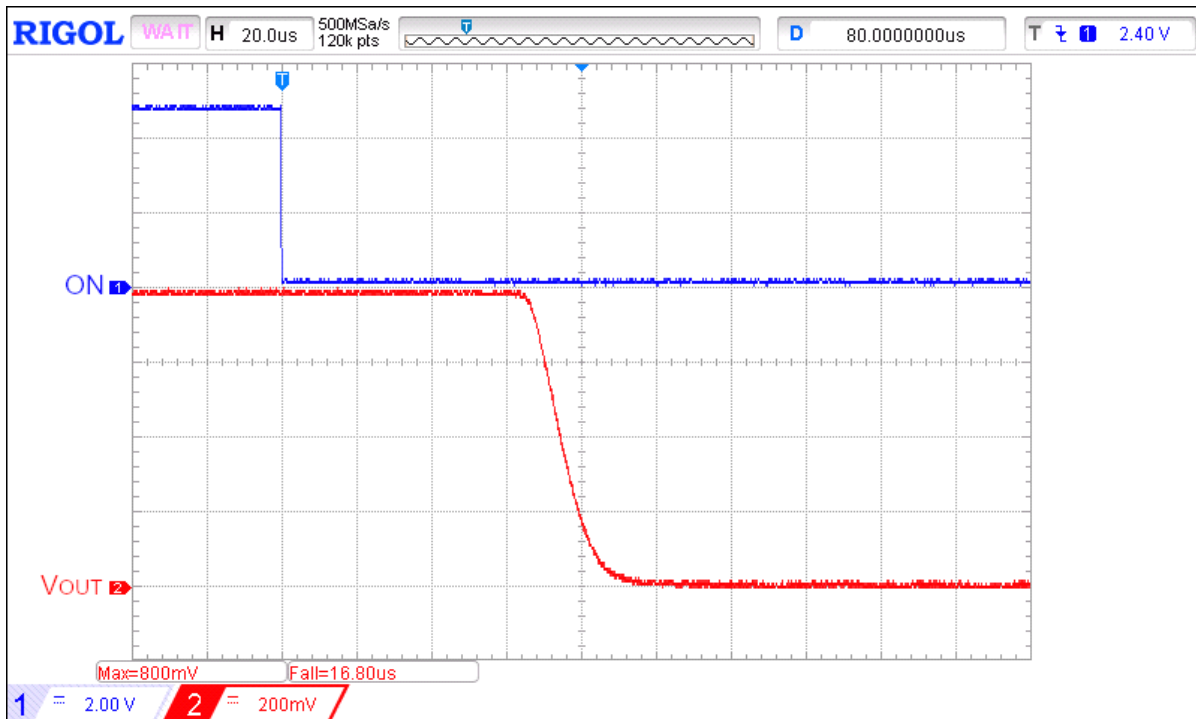

Figure 8. Typical Turn OFF operation waveform for  $V_{DD} = 5\text{ V}$ ,  $V_{IN} = 0.8\text{ V}$ , no  $C_{LOAD}$ ,  $R_{LOAD} = 20\text{ }\Omega$

An Ultra-small, 4 mΩ, 2 A Integrated Power Switch with Multiple Protection Features

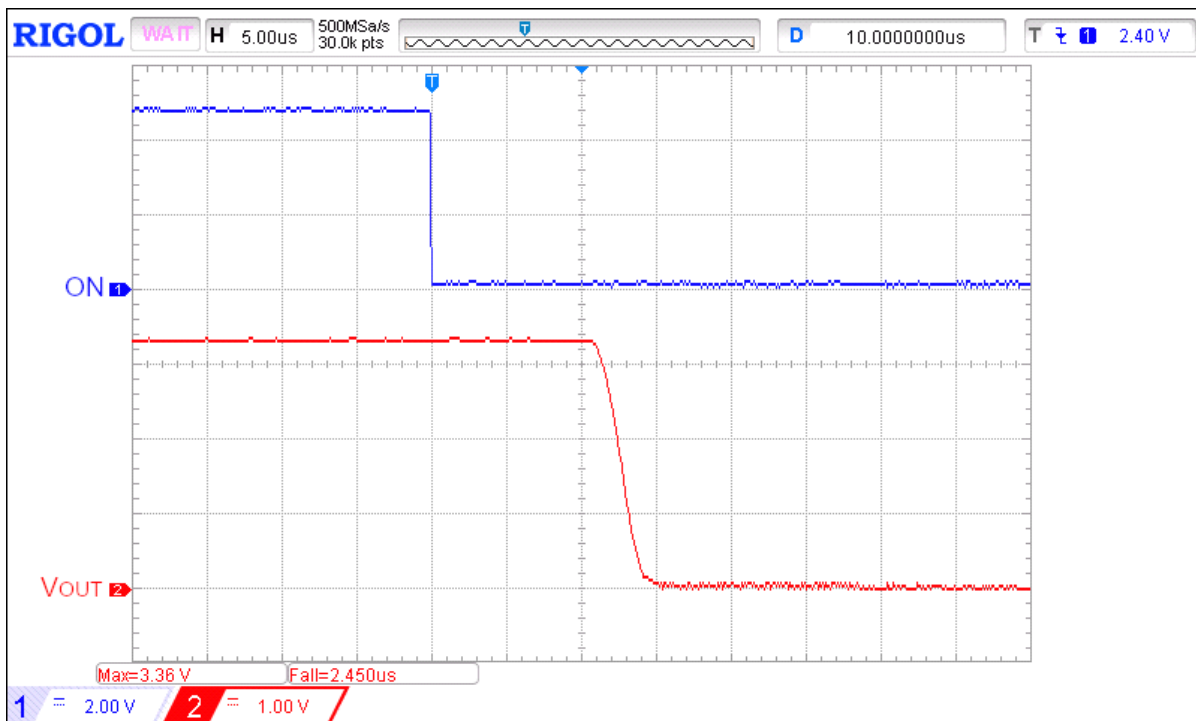

Figure 9. Typical Turn OFF operation waveform for  $V_{DD} = 5\text{ V}$ ,  $V_{IN} = 3.3\text{ V}$ , no  $C_{LOAD}$ ,  $R_{LOAD} = 20\ \Omega$

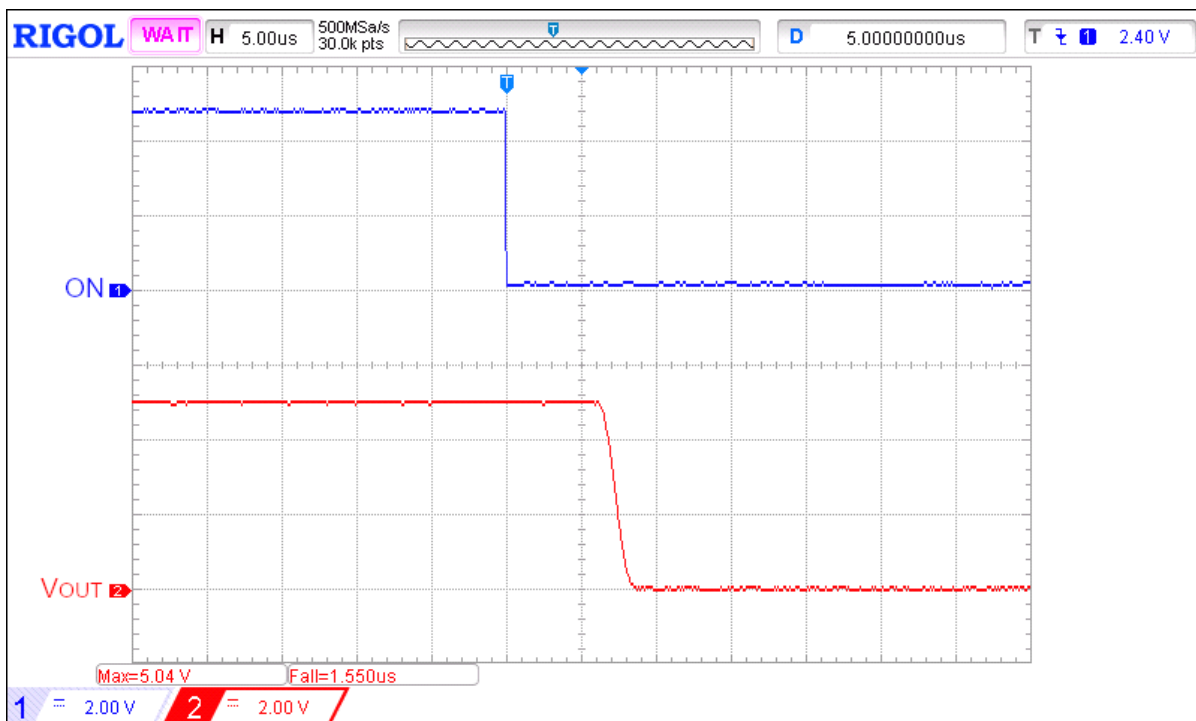

Figure 10. Typical Turn OFF operation waveform for  $V_{DD} = 5\text{ V}$ ,  $V_{IN} = 5\text{ V}$ , no  $C_{LOAD}$ ,  $R_{LOAD} = 20\ \Omega$

An Ultra-small, 4 mΩ, 2 A Integrated Power Switch with Multiple Protection Features

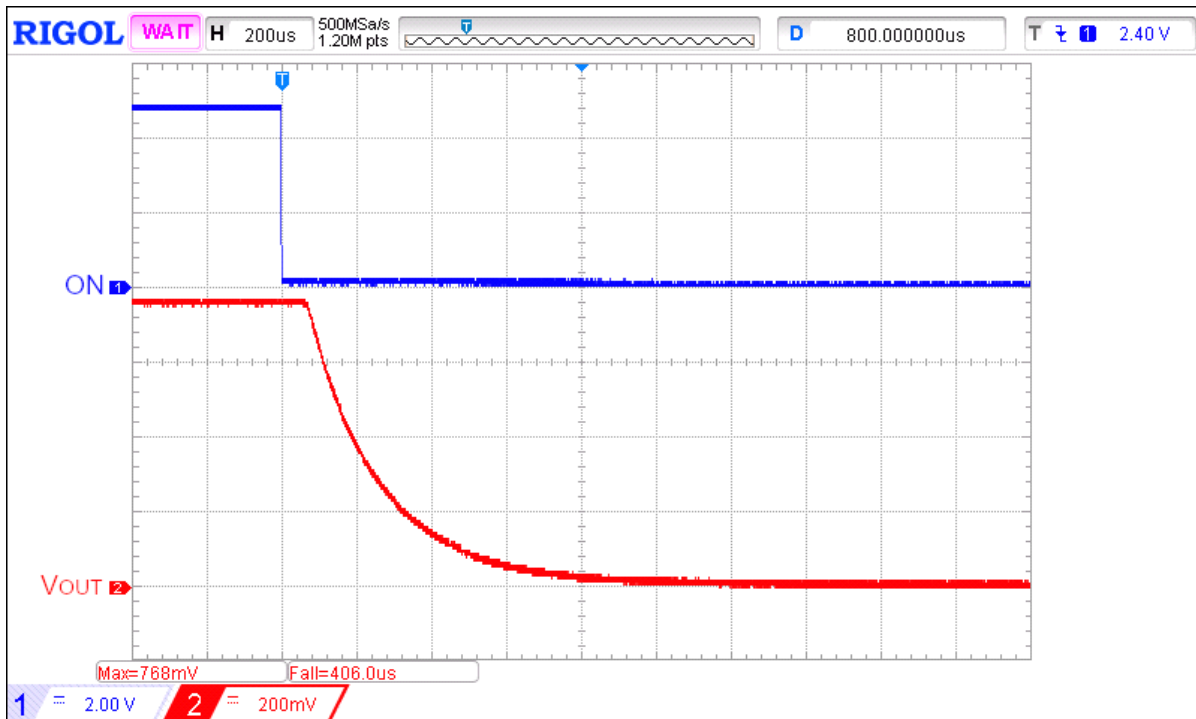

Figure 11. Typical Turn OFF operation waveform for  $V_{DD} = 5\text{ V}$ ,  $V_{IN} = 0.8\text{ V}$ ,  $C_{LOAD} = 10\text{ }\mu\text{F}$ ,  $R_{LOAD} = 20\text{ }\Omega$

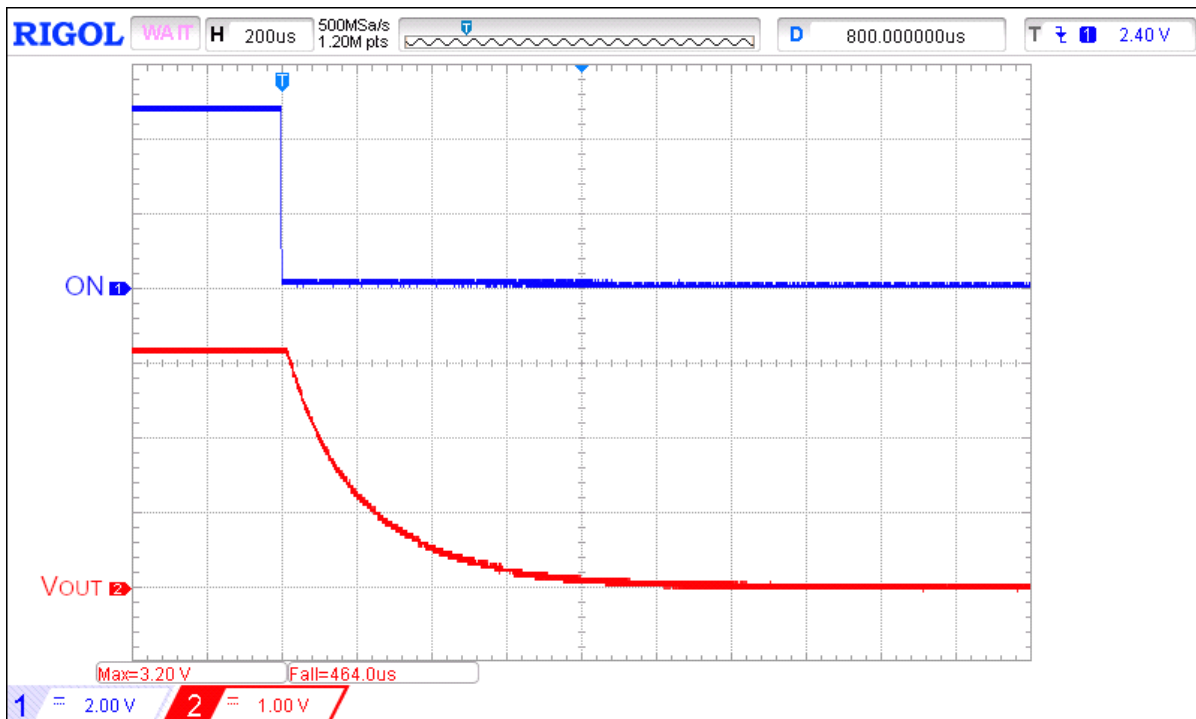

Figure 12. Typical Turn OFF operation waveform for  $V_{DD} = 5\text{ V}$ ,  $V_{IN} = 3.3\text{ V}$ ,  $C_{LOAD} = 10\text{ }\mu\text{F}$ ,  $R_{LOAD} = 20\text{ }\Omega$

An Ultra-small, 4 mΩ, 2 A Integrated Power Switch with Multiple Protection Features

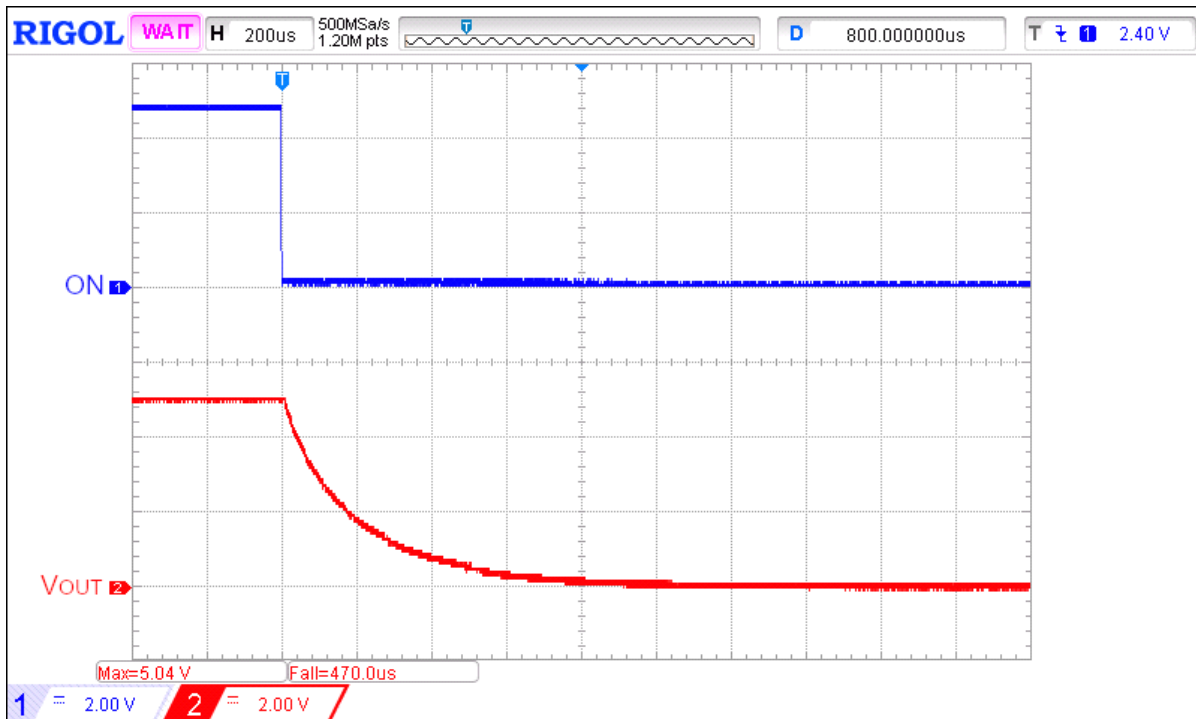

Figure 13. Typical Turn OFF operation waveform for  $V_{DD} = 5\text{ V}$ ,  $V_{IN} = 5\text{ V}$ ,  $C_{LOAD} = 10\text{ }\mu\text{F}$ ,  $R_{LOAD} = 20\text{ }\Omega$

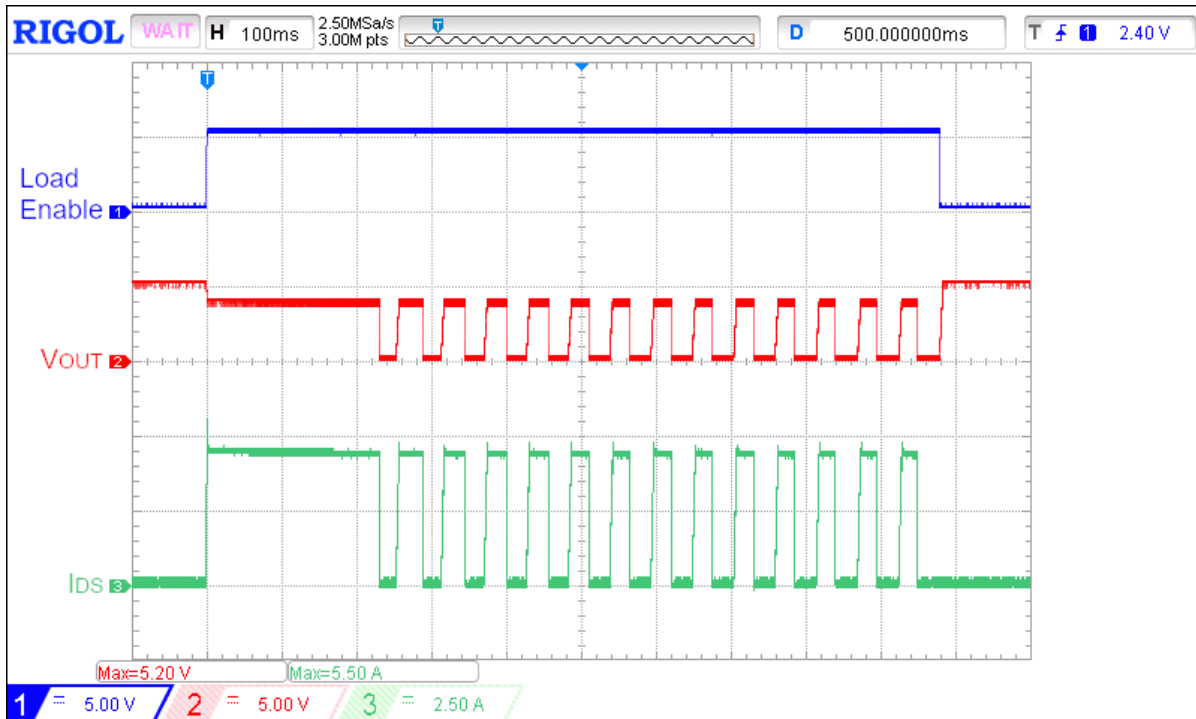

Figure 14. Typical ACL operation waveform for  $V_{DD} = 5\text{ V}$ ,  $V_{IN} = 5\text{ V}$ ,  $C_{LOAD} = 10\text{ }\mu\text{F}$ ,  $I_{ACL} = 4\text{ A}$



## An Ultra-small, 4 mΩ, 2 A Integrated Power Switch with Multiple Protection Features

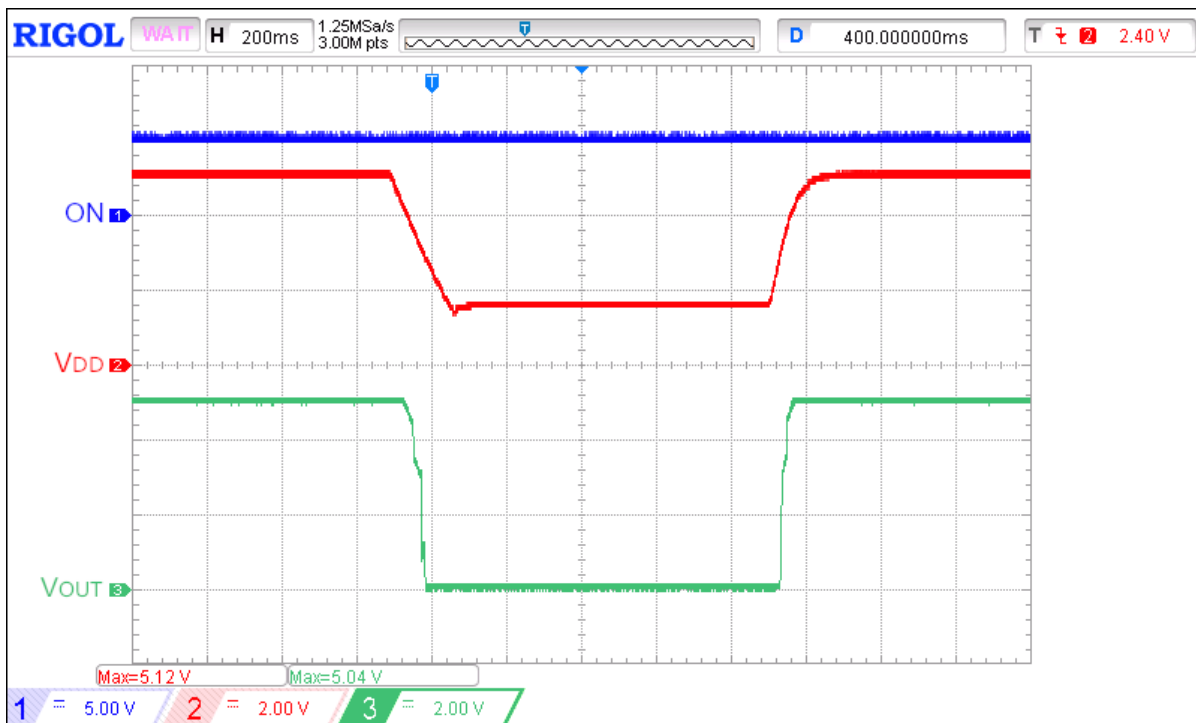

Figure 15. Typical UVP operation waveform for  $V_{DD} = 5\text{ V}$ ,  $V_{IN} = 5\text{ V}$ ,  $V_{DD}$  step from 5 V to 1.5 V

## An Ultra-small, 4 mΩ, 2 A Integrated Power Switch with Multiple Protection Features

### SLG59M1713V Power-Up/Power-Down Sequence Considerations

To ensure glitch-free power-up under all conditions, apply  $V_{DD}$  first, followed by  $V_{IN}$  after  $V_{DD}$  exceeds 1.9 V. Then allow  $V_{IN}$  to reach 90% of its max value before toggling the ON pin from Low-to-High. Likewise, power-down in reverse order.

If  $V_{DD}$  and  $V_{IN}$  need to be powered up simultaneously, glitching can be minimized by having a suitable load capacitor. A 10  $\mu\text{F}$   $C_{LOAD}$  will prevent glitches for rise times of  $V_{DD}$  and  $V_{IN}$  less than 2 ms.

If the ON pin is toggled HIGH before  $V_{DD}$  and  $V_{IN}$  have reached their steady-state values, the IPS timing parameters may differ from datasheet specifications.

The slew rate of output  $V_{OUT}$  follows a linear ramp set by a capacitor connected to the CAP pin. A larger capacitor value at the CAP pin produces a slower ramp, reducing inrush current from capacitive loads.

### SLG59M1713V Current Limiting Operation

The SLG59M1713V has two types of current limiting triggered by the output  $V_{OUT}$  voltage.

#### 1. Standard Current Limiting Mode (with Thermal Shutdown Protection)

When the  $V_{OUT}$  voltage  $> 300$  mV, the output current is initially limited to the Active Current Limit ( $I_{ACL}$ ) specification listed in the Electrical Characteristics table. The ACL monitor's response time is very fast and is triggered within a few microseconds to sudden (transient) changes in load current. When a load current overload is detected, the ACL monitor increases the FET resistance to keep the current from exceeding the power switch's  $I_{ACL}$  threshold. During active current-limit operation,  $V_{OUT}$  is also reduced by  $I_{ACL} \times RDS_{ON(ACL)}$ . This observed behavior is illustrated in the timing diagrams on Pages 8 and 9.

However, if a load-current overload condition persists where the die temperature rises because of the increased FET resistance, the power switch's internal Thermal Shutdown Protection circuit can be activated. If the die temperature exceeds the listed  $THERM_{ON}$  specification, the FET is shut OFF completely, thereby allowing the die to cool. When the die cools to the listed  $THERM_{OFF}$  temperature threshold, the FET is allowed to turn back on. This process may repeat as long as the output current overload condition persists.

#### 2. Short Circuit Current Limiting Mode (with Thermal Shutdown Protection)

When the  $V_{OUT}$  voltage  $< 300$  mV (which is the case with a hard short, such as a solder bridge on the power rail), the power switch's internal Short-circuit Current Limit (SCL) monitor limits the FET current to approximately 500 mA (the  $I_{SCL}$  threshold). While the internal Thermal Shutdown Protection circuit remains enabled and since the  $I_{SCL}$  threshold is much lower than the  $I_{ACL}$  threshold, thermal shutdown protection may become activated only at higher ambient temperatures.

### SLG59M1713V Start-up Inrush Current Considerations with Capacitive Loads

In distributed power applications, the SLG59M1713V is generally implemented on the outboard or downstream side of switching regulator dc/dc converters with internal overcurrent protection. As an adjustable output voltage slew-rate, integrated power switch, it is important to understand the start-up operation of the SLG59M1713V with capacitive loads. An equivalent circuit of the SLG59M1713V's slew-rate control loop with capacitors at its VIN and VOUT pins is shown in Figure 16:

An Ultra-small, 4 mΩ, 2 A Integrated Power Switch with Multiple Protection Features

SLG59M1713V Start-up Inrush Current Considerations with Capacitive Loads (continued)

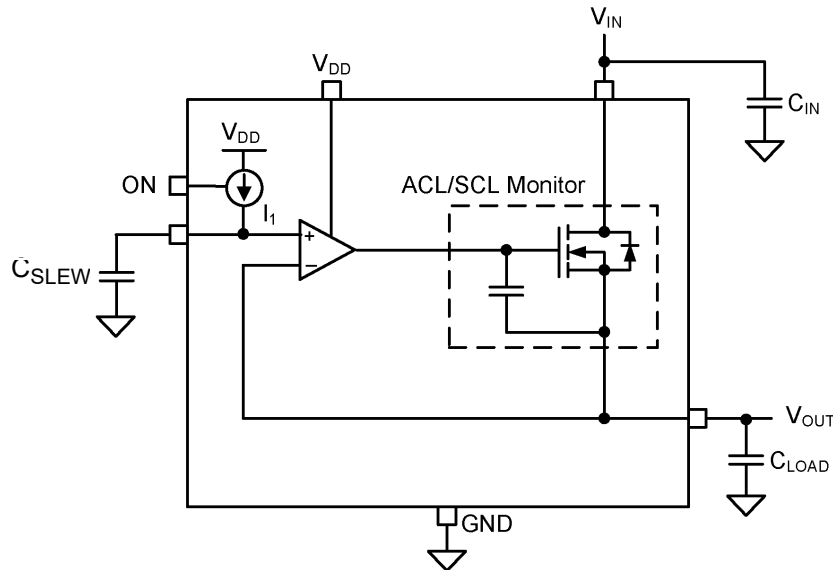

Figure 16. SLG59M1713V’s Equivalent Slew-rate Control Loop Circuit

For a desired  $V_{OUT}$  slew-rate ( $V_{OUT(SR)}$ ), a corresponding  $C_{SLEW}$  value is selected. At the  $V_{OUT}$  pin and with  $ON = LOW$ , the internal FET is OFF,  $V_{OUT}$  is initially at 0 V, and there is no stored charge on  $C_{LOAD}$ . When a low-to-high transition is applied to the IC’s  $ON$  pin, an internal current source ( $I_1$ ) is enabled which, in turn, charges the external slew-rate capacitor,  $C_{SLEW}$ . The SLG59M1713V’s internal micropower op amp sets the circuit’s  $V_{OUT(SR)}$  based on the slew rate of the nodal voltage at its non-inverting pin (the voltage at the CAP pin).

As a function of  $V_{OUT(SR)}$  and  $C_{LOAD}$ , a 1st-order expression for the circuit’s FET current (and inrush current) when a low-to-high transition on the  $ON$  pin is applied becomes:

$$\text{Start-up Current } I_{DS} \text{ or } I_{INRUSH} = V_{OUT(SR)} \times C_{LOAD}$$

From the expression above and for a given  $V_{OUT(SR)}$ ,  $C_{LOAD}$  determines the magnitude of the inrush current; that is, for large values of  $C_{LOAD}$ , large inrush currents can result. If the inrush currents are large enough to trigger the overcurrent protection of an upstream dc/dc converter, the system can be shut down.

In applications where the desired  $V_{OUT(SR)}$  is fast and  $C_{LOAD}$  is very large ( $>200 \mu F$ ), there is a secondary effect on the observed  $V_{OUT(SR)}$  attributed to the SLG59M1713V’s internal short-circuit current limit monitor (its SCL monitor). If the resultant inrush current is larger than the IC’s  $I_{SCL}$  threshold, the SCL current monitor limits the inrush current and the current to charge  $C_{LOAD}$  until the  $I_{SCL}$  OFF threshold is crossed ( $\sim 0.3V$ ). During the time the SCL monitor’s been activated, the inrush current profile may exhibit an observable reduction in  $V_{OUT(SR)}$  as shown in Figure 17 where  $C_{SLEW}$  was set to 1.5 nF and 470  $\mu F$  was chosen for  $C_{LOAD}$ .

An Ultra-small, 4 mΩ, 2 A Integrated Power Switch with Multiple Protection Features

## SLG59M1713V Start-up Inrush Current Considerations with Capacitive Loads (continued)

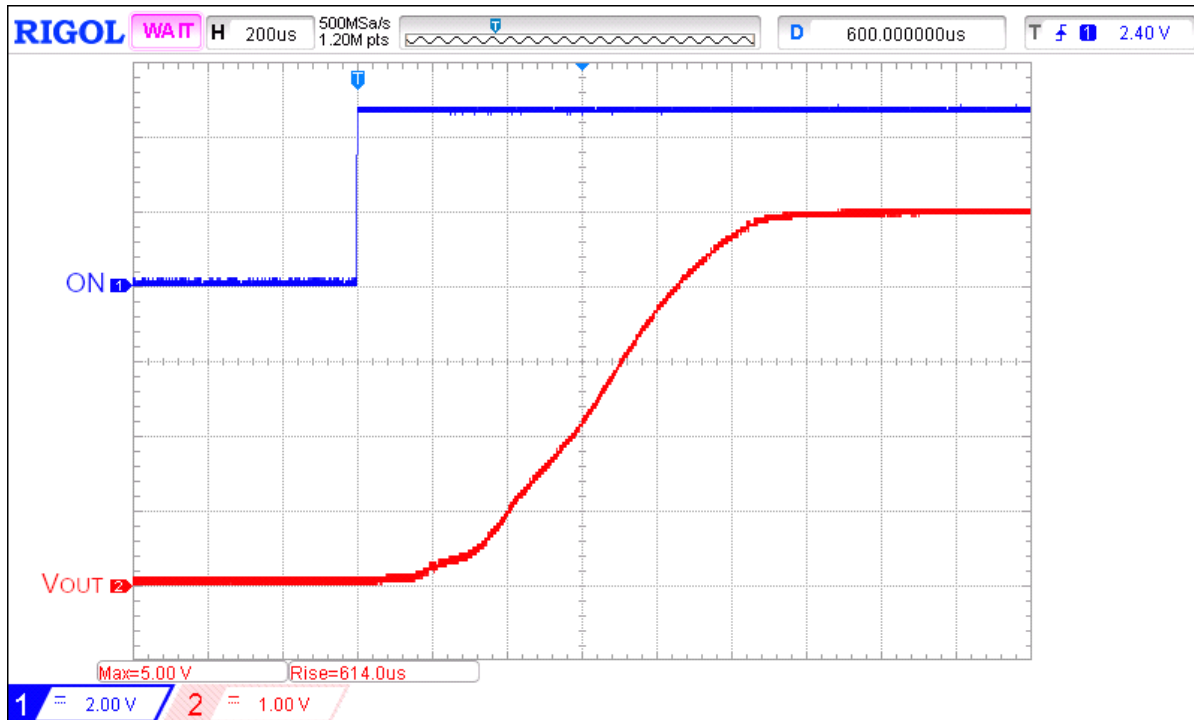

**Figure 17.** A SLG59M1713V with  $C_{SLEW}$  set to 1.5 nF and 470 μF for  $C_{LOAD}$ .  $C_{LOAD}$ -to- $C_{SLEW}$  ratio is greater than 33,600. Note that the internal SCL monitor's been triggered and  $V_{OUT(SR)}$  is reduced until  $V_{OUT}$  reaches ~0.3 V.

A closer analysis of the IC's internal slew-control large-scale yields the following:

$$\frac{I_{SCL}}{C_{LOAD}} = M_{SR} \times \frac{I_1}{C_{SLEW}}$$

where

- $I_{SCL}$  = IC's short-circuit current limit threshold, typically 0.5 A;
- $M_{SR}$  = An internal slew-rate multiplier from the IC's CAP pin to the VOUT pin;
- $I_1$  = An internal current source to charge the external capacitor ( $C_{SLEW}$ ).

Rearranging the equation to isolate both  $C_{LOAD}$  and  $C_{SLEW}$  yields the following:

$$\frac{C_{LOAD}}{C_{SLEW}} = \frac{I_{SCL}}{I_1 \times M_{SR}}$$

For the SLG59M1713V device, the right-hand side of the expression is approximately 33,600 after taking into account part-to-part variations because of process, voltage, and temperature.

Referring to the configuration of [Figure 17](#)'s scope capture, the  $C_{LOAD}$ -to- $C_{SLEW}$  ratio is 313,333 (470 μF/1.5 nF) where it is evident that the SCL monitor circuit is charging  $C_{LOAD}$  shortly after a low-to-high ON transition. If it is desired to avoid a reduction in  $V_{OUT(SR)}$ , the choices are decreasing  $C_{LOAD}$  and/or increasing  $C_{SLEW}$  so that the ratio is always less than 33,600 including taking into account external capacitor tolerances for initial accuracy and temperature.

As shown in [Figure 18](#), it was chosen to reduce  $V_{OUT(SR)}$  by increasing  $C_{SLEW}$  to 15 nF while keeping  $C_{LOAD}$  at 470 μF. With this configuration, the ratio of  $C_{LOAD}$  to  $C_{SLEW}$  is about 31,333 (smaller than 33,600). Upon a low-to-high transition on the ON pin, the  $V_{OUT}$  increases smoothly with no evidence of SCL monitor's interaction.

An Ultra-small, 4 mΩ, 2 A Integrated Power Switch with Multiple Protection Features

SLG59M1713V Start-up Inrush Current Considerations with Capacitive Loads (continued)

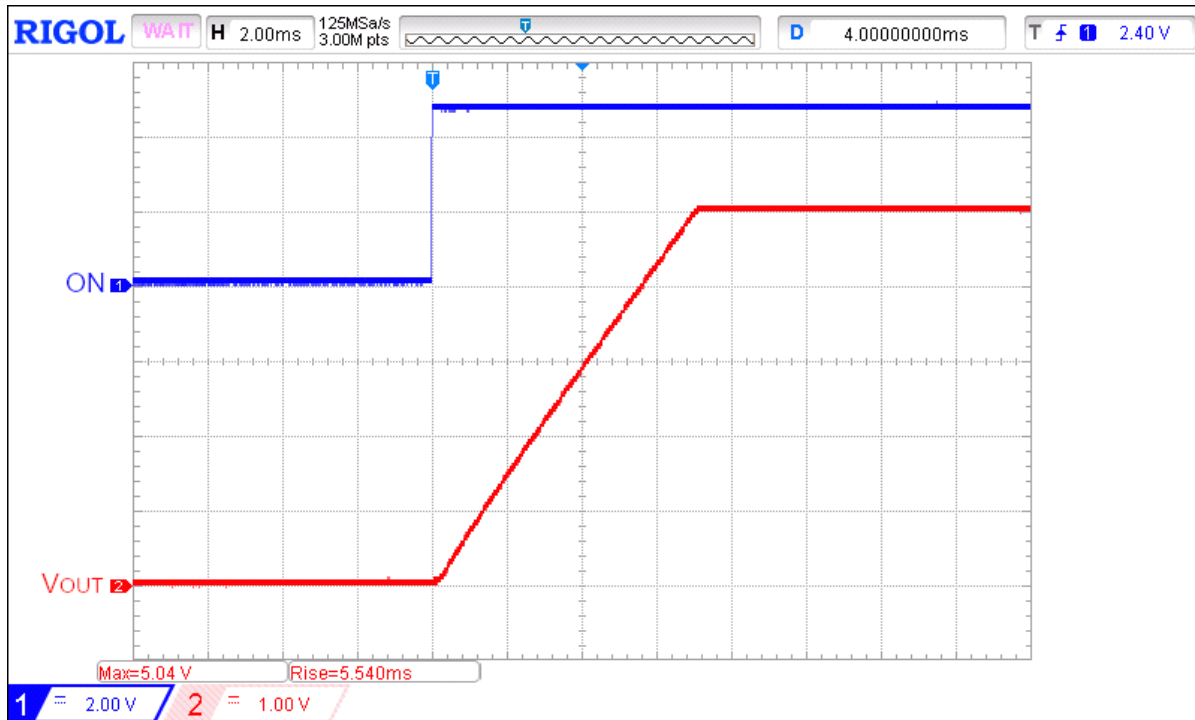

Figure 18. A SLG59M1713V with C<sub>SLEW</sub> set to 15 nF and 470 μF retained for C<sub>LOAD</sub>. C<sub>LOAD</sub>-to-C<sub>SLEW</sub> ratio is smaller than 33,600. Note smooth V<sub>OUT</sub> transition.

Power Dissipation

The junction temperature of the SLG59M1713V depends on different factors such as board layout, ambient temperature, and other environmental factors. The primary contributor to the increase in the junction temperature of the SLG59M1713V is the power dissipation of its power MOSFET. Its power dissipation and the junction temperature in nominal operating mode can be calculated using the following equations:

$$PD = RDS_{ON} \times I_{DS}^2$$

where:

- PD = Power dissipation, in Watts (W)
- RDS<sub>ON</sub> = Power MOSFET ON resistance, in Ohms (Ω)
- I<sub>DS</sub> = Output current, in Amps (A)

and

$$T_J = PD \times \theta_{JA} + T_A$$

where:

- T<sub>J</sub> = Junction temperature, in Celsius degrees (°C)
- θ<sub>JA</sub> = Package thermal resistance, in Celsius degrees per Watt (°C/W)
- T<sub>A</sub> = Ambient temperature, in Celsius degrees (°C)

## An Ultra-small, 4 mΩ, 2 A Integrated Power Switch with Multiple Protection Features

### Power Dissipation (continued)

During active current-limit operation, the SLG59M1713V's power dissipation can be calculated by taking into account the voltage drop across the power switch ( $V_{IN}-V_{OUT}$ ) and the magnitude of the output current in active current-limit operation ( $I_{ACL}$ ):

$$PD = (V_{IN}-V_{OUT}) \times I_{ACL} \text{ or}$$
$$PD = (V_{IN} - (R_{LOAD} \times I_{ACL})) \times I_{ACL}$$

where:

PD = Power dissipation, in Watts (W)  
 $V_{IN}$  = Input Voltage, in Volts (V)  
 $R_{LOAD}$  = Load Resistance, in Ohms ( $\Omega$ )  
 $I_{ACL}$  = Output limited current, in Amps (A)  
 $V_{OUT} = R_{LOAD} \times I_{ACL}$

For more information on Dialog GreenFET3 integrated power switch features, please visit our [Documents](#) search page at our website and see [App Note "AN-1068 GreenFET3 Integrated Power Switch Basics"](#).

## SLG59M1713V

An Ultra-small, 4 mΩ, 2 A Integrated Power Switch with Multiple Protection Features

### Layout Guidelines:

1. The VDD pin needs a 0.1 μF (or larger) external capacitor to smooth pulses from the power supply. Locate this capacitor as close as possible to the SLG59M1713V's pin 1.
2. Since the VIN and VOUT pins dissipate most of the heat generated during high-load current operation, it is highly recommended to make power traces as short, direct, and wide as possible. A good practice is to make power traces with an absolute minimum widths of 15 mils (0.381 mm) per Ampere. A representative layout, shown in [Figure 19](#), illustrates proper techniques for heat to transfer as efficiently as possible out of the device;
3. To minimize the effects of parasitic trace inductance on normal operation, it is recommended to connect input C<sub>IN</sub> and output C<sub>LOAD</sub> low-ESR capacitors as close as possible to the SLG59M1713V's VIN and VOUT pins;
4. The GND pin should be connected to system analog or power ground plane.
5. 2 oz. copper is recommended for high current operation.

### SLG59M1713V Evaluation Board:

A GFET3 Evaluation Board for SLG59M1713V is designed according to the statements above and is illustrated on [Figure 19](#). Please note that evaluation board has D\_Sense and S\_Sense pads. They cannot carry high currents and dedicated only for RDS<sub>ON</sub> evaluation.

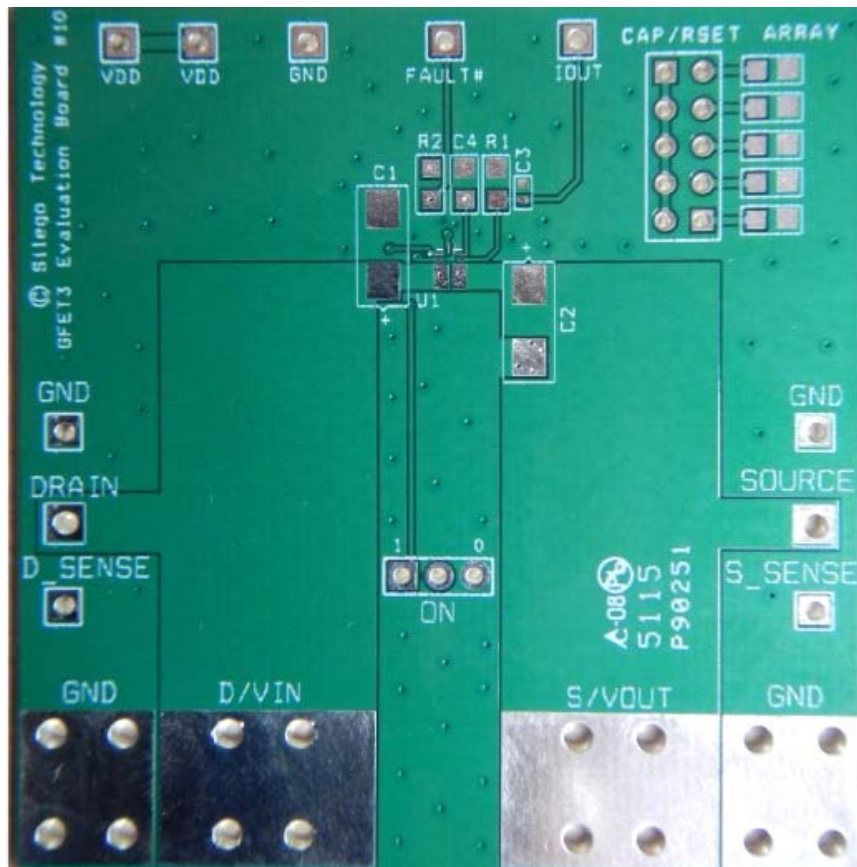

Figure 19. SLG59M1713V Evaluation Board

An Ultra-small, 4 mΩ, 2 A Integrated Power Switch with Multiple Protection Features

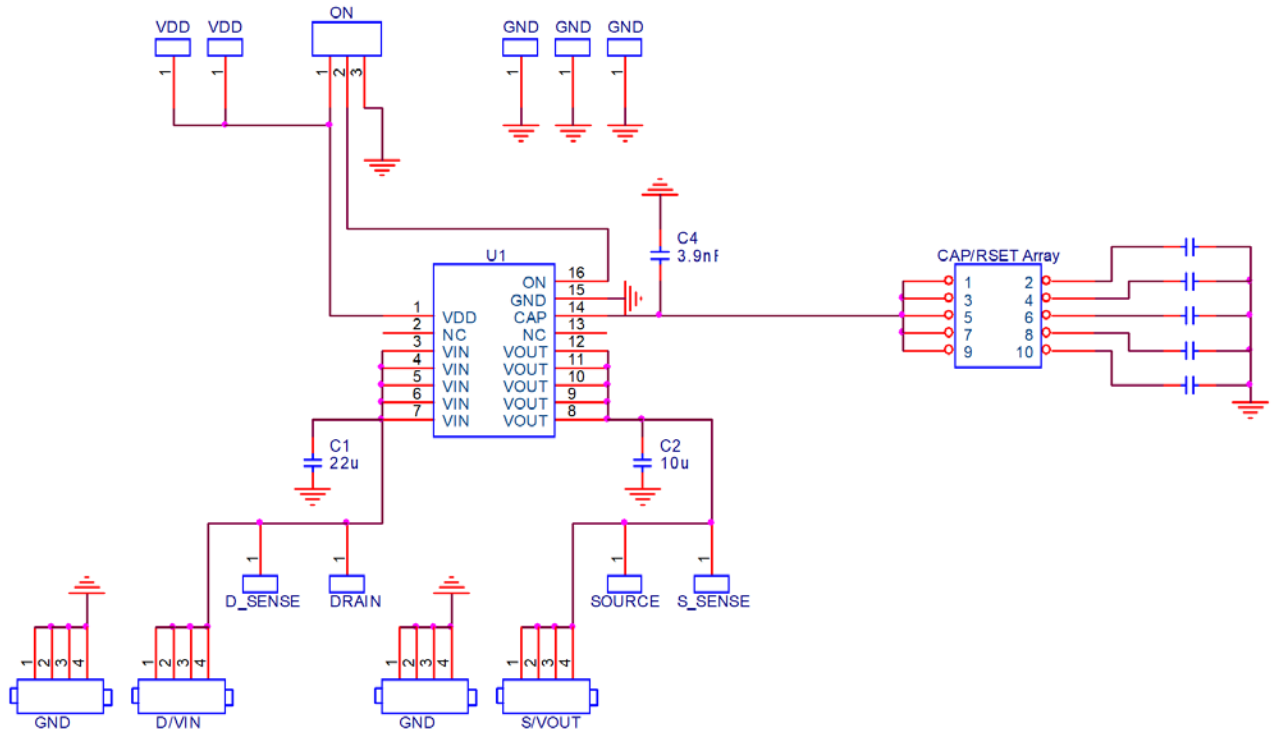

Figure 20. SLG59M1713V Evaluation Board Connection Circuit

Basic Test Setup and Connections

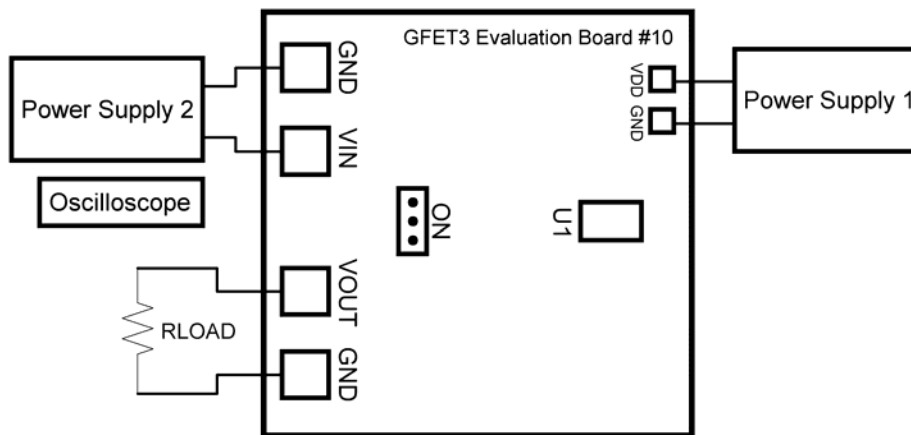

Figure 21. SLG59M1713V Evaluation Board Connection Circuit

EVB Configuration

1. Connect oscilloscope probes to D/VIN, S/VOUT, ON, etc.;
2. Turn on Power Supply 1 and set desired  $V_{DD}$  from 2.5 V...5.5 V range;
3. Turn on Power Supply 2 and set desired  $V_{IN}$  from 0.8 V... $V_{DD}$  range;
4. Toggle the ON signal High or Low to observe SLG59M1713V operation.



An Ultra-small, 4 mΩ, 2 A Integrated Power Switch  
with Multiple Protection Features

Package Top Marking System Definition

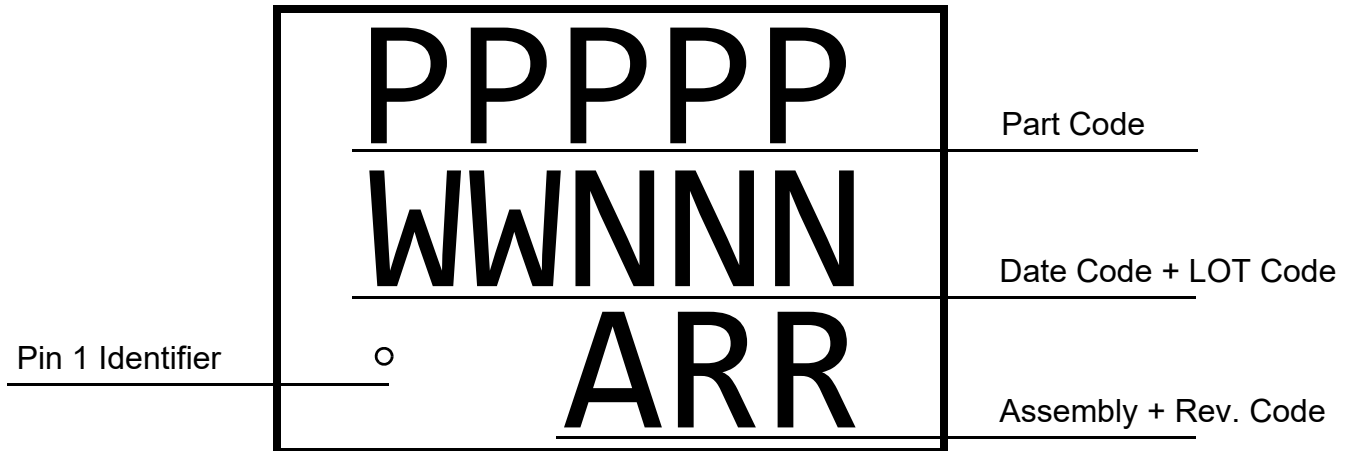

- PPPPP - Part ID Field
- WW - Date Code Field<sup>1</sup>
- NNN - Lot Traceability Code Field<sup>1</sup>
- A - Assembly Site Code Field<sup>2</sup>
- RR - Part Revision Code Field<sup>2</sup>

Note 1: Each character in code field can be alphanumeric A-Z and 0-9  
Note 2: Character in code field can be alphabetic A-Z

An Ultra-small, 4 mΩ, 2 A Integrated Power Switch with Multiple Protection Features

Package Drawing and Dimensions

16 Lead STQFN Package 1.6 mm x 2.5 mm (Fused Lead)

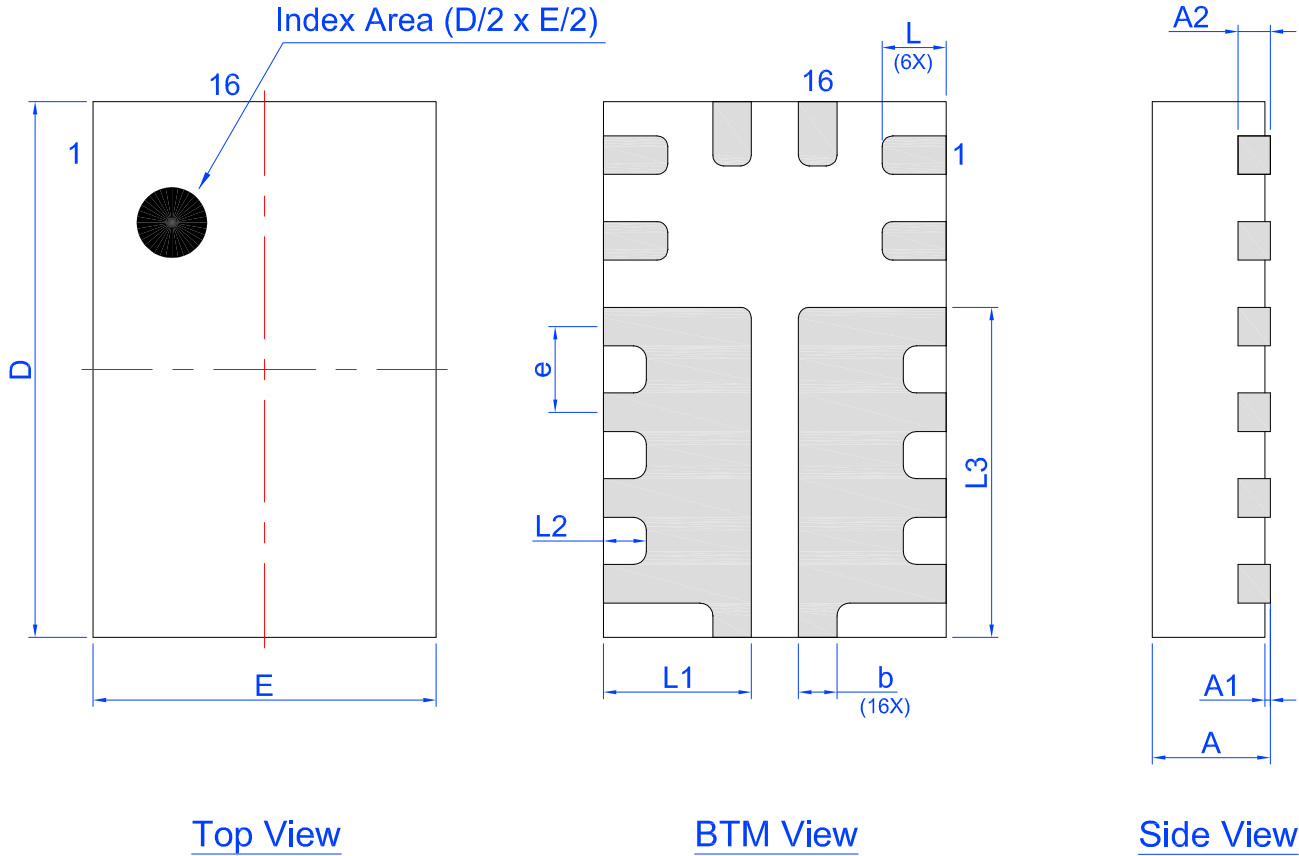

Unit: mm

Symbol	Min	Nom.	Max	Symbol	Min	Nom.	Max
A	0.50	0.55	0.60	D	2.45	2.50	2.55
A1	0.005	-	0.05	E	1.55	1.60	1.65
A2	0.10	0.15	0.20	L	0.25	0.30	0.35
b	0.13	0.18	0.23	L1	0.64	0.69	0.74
e	0.40 BSC			L2	0.15	0.20	0.25
				L3	1.49	1.54	1.59

# SLG59M1713V

An Ultra-small, 4 mΩ, 2 A Integrated Power Switch with Multiple Protection Features

## SLG59M1713V 16-pin STQFN PCB Landing Pattern

 Exposed Pad (PKG face down)
 
 Recommended Land Pattern (PKG face down)

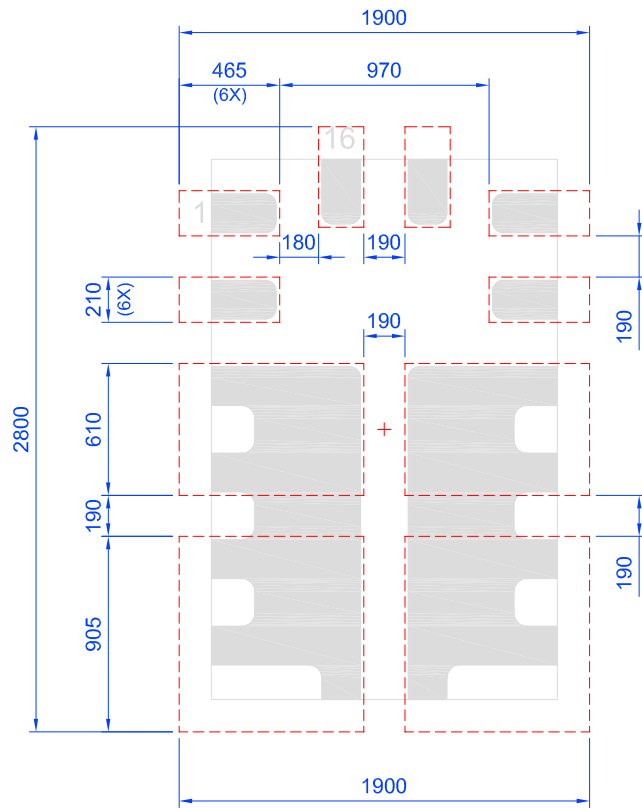
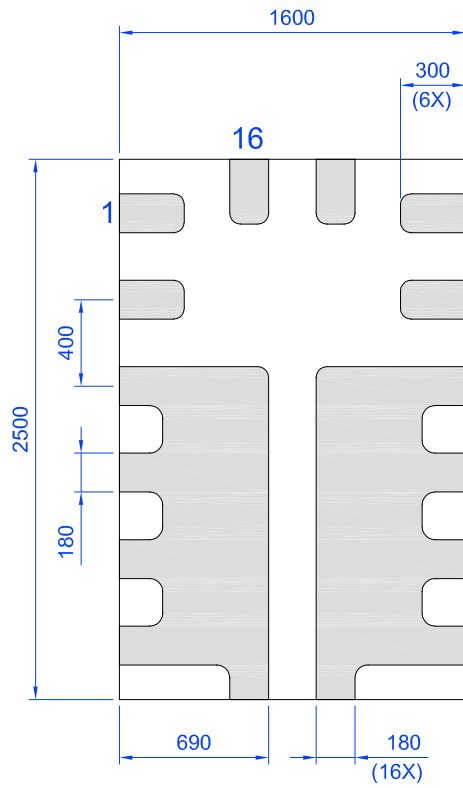

Unit: um

An Ultra-small, 4 mΩ, 2 A Integrated Power Switch with Multiple Protection Features

Tape and Reel Specifications

Package Type	# of Pins	Nominal Package Size [mm]	Max Units		Reel & Hub Size [mm]	Leader (min)		Trailer (min)		Tape Width [mm]	Part Pitch [mm]
			per Reel	per Box		Pockets	Length [mm]	Pockets	Length [mm]		
STQFN 16L 1.6x2.5mm 0.4P FCA Green	16	1.6x2.5x 0.55mm	3000	3000	178/60	100	400	100	400	8	4

Carrier Tape Drawing and Dimensions

Package Type	Pocket BTM Length	Pocket BTM Width	Pocket Depth	Index Hole Pitch	Pocket Pitch	Index Hole Diameter	Index Hole to Tape Edge	Index Hole to Pocket Center	Tape Width
	A0	B0	K0	P0	P1	D0	E	F	W
STQFN 16L 1.6x2.5mm 0.4P FCA Green	1.8	2.8	0.7	4	4	1.55	1.75	3.5	8

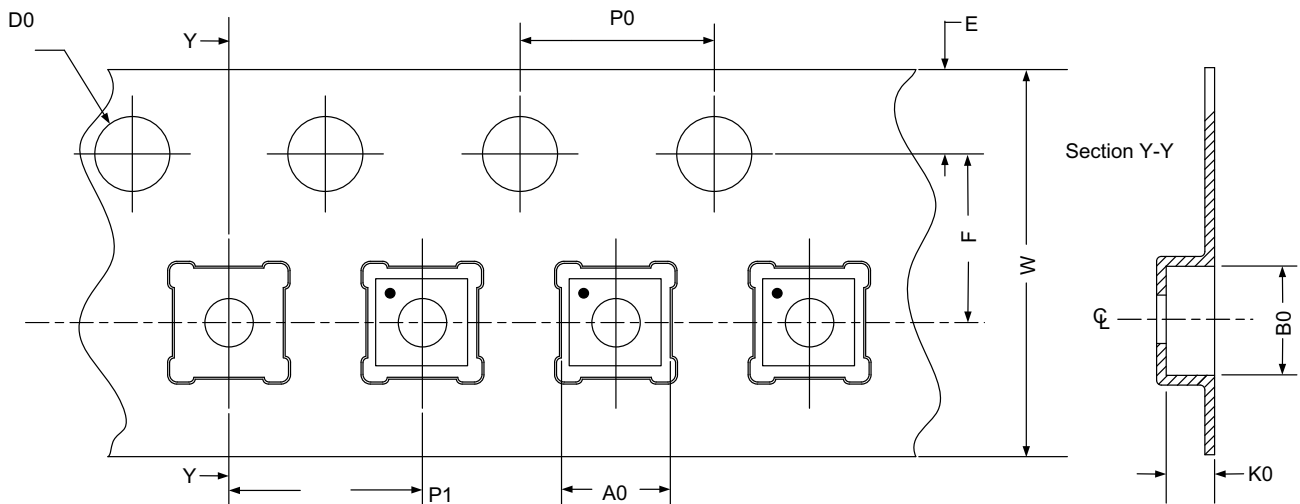

Refer to EIA-481 specification

Recommended Reflow Soldering Profile

Please see IPC/JEDEC J-STD-020: latest revision for reflow profile based on package volume of 2.2 mm<sup>3</sup> (nominal). More information can be found at [www.jedec.org](http://www.jedec.org).

---

An Ultra-small, 4 mΩ, 2 A Integrated Power Switch  
with Multiple Protection Features

**Revision History**

Date	Version	Change
4/16/2019	1.03	Updated Charts Added Scopeshots
4/11/2019	1.02	Updated Timing Diagrams for clarification
4/5/2019	1.01	Updated Style and formatting Added Layout Guidelines Fixed typos
2/23/2017	1.00	Production Release

# Mouser Electronics

Authorized Distributor

Click to View Pricing, Inventory, Delivery & Lifecycle Information:

[Dialog Semiconductor:](#)

[SLG59M1713V](#)