

R5H30313XB08 for USB Type-C™ Authentication



Renesas Microcomputer



R01DS0314EJ0110

Rev.1.10

Feb 28, 2019

Overview

This LSI is a microcomputer which offers the authentication function for PD products to USB Power Delivery Controller R9A02G011. The authentication function which offered by the LSI is based on the Universal Serial Bus Type-C™ Authentication Specification Revision 1.0.

Applications

USB Type-C™ Authentication supported devices (AC Adapter, Power outlet, USB PD Hub, PC, Tablet, Smartphone, Docking Station, PC Peripheral Device (Monitor, Printer, Router, External HDD), Consumer Electronics (DTV, STB, Home Gateway), USB Type-C™ Cable etc.)

Table 1 Features

Classification	Description
Authentication function	<ul style="list-style-type: none"> Based on the Universal Serial Bus Type-C™ Authentication Specification Revision 1.0 Works as Authentication Initiator^{Note 1} or Authentication Responder^{Note 1}. And private keys, Certificate Chain^{Note 1}, Root Certificate^{Note 1} and Certificate Chain digests are managed. Authentication Initiator caches Authentication Responder's Certificate Chains (cache size: 16 Certificate Chains).
Hardware Security	<ul style="list-style-type: none"> Security error detecting functions Current control functions
On-chip memory	<ul style="list-style-type: none"> EEPROM Private keys, Certificate Chain, Root Certificate and Certificate Chain digests used for authentication are stored. Data retention time: 10 years
Power-down modes	<ul style="list-style-type: none"> Power-Down States is entered by a request of R9A02G011
CPU operating clock	<ul style="list-style-type: none"> Internal clock
Communication interface	<ul style="list-style-type: none"> I²C bus interface is used.
Power-on reset circuit	<ul style="list-style-type: none"> Incorporated
Power supply	<ul style="list-style-type: none"> Single-voltage power supply 1.8 V to 3.6 V
Operating peripheral temperature (°C)	<ul style="list-style-type: none"> -40°C to +90°C

Notes: 1. Unique names in this paragraph are defined in the Universal Serial Bus Type-C™ Authentication Specification Revision 1.0.

Ordering Information

Table 2 is an ordering information.

Table 2 Ordering Information

Part No.	Application	Package
R5H30313XB08NAxx ^{Note}	Universal Serial Bus Type-C™ Authentication	UQFN0404-20

Note xx is determined by internal code for each customer's product. Please contact a Renesas Sales Representative or Distributor in your area.

Pin Assignment and Functions

Pin Assignment

Figure 1 shows the pin arrangement of this LSI.

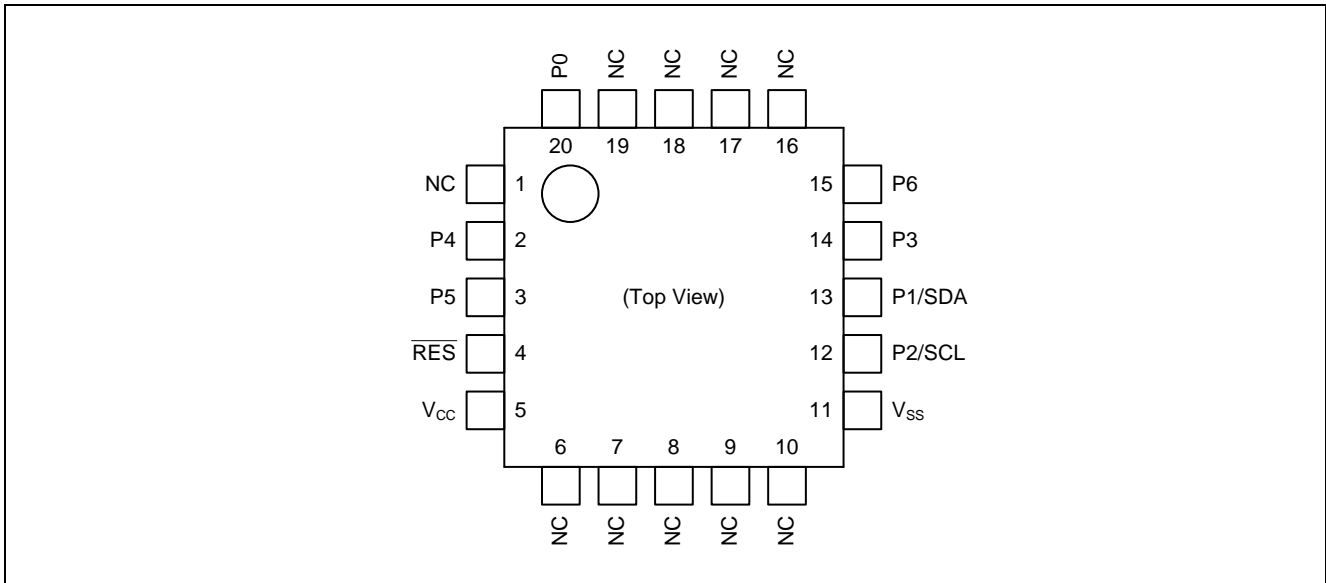

Figure 1 Pin Assignment

Pin Functions

Table 3 lists the pin functions of this LSI.

Table 3 Pin Functions

Pin No.	Pin Name	I/O	Function
2	P4	Input	Unused pin. Connect this pin to V _{SS} via a pull-down resistor.
3	P5	Input	Unused pin. Connect this pin to V _{SS} via a pull-down resistor.
4	RES	Input	Reset pin. Low-level input resets the chip.
5	V _{CC}	Input	Power supply. Connected to the power supply of the system.
11	V _{SS}	Input	Ground. Connected to the power supply (0 V) of the system.
12	P2/SCL	I/O	Clock input/output pin for the I ² C bus interface. It's also the input pin from which software standby mode and deep software standby mode is canceled.
13	P1/SDA	I/O	Data input/output pin for the I ² C bus interface. It's also the input pin from which software standby mode and deep software standby mode is canceled.
14	P3	Input	Unused pin. Connect this pin to V _{SS} via a pull-down resistor.
15	P6	Output	Unused pin. Leave this pin open.
20	P0	Input	Unused pin. Connect this pin to V _{SS} via a pull-down resistor.

Absolute Maximum Ratings

Table 4 Absolute Maximum Ratings

Item		Symbol	Rating	Unit
Power supply voltage	V_{CC}	V_{CC}	-0.3 to +7.0	V
Input voltage	V_{in}	\overline{RES} , P1/SDA, P2/SCL	-0.3 to $V_{CC} + 0.3$	V
Operating temperature	T_{opr}		-40 to +90	°C
Storage temperature	T_{stg}		-55 to +90	°C

Note: Permanent damage may occur to the chip if maximum ratings are exceeded. Normal operation should be under the recommended operating conditions. Exceeding these conditions could affect the reliability of the chip.

DC Characteristics

Table 5 DC Characteristics

Conditions: $V_{CC} = 1.8\text{ V to }3.6\text{ V}$, $V_{SS} = 0\text{ V}$, $T_a = -40^\circ\text{C to }+90^\circ\text{C}$, unless otherwise specified.

Item	Sym.	Test Conditions	Min.	Typ.	Max.	Unit	
Input high voltage	$\overline{\text{RES}}$, P1/SDA, P2/SCL	V_{IH}	$V_{CC} = 1.8\text{ to }2.2\text{ V}$	$V_{CC} \times 0.85$	—	$V_{CC} + 0.3$	V
			$V_{CC} = 2.2\text{ to }3.6\text{ V}$	$V_{CC} \times 0.7$	—	$V_{CC} + 0.3$	V
Input low voltage	$\overline{\text{RES}}$, P1/SDA, P2/SCL	V_{IL}	$V_{CC} = 1.8\text{ to }2.2\text{ V}$	-0.3	—	0.2	V
			$V_{CC} = 2.2\text{ to }3.6\text{ V}$	-0.3	—	$V_{CC} \times 0.2$	V
Output low voltage	P1/SDA, P2/SCL	V_{OL}	$I_{OL} = 1\text{ mA}$	0	—	0.4	V
Input leakage current	P1/SDA, P2/SCL	$ I_{in} $	$V_{in} = 0.5\text{ to }V_{CC} - 0.5\text{ V}$	—	—	10	μA
Input pull-up MOSFET current	$\overline{\text{RES}}$ ^{Note 1} P1/SDA, P2/SCL ^{Note 3}	$-I_p$	$V_{in} = 0\text{ V}$	—	—	150	μA
Supply current	Authentication operation	I_{CC}	Note 2	—	—	15	mA
	With software standby mode ^{Note 1}			—	—	200	μA
	With deep software standby mode ^{Note 1 Note 3}			—	5	10	μA
Pin capacitance		C_p	$V_{in} = 0\text{ V}$, $f = 1\text{ MHz}$, $T_a = 25^\circ\text{C}$	—	—	15	pF

- Notes: 1. A pull-up MOSFET is connected to the $\overline{\text{RES}}$ pin, and thus the pull-up function is always enabled even in deep software standby mode.
 2. Supply current is determined assuming that all the input pins are set to $V_{IH} = V_{CC}$ or $V_{IL} = 0\text{ V}$, all the output pins are unloaded, and pull-up resistors are disabled.
 3. A pull-up MOSFET is connected to the P1/SDA and P2/SCL pins, and thus the pull-up function is enabled in deep software standby mode.

AC Characteristics

Table 6 AC Characteristics

Conditions: $V_{CC} = 1.8\text{ V to }3.6\text{ V}$, $V_{SS} = 0\text{ V}$, $T_a = -40^\circ\text{C to }+90^\circ\text{C}$, unless otherwise specified.

Item	Sym.	Test Conditions	Min.	Typ.	Max.	Unit
RES fall time	t_{rf}	Figure 2	—	—	400 ^{Note 1}	μs
RES rise time	t_{rr}	Figure 2	—	—	400 ^{Note 1}	μs

- Notes: 1. It is assumed that there is no noise on the RES pin, and the rise and fall of RES are straightforward.

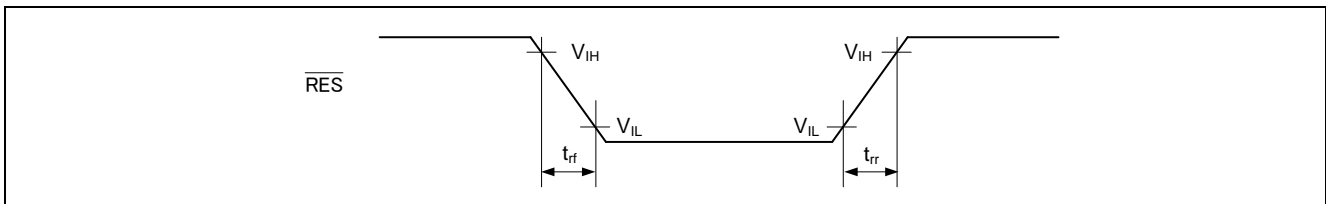

Figure 2 RES Input Waveform

Reset Circuit Characteristics

Table 7 Reset Circuit Characteristics

Conditions: $V_{CC} = 1.8\text{ V to }3.6\text{ V}$, $V_{SS} = 0\text{ V}$, $T_a = -40^\circ\text{C to }+90^\circ\text{C}$, unless otherwise specified.

Item	Sym.	Test Conditions	Min.	Typ.	Max.	Unit
Power-on reset effective voltage	V_{POR1}	Figure 3	—	—	0.4	V
Power-on reset release voltage rise time	t_{PWON1}	Figure 3	—	—	500	μs
		$t_{POR1} \geq 500\mu\text{s}$ Note 1				
Power-on reset release time	t_{PRST}	Figure 3	—	—	500	μs

Notes: 1. t_{POR1} is the time necessary to enable the power-on reset by keeping the external power supply V_{CC} to lower than the effective voltage (V_{POR1}). The external power supply V_{CC} should be stable. The LSI may be reset by the rapid change of V_{CC} .

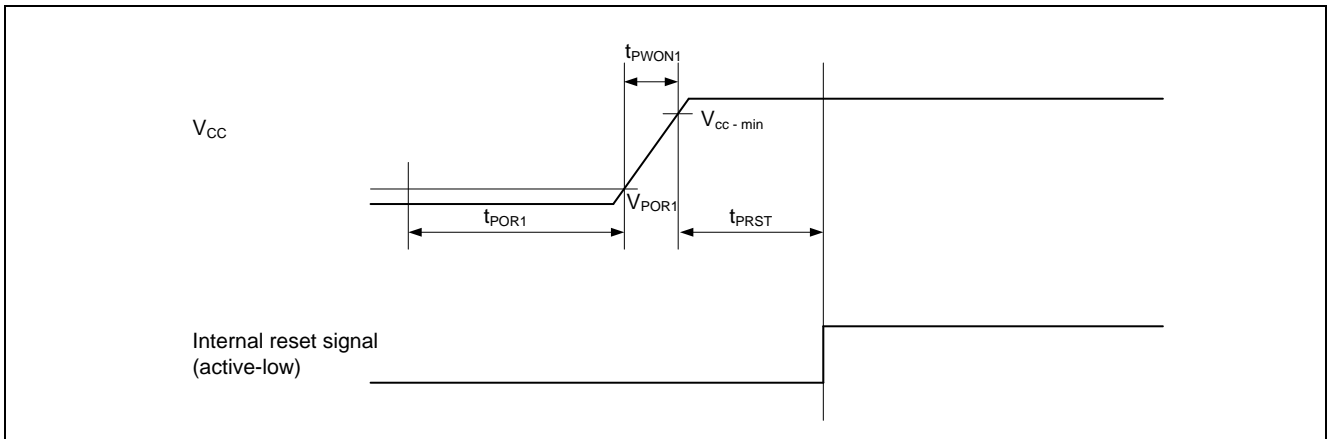
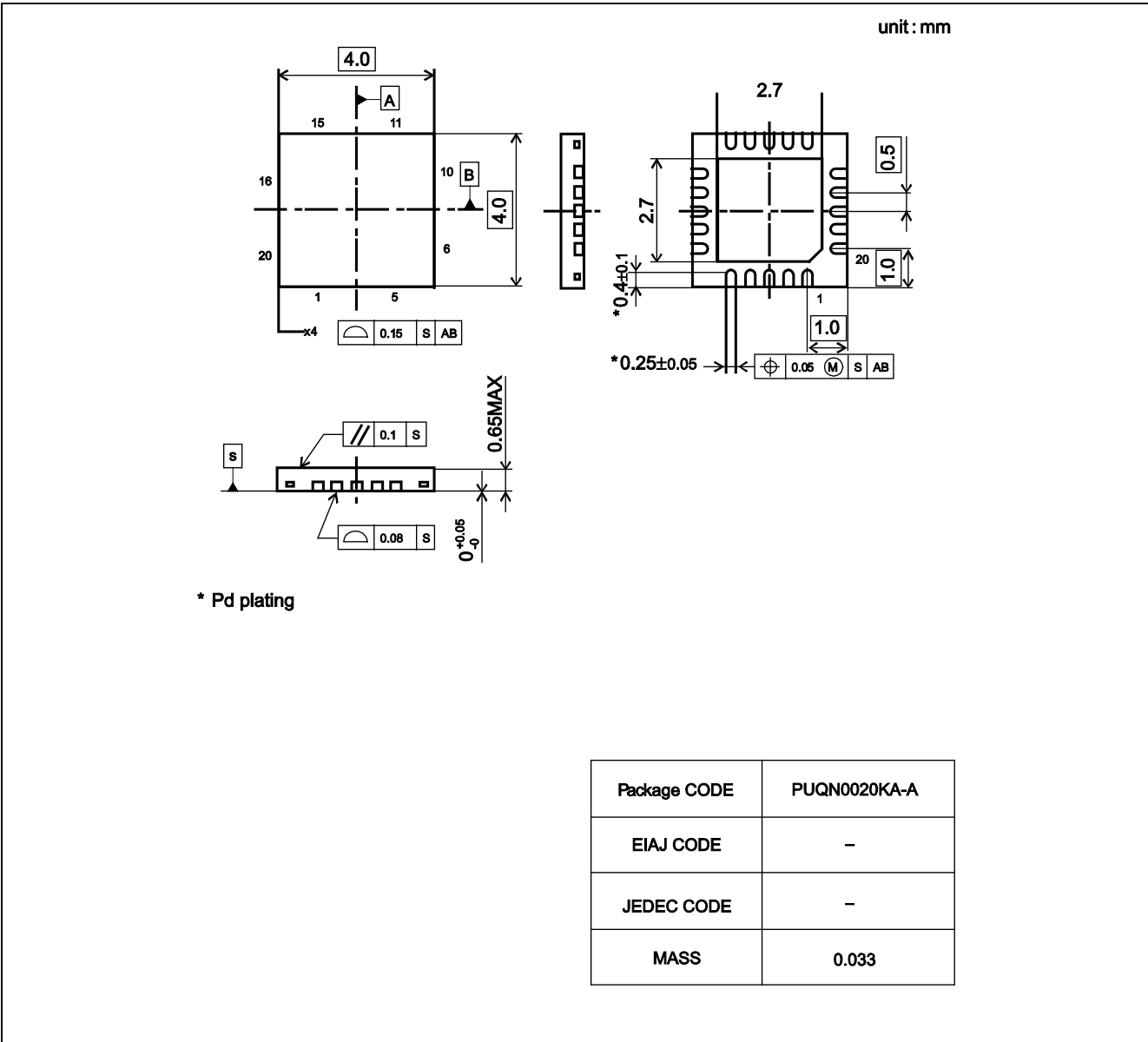

Figure 3 Power-On Reset Timing

Notes on Noise

Notes: 1. Inserting a Bypass Capacitor between V_{CC} and V_{SS} Pins as a Countermeasure against Noise and Latch-up
Connect a bypass capacitor (with a value of about 0.1 μF) using the shortest and thickest wiring runs possible.

Package Dimensions



Revision History	R5H30313XB08 for USB Type-C™ Authentication Data Sheet
-------------------------	---

Rev.	Date	Description	
		Page	Summary
1.00	Apr 17, 2017	—	First edition issued
1.10	Feb 28, 2019	2	Updated Ordering Information

All trademarks and registered trademarks are the property of their respective owners.

General Precautions in the Handling of Microprocessing Unit and Microcontroller Unit Products

The following usage notes are applicable to all Microprocessing unit and Microcontroller unit products from Renesas. For detailed usage notes on the products covered by this document, refer to the relevant sections of the document as well as any technical updates that have been issued for the products.

1. Precaution against Electrostatic Discharge (ESD)

A strong electrical field, when exposed to a CMOS device, can cause destruction of the gate oxide and ultimately degrade the device operation. Steps must be taken to stop the generation of static electricity as much as possible, and quickly dissipate it when it occurs. Environmental control must be adequate. When it is dry, a humidifier should be used. This is recommended to avoid using insulators that can easily build up static electricity.

Semiconductor devices must be stored and transported in an anti-static container, static shielding bag or conductive material. All test and measurement tools including work benches and floors must be grounded. The operator must also be grounded using a wrist strap. Semiconductor devices must not be touched with bare hands. Similar precautions must be taken for printed circuit boards with mounted semiconductor devices.

2. Processing at power-on

The state of the product is undefined at the time when power is supplied. The states of internal circuits in the LSI are indeterminate and the states of register settings and pins are undefined at the time when power is supplied. In a finished product where the reset signal is applied to the external reset pin, the states of pins are not guaranteed from the time when power is supplied until the reset process is completed. In a similar way, the states of pins in a product that is reset by an on-chip power-on reset function are not guaranteed from the time when power is supplied until the power reaches the level at which resetting is specified.

3. Input of signal during power-off state

Do not input signals or an I/O pull-up power supply while the device is powered off. The current injection that results from input of such a signal or I/O pull-up power supply may cause malfunction and the abnormal current that passes in the device at this time may cause degradation of internal elements. Follow the guideline for input signal during power-off state as described in your product documentation.

4. Handling of unused pins

Handle unused pins in accordance with the directions given under handling of unused pins in the manual. The input pins of CMOS products are generally in the high-impedance state. In operation with an unused pin in the open-circuit state, extra electromagnetic noise is induced in the vicinity of the LSI, an associated shoot-through current flows internally, and malfunctions occur due to the false recognition of the pin state as an input signal become possible.

5. Clock signals

After applying a reset, only release the reset line after the operating clock signal becomes stable. When switching the clock signal during program execution, wait until the target clock signal is stabilized. When the clock signal is generated with an external resonator or from an external oscillator during a reset, ensure that the reset line is only released after full stabilization of the clock signal. Additionally, when switching to a clock signal produced with an external resonator or by an external oscillator while program execution is in progress, wait until the target clock signal is stable.

6. Voltage application waveform at input pin

Waveform distortion due to input noise or a reflected wave may cause malfunction. If the input of the CMOS device stays in the area between V_{IL} (Max.) and V_{IH} (Min.) due to noise, for example, the device may malfunction. Take care to prevent chattering noise from entering the device when the input level is fixed, and also in the transition period when the input level passes through the area between V_{IL} (Max.) and V_{IH} (Min.).

7. Prohibition of access to reserved addresses

Access to reserved addresses is prohibited. The reserved addresses are provided for possible future expansion of functions. Do not access these addresses as the correct operation of the LSI is not guaranteed.

8. Differences between products

Before changing from one product to another, for example to a product with a different part number, confirm that the change will not lead to problems. The characteristics of a microprocessing unit or microcontroller unit products in the same group but having a different part number might differ in terms of internal memory capacity, layout pattern, and other factors, which can affect the ranges of electrical characteristics, such as characteristic values, operating margins, immunity to noise, and amount of radiated noise. When changing to a product with a different part number, implement a system-evaluation test for the given product.

Notice

1. Descriptions of circuits, software and other related information in this document are provided only to illustrate the operation of semiconductor products and application examples. You are fully responsible for the incorporation or any other use of the circuits, software, and information in the design of your product or system. Renesas Electronics disclaims any and all liability for any losses and damages incurred by you or third parties arising from the use of these circuits, software, or information.
2. Renesas Electronics hereby expressly disclaims any warranties against and liability for infringement or any other claims involving patents, copyrights, or other intellectual property rights of third parties, by or arising from the use of Renesas Electronics products or technical information described in this document, including but not limited to, the product data, drawings, charts, programs, algorithms, and application examples.
3. No license, express, implied or otherwise, is granted hereby under any patents, copyrights or other intellectual property rights of Renesas Electronics or others.
4. You shall not alter, modify, copy, or reverse engineer any Renesas Electronics product, whether in whole or in part. Renesas Electronics disclaims any and all liability for any losses or damages incurred by you or third parties arising from such alteration, modification, copying or reverse engineering.
5. Renesas Electronics products are classified according to the following two quality grades: "Standard" and "High Quality". The intended applications for each Renesas Electronics product depends on the product's quality grade, as indicated below.
"Standard": Computers; office equipment; communications equipment; test and measurement equipment; audio and visual equipment; home electronic appliances; machine tools; personal electronic equipment; industrial robots; etc.
"High Quality": Transportation equipment (automobiles, trains, ships, etc.); traffic control (traffic lights); large-scale communication equipment; key financial terminal systems; safety control equipment; etc.
Unless expressly designated as a high reliability product or a product for harsh environments in a Renesas Electronics data sheet or other Renesas Electronics document, Renesas Electronics products are not intended or authorized for use in products or systems that may pose a direct threat to human life or bodily injury (artificial life support devices or systems; surgical implantations; etc.), or may cause serious property damage (space system; undersea repeaters; nuclear power control systems; aircraft control systems; key plant systems; military equipment; etc.). Renesas Electronics disclaims any and all liability for any damages or losses incurred by you or any third parties arising from the use of any Renesas Electronics product that is inconsistent with any Renesas Electronics data sheet, user's manual or other Renesas Electronics document.
6. When using Renesas Electronics products, refer to the latest product information (data sheets, user's manuals, application notes, "General Notes for Handling and Using Semiconductor Devices" in the reliability handbook, etc.), and ensure that usage conditions are within the ranges specified by Renesas Electronics with respect to maximum ratings, operating power supply voltage range, heat dissipation characteristics, installation, etc. Renesas Electronics disclaims any and all liability for any malfunctions, failure or accident arising out of the use of Renesas Electronics products outside of such specified ranges.
7. Although Renesas Electronics endeavors to improve the quality and reliability of Renesas Electronics products, semiconductor products have specific characteristics, such as the occurrence of failure at a certain rate and malfunctions under certain use conditions. Unless designated as a high reliability product or a product for harsh environments in a Renesas Electronics data sheet or other Renesas Electronics document, Renesas Electronics products are not subject to radiation resistance design. You are responsible for implementing safety measures to guard against the possibility of bodily injury, injury or damage caused by fire, and/or danger to the public in the event of a failure or malfunction of Renesas Electronics products, such as safety design for hardware and software, including but not limited to redundancy, fire control and malfunction prevention, appropriate treatment for aging degradation or any other appropriate measures. Because the evaluation of microcomputer software alone is very difficult and impractical, you are responsible for evaluating the safety of the final products or systems manufactured by you.
8. Please contact a Renesas Electronics sales office for details as to environmental matters such as the environmental compatibility of each Renesas Electronics product. You are responsible for carefully and sufficiently investigating applicable laws and regulations that regulate the inclusion or use of controlled substances, including without limitation, the EU RoHS Directive, and using Renesas Electronics products in compliance with all these applicable laws and regulations. Renesas Electronics disclaims any and all liability for damages or losses occurring as a result of your noncompliance with applicable laws and regulations.
9. Renesas Electronics products and technologies shall not be used for or incorporated into any products or systems whose manufacture, use, or sale is prohibited under any applicable domestic or foreign laws or regulations. You shall comply with any applicable export control laws and regulations promulgated and administered by the governments of any countries asserting jurisdiction over the parties or transactions.
10. It is the responsibility of the buyer or distributor of Renesas Electronics products, or any other party who distributes, disposes of, or otherwise sells or transfers the product to a third party, to notify such third party in advance of the contents and conditions set forth in this document.
11. This document shall not be reprinted, reproduced or duplicated in any form, in whole or in part, without prior written consent of Renesas Electronics.
12. Please contact a Renesas Electronics sales office if you have any questions regarding the information contained in this document or Renesas Electronics products.
(Note 1) "Renesas Electronics" as used in this document means Renesas Electronics Corporation and also includes its directly or indirectly controlled subsidiaries.
(Note 2) "Renesas Electronics product(s)" means any product developed or manufactured by or for Renesas Electronics.

(Rev.4.0-1 November 2017)



SALES OFFICES

Renesas Electronics Corporation

<http://www.renesas.com>

Refer to "<http://www.renesas.com/>" for the latest and detailed information.

Renesas Electronics Corporation

TOYOSU FORESIA, 3-2-24 Toyosu, Koto-ku, Tokyo 135-0061, Japan

Renesas Electronics America Inc.

1001 Murphy Ranch Road, Milpitas, CA 95035, U.S.A.
Tel: +1-408-432-8888, Fax: +1-408-434-5351

Renesas Electronics Canada Limited

9251 Yonge Street, Suite 8309 Richmond Hill, Ontario Canada L4C 9T3
Tel: +1-905-237-2004

Renesas Electronics Europe Limited

Dukes Meadow, Millboard Road, Bourne End, Buckinghamshire, SL8 5FH, U.K
Tel: +44-1628-651-700

Renesas Electronics Europe GmbH

Arcadiastrasse 10, 40472 Düsseldorf, Germany
Tel: +49-211-6503-0, Fax: +49-211-6503-1327

Renesas Electronics (China) Co., Ltd.

Room 1709 Quantum Plaza, No.27 ZhichunLu, Haidian District, Beijing, 100191 P. R. China
Tel: +86-10-8235-1155, Fax: +86-10-8235-7679

Renesas Electronics (Shanghai) Co., Ltd.

Unit 301, Tower A, Central Towers, 555 Langao Road, Putuo District, Shanghai, 200333 P. R. China
Tel: +86-21-2226-0888, Fax: +86-21-2226-0999

Renesas Electronics Hong Kong Limited

Unit 1601-1611, 16/F., Tower 2, Grand Century Place, 193 Prince Edward Road West, Mongkok, Kowloon, Hong Kong
Tel: +852-2265-6688, Fax: +852 2886-9022

Renesas Electronics Taiwan Co., Ltd.

13F, No. 363, Fu Shing North Road, Taipei 10543, Taiwan
Tel: +886-2-8175-9600, Fax: +886 2-8175-9670

Renesas Electronics Singapore Pte. Ltd.

80 Bendemeer Road, Unit #06-02 Hyflux Innovation Centre, Singapore 339949
Tel: +65-6213-0200, Fax: +65-6213-0300

Renesas Electronics Malaysia Sdn.Bhd.

Unit 1207, Block B, Menara Amcorp, Amcorp Trade Centre, No. 18, Jln Persiaran Barat, 46050 Petaling Jaya, Selangor Darul Ehsan, Malaysia
Tel: +60-3-7955-9390, Fax: +60-3-7955-9510

Renesas Electronics India Pvt. Ltd.

No.777C, 100 Feet Road, HAL 2nd Stage, Indiranagar, Bangalore 560 038, India
Tel: +91-80-67208700, Fax: +91-80-67208777

Renesas Electronics Korea Co., Ltd.

17F, KAMCO Yangjae Tower, 262, Gangnam-daero, Gangnam-gu, Seoul, 06265 Korea
Tel: +82-2-558-3737, Fax: +82-2-558-5338

Mouser Electronics

Authorized Distributor

Click to View Pricing, Inventory, Delivery & Lifecycle Information:

[Renesas Electronics:](#)

[R9A02G011GNP#AC0](#)