

## General Description

The 83905 is a low skew, 1-to-6 LVCMOS / LVTTTL Fanout Buffer. The low impedance LVCMOS/LVTTTL outputs are designed to drive 50Ω series or parallel terminated transmission lines. The effective fanout can be increased from 6 to 12 by utilizing the ability of the outputs to drive two series terminated lines.

The 83905 is characterized at full 3.3V, 2.5V, and 1.8V, mixed 3.3V/2.5V, 3.3V/1.8V and 2.5V/1.8V output operating supply mode. Guaranteed output and part-to-part skew characteristics along with the 1.8V output capabilities makes the 83905 ideal for high performance, single ended applications that also require a limited output voltage.

## Pin Assignments

**83905**  
**20-Lead VFQFN**  
4mm x 4mm x 0.925mm  
package body  
**K Package**  
Top View

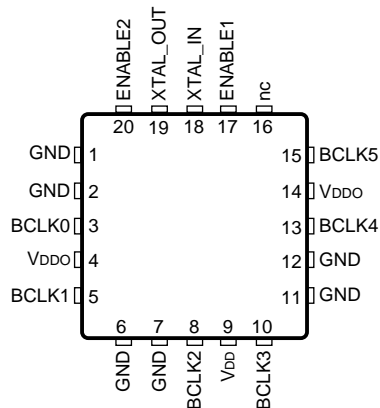

**83905**  
**16-Lead SOIC, 150 Mil**  
3.9mm x 9.9mm x 1.38mm  
package body  
**M Package**  
Top View

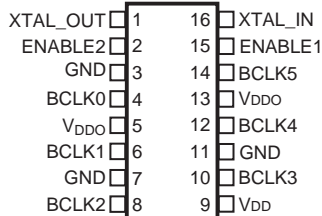

**16-Lead TSSOP**  
4.4mm x 5.0mm x 0.925mm  
package body  
**G Package**  
Top View

## Features

- Six LVCMOS / LVTTTL outputs
- Outputs able to drive 12 series terminated lines
- Crystal Oscillator Interface
- Crystal input frequency range: 10MHz to 40MHz
- Output skew: 80ps (maximum)
- RMS phase jitter @ 25MHz, (100Hz – 1MHz): 0.26ps (typical),  $V_{DD} = V_{DD0} = 2.5V$

Offset	Noise Power
100Hz	-129.7 dBc/Hz
1kHz	-144.4 dBc/Hz
10kHz	-147.3 dBc/Hz
100kHz	-157.3 dBc/Hz

- 5V tolerant enable inputs
- Synchronous output enables
- Operating power supply modes:  
Full 3.3V, 2.5V, 1.8V  
Mixed 3.3V core/2.5V output operating supply  
Mixed 3.3V core/1.8V output operating supply  
Mixed 2.5V core/1.8V output operating supply
- 0°C to 70°C ambient operating temperature
- Lead-free (RoHS 6) packaging

## Block Diagram

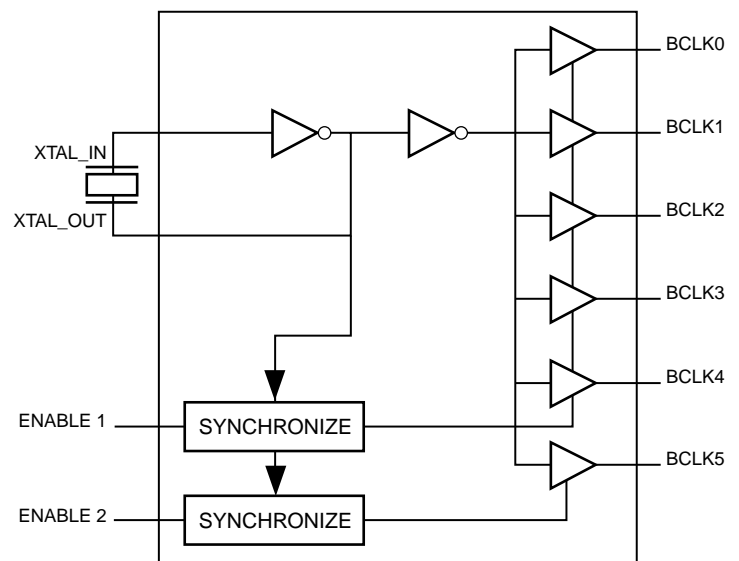

## Pin Descriptions and Characteristics

**Table 1. Pin Descriptions**

Name	Type	Description
XTAL_OUT	Output	Crystal oscillator interface. XTAL_OUT is the output.
XTAL_IN	Input	Crystal oscillator interface. XTAL_IN is the input.
ENABLE1, ENABLE2	Input	Clock enable. LVCMOS/LVTTL interface levels. See Table 3.
BCLK0, BCLK1, BCLK2, BCLK3, BCLK4, BCLK5	Output	Clock outputs. LVCMOS/LVTTL interface levels.
GND	Power	Power supply ground.
V <sub>DD</sub>	Power	Power supply pin.
V <sub>DDO</sub>	Power	Output supply pin.
nc	Unused	No connect.

**Table 2. Pin Characteristics**

Symbol	Parameter	Test Conditions	Minimum	Typical	Maximum	Units
C <sub>IN</sub>	Input Capacitance			4		pF
C <sub>PD</sub>	Power Dissipation Capacitance (per output)	V <sub>DDO</sub> = 3.465V			19	pF
		V <sub>DDO</sub> = 2.625V			18	pF
		V <sub>DDO</sub> = 2.0V			16	pF
R <sub>OUT</sub>	Output Impedance	V <sub>DDO</sub> = 3.3V ± 5%		7		Ω
		V <sub>DDO</sub> = 2.5V ± 5%		7		Ω
		V <sub>DDO</sub> = 1.8V ± 0.2V		10		Ω

## Function Table

**Table 3. Clock Enable Function Table**

Control Inputs		Outputs	
ENABLE 1	ENABLE2	BCLK[0:4]	BCLK5
0	0	LOW	LOW
0	1	LOW	Toggling
1	0	Toggling	LOW
1	1	Toggling	Toggling

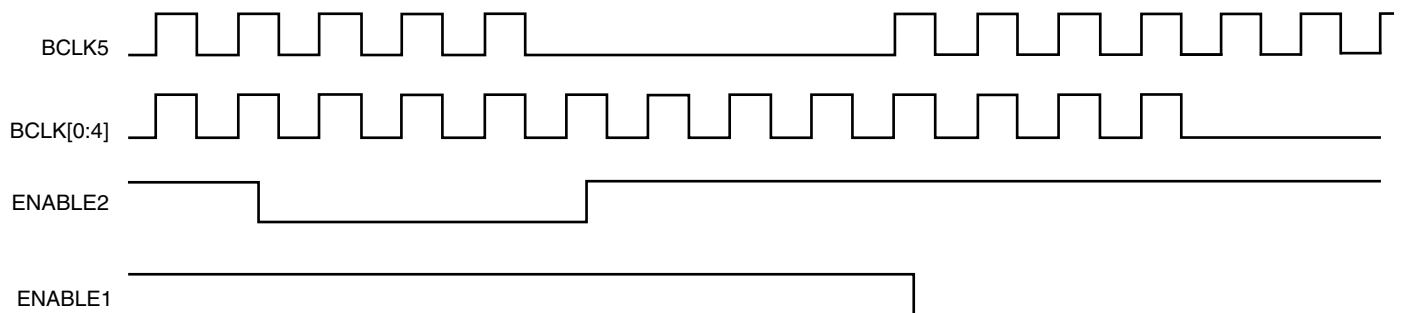

**Figure 1. Enable Timing Diagram**

## Absolute Maximum Ratings

NOTE: Stresses beyond those listed under *Absolute Maximum Ratings* may cause permanent damage to the device. These ratings are stress specifications only. Functional operation of product at these conditions or any conditions beyond those listed in the *DC Characteristics* or *AC Characteristics* is not implied. Exposure to absolute maximum rating conditions for extended periods may affect product reliability.

Item	Rating
Supply Voltage, $V_{DD}$	4.6V
Inputs, $V_I$	-0.5V to $V_{DD} + 0.5V$
Outputs, $V_O$	-0.5V to $V_{DDO} + 0.5V$
Package Thermal Impedance, $\theta_{JA}$ 16-Lead SOIC package 16-Lead TSSOP package 20-Lead VFQFN package	78.8°C/W (0 mps) 100.3°C/W (0 mps) 57.5°C/W (0 mps)
Storage Temperature, $T_{STG}$	-65°C to 150°C

## DC Electrical Characteristics

**Table 4A. Power Supply DC Characteristics,  $V_{DD} = V_{DDO} = 3.3V \pm 5\%$ ,  $T_A = 0^\circ C$  to  $70^\circ C$**

Symbol	Parameter	Test Conditions	Minimum	Typical	Maximum	Units
$V_{DD}$	Power Supply Voltage		3.135	3.3	3.465	V
$V_{DDO}$	Output Supply Voltage		3.135	3.3	3.465	V
$I_{DD}$	Power Supply Current	ENABLE [1:2] = 00			10	mA
$I_{DDO}$	Output Supply Current	ENABLE [1:2] = 00			5	mA

**Table 4B. Power Supply DC Characteristics,  $V_{DD} = V_{DDO} = 2.5V \pm 5\%$ ,  $T_A = 0^\circ C$  to  $70^\circ C$**

Symbol	Parameter	Test Conditions	Minimum	Typical	Maximum	Units
$V_{DD}$	Power Supply Voltage		2.375	2.5	2.625	V
$V_{DDO}$	Output Supply Voltage		2.375	2.5	2.625	V
$I_{DD}$	Power Supply Current	ENABLE [1:2] = 00			8	mA
$I_{DDO}$	Output Supply Current	ENABLE [1:2] = 00			4	mA

**Table 4C. Power Supply DC Characteristics,  $V_{DD} = V_{DDO} = 1.8V \pm 0.2V$ ,  $T_A = 0^\circ C$  to  $70^\circ C$**

Symbol	Parameter	Test Conditions	Minimum	Typical	Maximum	Units
$V_{DD}$	Power Supply Voltage		1.6	1.8	2.0	V
$V_{DDO}$	Output Supply Voltage		1.6	1.8	2.0	V
$I_{DD}$	Power Supply Current	ENABLE [1:2] = 00			5	mA
$I_{DDO}$	Output Supply Current	ENABLE [1:2] = 00			3	mA

**Table 4D. Power Supply DC Characteristics,  $V_{DD} = 3.3V \pm 5\%$ ,  $V_{DDO} = 2.5V \pm 5\%$ ,  $T_A = 0^\circ\text{C}$  to  $70^\circ\text{C}$**

Symbol	Parameter	Test Conditions	Minimum	Typical	Maximum	Units
$V_{DD}$	Power Supply Voltage		3.135	3.3	3.465	V
$V_{DDO}$	Output Supply Voltage		2.375	2.5	2.625	V
$I_{DD}$	Power Supply Current	ENABLE [1:2] = 00			10	mA
$I_{DDO}$	Output Supply Current	ENABLE [1:2] = 00			4	mA

**Table 4E. Power Supply DC Characteristics,  $3.3V \pm 5\%$ ,  $V_{DDO} = 1.8V \pm 0.2V$ ,  $T_A = 0^\circ\text{C}$  to  $70^\circ\text{C}$**

Symbol	Parameter	Test Conditions	Minimum	Typical	Maximum	Units
$V_{DD}$	Power Supply Voltage		3.135	3.3	3.465	V
$V_{DDO}$	Output Supply Voltage		1.6	1.8	2.0	V
$I_{DD}$	Power Supply Current	ENABLE [1:2] = 00			10	mA
$I_{DDO}$	Output Supply Current	ENABLE [1:2] = 00			3	mA

**Table 4F. Power Supply DC Characteristics,  $V_{DD} = 2.5V \pm 5\%$ ,  $V_{DDO} = 1.8V \pm 0.2V$ ,  $T_A = 0^\circ\text{C}$  to  $70^\circ\text{C}$**

Symbol	Parameter	Test Conditions	Minimum	Typical	Maximum	Units
$V_{DD}$	Power Supply Voltage		2.375	2.5	2.625	V
$V_{DDO}$	Output Supply Voltage		1.6	1.8	2.0	V
$I_{DD}$	Power Supply Current	ENABLE [1:2] = 00			8	mA
$I_{DDO}$	Output Supply Current	ENABLE [1:2] = 00			3	mA

**Table 4G. LVCMOS/LVTTL DC Characteristics,  $T_A = 0^\circ\text{C}$  to  $70^\circ\text{C}$** 

Symbol	Parameter		Test Conditions	Minimum	Typical	Maximum	Units
$V_{IH}$	Input High Voltage	ENABLE1, ENABLE2	$V_{DD} = 3.3V \pm 5\%$	2		$V_{DD} + 0.3$	V
			$V_{DD} = 2.5V \pm 5\%$	1.7		$V_{DD} + 0.3$	V
			$V_{DD} = 1.8V \pm 0.2V$	$0.65 * V_{DD}$		$V_{DD} + 0.3$	V
$V_{IL}$	Input Low Voltage	ENABLE1, ENABLE2	$V_{DD} = 3.3V \pm 5\%$	-0.3		0.8	V
			$V_{DD} = 2.5V \pm 5\%$	-0.3		0.7	V
			$V_{DD} = 1.8V \pm 0.2V$	-0.3		$0.35 * V_{DD}$	V
$V_{OH}$	Output High Voltage		$V_{DDO} = 3.3V \pm 5\%$ ; NOTE 1	2.6			V
			$V_{DDO} = 2.5V \pm 5\%$ ; $I_{OH} = -1\text{mA}$	2.0			V
			$V_{DDO} = 2.5V \pm 5\%$ ; NOTE 1	1.8			V
			$V_{DDO} = 1.8V \pm 0.2V$ ; NOTE 1	$V_{DDO} - 0.3$			V
$V_{OL}$	Output Low Voltage; NOTE 1		$V_{DDO} = 3.3V \pm 5\%$ ; NOTE 1			0.5	V
			$V_{DDO} = 2.5V \pm 5\%$ ; $I_{OL} = 1\text{mA}$			0.4	V
			$V_{DDO} = 2.5V \pm 5\%$ ; NOTE 1			0.45	V
			$V_{DDO} = 1.8V \pm 0.2V$ ; NOTE 1			0.35	V

NOTE 1: Outputs terminated with  $50\Omega$  to  $V_{DDO}/2$ . See Parameter Measurement Information, *Output Load Test Circuit diagrams*.

**Table 5. Crystal Characteristics**

Parameter	Test Conditions	Minimum	Typical	Maximum	Units
Mode of Oscillation		Fundamental			
Frequency		10		40	MHz
Equivalent Series Resistance (ESR)				50	$\Omega$
Shunt Capacitance				7	pF
Drive Level				1	mW

## AC Electrical Characteristics

**Table 6A. AC Characteristics,  $V_{DD} = V_{DDO} = 3.3V \pm 5\%$ ,  $T_A = 0^\circ C$  to  $70^\circ C$**

Symbol	Parameter	Test Conditions	Minimum	Typical	Maximum	Units
$f_{MAX}$	Output Frequency	Using External Crystal	10		40	MHz
		Using External Clock Source NOTE 1	DC		100	MHz
$t_{sk(o)}$	Output Skew; NOTE 2, 3				80	ps
$t_{jit}(\emptyset)$	RMS Phase Jitter (Random); NOTE 4	25MHz, Integration Range: 100Hz – 1MHz		0.13		ps
$t_R / t_F$	Output Rise/Fall Time	20% to 80%	200		800	ps
odc	Output Duty Cycle		48		52	%
$t_{EN}$	Output Enable Time; NOTE 5	ENABLE1			4	cycles
		ENABLE2			4	cycles
$t_{DIS}$	Output Disable Time; NOTE 5	ENABLE1			4	cycles
		ENABLE2			4	cycles

NOTE: Electrical parameters are guaranteed over the specified ambient operating temperature range, which is established when the device is mounted in a test socket with maintained transverse airflow greater than 500 lfm. The device will meet specifications after thermal equilibrium has been reached under these conditions.

All parameters measured at  $f \leq f_{MAX}$  using a crystal input unless noted otherwise.

Terminated at  $50\Omega$  to  $V_{DDO}/2$ .

NOTE 1: XTAL\_IN can be overdriven by a single-ended LVCMOS signal. Please refer to Application Information section.

NOTE 2: Defined as skew between outputs at the same supply voltage and with equal load conditions. Measured at  $V_{DDO}/2$ .

NOTE 3: This parameter is defined in accordance with JEDEC Standard 65.

NOTE 4: See phase noise plot.

NOTE 5: These parameters are guaranteed by characterization. Not tested in production.

**Table 6B. AC Characteristics,  $V_{DD} = V_{DDO} = 2.5V \pm 5\%$ ,  $T_A = 0^\circ C$  to  $70^\circ C$**

Symbol	Parameter	Test Conditions	Minimum	Typical	Maximum	Units
$f_{MAX}$	Output Frequency	Using External Crystal	10		40	MHz
		Using External Clock Source NOTE 1	DC		100	MHz
$t_{sk(o)}$	Output Skew; NOTE 2, 3				80	ps
$t_{jit}$	RMS Phase Jitter (Random); NOTE 4	25MHz, Integration Range: 100Hz – 1MHz		0.26		ps
$t_R / t_F$	Output Rise/Fall Time	20% to 80%	200		800	ps
odc	Output Duty Cycle		47		53	%
$t_{EN}$	Output Enable Time; NOTE 5	ENABLE1			4	cycles
		ENABLE2			4	cycles
$t_{DIS}$	Output Disable Time; NOTE 5	ENABLE1			4	cycles
		ENABLE2			4	cycles

NOTE: Electrical parameters are guaranteed over the specified ambient operating temperature range, which is established when the device is mounted in a test socket with maintained transverse airflow greater than 500 lfm. The device will meet specifications after thermal equilibrium has been reached under these conditions.

All parameters measured at  $f \leq f_{MAX}$  using a crystal input unless noted otherwise.

Terminated at  $50\Omega$  to  $V_{DDO}/2$ .

NOTE 1: XTAL\_IN can be overdriven by a single-ended LVCMOS signal. Please refer to Application Information section.

NOTE 2: Defined as skew between outputs at the same supply voltage and with equal load conditions. Measured at  $V_{DDO}/2$ .

NOTE 3: This parameter is defined in accordance with JEDEC Standard 65.

NOTE 4: See phase noise plot.

NOTE 5: These parameters are guaranteed by characterization. Not tested in production.

**Table 6C. AC Characteristics,  $V_{DD} = V_{DDO} = 1.8V \pm 0.2V$ ,  $T_A = 0^\circ\text{C}$  to  $70^\circ\text{C}$** 

Symbol	Parameter		Test Conditions	Minimum	Typical	Maximum	Units
$f_{MAX}$	Output Frequency	Using External Crystal		10		40	MHz
		Using External Clock Source NOTE 1		DC		100	MHz
$t_{sk(o)}$	Output Skew; NOTE 2, 3					80	ps
$t_{jit}(\emptyset)$	RMS Phase Jitter (Random)		25MHz, Integration Range: 100Hz – 1MHz		0.27		ps
$t_R / t_F$	Output Rise/Fall Time		20% to 80%	200		900	ps
odc	Output Duty Cycle			47		53	%
$t_{EN}$	Output Enable Time; NOTE 4	ENABLE1				4	cycles
		ENABLE2				4	cycles
$t_{DIS}$	Output Disable Time; NOTE 4	ENABLE1				4	cycles
		ENABLE2				4	cycles

NOTE: Electrical parameters are guaranteed over the specified ambient operating temperature range, which is established when the device is mounted in a test socket with maintained transverse airflow greater than 500 lfm. The device will meet specifications after thermal equilibrium has been reached under these conditions.

All parameters measured at  $f \leq f_{MAX}$  using a crystal input unless noted otherwise.

Terminated at  $50\Omega$  to  $V_{DDO}/2$ .

NOTE 1: XTAL\_IN can be overdriven by a single-ended LVCMOS signal. Please refer to Application Information section.

NOTE 2: Defined as skew between outputs at the same supply voltage and with equal load conditions. Measured at  $V_{DDO}/2$ .

NOTE 3: This parameter is defined in accordance with JEDEC Standard 65.

NOTE 4: These parameters are guaranteed by characterization. Not tested in production.

**Table 6D. AC Characteristics,  $V_{DD} = 3.3V \pm 5\%$ ,  $V_{DDO} = 2.5V \pm 5\%$ ,  $T_A = 0^\circ\text{C}$  to  $70^\circ\text{C}$** 

Symbol	Parameter		Test Conditions	Minimum	Typical	Maximum	Units
$f_{MAX}$	Output Frequency	Using External Crystal		10		40	MHz
		Using External Clock Source NOTE 1		DC		100	MHz
$t_{sk(o)}$	Output Skew; NOTE 2, 3					80	ps
$t_{jit}$	RMS Phase Jitter (Random)		25MHz, Integration Range: 100Hz – 1MHz		0.14		ps
$t_R / t_F$	Output Rise/Fall Time		20% to 80%	200		800	ps
odc	Output Duty Cycle			48		52	%
$t_{EN}$	Output Enable Time; NOTE 4	ENABLE1				4	cycles
		ENABLE2				4	cycles
$t_{DIS}$	Output Disable Time; NOTE 4	ENABLE1				4	cycles
		ENABLE2				4	cycles

NOTE: Electrical parameters are guaranteed over the specified ambient operating temperature range, which is established when the device is mounted in a test socket with maintained transverse airflow greater than 500 lfm. The device will meet specifications after thermal equilibrium has been reached under these conditions.

All parameters measured at  $f \leq f_{MAX}$  using a crystal input unless noted otherwise.

Terminated at  $50\Omega$  to  $V_{DDO}/2$ .

NOTE 1: XTAL\_IN can be overdriven by a single-ended LVCMOS signal. Please refer to Application Information section.

NOTE 2: Defined as skew between outputs at the same supply voltage and with equal load conditions. Measured at  $V_{DDO}/2$ .

NOTE 3: This parameter is defined in accordance with JEDEC Standard 65.

NOTE 4: These parameters are guaranteed by characterization. Not tested in production.

**Table 6E. AC Characteristics,  $V_{DD} = 3.3V \pm 5\%$ ,  $V_{DDO} = 1.8V \pm 0.2V$ ,  $T_A = 0^\circ C$  to  $70^\circ C$** 

Symbol	Parameter		Test Conditions	Minimum	Typical	Maximum	Units
$f_{MAX}$	Output Frequency	Using External Crystal		10		40	MHz
		Using External Clock Source NOTE 1		DC		100	MHz
$t_{sk(o)}$	Output Skew; NOTE 2, 3					80	ps
$t_{jit}$	RMS Phase Jitter (Random)		25MHz, Integration Range: 100Hz – 1MHz		0.18		ps
$t_R / t_F$	Output Rise/Fall Time		20% to 80%	200		900	ps
odc	Output Duty Cycle			48		52	%
$t_{EN}$	Output Enable Time; NOTE 4	ENABLE1				4	cycles
		ENABLE2				4	cycles
$t_{DIS}$	Output Disable Time; NOTE 4	ENABLE1				4	cycles
		ENABLE2				4	cycles

NOTE: Electrical parameters are guaranteed over the specified ambient operating temperature range, which is established when the device is mounted in a test socket with maintained transverse airflow greater than 500 lfm. The device will meet specifications after thermal equilibrium has been reached under these conditions.

All parameters measured at  $f \leq f_{MAX}$  using a crystal input unless noted otherwise.

Terminated at  $50\Omega$  to  $V_{DDO}/2$ .

NOTE 1: XTAL\_IN can be overdriven by a single-ended LVCMOS signal. Please refer to Application Information section.

NOTE 2: Defined as skew between outputs at the same supply voltage and with equal load conditions. Measured at  $V_{DDO}/2$ .

NOTE 3: This parameter is defined in accordance with JEDEC Standard 65.

NOTE 4: These parameters are guaranteed by characterization. Not tested in production.

**Table 6F. AC Characteristics,  $V_{DD} = 2.5V \pm 5\%$ ,  $V_{DDO} = 1.8V \pm 0.2V$ ,  $T_A = 0^\circ C$  to  $70^\circ C$** 

Symbol	Parameter		Test Conditions	Minimum	Typical	Maximum	Units
$f_{MAX}$	Output Frequency	Using External Crystal		10		40	MHz
		Using External Clock Source NOTE 1		DC		100	MHz
$t_{sk(o)}$	Output Skew; NOTE 2, 3					80	ps
$t_{jit}$	RMS Phase Jitter (Random)		25MHz, Integration Range: 100Hz – 1MHz		0.19		ps
$t_R / t_F$	Output Rise/Fall Time		20% to 80%	200		900	ps
odc	Output Duty Cycle			47		53	%
$t_{EN}$	Output Enable Time; NOTE 4	ENABLE1				4	cycles
		ENABLE2				4	cycles
$t_{DIS}$	Output Disable Time; NOTE 4	ENABLE1				4	cycles
		ENABLE2				4	cycles

NOTE: Electrical parameters are guaranteed over the specified ambient operating temperature range, which is established when the device is mounted in a test socket with maintained transverse airflow greater than 500 lfm. The device will meet specifications after thermal equilibrium has been reached under these conditions.

All parameters measured at  $f \leq f_{MAX}$  using a crystal input unless noted otherwise.

Terminated at  $50\Omega$  to  $V_{DDO}/2$ .

NOTE 1: XTAL\_IN can be overdriven by a single-ended LVCMOS signal. Please refer to Application Information section.

NOTE 2: Defined as skew between outputs at the same supply voltage and with equal load conditions. Measured at  $V_{DDO}/2$ .

NOTE 3: This parameter is defined in accordance with JEDEC Standard 65.

NOTE 4: These parameters are guaranteed by characterization. Not tested in production.



Typical Phase Noise at 25MHz (2.5V Core/2.5V Output)

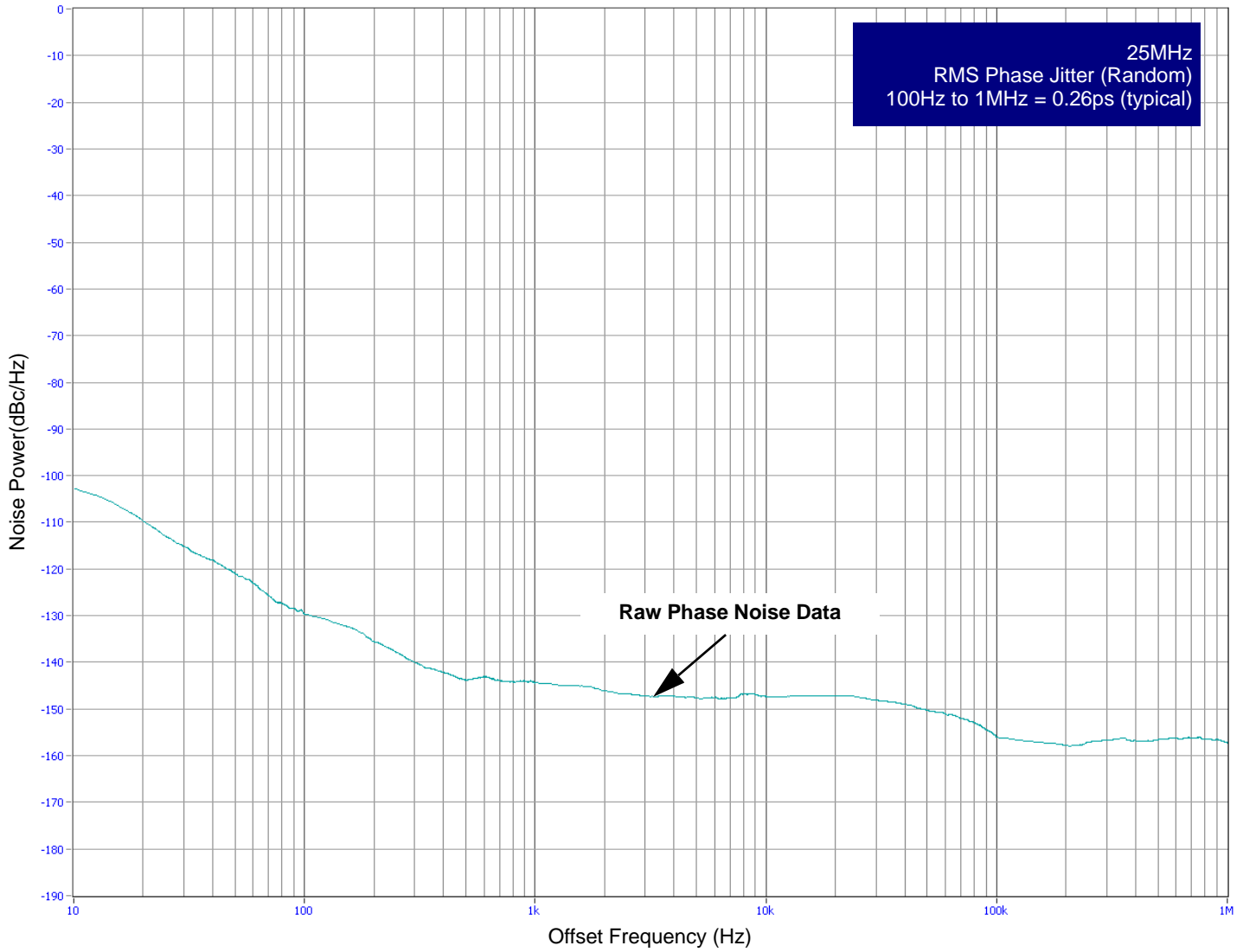

## Parameter Measurement Information

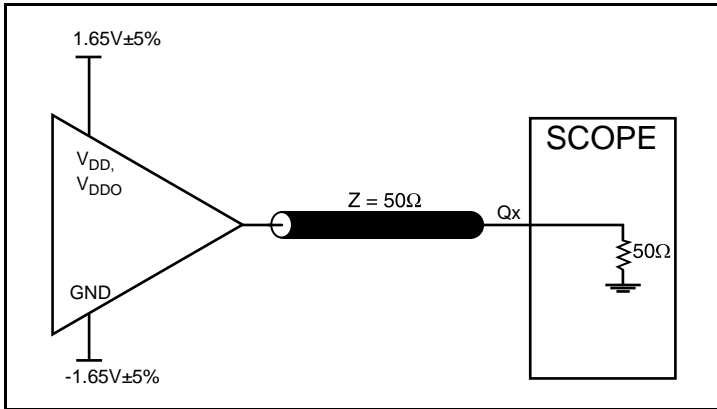

3.3V Core/3.3V LVCMOS Output Load AC Test Circuit

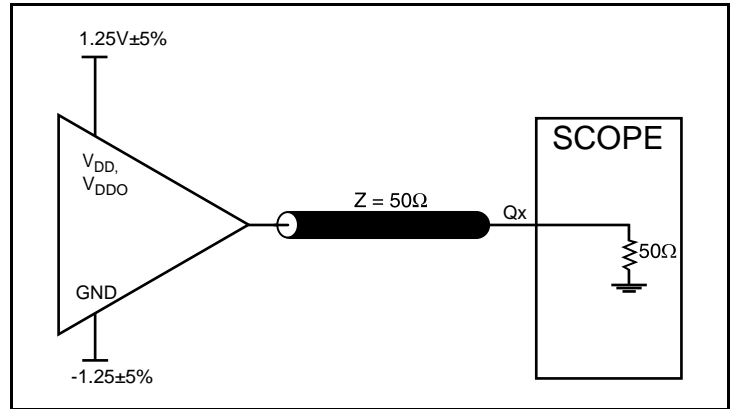

2.5V Core/2.5V LVCMOS Output Load AC Test Circuit

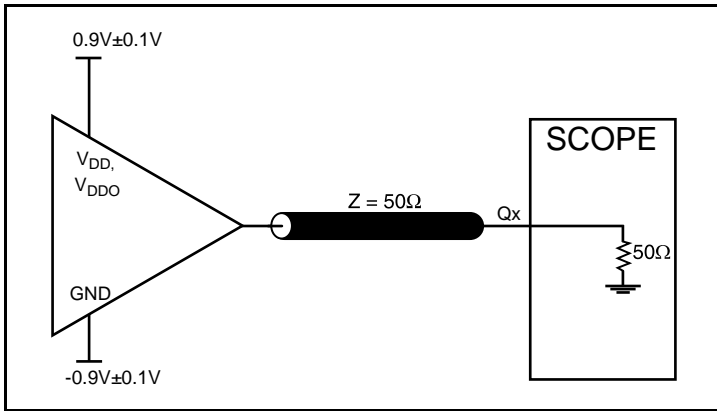

1.8V Core/1.8V LVCMOS Output Load AC Test Circuit

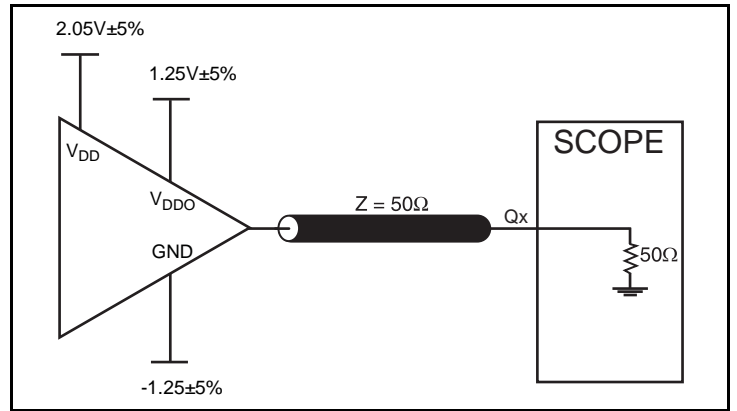

3.3V Core/2.5V LVCMOS Output Load AC Test Circuit

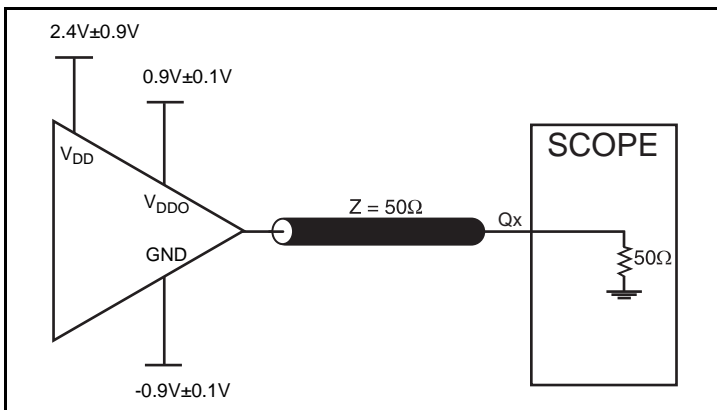

3.3V Core/1.8V LVCMOS Output Load AC Test Circuit

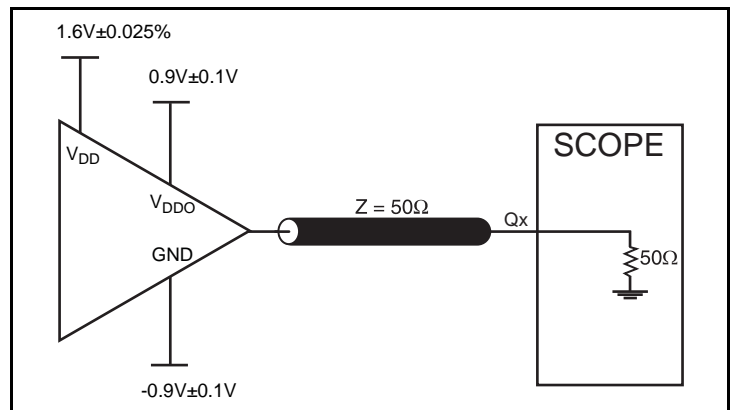

2.5V Core/1.8V LVCMOS Output Load AC Test Circuit

Parameter Measurement Information, continued

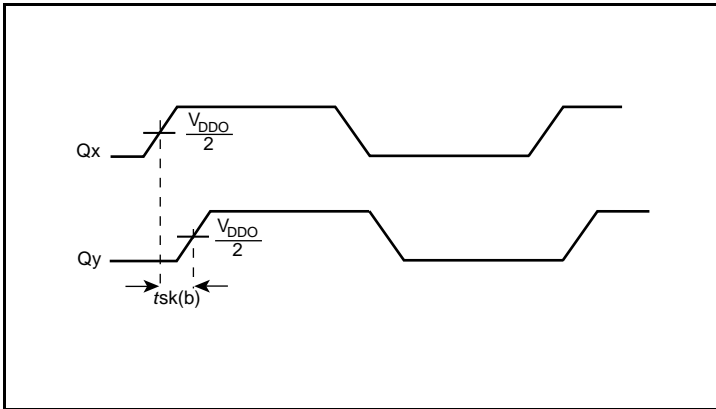

Output Skew

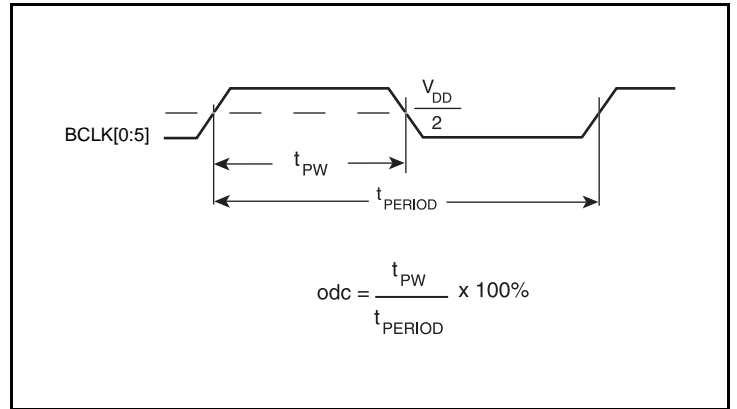

Output Duty Cycle/Pulse Width/Period

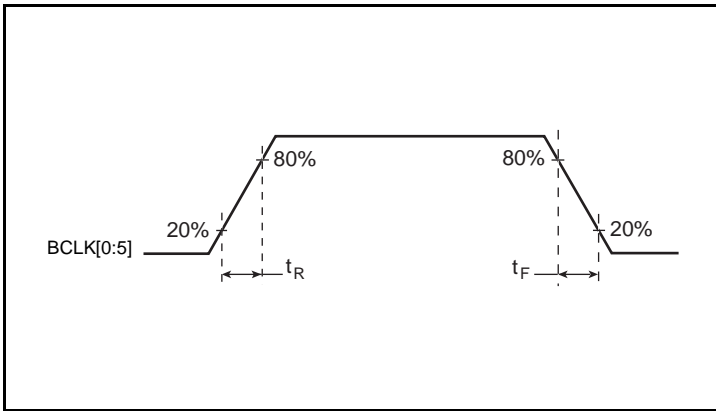

Output Rise/Fall Time

## Application Information

### Crystal Input Interface

Figure 2 shows an example of 83905 crystal interface with a parallel resonant crystal. The frequency accuracy can be fine tuned by adjusting the C1 and C2 values. For a parallel crystal with loading capacitance  $C_L = 18\text{pF}$ , to start with, we suggest  $C_1 = 15\text{pF}$  and  $C_2 = 15\text{pF}$ . These values may be slightly fine tuned further to optimize the frequency accuracy for different board

layouts. Slightly increasing the C1 and C2 values will slightly reduce the frequency. Slightly decreasing the C1 and C2 values will slightly increase the frequency. For the oscillator circuit below, R1 can be used, but is not required. For new designs, it is recommended that R1 not be used.

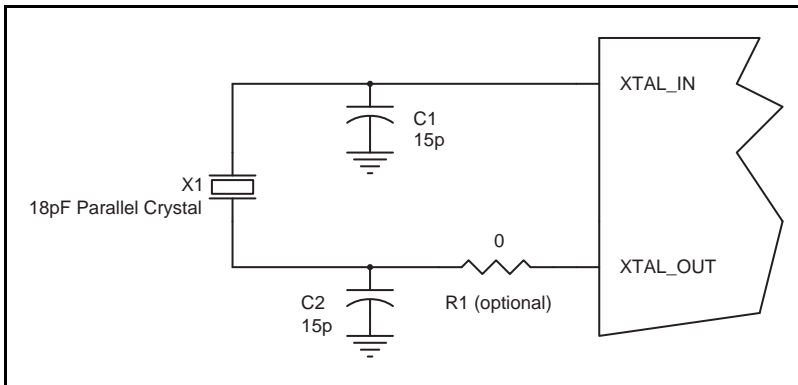

Figure 2. Crystal Input Interface

### LVC MOS to XTAL Interface

The XTAL\_IN input can accept a single-ended LVC MOS signal through an AC coupling capacitor. A general interface diagram is shown in Figure 3. The XTAL\_OUT pin can be left floating. The input edge rate can be as slow as 10ns. For LVC MOS inputs, it is recommended that the amplitude be reduced from full swing to half swing in order to prevent signal interference with the power rail and to reduce noise. This configuration requires that the output impedance of the driver ( $R_o$ ) plus the series resistance ( $R_s$ ) equals

the transmission line impedance. In addition, matched termination at the crystal input will attenuate the signal in half. This can be done in one of two ways. First, R1 and R2 in parallel should equal the transmission line impedance. For most  $50\Omega$  applications, R1 and R2 can be  $100\Omega$ . This can also be accomplished by removing R1 and making R2  $50\Omega$ . By overdriving the crystal oscillator, the device will be functional, but note, the device performance is guaranteed by using a quartz crystal.

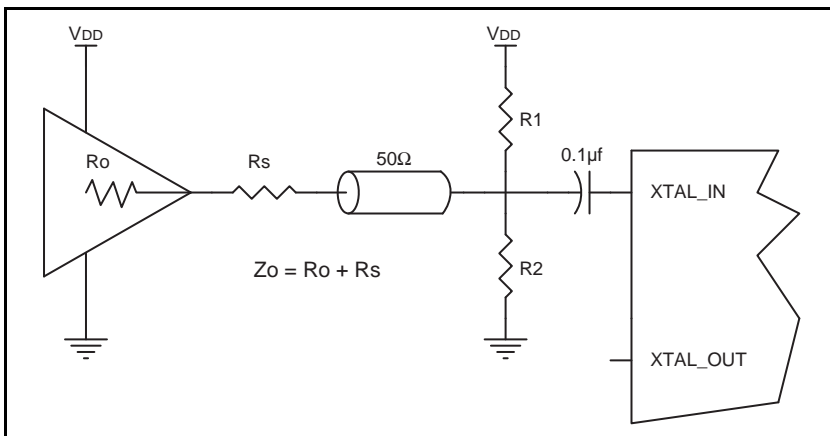

Figure 3. General Diagram for LVC MOS Driver to XTAL Input Interface

## VFQFN EPAD Thermal Release Path

In order to maximize both the removal of heat from the package and the electrical performance, a land pattern must be incorporated on the Printed Circuit Board (PCB) within the footprint of the package corresponding to the exposed metal pad or exposed heat slug on the package, as shown in *Figure 4*. The solderable area on the PCB, as defined by the solder mask, should be at least the same size/shape as the exposed pad/slug area on the package to maximize the thermal/electrical performance. Sufficient clearance should be designed on the PCB between the outer edges of the land pattern and the inner edges of pad pattern for the leads to avoid any shorts.

While the land pattern on the PCB provides a means of heat transfer and electrical grounding from the package to the board through a solder joint, thermal vias are necessary to effectively conduct from the surface of the PCB to the ground plane(s). The land pattern must be connected to ground through these vias. The vias act as “heat pipes”. The number of vias (i.e. “heat pipes”) are

application specific and dependent upon the package power dissipation as well as electrical conductivity requirements. Thus, thermal and electrical analysis and/or testing are recommended to determine the minimum number needed. Maximum thermal and electrical performance is achieved when an array of vias is incorporated in the land pattern. It is recommended to use as many vias connected to ground as possible. It is also recommended that the via diameter should be 12 to 13mils (0.30 to 0.33mm) with 1oz copper via barrel plating. This is desirable to avoid any solder wicking inside the via during the soldering process which may result in voids in solder between the exposed pad/slug and the thermal land. Precautions should be taken to eliminate any solder voids between the exposed heat slug and the land pattern. Note: These recommendations are to be used as a guideline only. For further information, please refer to the Application Note on the Surface Mount Assembly of Amkor’s Thermally/Electrically Enhance Leadframe Base Package, Amkor Technology.

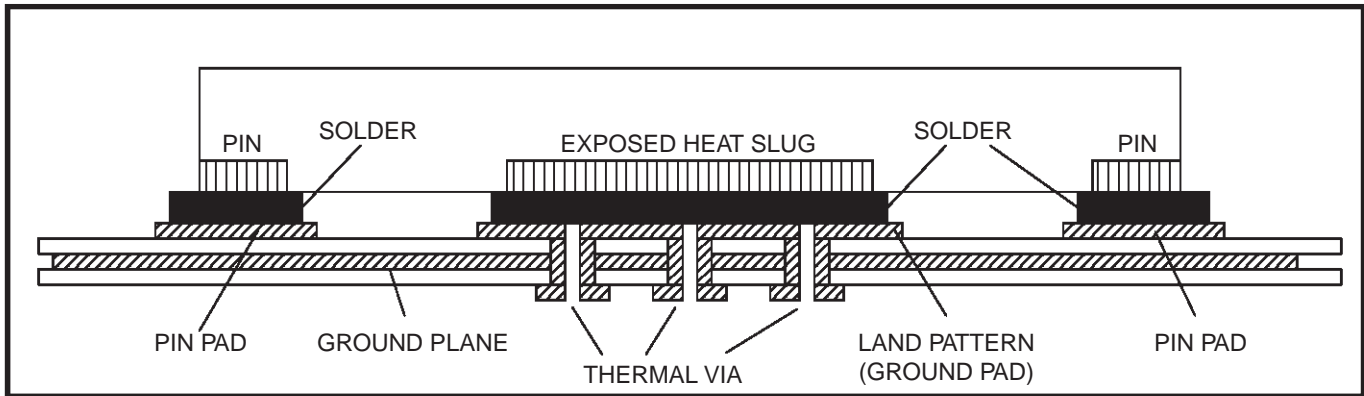

Figure 4. P.C. Assembly for Exposed Pad Thermal Release Path – Side View (drawing not to scale)

## Recommendations for Unused Input and Output Pins

### Inputs:

#### LVC MOS Control Pins

All control pins have internal pull-ups or pull-downs; additional resistance is not required but can be added for additional protection. A 1kΩ resistor can be used.

### Outputs:

#### LVC MOS Outputs

All unused LVC MOS output can be left floating. There should be no trace attached.

## Layout Guideline

Figure 5 shows an example of 83905 application schematic. The schematic example focuses on functional connections and is not configuration specific. In this example, the device is operated at  $V_{DD} = 3.3V$  and  $V_{DDO} = 1.8V$ . The crystal inputs are loaded with an 18pF load resonant quartz crystal. The tuning capacitors (C1, C2) are fairly accurate, but minor adjustments might be required. Refer to the pin description and functional tables in the datasheet to ensure the logic control inputs are properly set. For the LVC MOS output drivers, two termination examples are shown in the schematic. For additional termination examples are shown in the LVC MOS Termination Application Note.

As with any high speed analog circuitry, the power supply pins are vulnerable to random noise. To achieve optimum jitter performance, power supply isolation is required. The 83905 provides separate  $V_{DD}$  and  $V_{DDO}$  power supplies to isolate any high switching noise from coupling into the internal oscillator. In order to achieve the best possible filtering, it is highly

recommended that the 0.1uF capacitors on the device side of the ferrite beads be placed on the device side of the PCB as close to the power pins as possible. This is represented by the placement of these capacitors in the schematic. If space is limited, the ferrite beads, 10uF and 0.1uF capacitor connected to the board supplies can be placed on the opposite side of the PCB. If space permits, place all filter components on the device side of the board.

Power supply filter recommendations are a general guideline to be used for reducing external noise from coupling into the devices. The filter performance is designed for a wide range of noise frequencies. This low-pass filter starts to attenuate noise at approximately 0kHz. If a specific frequency noise component is known, such as switching power supplies frequencies, it is recommended that component values be adjusted and if required, additional filtering be added. Additionally, good general design practices for power plane voltage stability suggests adding bulk capacitance in the local area of all devices.

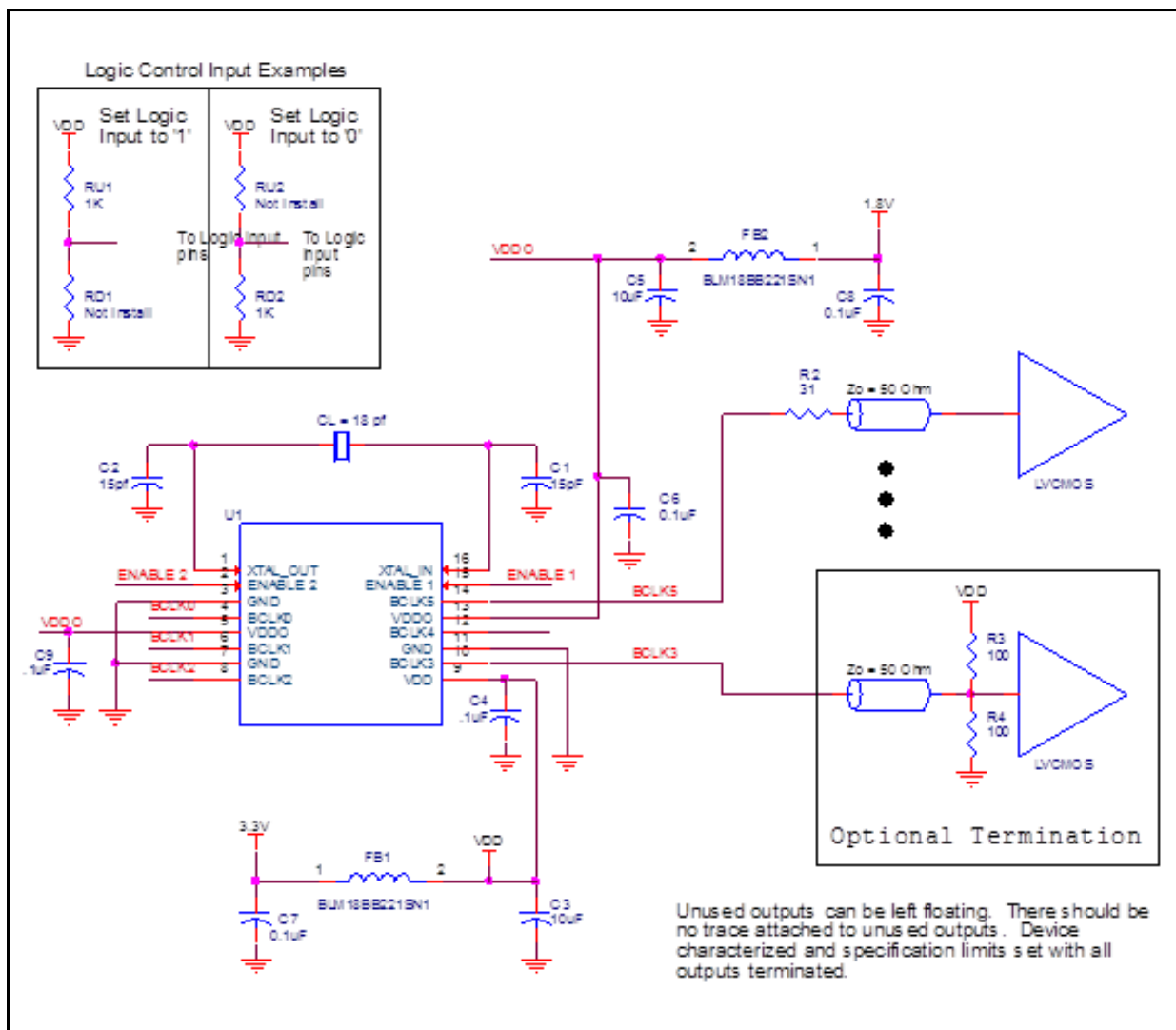

Figure 5. Schematic of Recommended Layout

## Power Considerations

This section provides information on power dissipation and junction temperature for the 83905. Equations and example calculations are also provided.

### 1. Power Dissipation.

The total power dissipation for the 83905 is the sum of the core power plus the analog power plus the power dissipated due to the load. The following is the power dissipation for  $V_{DD} = 3.3V + 5\% = 3.465V$ , which gives worst case results.

- Power (core)<sub>MAX</sub> =  $V_{DD\_MAX} * (I_{DD} + I_{DDO}) = 3.465V * (10mA + 5mA) = \mathbf{51.9mW}$
- Output Impedance  $R_{OUT}$  Power Dissipation due to Loading  $50\Omega$  to  $V_{DD}/2$   
Output Current  $I_{OUT} = V_{DD\_MAX} / [2 * (50\Omega + R_{OUT})] = 3.465V / [2 * (50\Omega + 7\Omega)] = \mathbf{30.4mA}$
- Power Dissipation on the  $R_{OUT}$  per LVCMOS output  
Power  $(R_{OUT}) = R_{OUT} * (I_{OUT})^2 = 7\Omega * (30.4mA)^2 = \mathbf{6.5mW}$  per output
- Total Power Dissipation on the  $R_{OUT}$   
**Total Power  $(R_{OUT}) = 6.5mW * 6 = 39mW$**

### Dynamic Power Dissipation at 25MHz

Power (25MHz) =  $C_{PD} * \text{Frequency} * (V_{DD})^2 = 19pF * 25MHz * (3.465V)^2 = \mathbf{5.70mW}$  per output  
**Total Power (25MHz) = 5.70mW \* 6 = 34.2mW**

### Total Power Dissipation

- **Total Power**  
= Power (core)<sub>MAX</sub> + Total Power ( $R_{OUT}$ ) + Total Power (25MHz)  
= 51.98mW + 39mW + 34.2mW  
= **125.1mW**

### 2. Junction Temperature.

Junction temperature,  $T_j$ , is the temperature at the junction of the bond wire and bond pad and directly affects the reliability of the device. The maximum recommended junction temperature is 125°C.

The equation for  $T_j$  is as follows:  $T_j = \theta_{JA} * Pd\_total + T_A$

$T_j$  = Junction Temperature

$\theta_{JA}$  = Junction-to-Ambient Thermal Resistance

$Pd\_total$  = Total Device Power Dissipation (example calculation is in section 1 above)

$T_A$  = Ambient Temperature

In order to calculate junction temperature, the appropriate junction-to-ambient thermal resistance  $\theta_{JA}$  must be used. Assuming no air flow and a multi-layer board, the appropriate value is 100.3°C/W per Table 7 below.

Therefore,  $T_j$  for an ambient temperature of 70°C with all outputs switching is:

$70^\circ\text{C} + 0.125\text{W} * 100.3^\circ\text{C}/\text{W} = 82.5^\circ\text{C}$ . This is below the limit of 125°C.

This calculation is only an example.  $T_j$  will obviously vary depending on the number of loaded outputs, supply voltage, air flow and the type of board (multi-layer).

**Table 7. Thermal Resistance  $\theta_{JA}$  for 16-Lead TSSOP, Forced Convection**

Meters per Second	$\theta_{JA}$ by Velocity		
	0	1	2.5
Multi-Layer PCB, JEDEC Standard Test Boards	100.3°C/W	96.0°C/W	93.9°C/W

## Reliability Information

**Table 8A.  $\theta_{JA}$  vs. Air Flow Table for a 16-Lead TSSOP**

$\theta_{JA}$ vs. Air Flow			
Meters per Second	0	1	2.5
Multi-Layer PCB, JEDEC Standard Test Boards	100.3°C/W	96.0°C/W	93.9°C/W

**Table 8B.  $\theta_{JA}$  vs. Air Flow Table for a 16-Lead SOIC**

$\theta_{JA}$ vs. Air Flow			
Meters per Second	0	1	2.5
Multi-Layer PCB, JEDEC Standard Test Boards	78.8°C/W	71.1°C/W	66.2°C/W

**Table 8C.  $\theta_{JA}$  vs. Air Flow Table for a 20-Lead VFQFN**

$\theta_{JA}$ vs. Air Flow			
Meters per Second	0	1	2.5
Multi-Layer PCB, JEDEC Standard Test Boards	57.5°C/W	50.3°C/W	45.1°C/W

## Transistor Count

The transistor count for 83905: 339



## Package Outline and Package Dimensions

### Package Outline - G Suffix for 16-Lead TSSOP

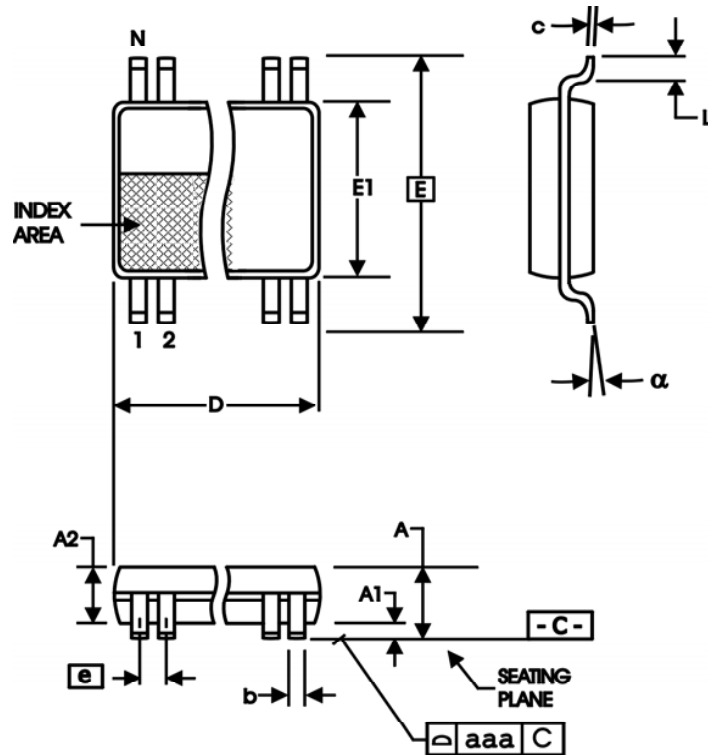

Table 9A. Package Dimensions for 16-Lead TSSOP

All Dimensions in Millimeters		
Symbol	Minimum	Maximum
N	16	
A		1.20
A1	0.05	0.15
A2	0.80	1.05
b	0.19	0.30
c	0.09	0.20
D	4.90	5.10
E	6.40 Basic	
E1	4.30	4.50
e	0.65 Basic	
L	0.45	0.75
$\alpha$	0°	8°
aaa		0.10

Reference Document: JEDEC Publication 95, MO-153

### Package Outline - M Suffix for 16-Lead SOIC

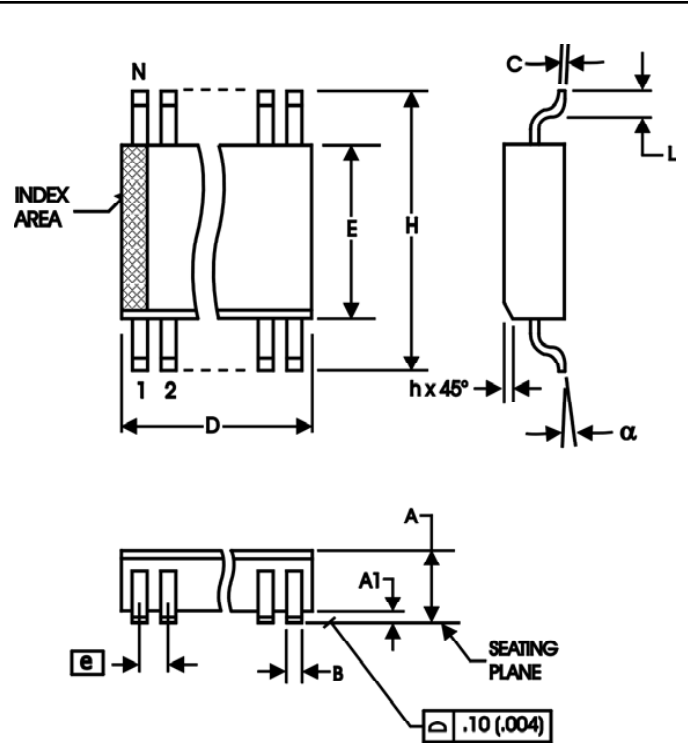

Table 9B. Package Dimensions for 16-Lead SOIC

All Dimensions in Millimeters		
Symbol	Minimum	Maximum
N	16	
A	1.35	1.75
A1	0.10	0.25
B	0.33	0.51
C	0.19	0.25
D	9.80	10.00
E	3.80	4.00
e	1.27 Basic	
H	5.80	6.20
L	0.40	1.27
$\alpha$	0°	8°

Reference Document: JEDEC Publication 95, MS-012

## Package Outline and Package Dimensions

### Package Outline - K Suffix for 20-Lead VFQFN

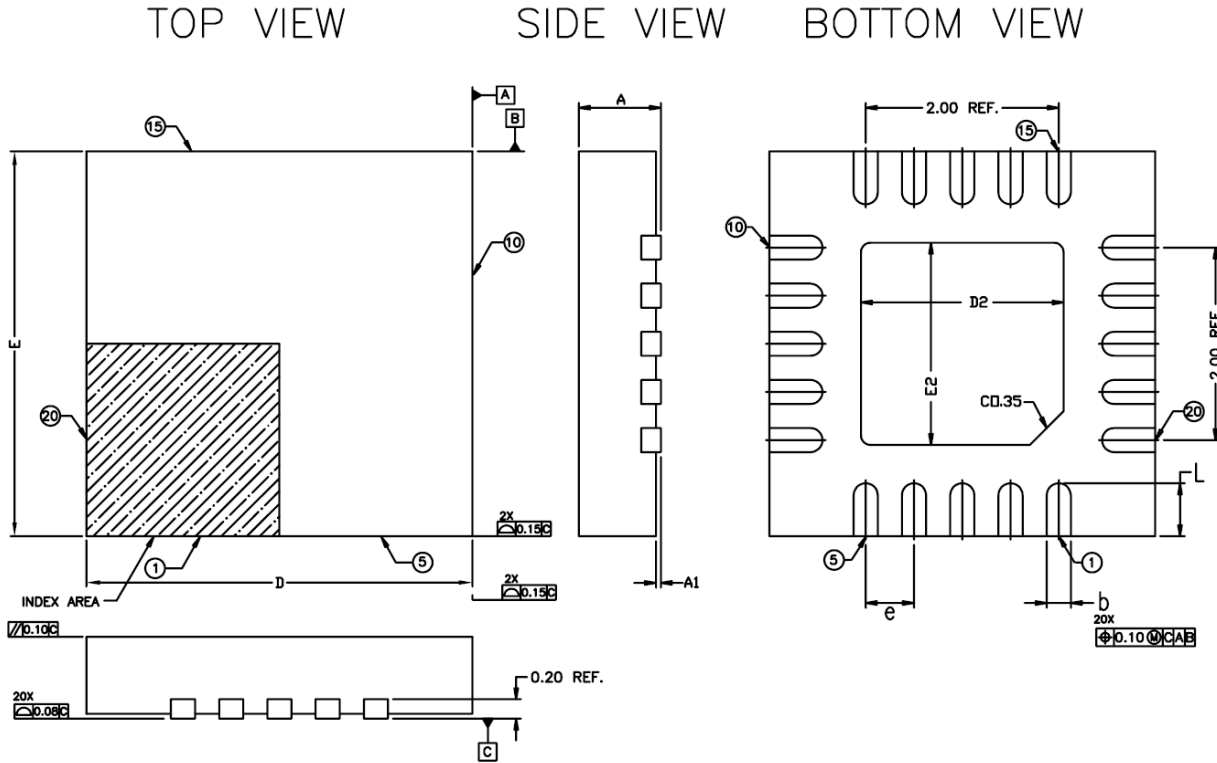

Table 10. Package Dimensions

All Dimensions in Millimeters			
Symbol	Minimum	Nominal	Maximum
N	20		
A	0.80		1.00
A1	0		0.05
A3	0.2 Ref.		
b	0.20	0.25	0.30
N <sub>D</sub> & N <sub>E</sub>	5		
D & E	4.00 Basic		
D2 & E2	1.95		2.25
e	0.50 Basic		
L	0.45	0.55	0.65

Reference Document: JEDEC Publication 95, MO-220

NOTE:

The drawing and dimension data originate from IDT package outline drawing PSC-4170, rev03.

1. Dimensions and tolerances conform to ASME Y14.5M-1994
2. All dimensions are in millimeters. All angles are in degrees.
3. N is the total number of terminals.
4. All specifications comply with JEDEC MO-220.

## Ordering Information

Table 11. Ordering Information

Part/Order Number	Marking	Package	Shipping Packaging	Temperature
83905AMLF	83905AML	"Lead-Free" 16-Lead SOIC	Tube	0°C to 70°C
83905AMLFT	83905AML	"Lead-Free" 16-Lead SOIC	Tape & Reel	0°C to 70°C
83905AGLF	83905AGL	"Lead-Free" 16-Lead TSSOP	Tube	0°C to 70°C
83905AGLFT	83905AGL	"Lead-Free" 16-Lead TSSOP	Tape & Reel	0°C to 70°C
83905AKLF	3905AL	"Lead-Free" 20-Lead VFQFN	Tray	0°C to 70°C
83905AKLFT	3905AL	"Lead-Free" 20-Lead VFQFN	Tape & Reel	0°C to 70°C

## Revision History Sheet

Rev	Table	Page	Description of Change	Date
A		2	Added Enable Timing Diagram.	3/28/05
B	T6A - T6F	1 5 - 7 8	Features Section - added RMS Phase Jitter bullet. AC Characteristics Tables - added RMS Phase Jitter specs. Added Phase Noise Plot.	4/8/05
B	T9	14	Ordering Information Table - added TSSOP, non-LF part number.	4/25/05
B		11 12	Added Crystal Input Interface in Application Section. Added Schematic layout.	5/16/05
B		3 11 13	Absolute Maximum Ratings - corrected 20-Lead VFQFN package Thermal Impedance. Added Recommendations for <i>Unused Input and Output Pins</i> . Corrected Theta JA Air Flow Table for 20-Lead VFQFN.	10/2/06
B	T9	11 12 17	Added <i>LVC MOS to XTAL Interface</i> section. Added <i>Thermal Release Path</i> section. AC Characteristics Table - added lead-free marking for 20-Lead VFQFN package.	7/9/07
B	T7B - T7C	3 12 14 16	Absolute Maximum Ratings - updated TSSOP and VFQFN Thermal Impedance. Updated Thermal Release Path section. Updated TSSOP and VFQFN Thermal Impedance. Added note to VFQFN Package Outline.	1/24/08
B		15	Added Power Considerations section. Converted datasheet format.	7/20/09
B	T10	19	Removed leaded order-able parts from Ordering Information table	11/14/12
C	T6D T9A T11	1, 15 1 7 14 17 18 19	Deleted HiPerClockS references. Features, last bullet: updated packaging note. Mixed AC Characteristics Table - corrected typo, switched <i>Output Rise/Fall Time spec</i> with <i>Output Duty Cycle spec</i> . Replaced schematic. 16-Lead TSSOP Package Table - corrected dimension A1 Minimum = 0.05. Updated VFQFN package outline page. Ordering Information table - deleted Lead-free note, and quantity from Tape and Reel.	4/18/13
C		1	Pin Assignment: Corrected 20-Lead illustration cut-off text	2/27/14
C	T6A - T6F T10	1 6 - 8 9 11 18 21	Pin Assignment, 20-Lead VFQFN: removed the Epad dimensions. Changed NOTE 1 to XTAL_IN can be overdriven by a single-ended LVC MOS signal. Please refer to Application Information section. Deleted 3.3V Phase Noise Plot Deleted RMS Phase Jitter graph. Modified dimensions to reflect tightened tolerances. Updated contact information.	8/6/14
D		2	Figure 1 corrected. Updated datasheet header/footer. Deleted "ICS" prefix from part number throughout the datasheet	9/27/16



## IMPORTANT NOTICE AND DISCLAIMER

RENESAS ELECTRONICS CORPORATION AND ITS SUBSIDIARIES (“RENESAS”) PROVIDES TECHNICAL SPECIFICATIONS AND RELIABILITY DATA (INCLUDING DATASHEETS), DESIGN RESOURCES (INCLUDING REFERENCE DESIGNS), APPLICATION OR OTHER DESIGN ADVICE, WEB TOOLS, SAFETY INFORMATION, AND OTHER RESOURCES “AS IS” AND WITH ALL FAULTS, AND DISCLAIMS ALL WARRANTIES, EXPRESS OR IMPLIED, INCLUDING, WITHOUT LIMITATION, ANY IMPLIED WARRANTIES OF MERCHANTABILITY, FITNESS FOR A PARTICULAR PURPOSE, OR NON-INFRINGEMENT OF THIRD PARTY INTELLECTUAL PROPERTY RIGHTS.

These resources are intended for developers skilled in the art designing with Renesas products. You are solely responsible for (1) selecting the appropriate products for your application, (2) designing, validating, and testing your application, and (3) ensuring your application meets applicable standards, and any other safety, security, or other requirements. These resources are subject to change without notice. Renesas grants you permission to use these resources only for development of an application that uses Renesas products. Other reproduction or use of these resources is strictly prohibited. No license is granted to any other Renesas intellectual property or to any third party intellectual property. Renesas disclaims responsibility for, and you will fully indemnify Renesas and its representatives against, any claims, damages, costs, losses, or liabilities arising out of your use of these resources. Renesas' products are provided only subject to Renesas' Terms and Conditions of Sale or other applicable terms agreed to in writing. No use of any Renesas resources expands or otherwise alters any applicable warranties or warranty disclaimers for these products.

(Rev.1.0 Mar 2020)

### Corporate Headquarters

TOYOSU FORESIA, 3-2-24 Toyosu,  
Koto-ku, Tokyo 135-0061, Japan  
[www.renesas.com](http://www.renesas.com)

### Contact Information

For further information on a product, technology, the most up-to-date version of a document, or your nearest sales office, please visit:  
[www.renesas.com/contact/](http://www.renesas.com/contact/)

### Trademarks

Renesas and the Renesas logo are trademarks of Renesas Electronics Corporation. All trademarks and registered trademarks are the property of their respective owners.

# Mouser Electronics

Authorized Distributor

Click to View Pricing, Inventory, Delivery & Lifecycle Information:

[Renesas Electronics:](#)

[83905AGLFT](#) [83905AMLF](#) [83905AGLF](#) [83905AKLF](#) [83905AMLFT](#) [83905AKLFT](#)