

UNCONTROLLED DOCUMENT
WILL NOT BE UPDATED

REV. SYM		ECO NUMBER	DESCRIPTION	BY DATE	APP'D DATE
1			ORIGINAL RELEASE	MF 3-28-11	
2			ADDED NOTE 2	MF 8-31-11	

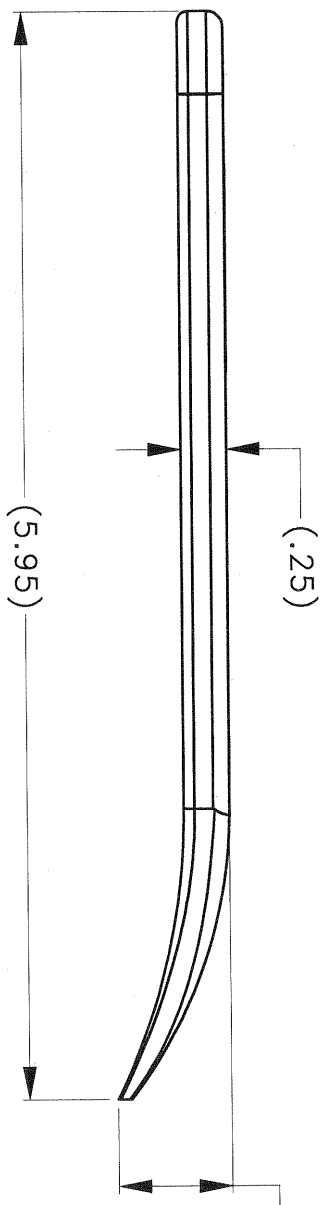
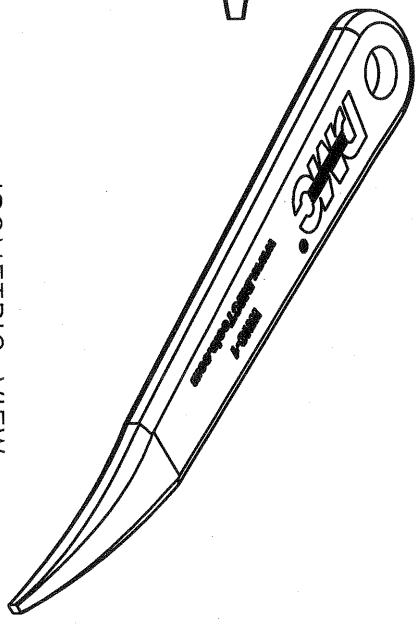

2. NSN: 5895-01-598-1301
1. ALL DIMENSIONS IN INCHES.

NOTES:

RESTRICTED & CONFIDENTIAL
CONFIDENTIAL PROPERTY OF DANIELS MANUFACTURING CORP. NOT TO BE DISCLOSED TO OTHERS, REPRODUCED OR USED FOR ANY OTHER PURPOSE EXCEPT AS AUTHORIZED IN WRITING, BY DANIELS MANUFACTURING. MUST BE RETURNED TO DANIELS MANUFACTURING CORP. ON COMPLETION OF ORDER OR OTHER PURPOSES FOR WHICH LENT.

CREATED FROM AN INVENTOR MODEL.
CHANGES MUST BE REFLECTED IN THE 3D PART

DO NOT SCALE DRAWING

MATERIAL	ITEM	PART NO.	QTY.	DESCRIPTION/REMARKS
HEAT TREAT	DRN. Matt Frink CHK'D.	DATE 3-28-11		
FINISH	APP'D.	DATE		

NOTE:		WHERE USED:	
THIS DRAWING IS AN OUTLINE DRAWING OF THE RESPECTIVE DMC PART NUMBER INDICATED. ACTUAL DMC PART NUMBER IS DRAWING PART NUMBER WITHOUT THE "-ENV" SUFFIX		SIZE	CAD P/N
		A	WHS-1-ENV
		SCALE 1:1	POSTING
			F/N
			WHS-1-ENV

TITLE	SHEET	OF
WIRE HARNESS SPOON ENVELOPE DRAWING	1	1

REV.	DATE
1	1
2	2

DMG DANIELS MANUFACTURING CORP.
ORLANDO, FLORIDA
CAGE 11851

Mouser Electronics

Authorized Distributor

Click to View Pricing, Inventory, Delivery & Lifecycle Information:

[Daniels Manufacturing:](#)

[WHS-1](#)