

| REVISIONS | | | | |
|-------------|-------------|-----------------------------|---------|------------|
| REV. NUMBER | EQD. NUMBER | DESCRIPTION | BY DATE | APP'D DATE |
| 2 | | REDESIGNED FOR ICP CONTACTS | 12-2-99 | 12-2-99 |

| ICP CONTACTS | COLOR | 10 | 12 | 14 | 16 | 18 | 20 | WIRE |
|-------------------|--------|----|----|----|----|----|----|---------------|
| SXC-88 & PXC-89 | BLUE | | | | 4 | | 2 | SEL. NO. |
| SXC-114 & PXC-115 | YELLOW | | | | | | 1 | USE WITH M309 |
| SXC-90 & PXC-91 | | | 6 | 5 | | | | |
| SXC-81 & PXC-82 | | | | 6 | 5 | | | |
| SXC-85 & PXC-86 | GREEN | | | | 4 | | 3 | |
| SXC-139 & PXC-140 | | | 8 | | | | | |

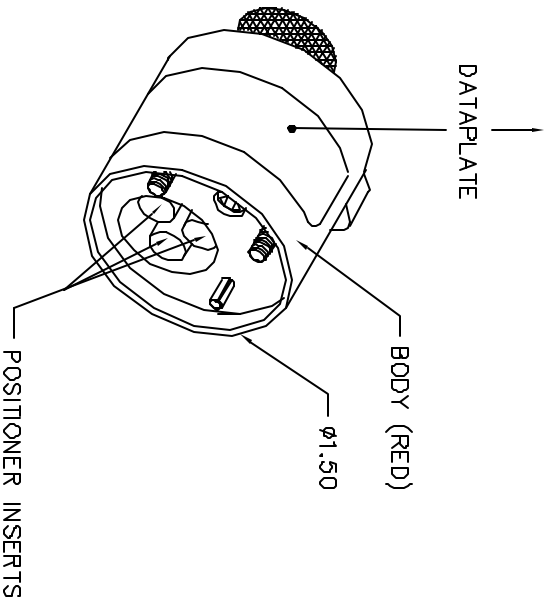

| POSITIONER COLOR | HOLE DIMS.* | ADDITIONAL FEATURES |
|------------------|------------------------------|-------------------------------------|
| BLUE | $\phi .067$ $\nabla .740$ | $\sqcup \phi .161$ $\nabla .595$ |
| YELLOW | $\phi .067$ $\nabla .740$ | $\sqcup \phi .169$ $\nabla .595$ |
| GREEN | $\phi .125$ $\nabla .522$ | $\sqcup \phi .191$ $\nabla .365$ |

*HOLE DEPTHS ARE MEASURED FROM TOP OF POSITIONER INSERTS.

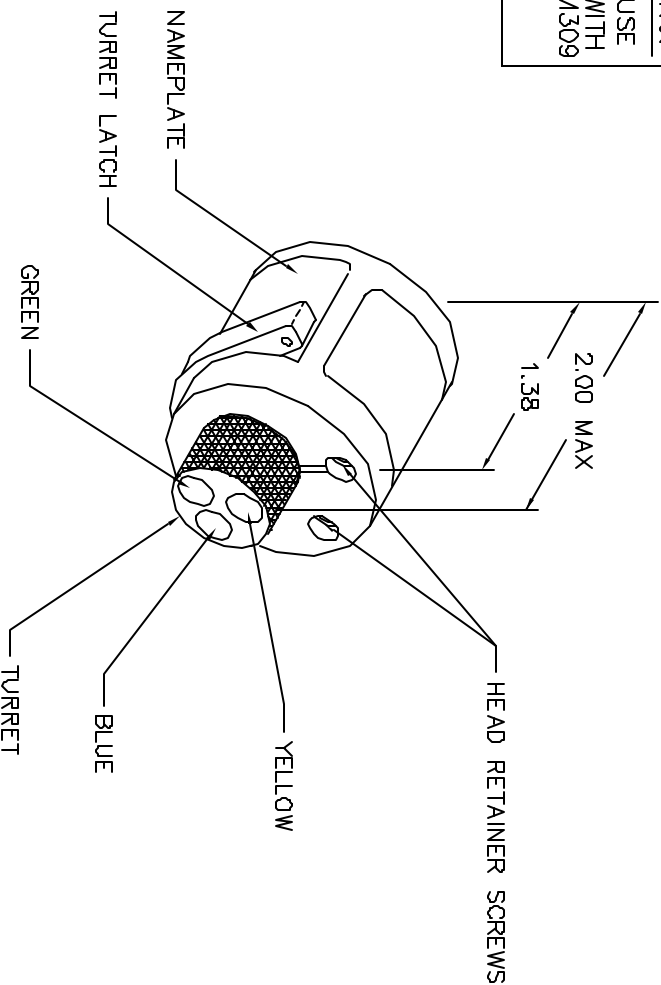

**UNCONTROLLED DOCUMENT
WILL NOT BE UPDATED**

RESTRICTED & CONFIDENTIAL
 PROPRIETARY PROPERTY OF DANIELS MANUFACTURING CORP. NOT TO BE REPRODUCED OR USED FOR ANY OTHER PURPOSE EXCEPT AS AUTHORIZED IN WRITING BY DANIELS MANUFACTURING. MUST BE RETURNED TO DANIELS MANUFACTURING CORP. ON COMPLETION OF ORDER OR OTHER PURPOSE FOR WHICH MADE.

| ITEM | PART NO. | QTY. | DESCRIPTION/REMARKS |
|--------|----------|------|---------------------|
| DRN | DATE | | |
| CHK'D | DATE | | |
| APPR'D | DATE | | |
| APPR'D | DATE | | |

NOTE: THIS DRAWING IS AN OUTLINE DRAWING OF THE RESPECTIVE DIM PART NUMBER. INDICATED ACTUAL DIM PART NUMBER WITHOUT THE "ENV" SUFFIX.

WHERE USED: M309

TITLE: ENVELOPE DRAWING
TURRET HEAD

DANIELS MANUFACTURING CORP.
DAWSON, FLORIDA
CHG# 17851

CD P/N: SH480-ENV
DIM. NO.: SH480-ENV

SHEET 1 OF 1
REV. 2

DO NOT SCALE DRAWING

Mouser Electronics

Authorized Distributor

Click to View Pricing, Inventory, Delivery & Lifecycle Information:

[Daniels Manufacturing:](#)

[SH480](#)