

| REVISIONS | | | | |
|-----------|---------------|------------------|-------------|-------------|
| REV. SYN. | E.C.G. NUMBER | DESCRIPTION | BY DATE | APP'D DATE |
| 1 | | ORIGINAL RELEASE | RRR 12/4/02 | RRR 12/4/02 |

"DO NOT CRIMP"
"GAGE"
"DANIELS-USA GB75"

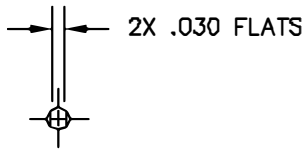

SECTION A-A

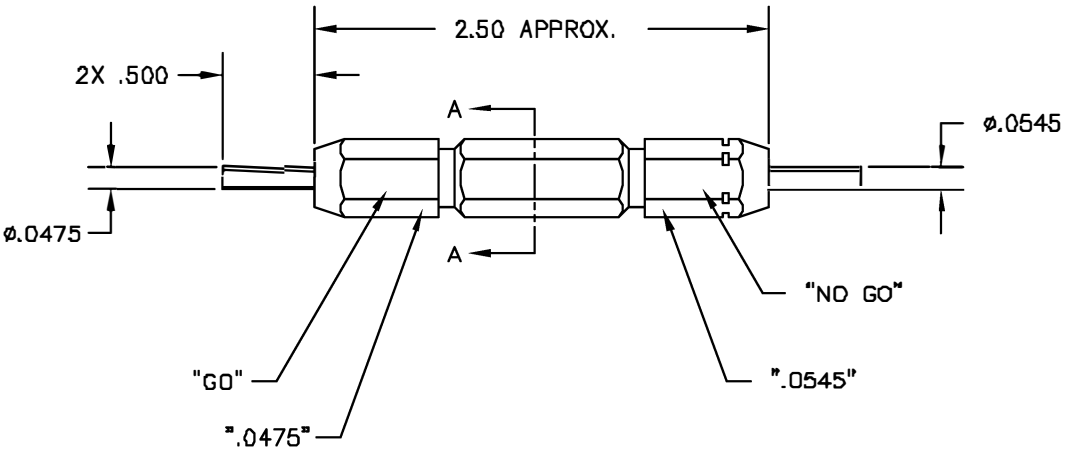

**UNCONTROLLED DOCUMENT
WILL NOT BE UPDATED**

| | | | | | |
|--|------------|-------------|----------|----------|--------------------------------|
| RESTRICTED & CONFIDENTIAL CONFIDENTIAL PROPERTY OF DANIELS MANUFACTURING CORP. NOT TO BE DISCLOSED TO OTHERS, REPRODUCED OR USED FOR ANY OTHER PURPOSE EXCEPT AS AUTHORIZED IN WRITING BY DANIELS MANUFACTURING. MUST BE RETURNED TO DANIELS MANUFACTURING CORP. ON COMPLETION OF ORDER OR OTHER PURPOSE FOR WHICH LENT. | MATERIAL | ITEM | PART NO. | QTY. | DESCRIPTION/REMARKS |
| | HEAT TREAT | DRN | J. JOYCE | DATE | 12/4/02 |
| | | CHKD | RRR | DATE | 12/4/02 |
| | FINISH | APPL | | DATE | |
| APPL | | | DATE | | |
| DO NOT SCALE DRAWING | | TITLE | | | GO/NO-GO GAGE ENVELOPE DRAWING |
| | | WHERE USED: | | | |
| | | SIZE | SCALE | CAD P/N | SHEET OF |
| | | B | NTS | G875-ENV | 1 1 |
| | | POSTING | P/N | G875-ENV | REV. 1 |

Mouser Electronics

Authorized Distributor

Click to View Pricing, Inventory, Delivery & Lifecycle Information:

[Daniels Manufacturing:](#)

[G875](#)