

DBS-2100 MANUAL BANDING TOOL FOR 1/4" STAMPED BUCKLE BANDS

SEE PAGE 20 FOR IMPORTANT INFORMATION CONCERNING LIMITED WARRANTY AND LIMITATION OF LIABILITY.

INTRODUCTION

The Daniels DBS-2100 (M81306/1A) Manual Banding tool is primarily designed for termination of EMI/RFI shielding materials. If there is a disagreement between the assembly process described herein and the connector/accessory supplier's instructions, or an OEM approved process, the latter document's shall have priority. Consult DMC for further information.

1.0 Tool Components and Operation Instructions

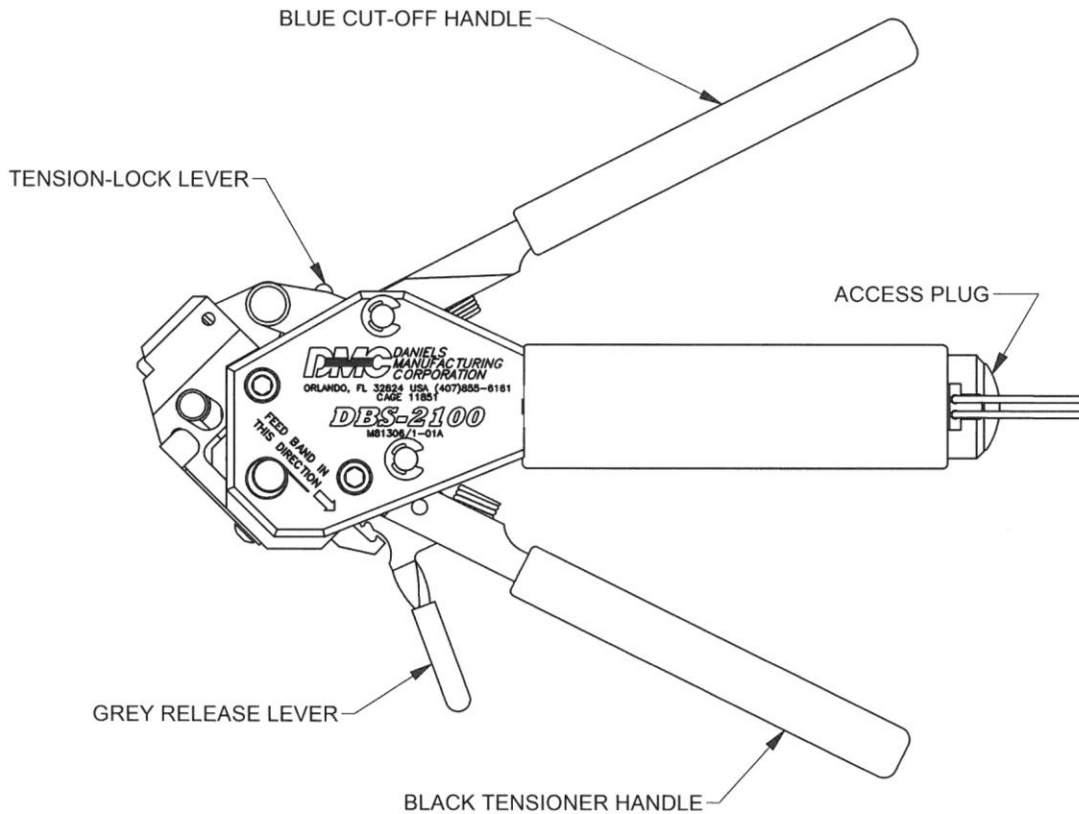

Step 1: Prepare the Connector and Cable Braid

Terminate wire/contact assemblies and insert them into the connector. Prepare the cable braid for band termination process (See section 2.0 on page 5).

Step 2: Prepare band

Using a ¼" stamped buckle band, feed the end of the band through the narrow slot on the buckle twice until the indicator mark is within approximately .250" of the buckle slot. This will create a double looped band. Never use a single looped band with the DBS-2100. To hasten the termination process on smaller adaptors, pull on the end of the band to reduce the diameter of the loop.

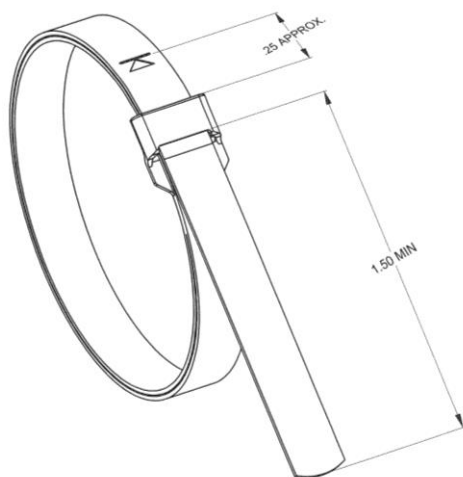

NOTICE

Application: For M85049/128-3 and -4 shield bands only. Do not use the DBS-2100 One Step Banding Tool on M85049/128-1 and -2 welded buckle bands.

Consult DMC for tool selection for other shield bands

Step 3: Insert looped band into tool

Squeeze the grey release lever on the DBS-2100 and insert the end of the band into the nose of the tool. Ensure the orientation of the band matches the graphic on the body of the tool.

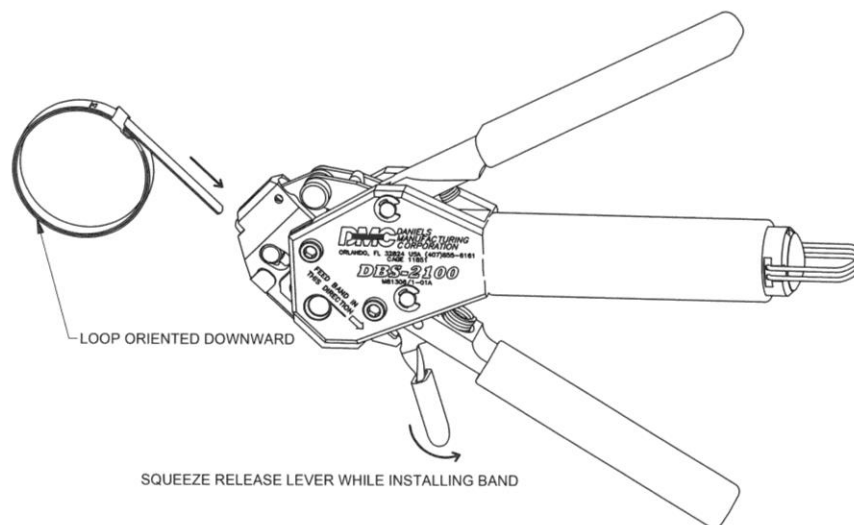

Step 4: Tighten Band around Braid/Connector

Repeatedly squeeze black tensioner handle until the band starts to tighten around the assembly. As the band tightens with each stroke of the tensioner handle, use abbreviated strokes (half strokes) until the band is tight against the braided cable. Release the tensioner handle and allow it to open fully. Confirm that the band is positioned flat over the braid on the connector accessory, and with one final stroke, close the tensioner handle until it locks against the tool body. This indicates that the band has been tightened to the pre-calibrated tension.

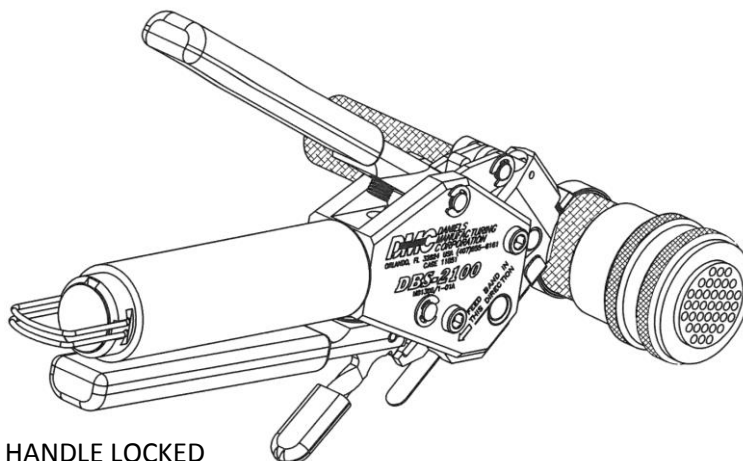

TENSIONER HANDLE LOCKED

The following instructions apply only if the band must be removed or repositioned.

To loosen or remove the looped band prior to locking the tensioner handle at the pre-calibrated tension, squeeze the release lever and pull the looped band away from the nose of the tool.

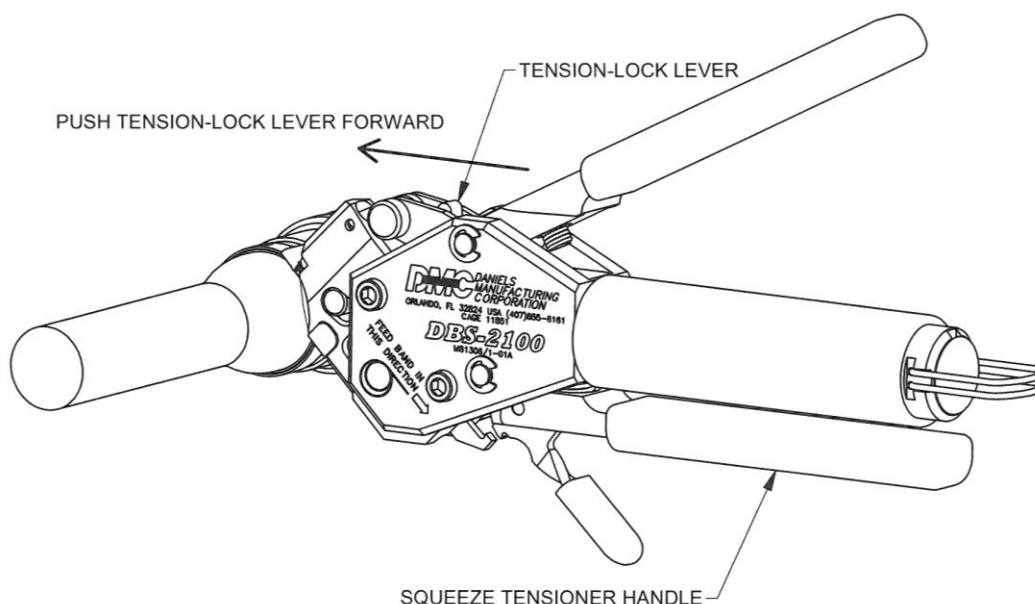

To loosen or remove the looped band after locking the tensioner handle at the pre-calibrated tension, squeeze the tensioner handle and push the tension-lock lever forward. While holding the tension-lock lever forward, release the tensioner handle. The tensioner handle will open fully. Squeeze the release lever and pull the looped band away from the nose of the tool.

Step 5: Cut off excess band material

Once the tensioner handle is locked in place, squeeze the blue cut-off handle to finish the termination process. Ensure that the connector assembly is free to rotate slightly during this cut-off step. Both handles will open up on their own when tension is released by the cut.

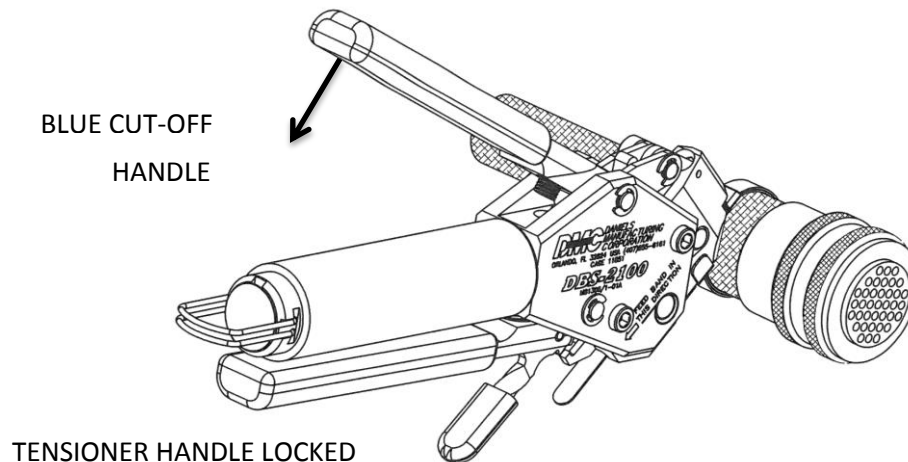

Step 6: Remove excess band material

Squeeze the grey release lever. While squeezing the release lever, carefully pull on the excess band material, and slide it out of the tool and discard.

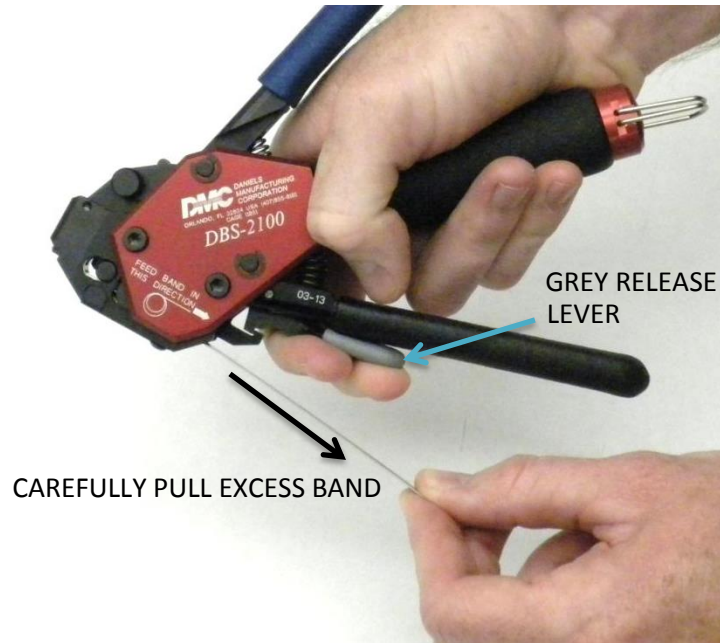

Step 7: Inspect the Termination

Visually inspect the termination made by the DBS-2100.

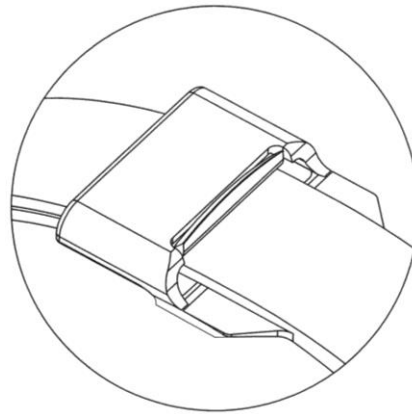

2.0 Wire Assembly Preparation and Termination Instructions

2.1 Procedure for installing the Band on the Cable Braid and Connector

Careful measurement should be made prior to installing the backshell. The outer jacket (if present) is then uniformly removed at a distance which would allow the braid to make a comfortable transition onto the backshell termination area. This dimension will vary depending upon the differences between cable and backshell diameters or other application dependent factors.

The braid is then trimmed to a length which will allow it to extend approximately 1 inch past the backshell termination platform. Then the braid is carefully folded rearward to expose the wires which will be inside the backshell.

The backshell is installed onto the connector, using a nonabrasive tool such as a strap wrench. The braid is then carefully moved from under the backshell. It is important to retain the woven characteristics of the braid during this step.

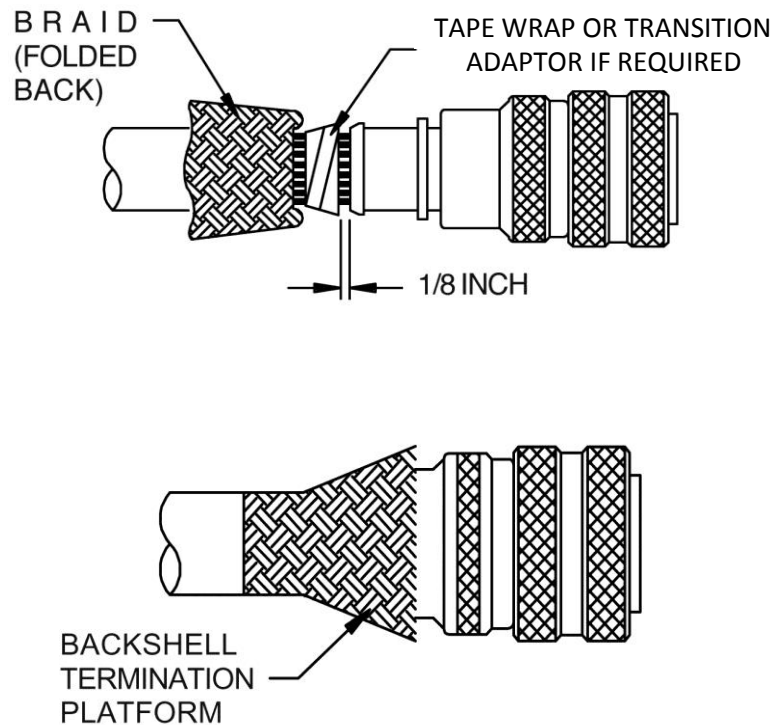

The braid is pushed into position over the backshell termination platform. Care must be taken to make sure the weave is uniform and no large “windows” are present. A shield termination band is loaded into the tool. If the band is uncurled it must be double looped through the buckle before termination. The band is then slid into a position of alignment with the backshell termination platform.

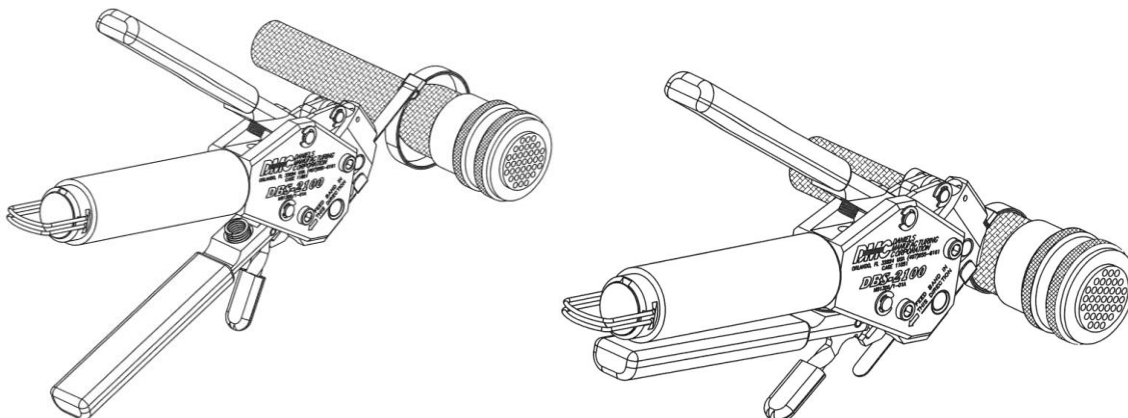

Apply an adequate amount of pressure in line with the cable as it enters the backshell to allow the 1/8 inch space to be reduced to zero. The tool is then activated to the preset tension, and terminated/cut using the procedure described in section 1.0 of this guide.

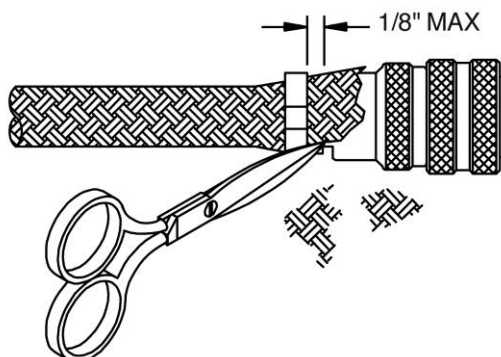

For braiding a non-jacket cable use fine point shears to trim the excess braid as close to the connector side of the bands as possible. Do not leave any unsecured braid wires longer than 1/8 inch. Do not allow the trimmed wires to fall in any areas where they may present a foreign object damage hazard. If a shrink boot or other covering is used, the excess braid may be folded back over the band.

2.2 Procedure for MID-CABLE Splicing

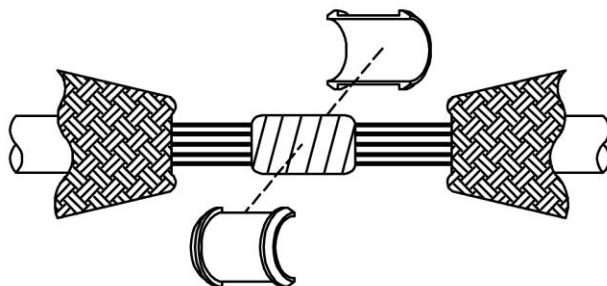

If the shield has been cut and separated to expose the wires requiring service and the required service has been completed, the wire bundle is then protected by a few wraps of self-vulcanizing tape followed by 2–3 layers of teflon tape. An appropriate size split-ring set is then selected and installed. One layer of teflon tape is applied over the split ring set to hold the halves in position while the next steps are being performed.

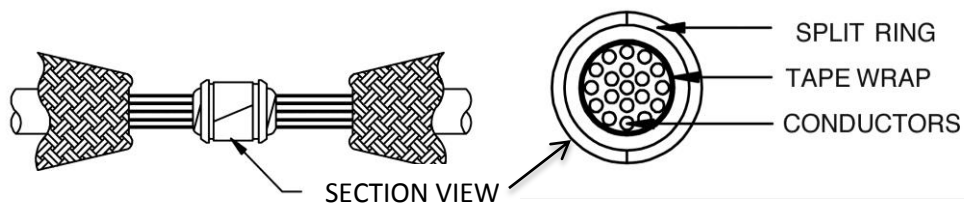

The braid is then overlapped across the split ring set. Be sure the braid ends protrude completely under the band in both directions.

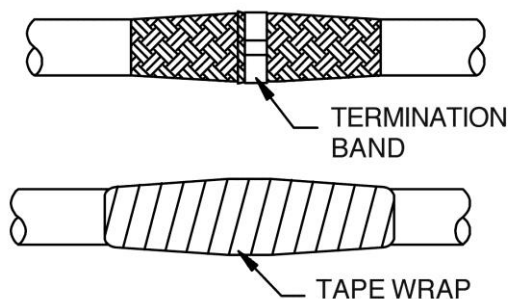

Heat-shrinkable tape is then applied over the splice. When a jacketed cable is used, be sure the tape extends onto the jacket in both directions.

3.0 BAND TENSION VERIFICATION

INTRODUCTION

The Daniels DBS-CG7 (M81306/1C) Verification Inspection Gage is designed for verifying the pre-set tension of the DBS-2100 manual banding tool. Consult DMC for further information.

Gage Components and Operation Instructions

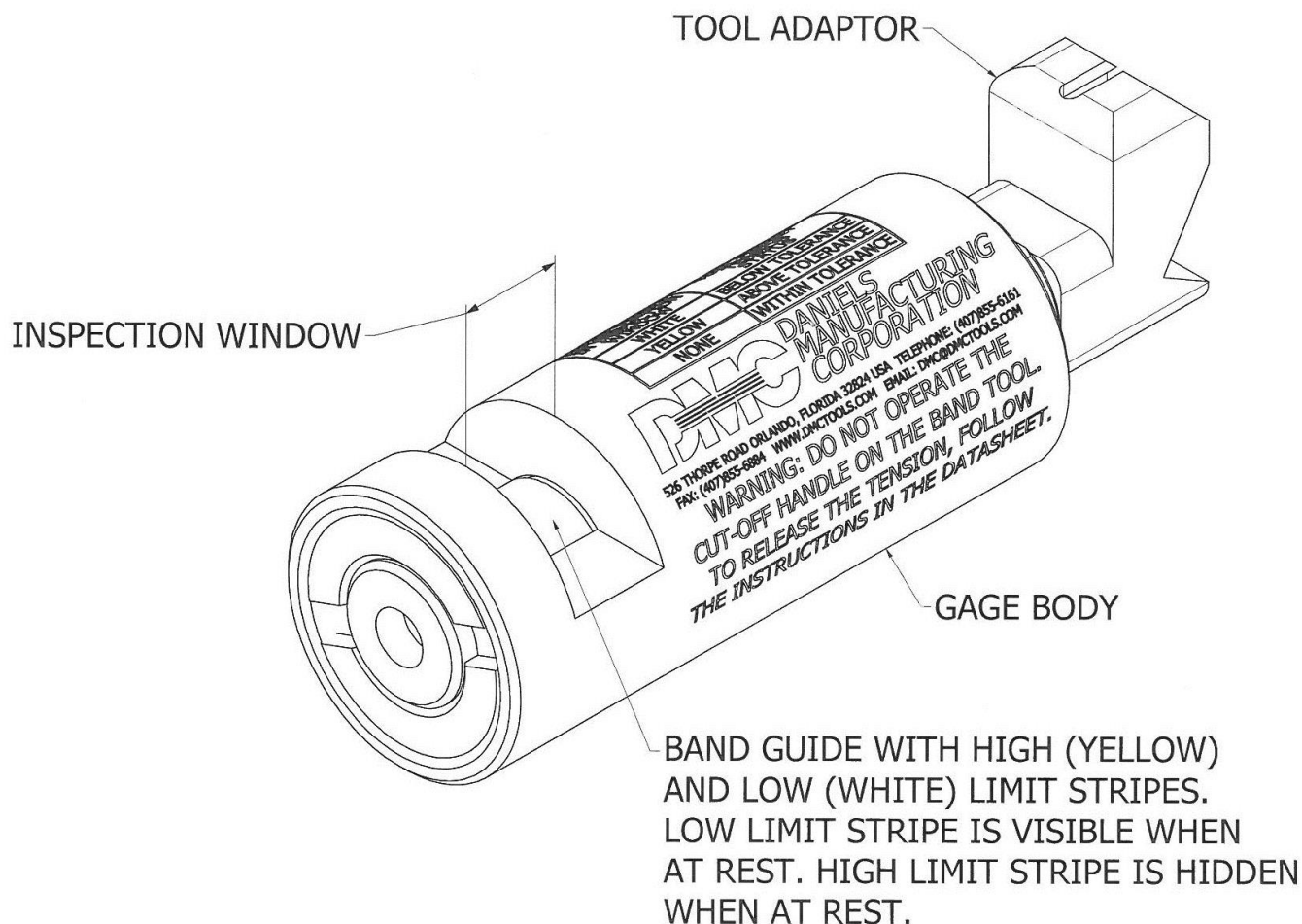

Warning: Keep the DBS-CG7 in a clean, dry place when not in use. Keep the inspection window free from dust and debris.

3.1 VERIFYING THE TENSION APPLIED TO THE BAND IS WITHIN 145-155 POUNDS.

Step 1: Insert the band into the DBS-CG7

Insert the flat end of a ¼" wide band through the hole in the DBS-CG7. Pass the band through the DBS-CG7 until the buckle comes into contact with the end of the verification inspection gage.

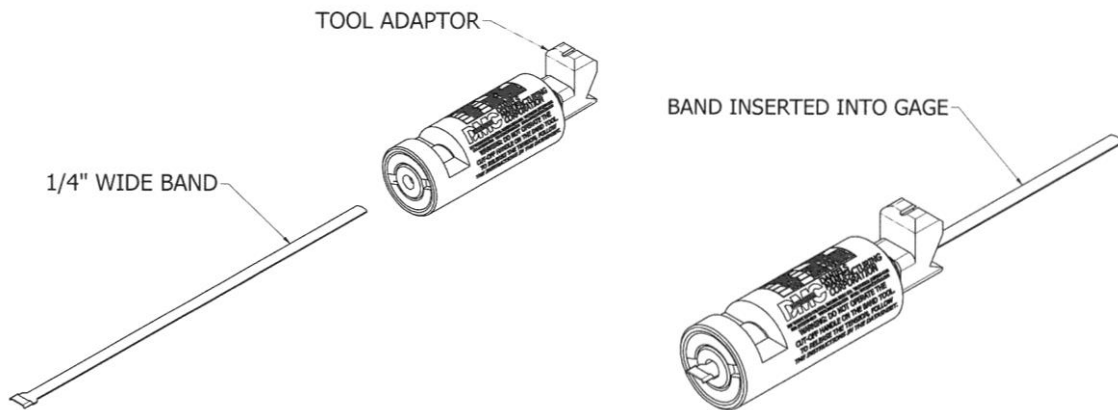

Step 2: Insert the end of the band into the DBS-2100

Squeeze the grey release lever and insert the flat end of the band through the nose of the DBS-2100 far enough for the tool's advancement pawl to engage the band (approx. 1.5"). The band may be inserted further into the tool to hasten the process.

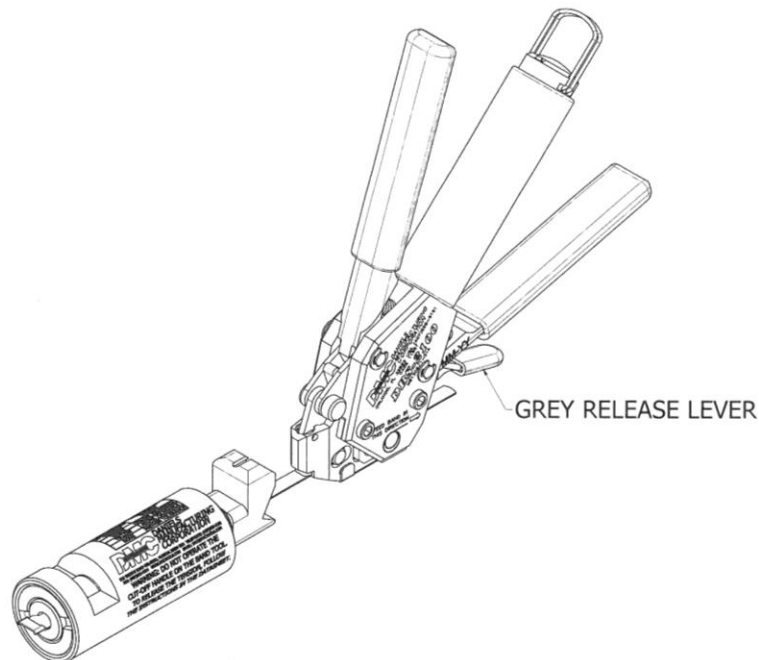

Step 3: Align the tool with the verification inspection gage

Align the tool's nose so that it butts up against the DBS-CG7 as shown below.

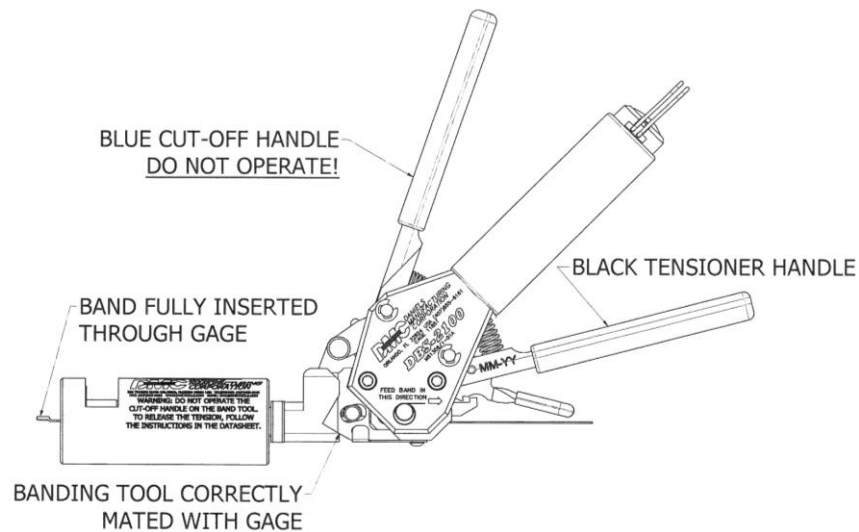

Step 4: Lock the black tensioner handle

While ensuring the tool and verification inspection gage stay in the mated position (as shown above), repeatedly squeeze the black tensioner handle until the tool and DBS-CG7 are firmly docked. Slowly squeeze the black tensioner handle three times using partial strokes. Allow the tensioner handle to open fully and with one final stroke, squeeze the tensioner handle until it is retained in the closed position by the internal latching mechanism.

Note: Rapid cycling of the tensioner handle may affect gaging.

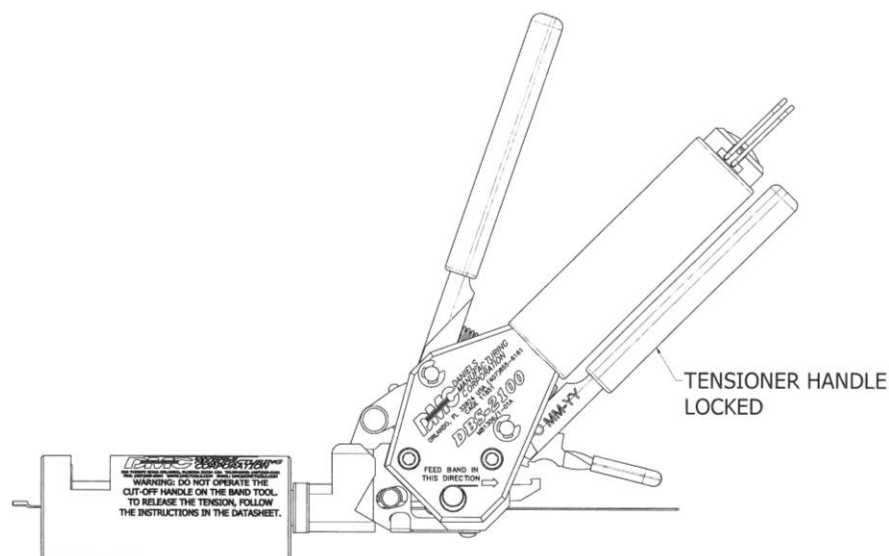

Step 5: Look for Limit Stripes in Inspection window

With the black tensioner handle locked, look into the Inspection Window. If any amount of the white stripe is visible, the tension applied to the band by the DBS-2100 is below 145LBS. This indicates that the tension setting for the DBS-2100 must be adjusted. (See section 3.2 for adjustment instructions.)

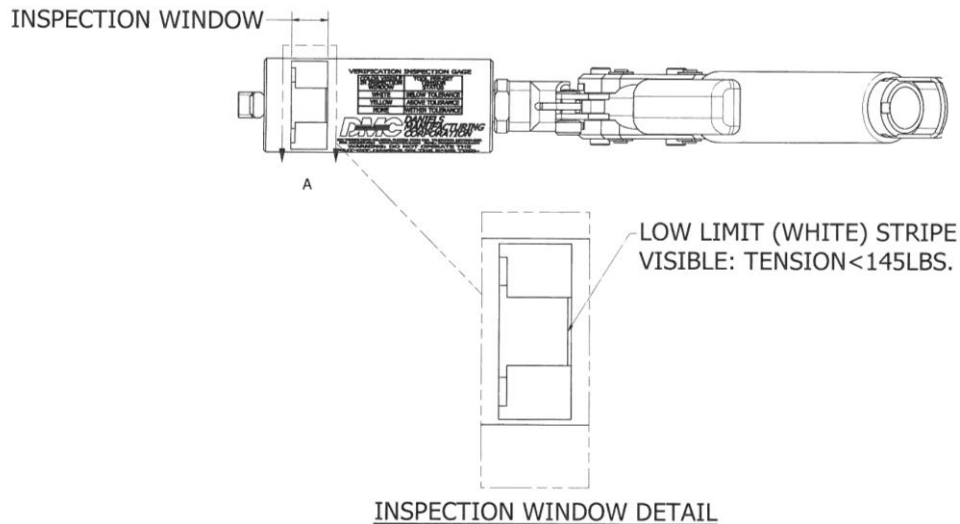

If no limit stripes are visible in the Inspection Window, the tension applied is between 145-155LBS. The Banding tool is within the acceptable range and does not require any adjustment.

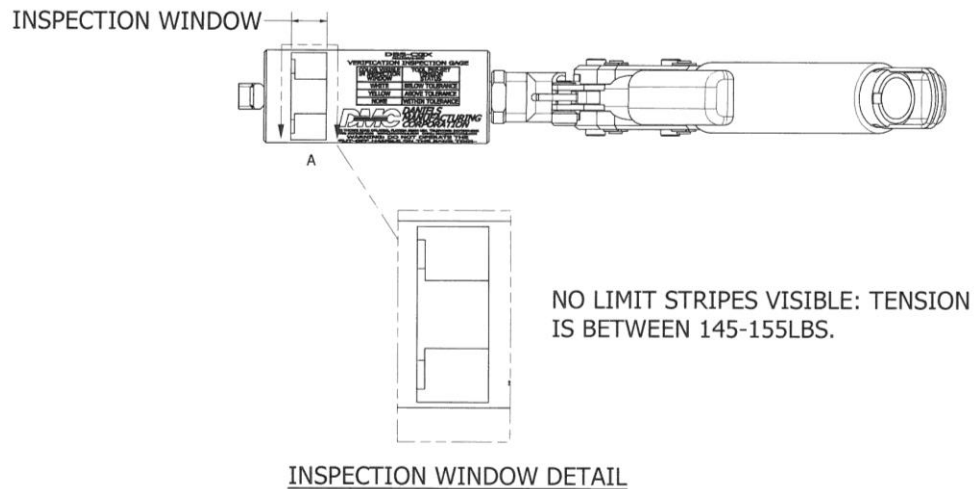

If any amount of the yellow stripe is visible, the tension applied to the band by the DBS-2100 is above 155LBS. This indicates that the tension setting for the DBS-2100 must be adjusted. (See section 3.2 for adjustment instructions.)

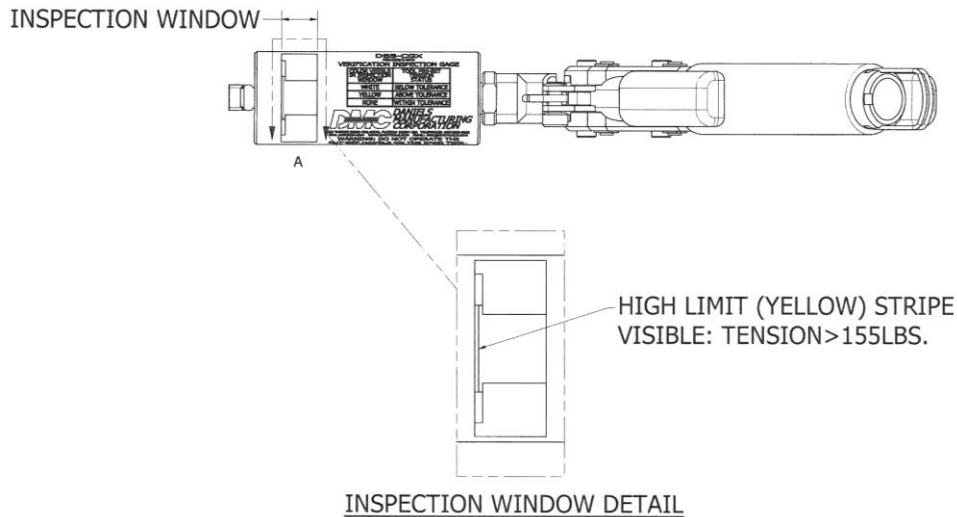

Step 6: Remove the tension on the band

Squeeze the black tensioner handle and push the tension-lock lever forward. While holding the tension-lock lever forward, release the black tensioner handle. The tensioner handle will open fully. Squeeze the grey release lever and pull the band and DBS-CG7 away from the nose of the tool. (See pages 3-4 for more details on releasing the tension on the band.)

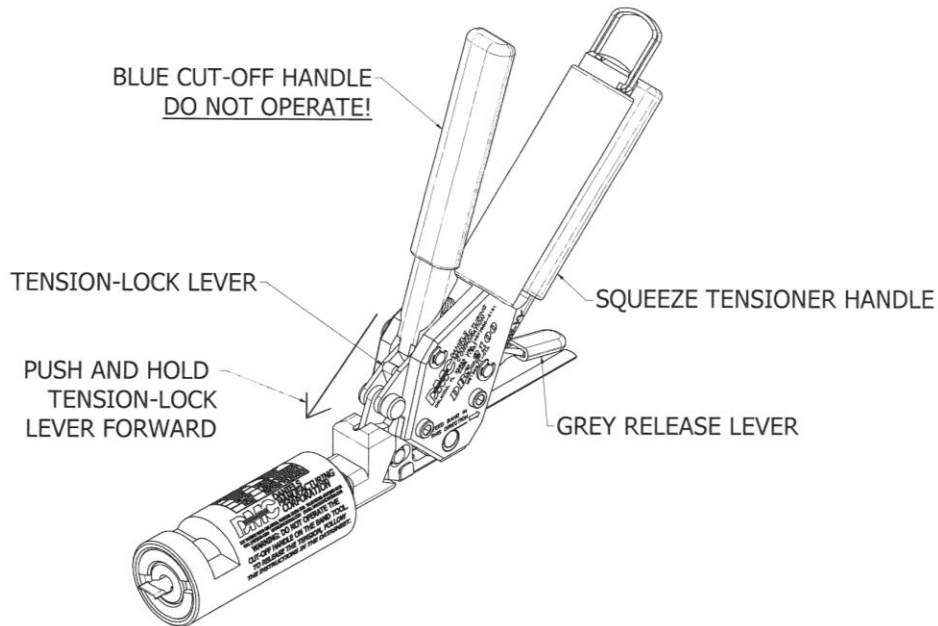

NOTE: DO NOT ATTEMPT TO CUT THE BAND. DAMAGE TO THE TOOL AND/OR GAGE MAY OCCUR.

3.2 ADJUSTING THE TENSION APPLIED BY THE TOOL

Step 1: Remove the access plug

With a flat head screwdriver or similar tool, pry the plastic access plug out of the rear end of the tool.

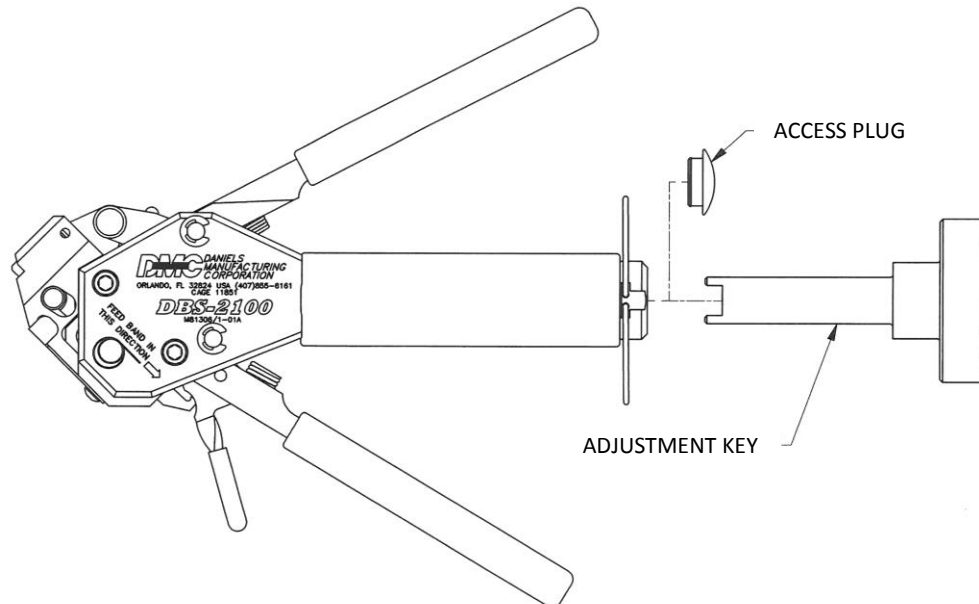

Step 2: Insert the adjustment key into the access hole

Insert the adjustment key (p/n DBS-2100-32) through the access hole and engage the key with the adjustment nut inside the tool.

Step 3: Adjust the spring preset

Turn the adjustment key either clockwise or counterclockwise in small increments ($1/4$ to $1/2$ turns) to change the tension that the tool will apply to the band during the termination process.

To INCREASE the tension, turn the adjustment key clockwise.

To DECREASE the tension, turn the key counterclockwise.

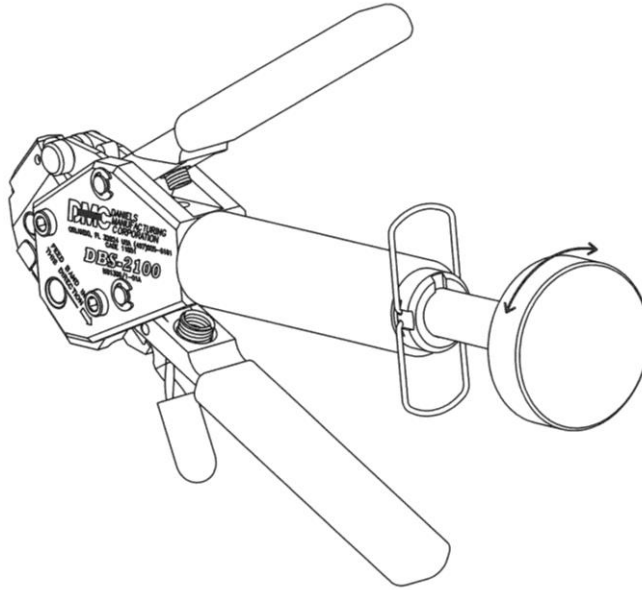

Step 4: Verify the tension applied to the band is within the specified tolerance

Follow Steps 1-5 in section 3.1 to verify that the tool is applying the appropriate tension to the band (145-155 pounds). If the tool requires further adjustment, follow steps 2-4 in this section. If the tool applies the appropriate tension, reinstall the access plug.

CAUTION: Do not rotate any components of the DBS-CG7. To do so will alter the factory set calibration. Factory service and recalibration of the DBS-CG7 is available.

4.0 BLADE REPLACEMENT PROCEDURE

Step 1: Familiarize yourself with the position and orientation of components

Refer to following illustration and take note of the orientation and location of the parts that are labeled.

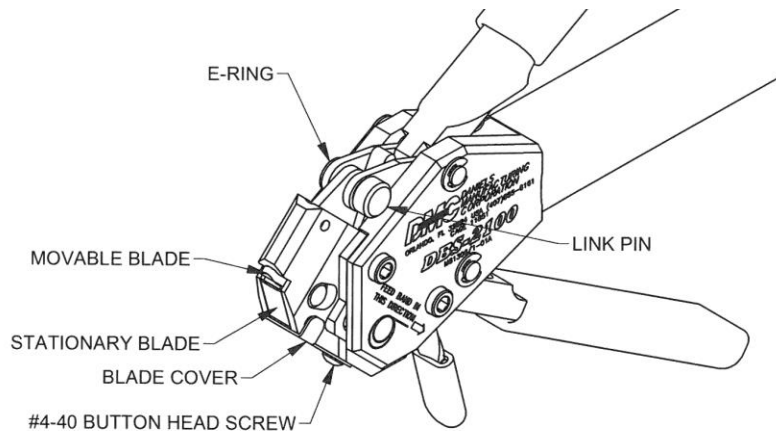

Step 2: Remove the stationary blade (DBS-2100-SB)

- Remove the #4-40 button head screw from the lower face of the tool, using a 1/16" Allen wrench.
- Remove the Blade Cover (DBS-2100-17) to expose the Stationary Blade's dowel pin.
- Push the dowel pin out from either side of the tool with a small drift punch.
- Slide the stationary blade out of the banding tool.
- If only replacing the stationary blade, install new blade by following the steps in reverse order. Ensure that the orientation of the blade is the same as it was originally.

Note: If changing both blades, leave the stationary blade off until the movable blade has been replaced.

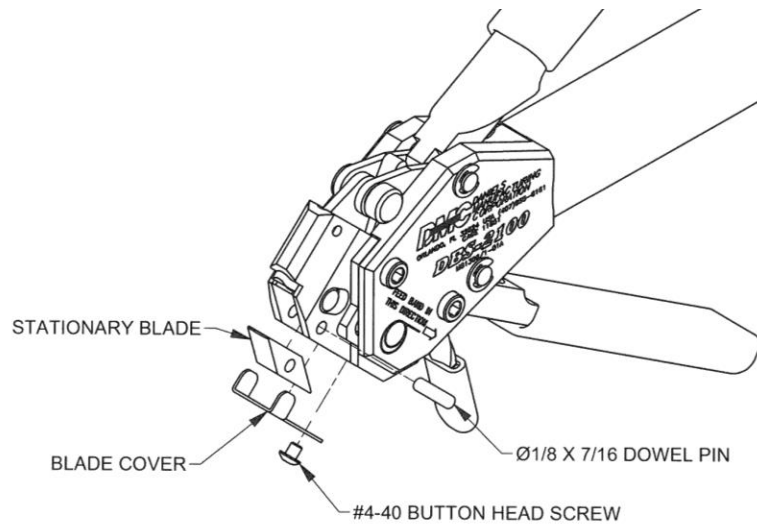

Step 3: Remove the movable blade (DBS-2100-MB)

- Stationary Blade must first be removed using the procedure in step 2.
- Wear safety glasses.
- Carefully remove the E-Ring from the Link Pin (DBS-2100-LP) with needle nose pliers.
- Pull Out the Link Pin.

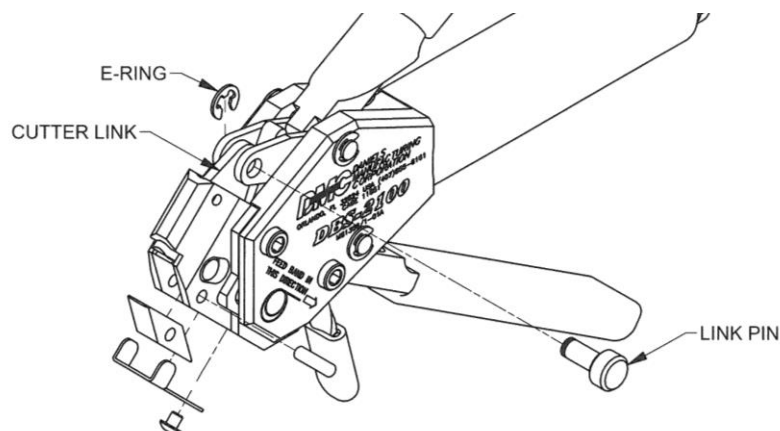

- Rotate Cutter Link so that the dowel pin becomes visible in the large access hole.

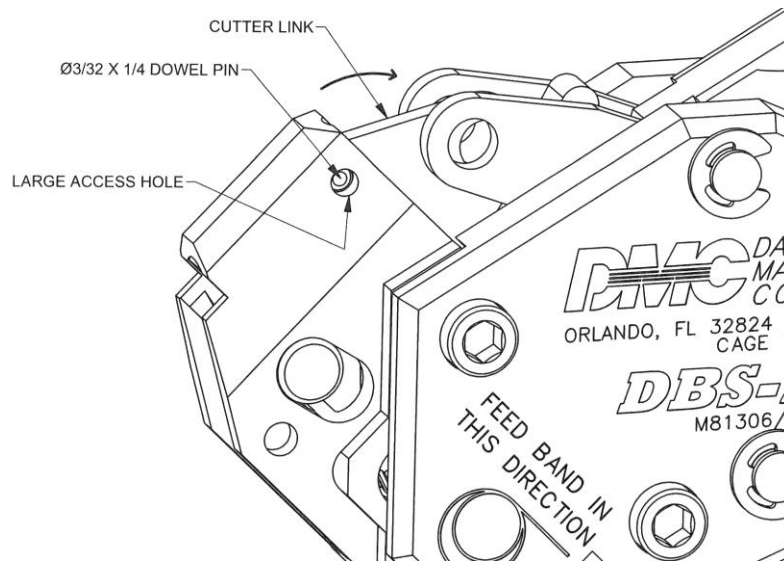

- Push the Dowel Pin through the large access hole by inserting a $\varnothing 1/16$ " drift punch through the smaller access hole on the reverse side of the tool.
- Remove the Movable Blade through the bottom of the tool. Take note of the orientation of the movable blade. It is critical that the movable blade be replaced in the same orientation (Chamfer facing towards nose of the tool, cutting edge facing inward).

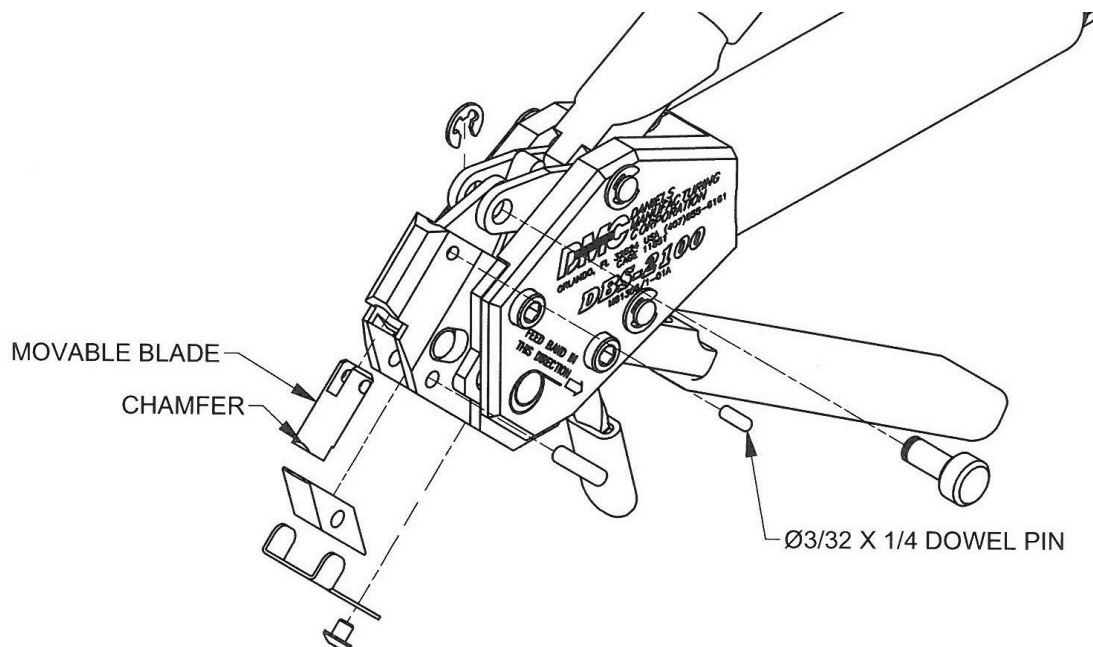

- To replace blades, reassemble in reverse order. Assemble the #4-40 button head screw with Loctite 242 or equivalent to prevent the screw from backing out during use.

5.0 FIELD REPLACEABLE COMPONENTS

FIELD REPLACEABLE COMPONENTS
FOR DBS-2100 BAND TOOL

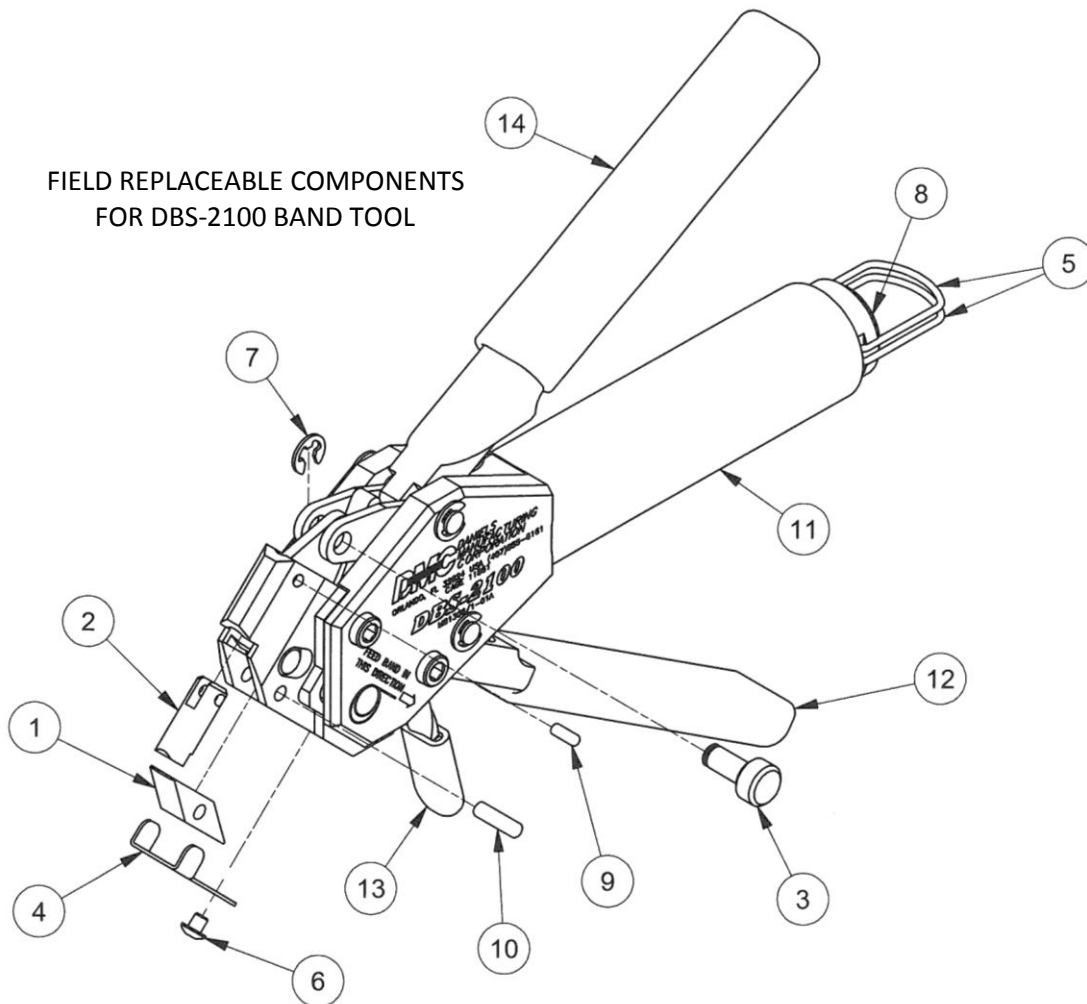

REPLACEABLE PARTS LIST

ITEM	PART NUMBER	QUANTITY	DESCRIPTION
1	DBS-2100-SB	1	STATIONARY BLADE
2	DBS-2100-MB	1	MOVABLE BLADE
3	DBS-2100-LP	1	LINK PIN
4	DBS-2100-17	1	BLADE COVER
5	DBS-2100-18	2	D-RING
6	1-1131	1	#4-40 X 1/8 BUTTON HEAD SCREW
7	4-1785	1	E-RING
8	4-1798	1	ACCESS PLUG
9	6-1001M	1	Ø3/32 X .240 DOWEL PIN
10	6-1065	1	Ø1/8 X 7/16 DOWEL PIN
11	7-1226	1	MAIN BODY BOOT (BLACK)
12	7-1227	1	TENSIONER HANDLE BOOT (BLACK)
13	7-1228	1	RELEASE LEVER BOOT (GREY)
14	7-1229	1	CUT-OFF HANDLE BOOT (BLUE)

Daniels Manufacturing Corporation offers complete refurbishing and recalibration services.

DMC specially engineers and manufactures complete tool kits to satisfy individual customer requirements, such as total aircraft support, general shop maintenance or production, on board ship and vehicle service, etc.

LIMITATION OF LIABILITY

Daniels Manufacturing Corporation is not liable for consequential or special damages of any nature or kind resulting from the use, or misuse, of any of its products. Owners and users of DMC products assume full responsibility for instructing their employees in the proper and safe use of such products.

LIMITED WARRANTY

DMC (Daniels Manufacturing Corporation) warrants each new product sold by it to be free from defects in material and workmanship under normal use and service. DMC's obligation under this warranty is limited to the free correction or, at DMC's option, the refund of the purchase price of any such product which proves defective in normal service within ninety (90) days after delivery to the first user, provided that the product is returned to DMC with transportation charges prepaid and which shall appear to DMC's satisfaction, it being understood that DMC products are not consumer products. This warranty shall not cover any damage to any product which, in the opinion of DMC, was caused by normal wear, misuse, improper operation, tampering, neglect or accident. This warranty is in lieu of all other warranties express or implied. No warranty, express or implied, is made or authorized to be made or assumed with respect to products of Daniels Manufacturing Corporation other than those herein set forth.

Mouser Electronics

Authorized Distributor

Click to View Pricing, Inventory, Delivery & Lifecycle Information:

[Daniels Manufacturing:](#)

[DBS-2100GA](#)