

QPO-1-EVAL1

QPO™ Active Output Filter Evaluation Board



Contents	Page
Introduction	1
Features	1
QPO-1-EVAL1 BOM	3
Installed Components	3
User Defined Components	3
Function Descriptions	4
Slope Adjust	4
Headroom Adjust	4
SC Function	4
Remote Sense	4
Start-up Circuit	6
Peak Detector	6
Ordering Information	8

Introduction

The QPO-1-EVAL1 is designed to allow full testing of the QPO-1LZ, along with its various performance options, to fully optimize a final system design. The board offers two terminal options for vertical or horizontal mounting. The user must select the required values for the RHR, RSCSET and RSA resistors and solder them in the designated positions before applying power to the EVAL1. Please refer to the QPO-1LZ product data sheet, schematics and the following pages for the proper application of this board.

The QPO-1 output ripple attenuator SiP uses active filtering to reduce output ripple and noise (PARD) over 30dB from 500Hz to 500kHz and can be extended down to 50Hz with additional capacitance added to the VREF pin. The QPO-1LZ operates over a voltage range from 3 to 30V_{DC} and supports load currents as high as 10A. Output regulation is maintained with remote sense or trim adjustment of the power supply. The closed loop architecture improves transient response and ensures quiet point-of-load regulation when used in conjunction with the power supply's control loop or trim node.

Features

- > 30dB PARD attenuation, 1 – 500kHz
- 3 – 30V_{DC} operating range
- 10A rating
- Supports precise point-of-load regulation through use of remote sensing or converter trimming
- Optional start-up circuit included
- User-selectable performance optimization for attenuation, power dissipation and transient response
- Horizontal or vertical mounting options
- Evaluation board includes a Johnson Jack for low-noise measurement of the QPO's filtering performance

Figure 1

Top view of evaluation board

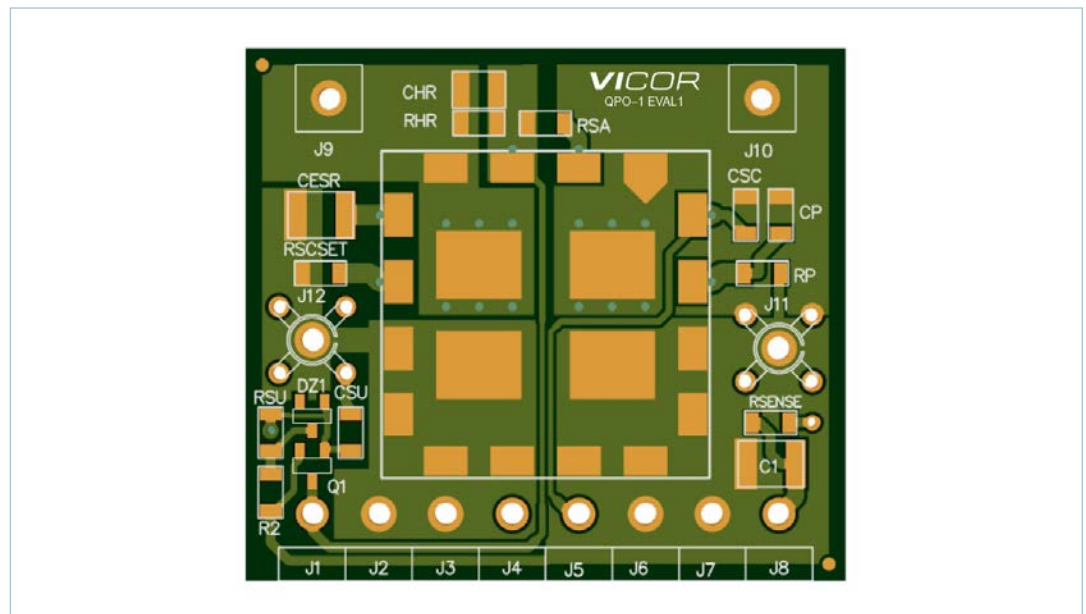

QPO-1 Performance

The waveforms in Figure 2 highlight the QPO-1's ability to both filter a converter's output ripple and maintain a constant output voltage during a load transient. The input voltage of the QPO-1 (dark blue) shows varying amplitude and frequency PARD before and during the load transient, but the QPO-1 output voltage (light blue) remains relatively unaffected. The load transient is a 1 – 10A load step (green).

The converter used is a Vicor Mini, 48V to 5V converter (Model number: V48B5C200BN).

Figure 2
PARD and Transient Attenuation

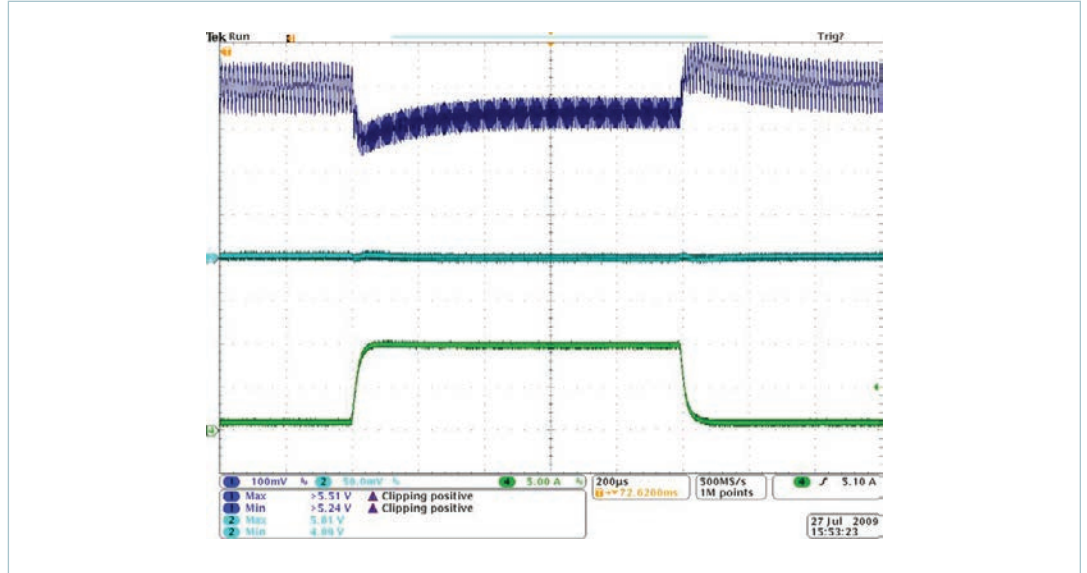
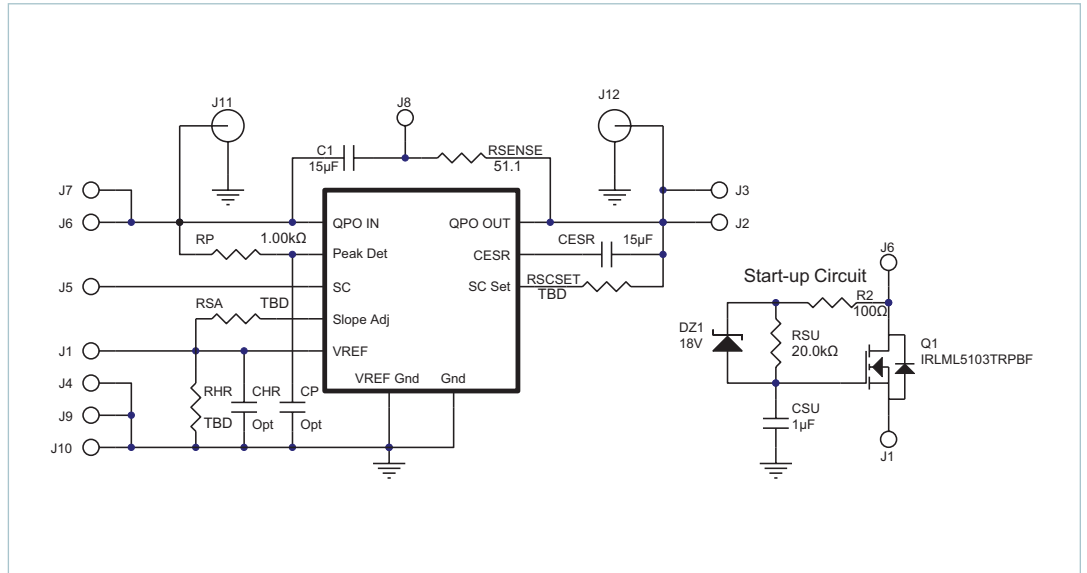

Figure 3
Evaluation board schematic



QPO-1-EVAL1 BOM

Qty	Description	Value	Designator	Vendor	Vendor Part Number
2	Capacitor, X7R eramic, 15µF, 25V, 1812	15µF	C1, CESR	TDK	C4532X7R1E156MT
1	Capacitor, X7R Ceramic, 1µF, 50V, 1206	1µF	CSU	TDK	C3216X7R1H105K
1	Diode, Zener, 12V, 0.15W, SOT-23	18V	DZ1	ON Semi	BZX84C18LT1G
8	Samtec, 0.2in, Rt-Angle Header		J1, J2, J3, J4, J5, J6, J7, J8	Samtec	FWS-08-02-T-S-RA
2	Connector, Johnson Jack	Johnson Jack	J11, J12	Tektronix	131503100
1	Transistor, PFET, 30V, 0.6A	RLML5103TRPBF	Q1	International Rectifier	IRLML5103TRPBF ^F
1	QPO-1LZ	QPO-1LZ	QPO-1	VICOR	QPO-1LZ
1	Resistor, 5%, 0.25W, 1206	100	R2	Rohm	MCR18EZPJ101
1	Resistor, 5%, 0.25W, 1206	1.00kΩ	RP	Rohm	MCR18EZHF1001
1	Resistor, 5%, 0.25W, 1206	51.1	RSENSE	Rohm	MCR18EZPF51R1
1	Resistor, 1%, 0.25W, 1206	20kΩ	RSU	Rohm	MCR18EZHF2002

Installed Components

The QPO-1-EVAL1 board comes with the following components pre-stuffed:

Remote Sense Components	C1, RSENSE
Start-up Assist Circuit	CSU, RSU, DZ1, R2, Q1
Peak Detector	RP
CESR	CESR

User-Defined Components

The QPO-1-EVAL1 board comes with the following components not installed; values to be determined by customer:

Headroom Resistor	RHR (not optional, must be installed for proper operation)
Headroom Capacitor	CHR (optional)
Slope Adjust	RSA (optional)
SC Function	CSC, RSCSET (optional)
Peak Detector	CP (optional)

Function Descriptions

Slope Adjust

The slope adjust function allows the user to modify the voltage drop across the QPO-1 (headroom voltage) dependent on the current passing through the QPO-1. This function is used to maintain a constant power across the QPO-1 over a varying range of load currents. The RSA resistor can be calculated by using the following equation:

$$R_{SA} = \frac{0.05V}{A} \cdot \frac{\Delta I_{OUT}}{\Delta V_{HR}} \cdot 2.5k\Omega \quad (1)$$

Where:

ΔI_{OUT} = Maximum change in load current (A)

ΔV_{HR} = headroom voltage change over load range (V)

R_{SA} = slope adjust resistor (Ω)

The slope adjust feature can be disabled by either using a large resistor value (100k Ω or greater) for R_{SA} or by omitting this resistor entirely.

Headroom Adjust

The RHR resistor is used to program the desired voltage drop across the QPO-1. This voltage must be greater than the ripple voltage that the QPO-1 is to filter, with additional voltage added for the voltage drops in the attenuation path. Like the RP resistor, the RHR resistor must always be installed for proper operation. The value of R_{HR} can be calculated using this equation:

$$R_{HR} = \frac{QPO_{OUT} \cdot 2.5k\Omega}{V_{HR}} \quad (2)$$

Where:

R_{HR} = headroom setting resistor value (Ω)

QPO_{OUT} = the voltage on the QPO's output (V)

V_{HR} = the target headroom voltage (V)

If this resistor is omitted, then the reference pin will be at the same voltage as the input pin, forcing the output pin to be the same voltage as the input pin.

SC Function

The function of the SC circuit is to use a converter's trim or SC (secondary control) pin to compensate for the voltage drop across the QPO-1, thereby maintaining the desired output voltage on the QPO's output.

The RSCSET resistor (listed as RSC in the data sheet) determines the amount of current the SC pin of the QPO-1 will source. The current is calculated by dividing the headroom voltage (the voltage drop from QPO_{IN} to QPO_{OUT}) by R_{SCSET} .

$$R_{SCSET} = \frac{R_{IN} \cdot V_{OUT}}{V_{RPT}} \quad (3)$$

Where:

V_{OUT} = nominal converter output voltage (V)

V_{RPT} = internal reference voltage (V)

R_{IN} = internal series resistor (Ω)

When using one of the Vicor Micro, Mini or Maxi converters, the $R_{IN} = 1k\Omega$ and the $V_{RPT} = 1.23V$.

Figure 4 shows the QPO-1-EVAL1 board connected so as to use the SC function to compensate for the QPO-1's voltage drop.

Remote Sense

Compensation for the QPO-1's voltage drop can be done using the converter's remote-sense pins, if available. The on-board sensing network can be attached as is shown in Figure 5.

Figure 4
Evaluation board in
SC configuration

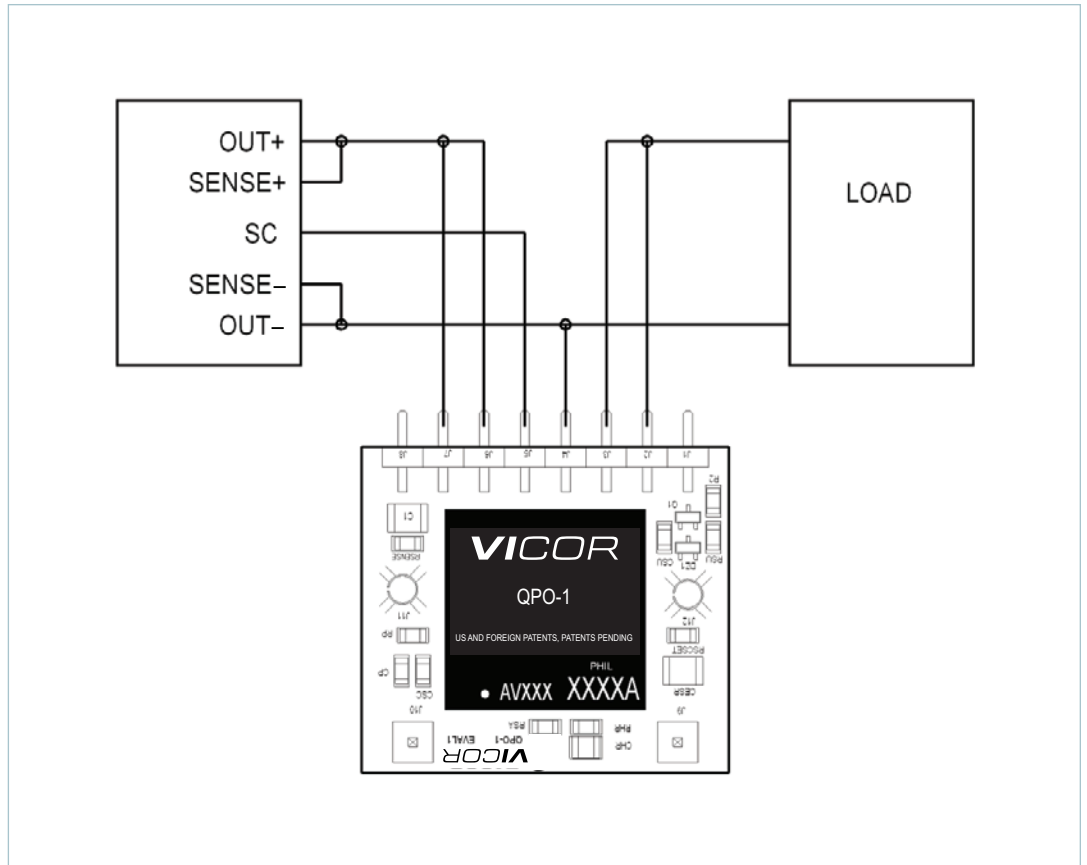

Figure 5
Evaluation board in
remote-sense configuration

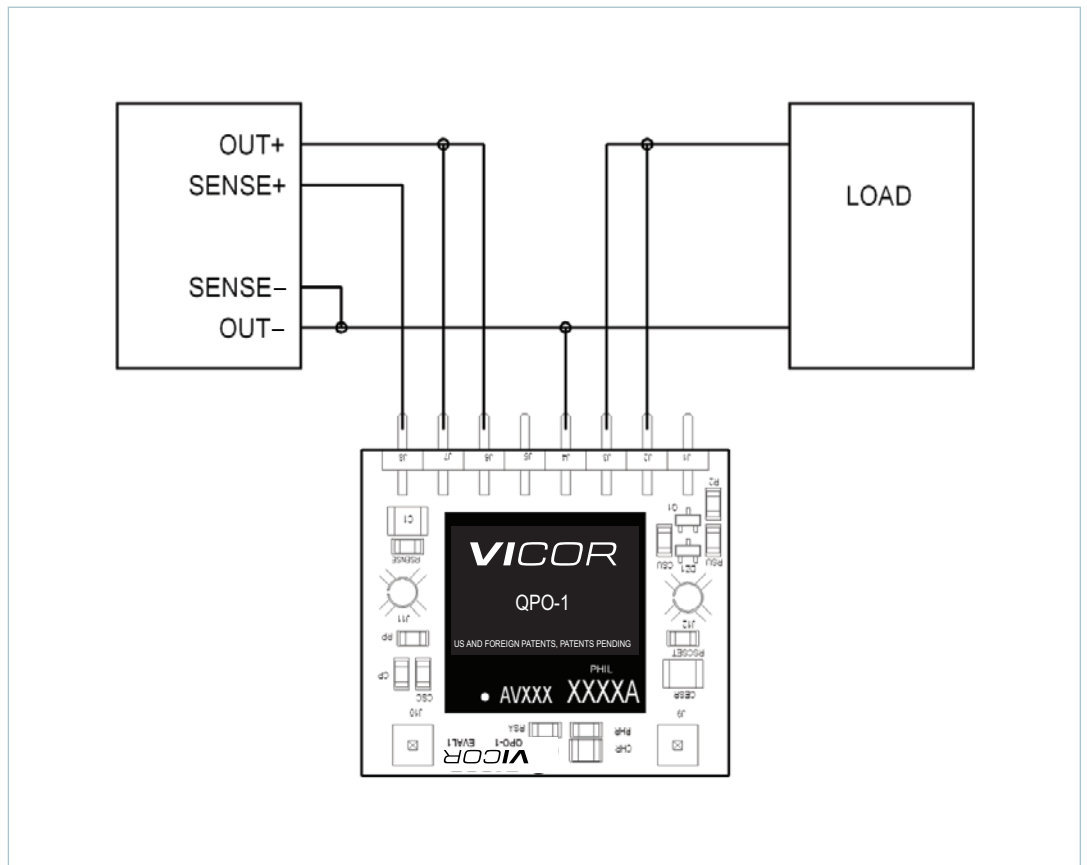
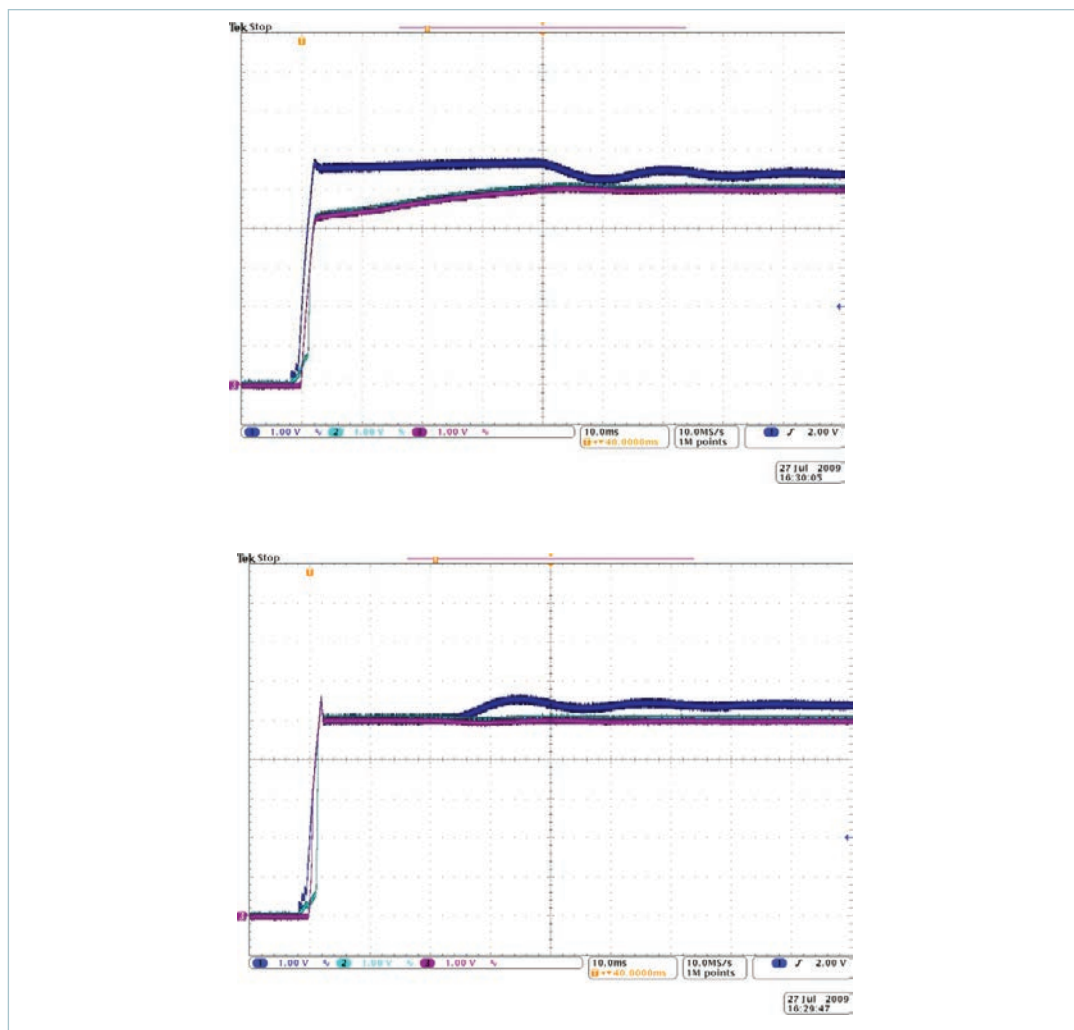

Figure 6
Start-up waveforms; without (top) and with (bottom) the optional start-up circuit



Start-up Circuit

The start-up circuit (Figure 3) on the evaluation board is used to connect the QPO-1's reference pin to its input pin during start up. In both waveform pictures of Figure 6, the Output Voltage (light blue) follows the V_{REF} voltage (purple) of the QPO-1.

In the picture on the top in Figure 6, without the optional start-up circuit, the QPO-1 input voltage (the converter's output voltage) can be seen to be greater than the nominal 5V output of the converter. This is due to the QPO-1's SC circuit having greater headroom voltage during start up and therefore over-driving the SC of the converter. After about 40ms, the V_{REF} voltage reaches its 5V pre-set limit and the converter's output voltage starts to drop, eventually steadying out at 5.35V, the nominal output voltage plus the QPO-1's headroom voltage.

The potential problem with this start up is that the converter could fault due to its output being forced to be greater than 110% of the nominal value. For converters with lower nominal output voltages, this could be very serious condition.

The waveforms on the bottom are the same converter with the optional start-up circuit enabled. Here, the V_{REF} is forced to follow V_{IN} , so V_{OUT} follows as well. After about 25ms, the start-up circuit releases the V_{REF} pin and it adjusts its value down to generate the proper headroom voltage across the QPO-1. Using this method, there is no possibility of over-driving the converter and causing a fault.

Peak Detector

The QPO-1 peak detector is used to adapt the headroom voltage in response to increasing converter ripple. The greater the ripple on the QPO-1's input, the greater the headroom voltage across the QPO-1. This feature can be disabled by adding the CP capacitor to the evaluation board. The addition of this capacitor creates an RC filter network that filters out the converter's ripple to the peak detector.

The RP resistor must always be installed for proper operation. The peak detector creates the internal reference voltage rail that gets divided down by the headroom resistor RHR.

Figure 7
Mounting options

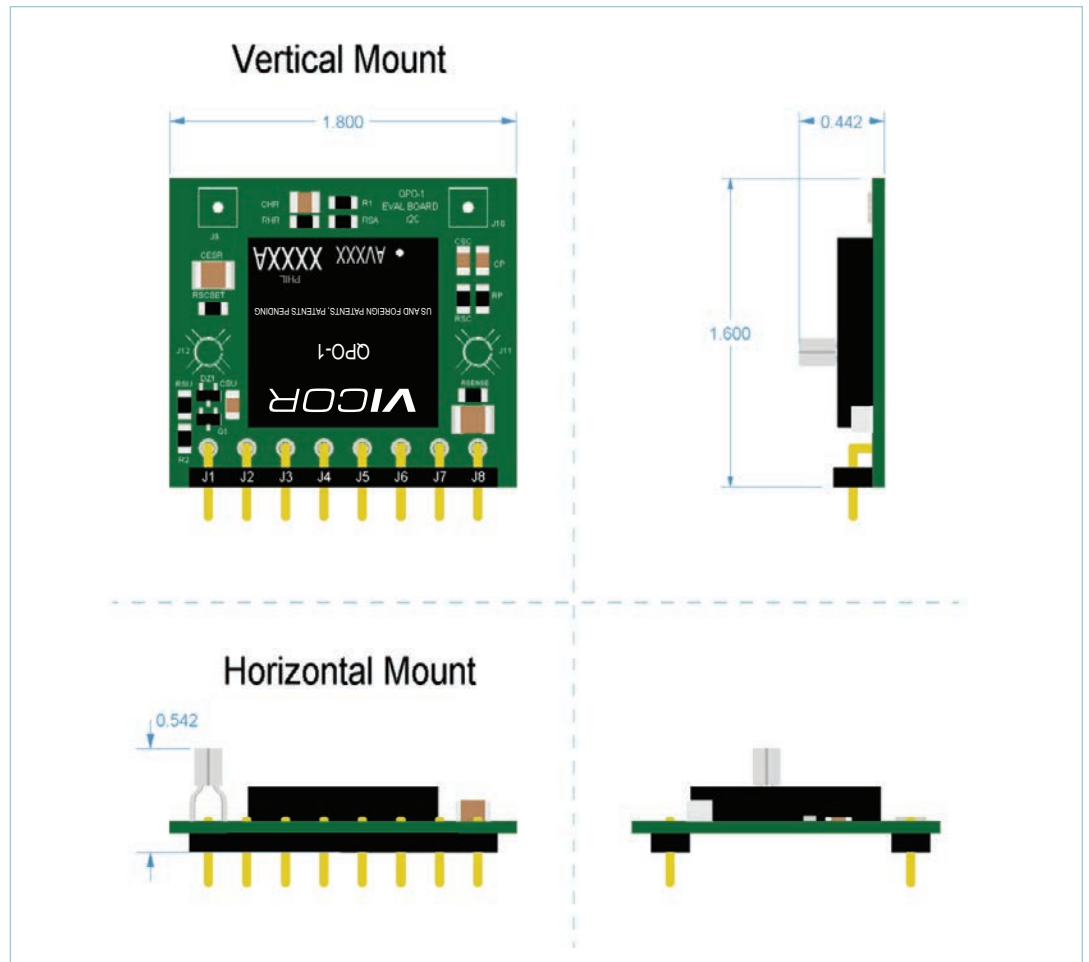
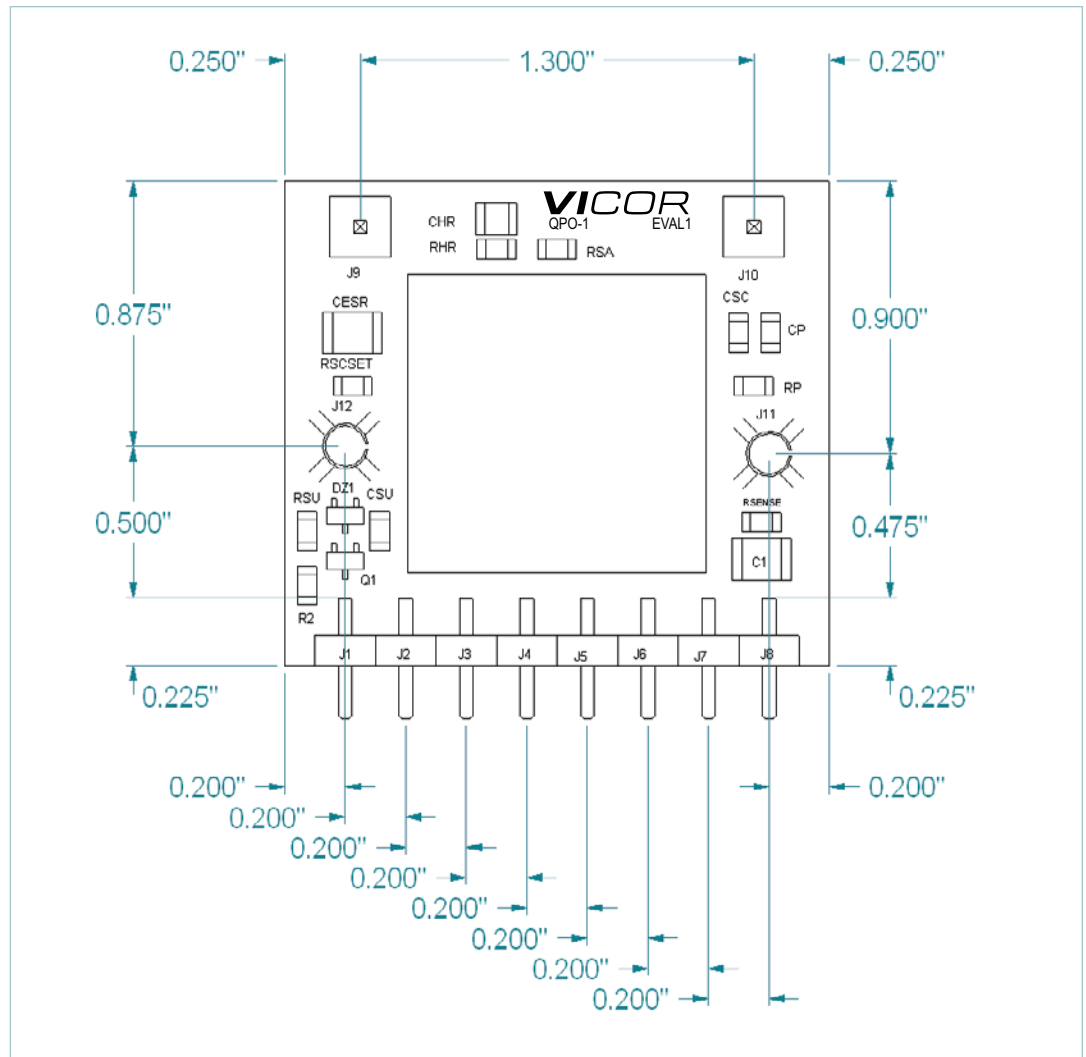

Figure 8
Mechanical drawing



Ordering Information

Carrier Board Part Number	Compatible VI Chip® Evaluation Boards (sold separately) ^[b]
QPO-1-EVAL1	Evaluation Board for QPO-1L

Limitation of Warranties

Information in this document is believed to be accurate and reliable. HOWEVER, THIS INFORMATION IS PROVIDED "AS IS" AND WITHOUT ANY WARRANTIES, EXPRESSED OR IMPLIED, AS TO THE ACCURACY OR COMPLETENESS OF SUCH INFORMATION. VICOR SHALL HAVE NO LIABILITY FOR THE CONSEQUENCES OF USE OF SUCH INFORMATION. IN NO EVENT SHALL VICOR BE LIABLE FOR ANY INDIRECT, INCIDENTAL, PUNITIVE, SPECIAL OR CONSEQUENTIAL DAMAGES (INCLUDING, WITHOUT LIMITATION, LOST PROFITS OR SAVINGS, BUSINESS INTERRUPTION, COSTS RELATED TO THE REMOVAL OR REPLACEMENT OF ANY PRODUCTS OR REWORK CHARGES).

Vicor reserves the right to make changes to information published in this document, at any time and without notice. You should verify that this document and information is current. This document supersedes and replaces all prior versions of this publication.

All guidance and content herein are for illustrative purposes only. Vicor makes no representation or warranty that the products and/or services described herein will be suitable for the specified use without further testing or modification. You are responsible for the design and operation of your applications and products using Vicor products, and Vicor accepts no liability for any assistance with applications or customer product design. It is your sole responsibility to determine whether the Vicor product is suitable and fit for your applications and products, and to implement adequate design, testing and operating safeguards for your planned application(s) and use(s).

VICOR PRODUCTS ARE NOT DESIGNED, AUTHORIZED OR WARRANTED FOR USE IN LIFE SUPPORT, LIFE-CRITICAL OR SAFETY-CRITICAL SYSTEMS OR EQUIPMENT. VICOR PRODUCTS ARE NOT CERTIFIED TO MEET ISO 13485 FOR USE IN MEDICAL EQUIPMENT NOR ISO/TS16949 FOR USE IN AUTOMOTIVE APPLICATIONS OR OTHER SIMILAR MEDICAL AND AUTOMOTIVE STANDARDS. VICOR DISCLAIMS ANY AND ALL LIABILITY FOR INCLUSION AND/OR USE OF VICOR PRODUCTS IN SUCH EQUIPMENT OR APPLICATIONS AND THEREFORE SUCH INCLUSION AND/OR USE IS AT YOUR OWN RISK.

Terms of Sale

The purchase and sale of Vicor products is subject to the Vicor Corporation Terms and Conditions of Sale which are available at: (<http://www.vicorpower.com/termsconditionswarranty>)

Export Control

This document as well as the item(s) described herein may be subject to export control regulations. Export may require a prior authorization from U.S. export authorities.

Contact Us: <http://www.vicorpower.com/contact-us>

Vicor Corporation
25 Frontage Road
Andover, MA, USA 01810
Tel: 800-735-6200
Fax: 978-475-6715
www.vicorpower.com

email

Customer Service: custserv@vicorpower.com
Technical Support: apps@vicorpower.com

Mouser Electronics

Authorized Distributor

Click to View Pricing, Inventory, Delivery & Lifecycle Information:

[Vicor:](#)

[QPO-1-EVAL1](#)