

ASCKCx00-xxxxx0x0x02

1608 DFN-2 Surface-Mount LED



Overview

The Broadcom[®] ASCKCx00 surface-mount LEDs utilize AlInGaP and InGaN chips in a small form factor DFN-2 package. The LEDs are designed with high-reliability performance to work under a wide range of environmental conditions. The small form factor package enables flexibilities in product designs. The LEDs are ideal for a wide range of applications.

To facilitate easy pick-and-place assembly, the LEDs are packed in tape and reel. Every reel is shipped in single intensity and color bin, to provide close uniformity.

Features

- High-reliability package with enhanced silicone resin encapsulation
- Available in amber, red, green, and Phosphor Converted (PC) amber.
- Wide 120° viewing angle
- Small package form factor and thickness for better design flexibility
- JEDEC MSL 3

Applications

- Status indicators
- Indoor information signs and displays
- Backlight for switches
- Wearables and portable devices
- Office automations, home appliances, industrial equipment:
 - Front-panel backlighting
 - Push-button backlighting
 - Display backlighting
 - Keypad backlighting
 - Symbol backlighting

CAUTION! This LED is ESD sensitive. Observe appropriate precautions during handling and processing. Refer to application note AN-1142 for additional details.

Figure 1: Package Drawing

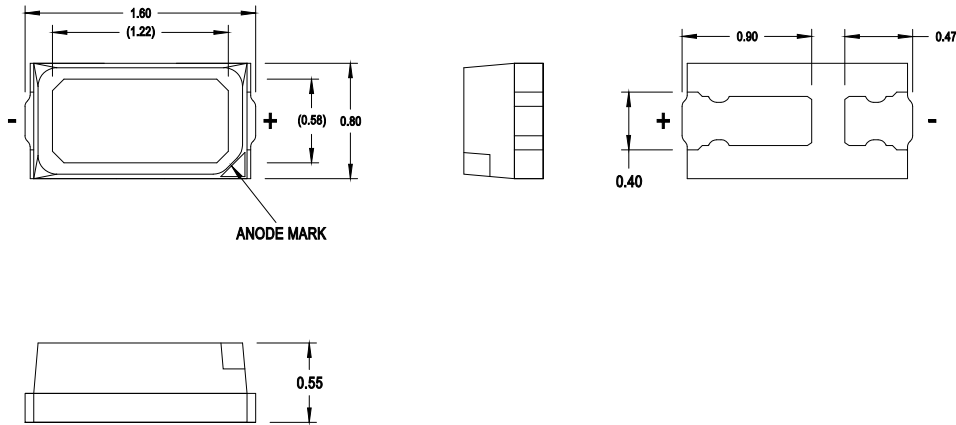

NOTE:

1. All dimensions are in millimeters (mm).
2. Tolerance is ± 0.20 mm unless otherwise specified.
3. Encapsulation = silicone.
4. Terminal finish = silver plating.
5. Dimensions in parentheses are for reference only.

Device Selection Guide ($T_J = 25^\circ\text{C}$, $I_F = 20\text{ mA}$)

Part Number	Color	Die Type	Luminous Intensity, I_V (mcd) ^{a, b}		Luminous Flux, Φ_V (lm) ^c
			Min.	Max.	Typ.
ASCKCA00-BU4V4020502	Amber	AllnGaP	525	967	2.0
ASCKCR00-BU5V5020402	Red	AllnGaP	613	1125	2.2
ASCKCG00-NW5X5020302	Green	InGaN	1540	2850	5.4
ASCKC500-NW5X4040402	PC Amber	InGaN	1540	2450	5.4

a. The luminous intensity, I_V , is measured at the mechanical axis of the package and it is tested with a single-current pulse condition. The actual peak of the spatial radiation pattern may not be aligned with the axis.

b. Luminous intensity tolerance is $\pm 12\%$.

c. For reference only.

Absolute Maximum Ratings

Parameters	AllnGaP Amber/Red	InGaN Green	InGaN PC Amber	Unit
DC Forward Current ^a	30	25	30	mA
Peak Forward Current ^b	100	100	100	mA
Power Dissipation	72	90	108	mW
Reverse Voltage	Not designed for reverse bias operation			
LED Junction Temperature	110	110	110	$^\circ\text{C}$
Operating Temperature Range	-40 to +100	-40 to +100	-40 to +100	$^\circ\text{C}$
Storage Temperature Range	-40 to +100	-40 to +100	-40 to +100	$^\circ\text{C}$

a. Derate linearly as shown in [Figure 13](#), [Figure 15](#), and [Figure 16](#).

b. Duty factor is 10%, frequency is 1 kHz, T_A is 25°C .

Optical and Electrical Characteristics ($T_J = 25^\circ\text{C}$, $I_F = 20\text{ mA}$)

Parameters	Min.	Typ.	Max.	Unit
Viewing Angle, $2\theta_{1/2}$ ^a	—	120	—	°
Forward Voltage, V_F ^b				V
Amber and Red	1.8	2.2	2.4	
Green	2.6	2.8	3.6	
PC Amber	2.6	3.0	3.6	
Reverse Current, I_R at $V_R = 5V$ ^c	—	—	10	μA
Dominant Wavelength, λ_d ^d				nm
Amber	583.0	589	595.0	
Red	615.0	622	630.0	
Green	520.0	527	530.0	
PC Amber	—	590	—	
Peak Wavelength, λ_p				nm
Amber	—	592	—	
Red	—	632	—	
Green	—	521	—	
PC Amber	—	611	—	
Thermal Resistance, $R_{\theta J-S}$ ^e				°C/W
Amber	—	90	—	
Red	—	90	—	
Green	—	220	—	
PC Amber	—	80	—	

- $\theta_{1/2}$ is the off-axis angle where the luminous intensity is half of the peak intensity.
- Forward voltage tolerance is $\pm 0.1V$.
- Indicates product final test condition. Long-term reverse bias is not recommended.
- The dominant wavelength is derived from the CIE Chromaticity diagram and represents the perceived color of the device.
- Thermal resistance from LED junction to solder point.

Part Numbering System

A S C K C x₁ 0 0 - x₂ x₃ x₄ x₅ x₆ 0 x₇ 0 x₈ 0 2

Code	Description	Option	
X ₁	Color	A	Amber
		G	Green
		R	Red
		5	PC Amber
X ₂	Die Type	B	AllnGaP
		N	InGaN
X ₃ X ₄	Minimum Intensity Bin	See Intensity Bin Limits (CAT) .	
X ₅ X ₆	Maximum Intensity Bin		
X ₇	Minimum Color Bin	See Color Bin Limits (BIN) .	
X ₈	Maximum Color Bin		

Part Number Example

ASCKCA00-BU4V4020502

X₁ : A – Amber
 X₂ : B – AllnGaP
 X₃ X₄ : U4 – Minimum intensity bin U4
 X₅ X₆ : V4 – Maximum intensity bin V4
 X₇ : 2 – Minimum color bin 2
 X₈ : 5 – Maximum color bin 5

Bin Information

Intensity Bin Limits (CAT)

Bin ID	Luminous Intensity, I_V (mcd)	
	Min.	Max.
U3	450	525
U4	525	613
U5	613	715
V3	715	832
V4	832	967
V5	967	1125
W3	1125	1320
W4	1320	1540
W5	1540	1800
X3	1800	2100
X4	2100	2450
X5	2450	2850

Tolerance = $\pm 12\%$.

Forward Voltage Bin Limits (V_F)

Bin ID	Forward Voltage, V_F (V)	
	Min.	Max.
F00	1.8	2.0
F01	2.0	2.2
F02	2.2	2.4
F03	2.4	2.6
F04	2.6	2.8
F05	2.8	3.0
F06	3.0	3.2
F07	3.2	3.4
F08	3.4	3.6

Tolerance = $\pm 0.1V$.

Color Bin Limits (BIN)

Amber

Bin ID	Dominant Wavelength, λ_d (nm)	
	Min.	Max.
2	583.0	586.0
3	586.0	589.0
4	589.0	592.0
5	592.0	595.0

Red

Bin ID	Dominant Wavelength, λ_d (nm)	
	Min.	Max.
2	615.0	620.0
3	620.0	625.0
4	625.0	630.0

Green

Bin ID	Dominant Wavelength, λ_d (nm)	
	Min.	Max.
2	520.0	525.0
3	525.0	530.0

Tolerance = ± 1 nm.

PC Amber

Bin ID	Chromaticity Coordinates	
	x	y
4	0.5504	0.4224
	0.5693	0.4301
	0.5867	0.4128
	0.5664	0.4064

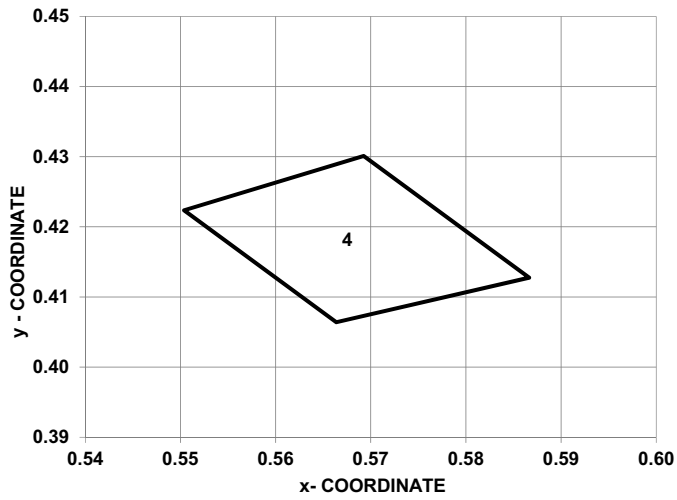
Figure 2: Chromaticity Diagram

NOTE: The corresponding dominant wavelength is from 589 nm to 592 nm.

Example of bin information on reel and packaging label:

CAT: U4 – Intensity bin U4
BIN: 2 – Color bin 2
VF: F01 – VF bin F01

Figure 3: Spectral Power Distribution

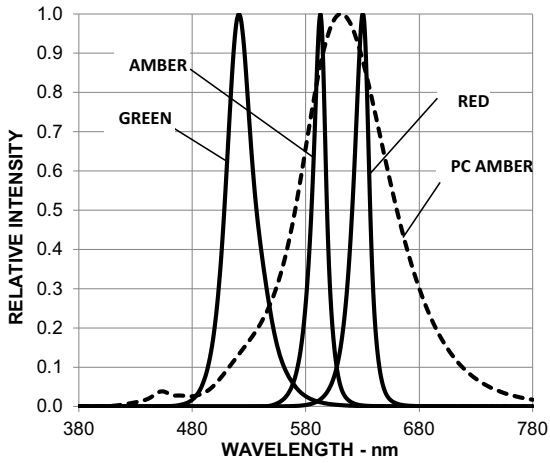

Figure 4: Forward Current vs. Forward Voltage

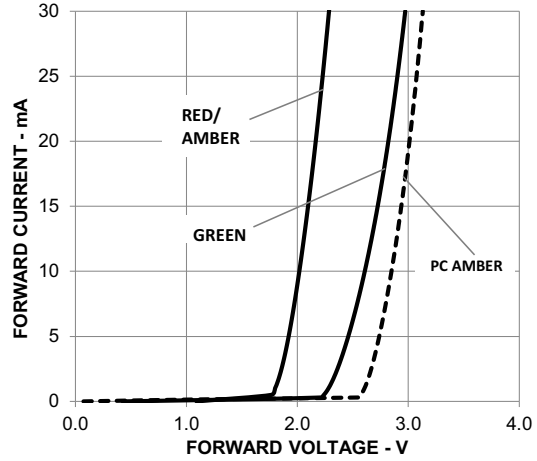

Figure 5: Relative Luminous Intensity vs. Mono Pulse Current

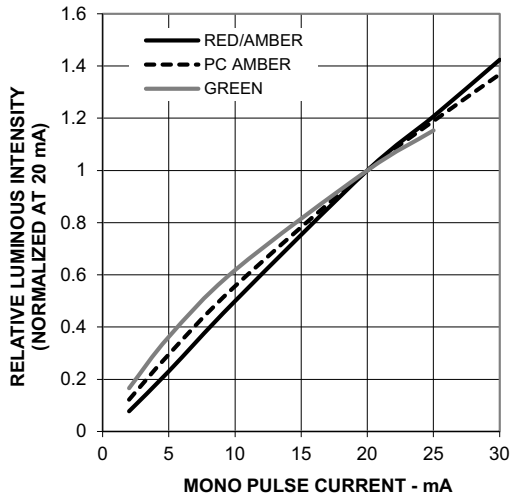

Figure 6: Radiation Pattern

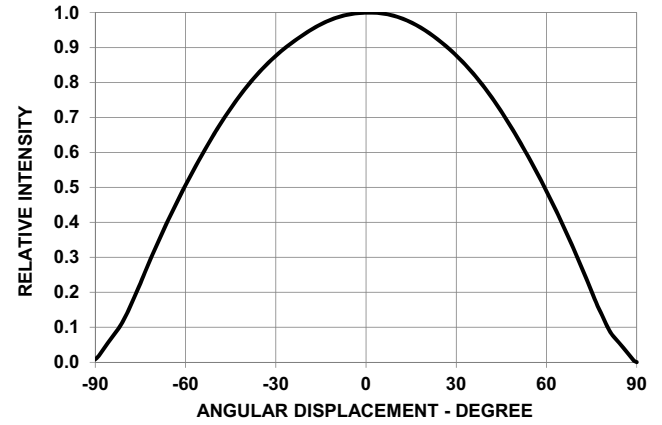

Figure 7: Dominant Wavelength Shift vs. Mono Pulse Current (Red, Amber, Green)

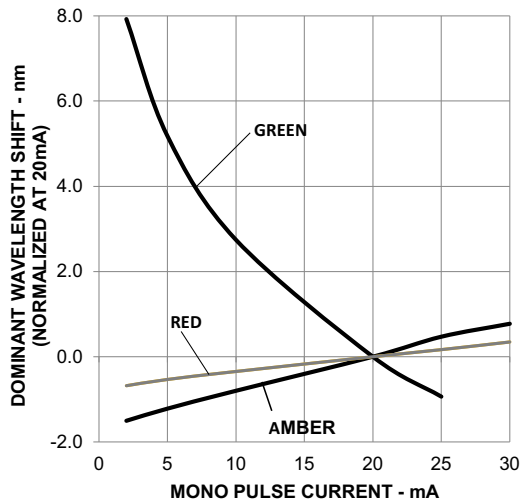

Figure 8: Chromaticity Coordinate Shift vs. Mono Pulse Current (PC Amber)

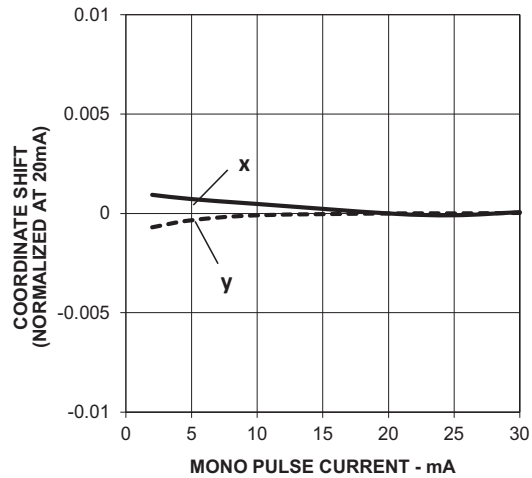

Figure 9: Forward Voltage Shift vs. Junction Temperature

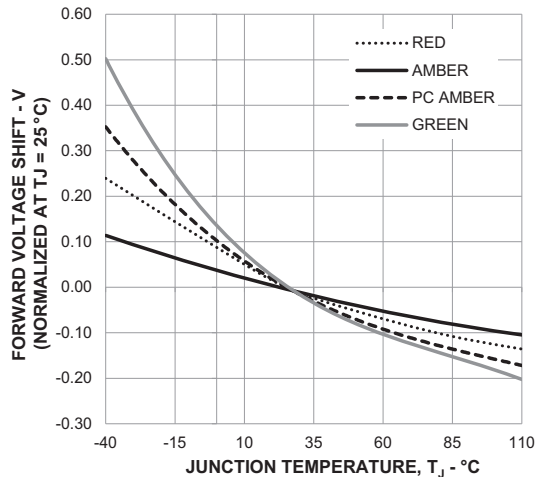

Figure 10: Relative Luminous Intensity vs. Junction Temperature

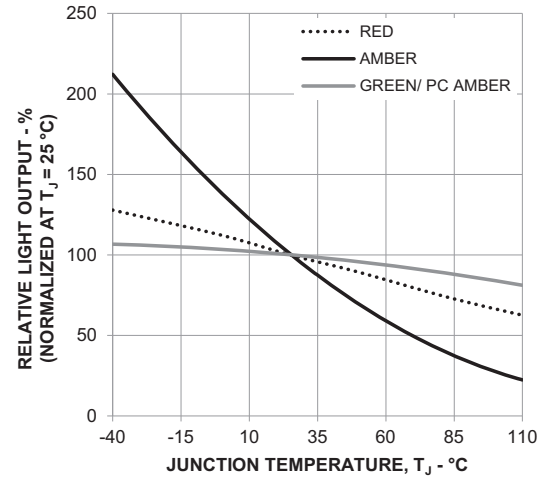

Figure 11: Dominant Wavelength Shift vs. Junction Temperature

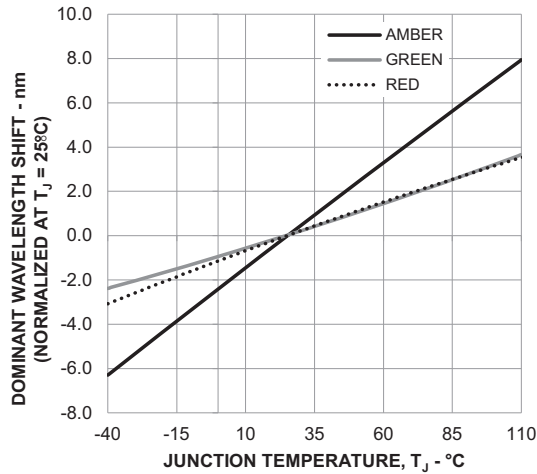

Figure 12: Chromaticity Coordinate Shift vs. Junction Temperature (PC Amber)

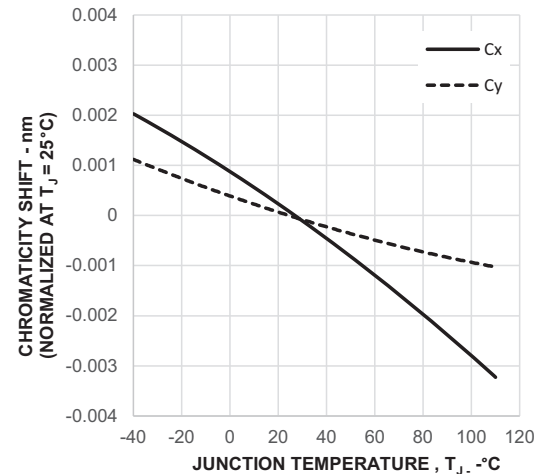

Figure 13: Maximum Forward Current vs. Ambient Temperature. Derated Based on $T_{JMAX} = 110^{\circ}C$ (Red, Amber)

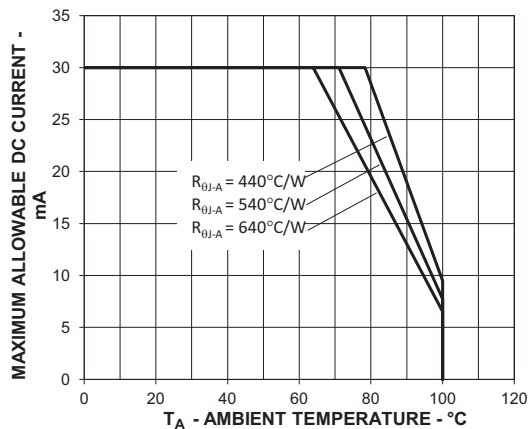

Figure 14: Maximum Forward Current vs. Solder Point Temperature. Derated Based on $T_{JMAX} = 110^{\circ}C$ (Red, Amber, PC Amber)

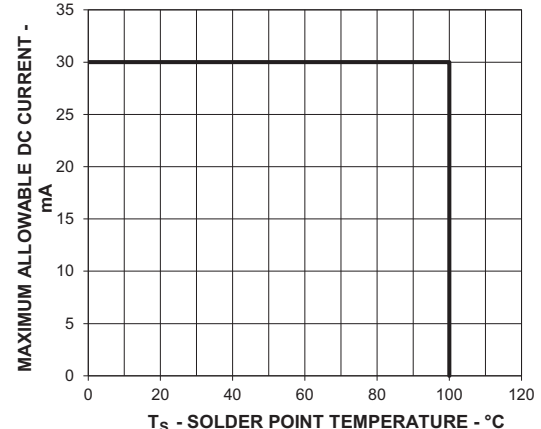

Figure 15: Maximum Forward Current vs. Ambient Temperature. Derated Based on $T_{JMAX} = 110^{\circ}C$ (Green)

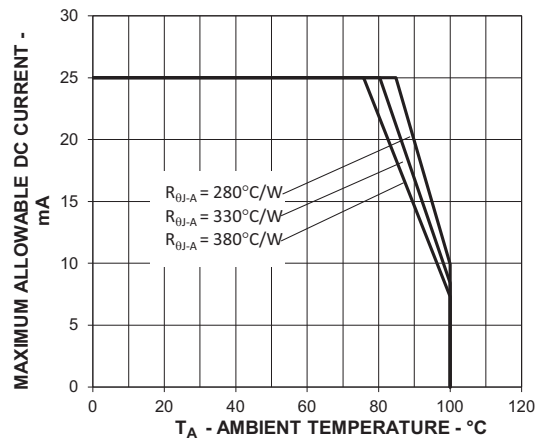

Figure 16: Maximum Forward Current vs. Ambient Temperature. Derated Based on $T_{JMAX} = 110^{\circ}C$ (PC Amber)

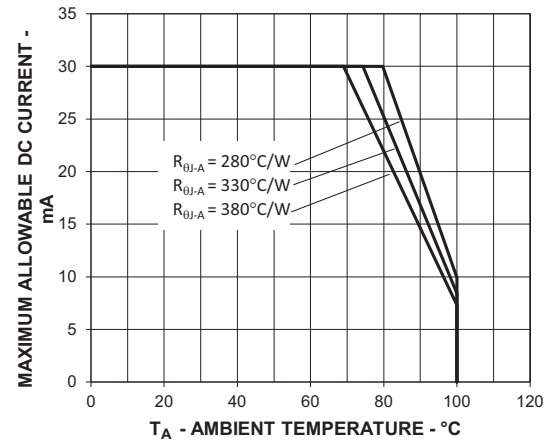

Figure 17: Maximum Forward Current vs. Solder Point Temperature. Derated Based on $T_{JMAX} = 110^{\circ}C$ (Green)

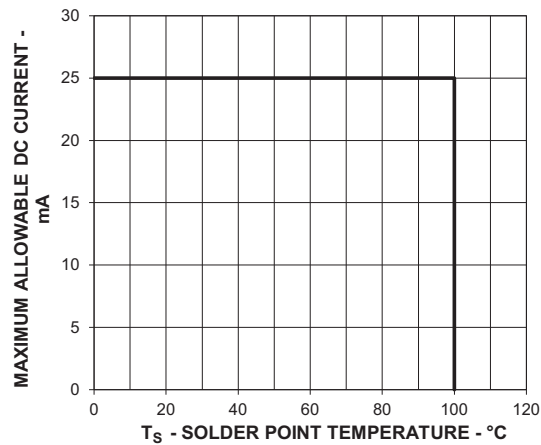
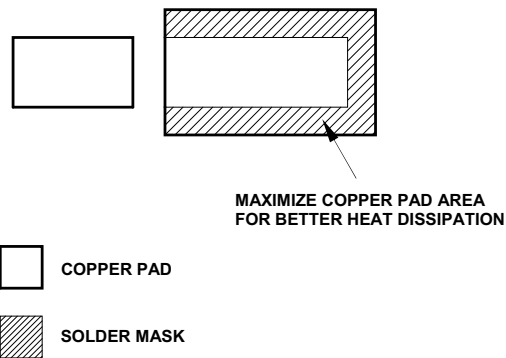
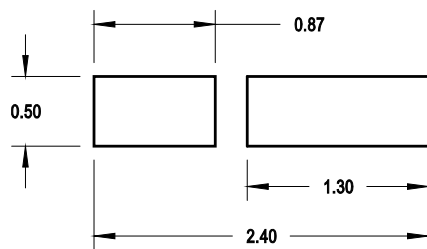
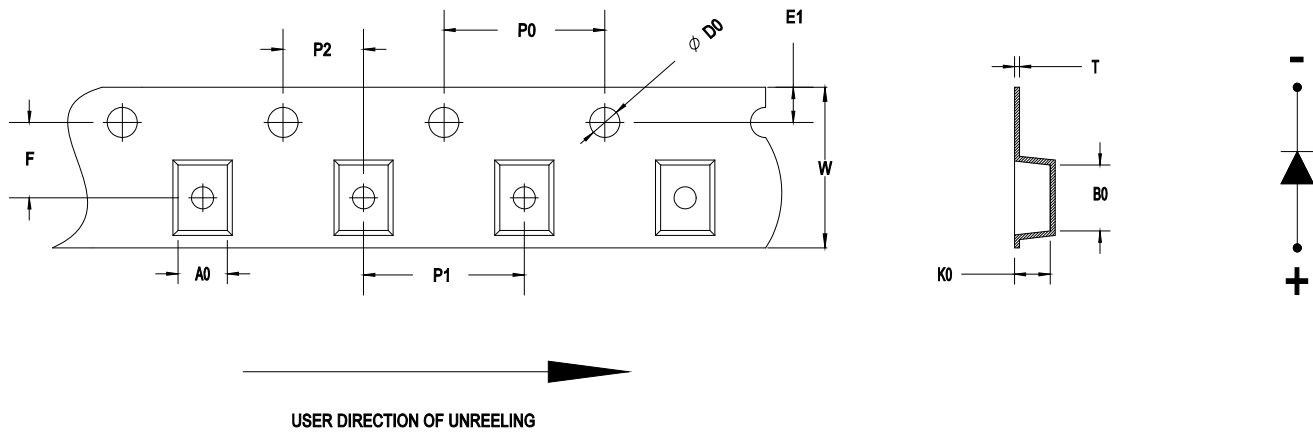

Figure 18: Recommended Soldering Land Pattern



NOTE: All dimensions are in millimeters (mm).

Figure 19: Carrier Tape Dimensions



F	P0	P1	P2	D0	E1	W
3.50 ± 0.05	4.00 ± 0.10	4.00 ± 0.10	2.00 ± 0.05	1.55 + 0.05	1.75 ± 0.10	8.00 ± 0.30
T	B0	K0	A0			
0.20 ± 0.05	1.75 ± 0.10	0.68 ± 0.10	0.90 ± 0.10			

NOTE:

1. All dimensions are in millimeters (mm).
2. Quantity per reel: 4000 pieces.

Figure 20: Reel Dimensions

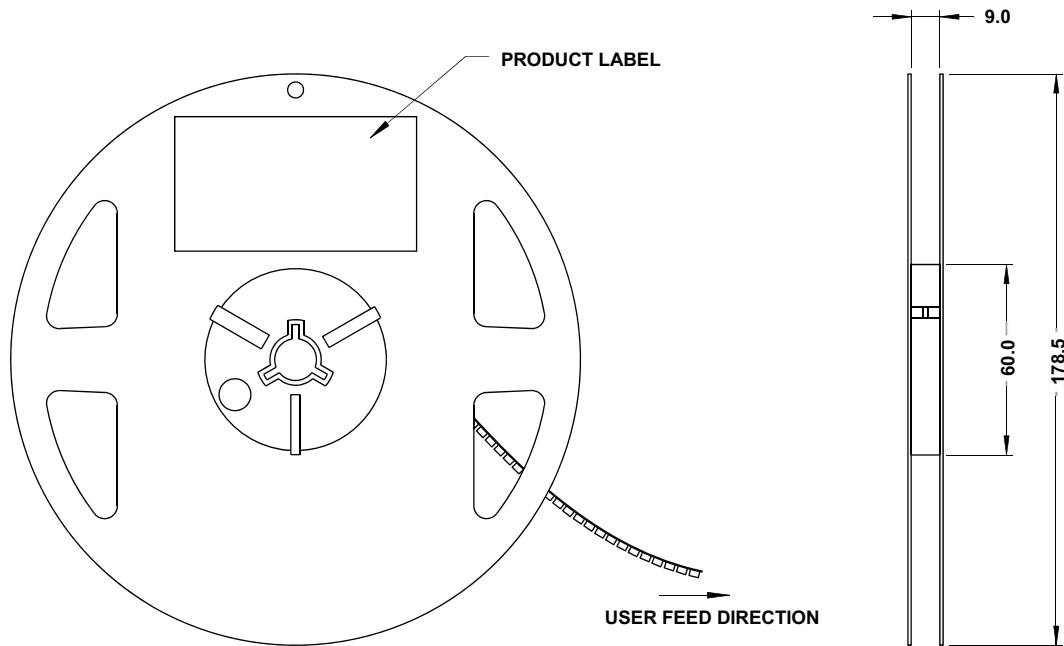

NOTE: All dimensions are in millimeters (mm).

Precautionary Notes

Soldering

- Do not perform reflow soldering more than twice. Observe necessary precautions of handling moisture-sensitive devices as stated in the following section.
- Do not apply any pressure or force on the LED during reflow and after reflow when the LED is still hot.
- Use reflow soldering to solder the LED. Use hand soldering only for rework if unavoidable, but it must be strictly controlled to following conditions:
 - Soldering iron tip temperature = 315°C maximum
 - Soldering duration = 3 seconds maximum
 - Number of cycles = 1 only
 - Power of soldering iron = 50W maximum
- Do not touch the LED package body with the soldering iron except for the soldering terminals because it may cause damage to the LED.
- Confirm beforehand whether the functionality and performance of the LED are affected by soldering with hand soldering.

Figure 21: Recommended Lead-Free Reflow Soldering Profile

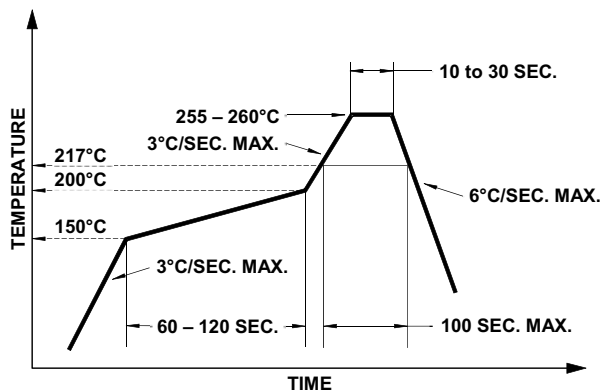

Handling Precautions

The encapsulation material of the LED is made of silicone for better product reliability. Compared to epoxy encapsulant, which is hard and brittle, silicone is softer and flexible. Observe special handling precautions during assembly of silicone encapsulated LED products. Failure to comply might lead to damage and premature failure of the LED. For additional information, refer to Broadcom Application Note 5288, *Silicone Encapsulation for LED: Advantages and Handling Precautions*.

- Do not poke sharp objects into the silicone encapsulant. Sharp objects, such as tweezers or syringes, might apply excessive force or even pierce through the silicone and induce failures to the LED die or wire bond.
- Do not touch the silicone encapsulant. Uncontrolled force acting on the silicone encapsulant might result in excessive stress on the wire bond. Hold the LED by the body only.
- Do not stack assembled PCBs together. Use an appropriate rack to hold the PCBs.
- The surface of silicone material attracts dust and dirt easier than epoxy, due to its surface tackiness. To remove foreign particles on the surface of silicone, use a cotton bud with isopropyl alcohol (IPA). During cleaning, rub the surface gently without putting too much pressure on the silicone. Ultrasonic cleaning is not recommended.

Handling Moisture-Sensitive Devices

This product has a Moisture Sensitive Level 3 rating per JEDEC J-STD-020. For additional details and a review of proper handling procedures, refer to Broadcom Application Note 5305, *Handling of Moisture Sensitive Surface-Mount LEDs*.

- Before use:
 - An unopened moisture barrier bag (MBB) can be stored at $40^{\circ}\text{C}/90\% \text{RH}$ for 12 months. If the actual shelf life has exceeded 12 months and the Humidity Indicator Card (HIC) indicates that baking is not required, then it is safe to reflow the LEDs per the original MSL rating.
 - Do not open the MBB prior to assembly (for example, for IQC). If unavoidable, the MBB must be properly resealed with fresh desiccant and HIC. The exposed duration must be taken in as floor life.
- Control after opening the MBB:
 - Read the HIC immediately upon opening the MBB.
 - Keep the LEDs at $30^{\circ}/60\% \text{RH}$ at all times, and complete all high temperature-related processes, including soldering, curing, or rework within 168 hours.
- Control for unfinished reel:

Store unused LEDs in a sealed MBB with desiccant or a desiccator at $5\% \text{RH}$.
- Control of assembled boards:

If the PCB soldered with the LEDs is to be subjected to other high-temperature processes, store the PCB in a sealed MBB with desiccant or desiccator at $5\% \text{RH}$ to ensure that all LEDs have not exceeded their floor life of 168 hours.
- Baking is required if any of these conditions exist:
 - The HIC indicates a change in color for 10% and 5%, as stated on the HIC.
 - The LEDs are exposed to conditions of $30^{\circ}\text{C}/60\% \text{RH}$ at any time.
 - The LED's floor life exceeded 168 hours.

The recommended baking condition is $60^{\circ}\text{C} \pm 5^{\circ}\text{C}$ for 20 hours.

Baking can only be done once.
- Storage:

The soldering terminals of these Broadcom LEDs are silver plated. If the LEDs are exposed in an ambient environment for too long, the silver plating might be oxidized, thus affecting its solderability performance. As such, keep unused LEDs in a sealed MBB with desiccant or in a desiccator at $5\% \text{RH}$.

Application Precautions

- The drive current of the LED must not exceed the maximum allowable limit across temperature as stated in this data sheet. Constant current driving is recommended to ensure consistent performance.
- Circuit design must cater to the whole range of forward voltage (V_F) of the LEDs to ensure the intended drive current can always be achieved.
- The LED exhibits slightly different characteristics at different drive currents, which may result in a larger variation of performance (such as intensity, wavelength, and forward voltage). Set the application current as close as possible to the test current to minimize these variations.
- The LED is not intended for reverse bias. Use other appropriate components for such purposes.
- Do not use the LED in the vicinity of material with sulfur content or in environments of high gaseous sulfur compounds and corrosive elements. Examples of material that might contain sulfur are rubber gaskets, room-temperature vulcanizing (RTV) silicone rubber, rubber gloves, and so on. Prolonged exposure to such environments may affect the optical characteristics and product life of the LED.
- White LEDs must not be exposed to acidic environments and must not be used in the vicinity of any compound that may have acidic outgas, such as, but not limited to, acrylate adhesive. These environments have an adverse effect on LED performance.
- Avoid rapid change in ambient temperature, especially in high-humidity environments, because they cause condensation on the LED.
- If the LED is intended to be used in a harsh or outdoor environment, protect the LED against damages caused by rainwater, water, dust, oil, corrosive gases, external mechanical stresses, and so on.

Thermal Management

The optical, electrical, and reliability characteristics of the LED are affected by temperature. Keep the junction temperature (T_J) of the LED below the allowable limit at all times. T_J can be calculated as follows:

$$T_J = T_A + R_{\theta J-A} \times I_F \times V_{Fmax}$$

where:

T_A = Ambient temperature ($^{\circ}\text{C}$)

$R_{\theta J-A}$ = Thermal resistance from LED junction to ambient ($^{\circ}\text{C}/\text{W}$)

I_F = Forward current (A)

V_{Fmax} = Maximum forward voltage (V)

The complication of using this formula lies in T_A and $R_{\theta J-A}$. Actual T_A is sometimes subjective and hard to determine. $R_{\theta J-A}$ varies from system to system depending on design and is usually not known.

Another way of calculating T_J is by using the solder point temperature, T_S as follows:

$$T_J = T_S + R_{\theta J-S} \times I_F \times V_{Fmax}$$

where:

T_S = LED solder point temperature as shown in the following figure ($^{\circ}\text{C}$)

$R_{\theta J-S}$ = Thermal resistance from junction to solder point ($^{\circ}\text{C}/\text{W}$)

I_F = Forward current (A)

V_{Fmax} = Maximum forward voltage (V)

Figure 22: Solder Point Temperature on PCB

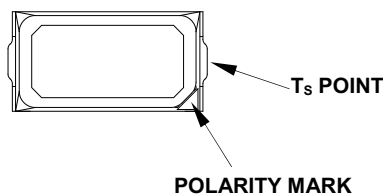

T_S can be easily measured by mounting a thermocouple on the soldering joint as shown in preceding figure, while $R_{\theta J-S}$ is provided in this data sheet. Verify the T_S of the LED in the final product to ensure that the LEDs are operating within all maximum ratings stated in this data sheet.

Eye Safety Precautions

LEDs may pose optical hazards when in operation. Do not look directly at operating LEDs because it might be harmful to the eyes. For safety reasons, use appropriate shielding or personal protective equipment.

Disclaimer

Broadcom's products and software are not specifically designed, manufactured, or authorized for sale as parts, components, or assemblies for the planning, construction, maintenance, or direct operation of a nuclear facility or for use in medical devices or applications. The customer is solely responsible, and waives all rights to make claims against Broadcom or its suppliers, for all loss, damage, expense, or liability in connection with such use.

Copyright © 2023-2024 Broadcom. All Rights Reserved. The term "Broadcom" refers to Broadcom Inc. and/or its subsidiaries. For more information, go to www.broadcom.com. All trademarks, trade names, service marks, and logos referenced herein belong to their respective companies.

Broadcom reserves the right to make changes without further notice to any products or data herein to improve reliability, function, or design. Information furnished by Broadcom is believed to be accurate and reliable. However, Broadcom does not assume any liability arising out of the application or use of this information, nor the application or use of any product or circuit described herein, neither does it convey any license under its patent rights nor the rights of others.

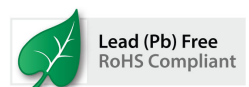

Mouser Electronics

Authorized Distributor

Click to View Pricing, Inventory, Delivery & Lifecycle Information:

[Broadcom Limited:](#)

[ASCKC500-NW5X4040402](#) [ASCKCA00-BU4V4020502](#) [ASCKCB00-NS3T4010302](#) [ASCKCF00-AP5R5010402](#)
[ASCKCG00-NW5X5020302](#) [ASCKCR00-BU5V5020402](#)