

AEAT-9988M

Magnetic Encoder IC: High-Resolution 23-Bit Absolute Incremental Encoder



Description

The Broadcom[®] AEAT-9988M is an angular magnetic rotary sensor that provides accurate angular measurement over a full 360 degrees of rotation. It is a versatile solution capable of supporting a broad range of applications with its robust architecture to measure and deliver both absolute and incremental signals.

This sophisticated system uses integrated Hall sensor elements with complex analog and digital signal processing within a single device.

A dual-track magnet generates the necessary magnetic fields by rotating perpendicularly. A wide range of selection is available on the magnet ring sizes, from 20-mm to 50-mm inner diameter.

The absolute angle measurement provides an instant indication of the magnet's angular position with a selectable and reprogrammable resolution from 16 bits to 23 bits. When selected, its absolute positioning data is then represented in its digital form to be assessed through a standard SSI, SPI, BiSS-C, or RS-485 communication protocol.

The AEAT-9988M also has a built-in multi-turn counter with battery backup power-off mode operation. The multi-turn resolution is programmable from 10 bits to 16 bits.

Users can choose to receive the absolute angle position in PWM-encoded output signals. Incremental positions are transmitted on ABI and UVW signals with wide user-configurable resolutions from 1 CPR to 65,536 CPR of ABI signals and pole pairs from 1 to 64 pole pairs (2 to 128 poles) for UVW commutation signals.

Features

- 5V operating voltage
- Operating temperature from -40°C to 125°C
- 500- μA current consumption in Sleep Mode
- Programmable 16 bits up to 23 bits of absolute resolution
- Programmable 10 bits up to 16 bits counter operation
- Programmable Incremental ABI resolution ranging from 1 CPR to 65,536 CPR
- Commutation angle output UVW 1 pp to 32 pp
- Dedicated output pin for ABI, UVW, and serial interface
- Dedicated zero reset and error pin
- EEPROM architecture for multi-time user configuration
- Optional 56-bit memory lock function
- Selectable communication protocols
- RS-485 (2.5/5/10 Mb/s)
- SSI 3-wire (up to 10 MHz)
- SPI 4-wire (up to 20 MHz)
- BiSS-C (up to 10 MHz)
- Programmable function to external hardware pin (GPIO)
- Compact DFN-30 leads (8.2 mm \times 5 mm) package

Applications

- Brushless DC motor and stepper motor
- Resolver and potentiometer replacement
- Industrial automation and robotics
- Industrial sewing machine and textiles equipment
- Light Detection and Range (LiDAR)

NOTE: This product is not specifically designed or manufactured for use in any specific device. Customers are solely responsible for determining the suitability of this product for its intended application and solely liable for all loss, damage, expense, or liability in connection with such use.

Functional Description

Figure 1: AEAT-9988M Block Diagram

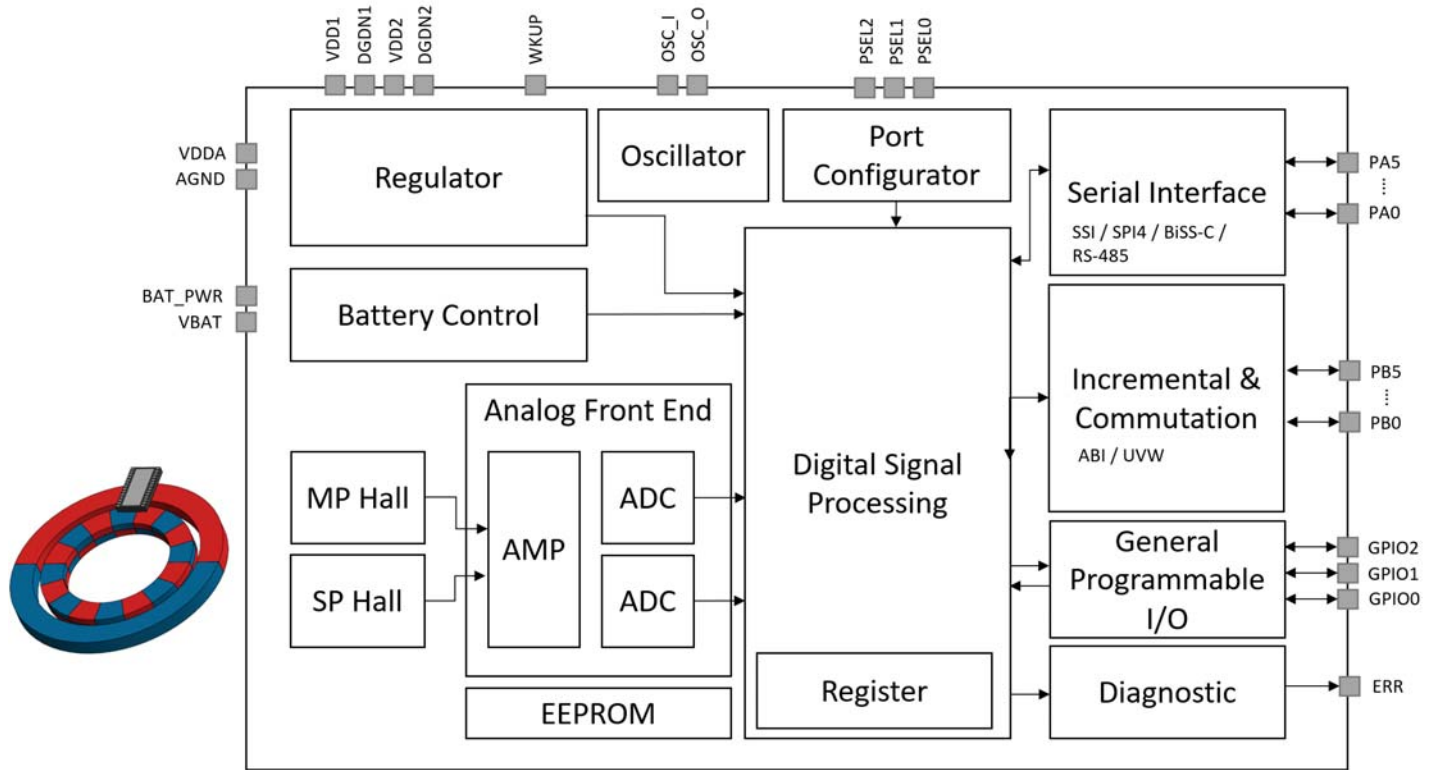

The AEAT-9988M is manufactured with a CMOS standard process. It is capable of accurately measuring a magnet's rotational angle when it is placed in alignment and in perpendicular to the device by using its integrated Hall sensors to detect its magnetic field. The detected magnetic signals are then taken as input signals to be properly conditioned to negate its non-idealities before inputting them into the analog amplifiers for strength amplification and filtering. The amplified analog signals are then fed into the internal analog-to-digital converter (ADC) to be converted into digital signals for the final stage of digital processing. The digital processing provides a digitized output of the absolute and incremental signals.

The magnet used should have sufficient magnetic field strength (mT) to generate the magnetic field for the signal generation as highlighted in [Recommended Magnetic Input Specifications](#). The device provides digital information of magnetic field strength high (MHi) and magnetic field strength low (MLo) from output protocols to indicate whether the magnets are too close or too far away from the device's surface.

Users can assess the device's digitized absolute data using standard Synchronous Serial Interface (SSI), Serial Peripheral Interface (SPI), BiSS-C, or RS-485 protocols. In addition, an absolute angular representation also can be selected using a pulse-width modulated (PWM) signal.

The incremental outputs are available from the digital outputs of their dedicated A, B, and I pins and the commutation output U, V and W.

Pin Assignment

Figure 2: Pin Configuration

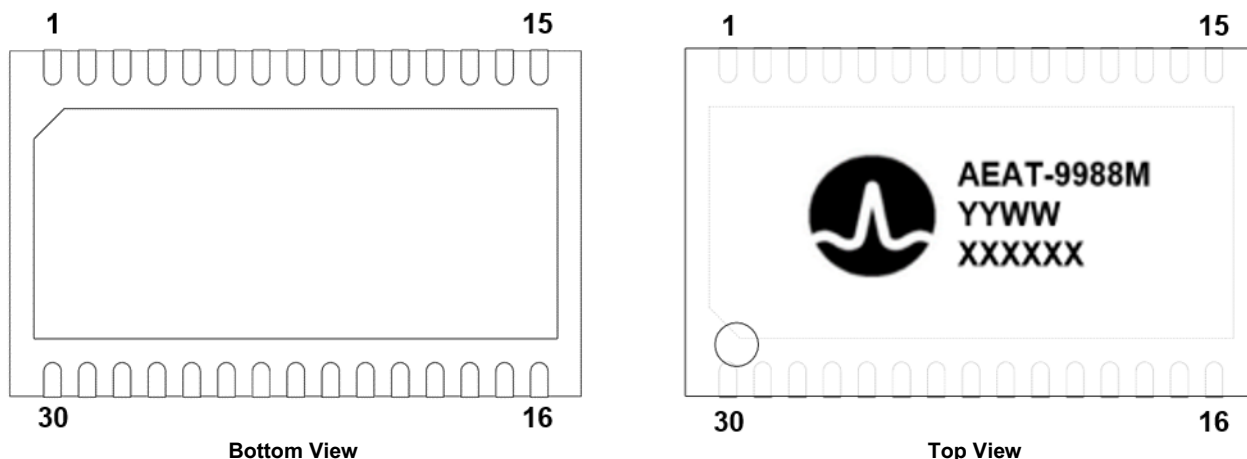

Pinout Description

Pin QFN32	Pin Name	Pin Type	Description	Pin QFN32	Pin Name	Pin Type	Description
1	PSEL0	I	Port Configurator	16	PB5	O	Port B Communication
2	PSEL1	I	Port Configurator	17	PB4	O	Port B Communication
3	PSEL2	I	Port Configurator	18	PB3	O	Port B Communication
4	VDDA	S	Analog Supply	19	PB2	O	Port B Communication
5	AGND	S	Analog Ground	20	PB1	O	Port B Communication
6	PA0	I/O	Port A Communication	21	PB0	O	Port B Communication
7	PA1	I/O	Port A Communication	22	DGND2	S	Digital Ground
8	VDD1	S	Digital Supply	23	VDD2	S	Digital Supply
9	DGND1	S	Digital Ground	24	GPIO2	I/O	Programmable I/O
10	PA2	I/O	Port A Communication	25	GPIO1	I/O	Programmable I/O
11	PA3	I/O	Port A Communication	26	GPIO0	I/O	Programmable I/O
12	PA4	O	Port A Communication	27	VBAT	S	Battery Supply
13	PA5	O	Port A Communication	28	BAT_PWR	I	Battery Detection
14	OSC_I	I	Sync Clock Input	29	ERR	O	Error Output
15	OSC_O	O	Sync Clock Output	30	WKUP	I	Wake-Up Control

Absolute Maximum Ratings

Parameter	Symbol	Min.	Max.	Unit
Storage Temperature	T_S	-40	125	°C
DC Supply Voltage VDDA Pin	VDDA	-0.3	6.0	V
Input Voltage Range	V_{in}	-0.3	6	V
Electrostatic Discharge (HBM)	—	-2.0	+2.0	kV
Moisture Sensitivity Level	—	—	1	—

CAUTION! Subjecting the product to stresses beyond those listed in this section may cause permanent damage to the devices. These are stress ratings only and do not imply that the devices will function beyond these ratings. Exposure to the extremes of these conditions for extended periods may affect product reliability.

Electrical Characteristics

Recommended Operating Conditions

Parameter	Symbol	Min.	Typ.	Max.	Unit	Notes
Operating Ambient Temperature	T_A	-40	—	125	°C	
DC Supply Voltage						
To VDDA Pin	VDDA	4.5	5.0	5.5	V	
To VDD Pin: 5V Operation	VDD	4.5	5.0	5.5	V	
To VDD Pin: 3.3V Operation	VDD	3.0	3.3	3.6	V	VDD 3.3V operation only recommended for SPI4 single-ended
Incremental Output Frequency	f_{MAX}	—	—	5.0	MHz	Frequency = Velocity (rpm) × CPR/60
Load Capacitance	CL	—	—	15	pF	

Systems Parameters

Condition: Electrical characteristics over the recommended operating conditions. Typical values specified at VDD = 5.0V and 25°C, with optimum placement of magnet.

Parameter	Symbol	Min.	Typ.	Max.	Unit	Notes
Current Consumption						
Supply Current Normal Operation Mode	$I_{DA_{NOM}}$	—	52	—	mA	
	$I_{DD_{NOM}}$	—	100	—	μA	No load
Supply Current Sleep Mode	$I_{DA_{IDLE}}$	—	500	—	μA	
	$I_{DD_{IDLE}}$	—	100	—	μA	
Digital Outputs (DO)						
High Level Output Voltage	V_{OH}	VDD - 0.5	—	—	V	Normal operation
Low Level Output Voltage	V_{OL}	—	—	GND + 0.4	V	

Parameter	Symbol	Min.	Typ.	Max.	Unit	Notes
Power-Up Time Absolute Output Incremental Output PWM Output	t_{PwrUp}	—	10	—	ms	
Digital Inputs (DI)						
Input High Level	V_{IH}	$0.7 \times V_{DD}$	—	—	V	
Input Low Level	V_{IL}	—	—	$0.3 \times V_{DD}$	V	
Pull-Up Low Level Input Current	I_{IL}	—	—	120	μA	
Pull-Down High Level Input Current	I_{IH}	—	—	120	μA	

Encoding Characteristics

Parameter	Symbol	Min.	Typ.	Max.	Unit	Notes
Absolute Output						
Resolution	RES	16	—	23	Bit	Programmable 16 bits to 23 bits.
Integral Non-Linearity	INL_{nom}	—	± 0.02	—	Deg	Best fit line, centered magnet. $T_A = 25^\circ C$, INL angle correction.
Integral Non-Linearity	INL_{dis}	—	± 0.25	—	Deg	Best fit line, over displacement of magnet. $T_A = 25^\circ C$.
Integral Non-Linearity	INL_{temp}	—	± 0.20	—	Deg	Best fit line, over temperature range. $T_A = -40^\circ C$ to $+125^\circ C$.
Differential Non-Linearity	DNL_{nom}	—	± 0.002	—	Deg	$T_A = 25^\circ C$.
Output Sampling Rate	f_S	—	10	—	MHz	Based on SSI protocol.
Latency	—	—	80	—	ns	At constant speed.
Multi-turn Output						
Resolution	RES	0	—	16	Bit	Programmable OFF, and 10 bits to 16 bits.
Incremental Output (Channel ABI)						
Resolution	R_{INC}	1	—	65,536	CPR	Programmable.
Index Pulse Width	P_O	90	—	360	$^\circ e$	Programmable options: $90^\circ e$, $180^\circ e$, $270^\circ e$, or $360^\circ e$. Refer to Application Note.
Index Pulse State	P_S	90	—	360	$^\circ e$	Relation between index output to incremental AB state. Programmable options: $0^\circ e$, $90^\circ e$, $180^\circ e$, or $270^\circ e$. Refer to <i>AEAT-9988M Application Note</i> .
Index State	—	90	—	360	$^\circ e$	Programmable options: $90^\circ e$, $180^\circ e$, $270^\circ e$, or $360^\circ e$. Refer to <i>AEAT-9988M Application Note</i> .
PWM Output						
PWM Frequency	f_{PWM}	122	—	976	Hz	Adjustable based on the PWM settings.
Minimum Pulse Width	PW_{MIN}	—	1	—	μs	
Maximum Pulse Width	PW_{MAX}	—	16,384	—	μs	

NOTE: Encoding characteristics over recommended operating range, unless otherwise specified.

Recommended Magnetic Input Specifications

Parameter	Symbol	Min.	Typ.	Max.	Unit	Notes	
Diameter OD	Single-Pole Magnet	$MP_{OD} + 3$	—	60	mm	Configuration: The single-pole ring magnet is placed on the outer track, and the multi-pole ring magnet is placed on the inner track. The air gap between both magnets is 1.5 mm.	
	Multi-Pole Magnet						MP_{OD}
Magnet Width	Single-Pole Magnet	—	4.0	—	mm		
	Multi-Pole Magnet	—	3.0	—	mm		
Thickness	t	—	3.0	—	mm		
Magnetic Input Filed Magnitude	Single-Pole Magnet	30	—	150	mT		
	Multi-Pole Magnet	40	—	100	mT		
Magnet Displacement Radius	R_m	—	—	0.25	mm		Displacement between the magnet axis and the device center
Recommended Magnet Material and Temperature Drift	—	—	-0.12	—	%/K		NdFeB (Neodymium Iron Boron), grade N35SH.

Magnet Magnetization

Figure 3: Single-Pole: Diametrical Magnetization



Figure 4: Multi-pole: Axial Magnetization

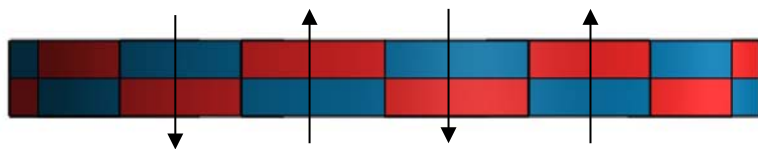

Magnet and IC Package Placement

The AEAT-9988M multi-axis capability comes from multiple integrated Hall devices that allow flexibility on the sensor mounting with respect to the magnet. Generally, the shaft-end configuration senses the vertical field (the Z component is perpendicular to chip surface) and the rest of the configuration senses the horizontal field (the X and Y components are parallel to the chip surface).

Refer to the *AEAT-9988M Application Note* for details regarding the magnet design and IC placement.

Figure 5: Magnet Design and IC Placement

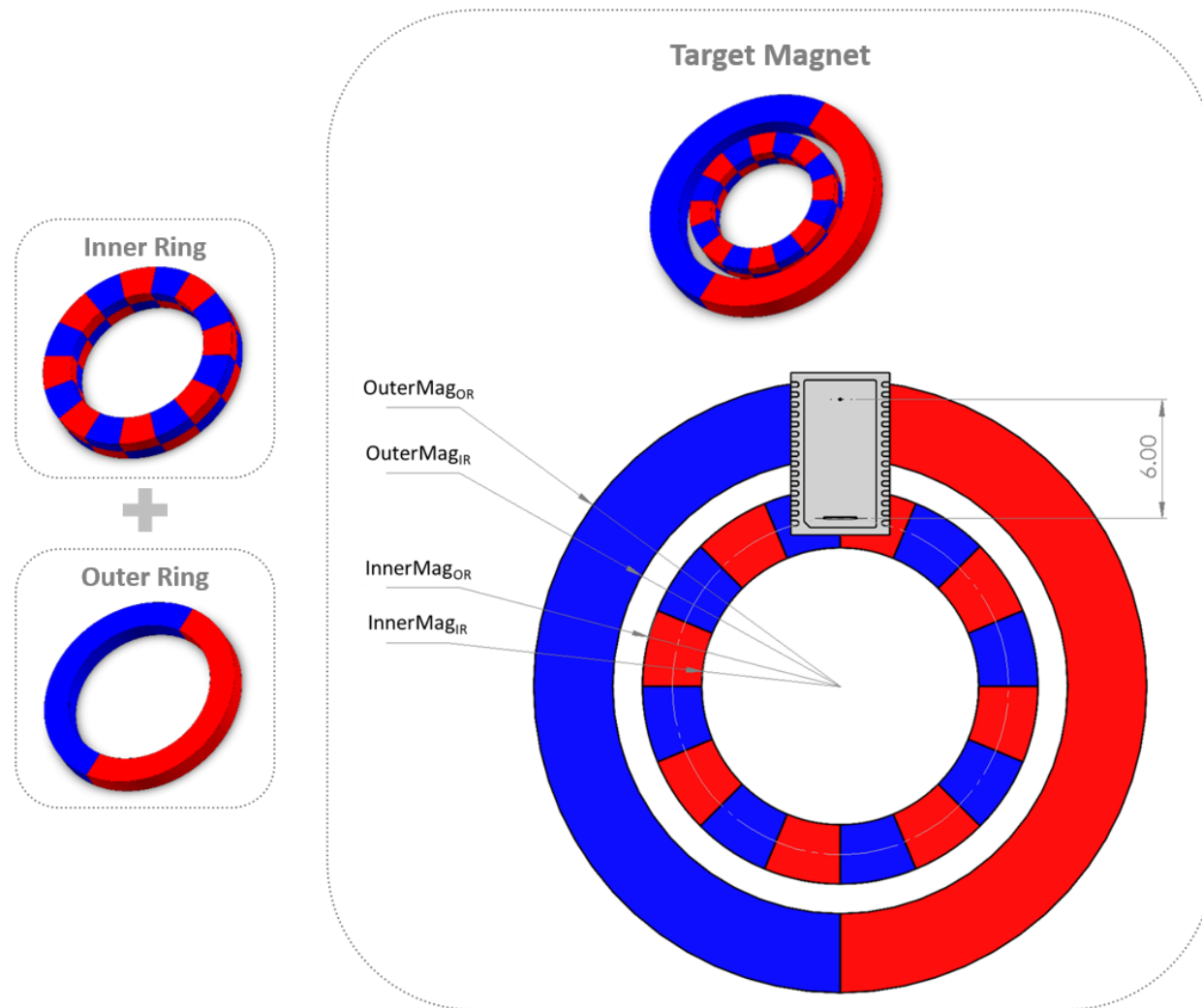

NOTE:

- OuterMag_{OR}: Outer radius of outer ring magnet.
- OuterMag_{IR}: Inner radius of outer ring magnet.
- InnerMag_{OR}: Outer radius of inner ring magnet.
- InnerMag_{IR}: Inner radius of inner ring magnet.

Communication Protocol: Serial Interface Format

The AEAT-9988M serial interface hosts up to 10 different communication interfaces for position output and memory access. The protocol is configurable with the PSEL pin (2 to 0). The output pin can be configured to high impedance mode for multi-client connection or bus connection.

The AEAT-9988M has two communications ports, Port A and Port B:

- Port A communication supports both Single Ended (SE) and Differential with Line Driver (LD) modes, ensuring compatibility across various systems. This versatility extends to its SPI capabilities accommodating SPI3 and SPI4 (16-bit parity and 8-bit Operation Command [OC]) functionalities. Additionally, it facilitates SSI via SSI3 and SSI2. Beyond these standard interfaces, Port-Com in Port A configuration integrates seamlessly with other protocols including BiSS-C, RS-485, PWM, and UVW.
- Port B configuration is for incremental configuration. When operating in Single Ended mode, it is able to support simultaneous ABI and UVW output. Transitioning to Differential with Line Driver mode, Port B ensures ABI output in a differential format.

All protocol selection can be switched during operation.

Table 1: MATS Table

Port Configurator									
PSEL2	0	0	0	0	0	1	1	1	1
PSEL1	0	0	0	1	1	0	0	1	1
PSEL0	0	0	1	0	1	0	1	0	1
Port Assignment									
	SPI3	SSI	SSI	BiSS-C	BiSS-C	RS-485	RS-485	SPI4	UVW/PWM
	SE	SE	LD	SE	LD	SE	LD	SE	LD
PA0	MOSI	NSL	NSL+	SLI	SLI+	RX		MOSI	U+
PA1	0	1	NSL-		SLI-			NCS	U-
PA2	SCK	SCK	SCL+	MA	MA+	TX	D+	SCK	V+
PA3			SCL-		MA-		D-		V-
PA4	MISO	SOUT	SLO+	SLO	SLO+	CTS		MISO	W+
PA5	PWM	PWM	SLO-		SLO-	PWM		PWM	W-
PB0	A	A	A+	A	A+	A	A+	A	A+
PB1	U	U	A-	U	A-	U	A-	U	A-
PB2	B	B	B+	B	B+	B	B+	B	B+
PB3	V	V	B-	V	B-	V	B-	V	B-
PB4	I	I	I+	I	I+	I	I+	I	I+
PB5	W	W	I-	W	I-	W	I-	W	I-

NOTE:

- To activate the SPI3 SE protocol, assert 0 on the PA1.
- To activate SSI SE protocol, assert 1 on the PA1.

Package Drawings (in mm)

Figure 6: AEAT-9988M, 30 DFN Dimensions

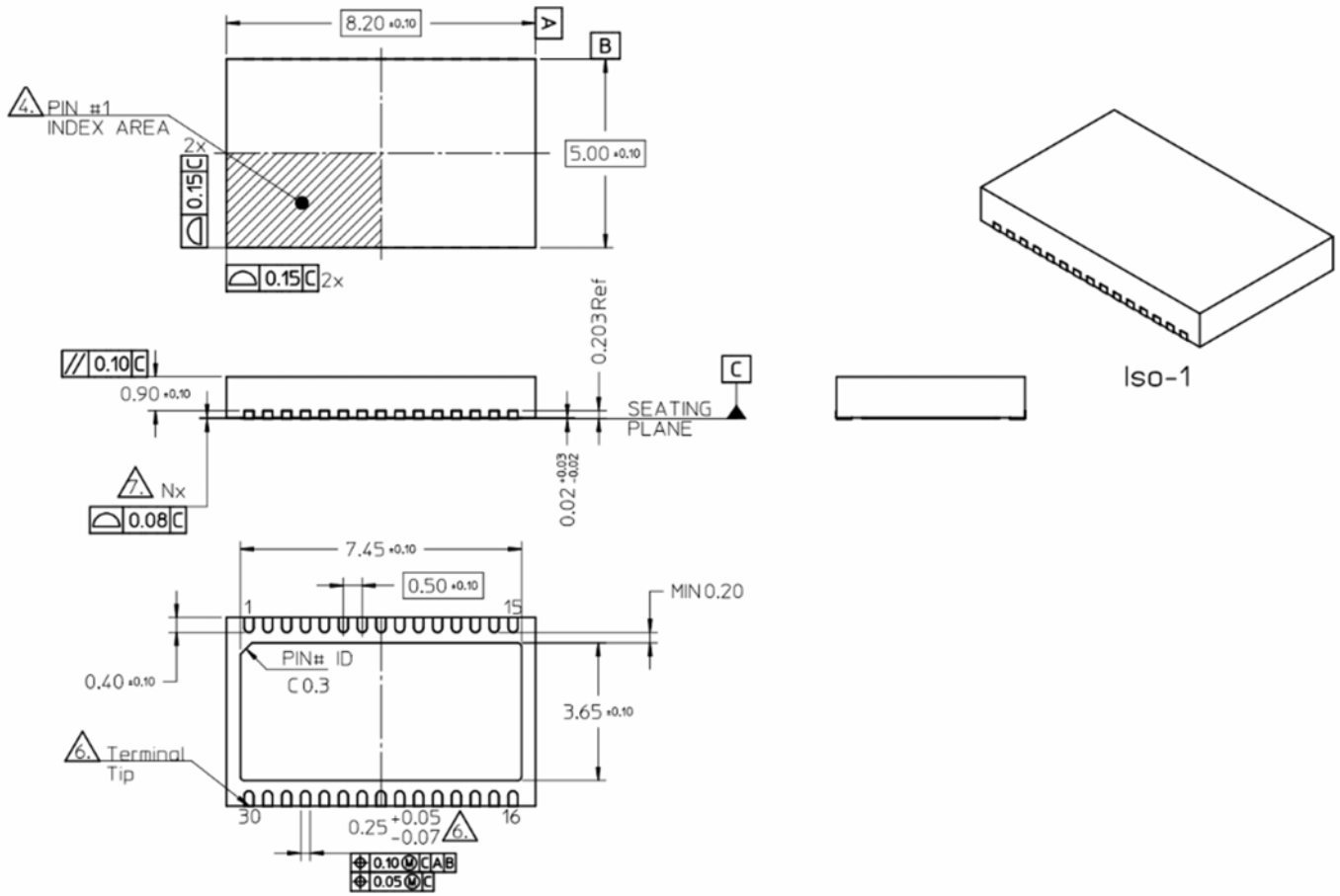

Product Ordering Information

Ordering Part Number	Product Description	Package	Delivery Form
AEAT-9988M-D30	High-accuracy magnetic encoder, 16 bits MT and 23 bits ST, SSI SPI RS-485	DFN 30 leads, 8.2 mm × 5 mm	Tube, 44 pieces
AEAT-9988M-102	High-accuracy magnetic encoder, 16 bits MT and 23 bits ST, SSI SPI RS-485	DFN 30 leads, 8.2 mm × 5 mm	Tape and Reel, 100 pieces
AEAT-9988M-104	High-accuracy magnetic encoder, 16 bits MT and 23 bits ST, SSI, SPI, RS-485	DFN 30 leads, 8.2 mm × 5 mm	Tape and Reel, 500 pieces
AEAT-9988MB-D30	High-accuracy magnetic encoder, 16 bits MT and 23 bits ST, SSI, SPI, RS-485, BiSS-C	DFN 30 leads, 8.2 mm × 5 mm	Tube, 44 pieces
AEAT-9988MB-102	High-accuracy magnetic encoder, 16 bits MT and 23 bits ST, SSI, SPI, RS-485, BiSS-C	DFN 30 leads, 8.2 mm × 5 mm	Tape and Reel, 100 pieces
AEAT-9988MB-104	High-accuracy magnetic encoder, 16 bits MT and 23 bits ST, SSI, SPI, RS-485, BiSS-C	DFN 30 leads, 8.2 mm × 5 mm	Tape and Reel, 500 pieces
HEDS-9988MEVB	AEAT-9988M SSI, SPI, RS-485 Evaluation Board	—	1 piece per box
HEDS-9988MBEVB	AEAT-9988MB SSI, SPI, RS-485, BiSS-C Evaluation Board	—	1 piece per box
HEDS-9988PRGEVB	AEAT-9988MB Programming Kit with 2 units of evaluation board HEDS-9988MBEVB, 1 set of hub ring magnet, and 1 set of magnet without hub	—	1 set

Copyright © 2024 Broadcom. All Rights Reserved. The term “Broadcom” refers to Broadcom Inc. and/or its subsidiaries. For more information, go to www.broadcom.com. All trademarks, trade names, service marks, and logos referenced herein belong to their respective companies.

Broadcom reserves the right to make changes without further notice to any products or data herein to improve reliability, function, or design. Information furnished by Broadcom is believed to be accurate and reliable. However, Broadcom does not assume any liability arising out of the application or use of this information, nor the application or use of any product or circuit described herein, neither does it convey any license under its patent rights nor the rights of others.

Mouser Electronics

Authorized Distributor

Click to View Pricing, Inventory, Delivery & Lifecycle Information:

[Broadcom Limited:](#)

[AEAT-9988MB-104](#) [AEAT-9988M-102](#) [AEAT-9988MB-102](#) [HEDS-9988PRGEVB](#) [HEDS-9988MBEVB](#) [AEAT-9988M-104](#) [AEAT-9988MB-D30](#) [HEDS-9988MEVB](#) [AEAT-9988M-D30](#)