

AEAT-901B Series

256 to 10000 CPR Incremental Magnetic Encoder

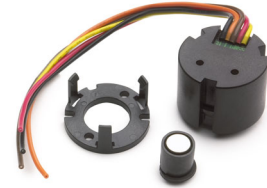

Overview

The Broadcom[®] AEAT-901B Series is a series of Incremental Magnetic Encoders that provide an integrated solution for angular detection within a complete 360° rotation. The use of magnetic technology for motion control and sensing activities eliminates mechanical contact and enables this device to be free from mechanical wear and tear. The three-channel output provides an additional index channel for every full rotation or revolution of 360°. An additional advantage is that the encoder's upper rotational speed limit is limited by the application's bearing speed.

Exploded View

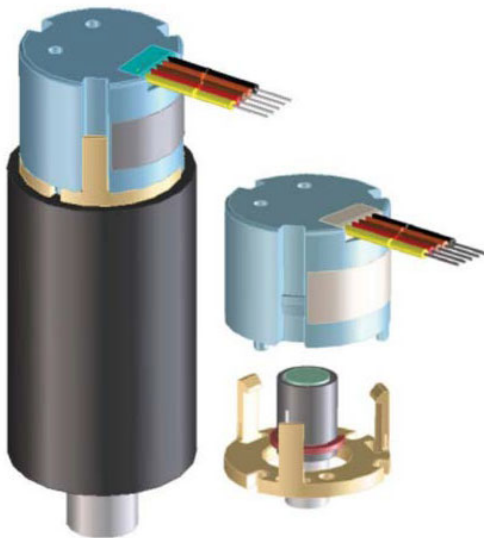

Features

- Resolution of 256 to 10,000 cycles per revolution (CPR)
- Contactless sensing technology
- Wide temperature range from -40°C to +125°C
- 3-channel output
- Single 5V supply
- Easy assembly and no signal adjustment required
- Direct connectivity through cable output
- RoHS compliant

Applications

- Speed detection
- Knob control
- Rotary encoder

NOTE: This product is not specifically designed or manufactured for use in any specific device. Customers are solely responsible for determining the suitability of this product for its intended application and solely liable for all loss, damage, expense, or liability in connection with such use.

Table 1: Device Selection Guide^a

Part Number	Resolution (CPR)	Operating Temperature (°C)	Output Communication	DC Supply Voltage (V)
AEAT-901B-F06	256	-40 to +125	Incremental	+5.0
AEAT-901B-I06	512	-40 to +125	Incremental	+5.0
AEAT-901B-J06	1024	-40 to +125	Incremental	+5.0
AEAT-901B-U06	2048	-40 to +125	Incremental	+5.0
AEAT-901B-R06	4096	-40 to +125	Incremental	+5.0
AEAT-901B-E06	200	-40 to +125	Incremental	+5.0
AEAT-901B-G06	360	-40 to +125	Incremental	+5.0
AEAT-901B-H06	400	-40 to +125	Incremental	+5.0
AEAT-901B-A06	500	-40 to +125	Incremental	+5.0
AEAT-901B-M06	800	-40 to +125	Incremental	+5.0
AEAT-901B-B06	1000	-40 to +125	Incremental	+5.0
AEAT-901B-T06	2000	-40 to +125	Incremental	+5.0
AEAT-901B-W06	2500	-40 to +125	Incremental	+5.0
AEAT-901B-Z06	5000	-40 to +125	Incremental	+5.0
AEAT-901B-P06	10000	-40 to +125	Incremental	+5.0

a. For other options of magnetic encoders, refer to factory.

Table 2: Absolute Maximum Ratings^{a, b}

Parameter	Symbol	Limits	Unit	Notes
DC Supply Voltage at Pin $V_{DD} = 5V$	V_{DD}	-0.3 to +6	V	
Input Voltage	V_I	-0.3 to $V_{DD} + 0.3$	V	
Storage Temperature	T_{STG}	-40 to +125	°C	

a. Stresses greater than those listed under Absolute Maximum Ratings may cause permanent damage to the device. This is stress rating only and functional operation of the device at these or any other conditions above those indicated in the operational sections of this specification is not implied.

b. Exposure to absolute maximum rating conditions for extended periods may affect reliability.

Table 3: Recommended Operating Conditions^{a,b,c}

Parameter	Symbol	Limits	Unit	Notes
DC Supply Voltage at Pin $V_{DD} = 5V$	V_{DD}	+4.5/+5.5	V	
Operating Temperature	T_A	-40 to +125	°C	
Rotational Speed	Mechanical	12000	RPM	
	Electrical	7000	RPM	

a. Under recommended mounting and tolerance, and mechanical shaft play, the incremental encoder's quadrature output (quarter cycle phase shift between Channel-A and Channel-B) is always maintained. The dynamic performance of the encoder output is depicted in the figures in the [Encoding Characteristics](#) section.

b. The magnetic incremental output has a fixed hysteresis of 0.08 degrees for all different CPR options.

c. The quadrature decoding of both the Channel-A and Channel-B would ensure that the incremental counts are maintained even when there is transition noise due to fluctuation of the magnetic field strength.

The DC characteristics over recommended operating range; typical at 25°C.

Table 4: DC Characteristics

Parameter	Symbol	Values			Unit	Notes
		Min.	Typ.	Max.		
V _{DD} Supply Current	I _{DD}	—	22	26	mA	
Output High Voltage D0	V _{OH}	V _{DD} - 0.5	—	—	V	
Output Low Voltage D0	V _{OL}	—	—	V _{SS} + 0.4	V	
Output Current D0	I _O	—	—	4	mA	V _{DD} pin = 4.5V

Table 5: Environmental Specifications

Parameter	Reference Standard	Test Conditions	Level
Electromagnetic Compatibility (EMC) ^a			
Electrostatic Discharge (ESD) Immunity	IEC/EN 61000-4-2	4kV	
Power Frequency Magnetic Field Immunity	IEC/EN 61000-4-8	30 A/m (continuous field) 300 A/m (short duration field)	Level 4
Pulse Magnetic Field Immunity	IEC/EN 61000-4-9	1000 A/m	Level 5
Damped Oscillatory Magnetic Field Immunity	IEC/EN 61000-4-10	100 A/m	Level 5
Mechanical Durability			
Vibration (Operating)	IEC/EN 60068-2-6	10 Hz to 500 Hz at 5G	
Shock	IEC/EN 60068-2-27	6 ms at 200G	

a. Suitable for applications in Industrial Environment Class 4.

Package Dimensions

Figure 1: Package and Recommended Mounting Dimensions

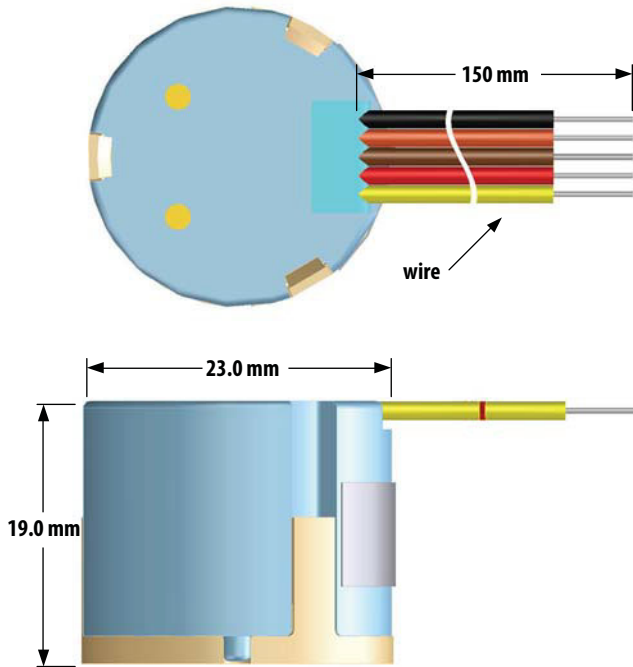
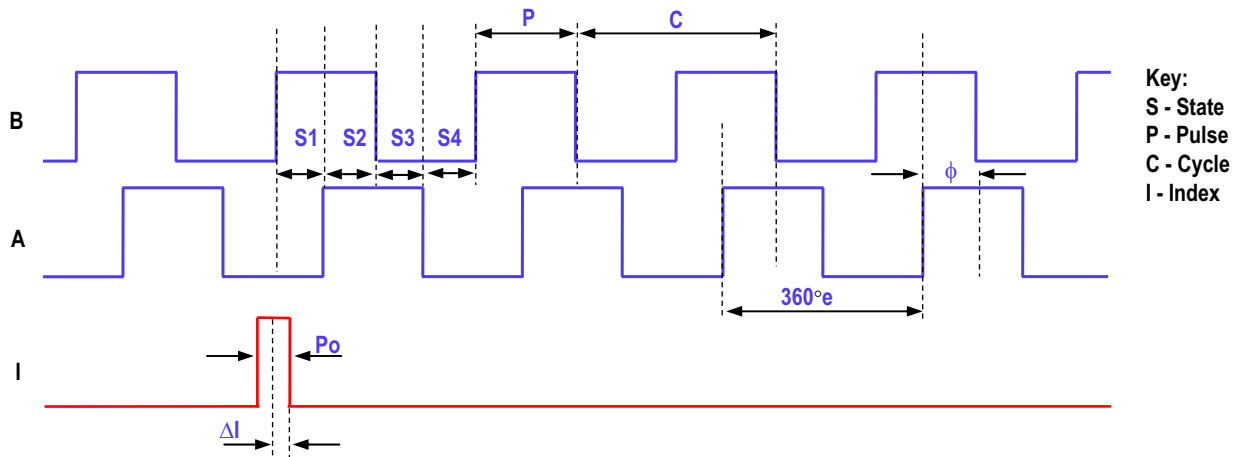

Table 6: Mechanical Parameters

No.	Parameter	Value
1	Operating Temperature	-40°C to +125°C
2	Shaft Axial Play	±0.08 mm
3	Shaft TIR	0.05 mm
4	Maximum Mechanical Speed	12,000 rpm
5	Shaft Diameter	6 mm +0/-0.01 mm
6	Moment Inertia	0.104 g-cm ²
7	Shaft Length	8.5 mm ± 1.0 mm
8	Mounting Screw Size (mm)	M2 x 0.4 x 8 (socket head cap screw, head Ø3.8 ± 0.18 mm)
9	Recommended Screw Torque	0.6 lb.inch
10	Encoder Base Plate Thickness	2 mm
11	Bolt Circle	±0.13

Encoding Characteristics

Figure 2: Incremental Output Waveform



NOTE: Channel-B leads Channel-A by 90 °e in a clockwise direction (top view of the encoder), and Channel-A leads Channel-B by 90 °e in an anti-clockwise direction.

Figure 3: Typical Cycle Error over Speed

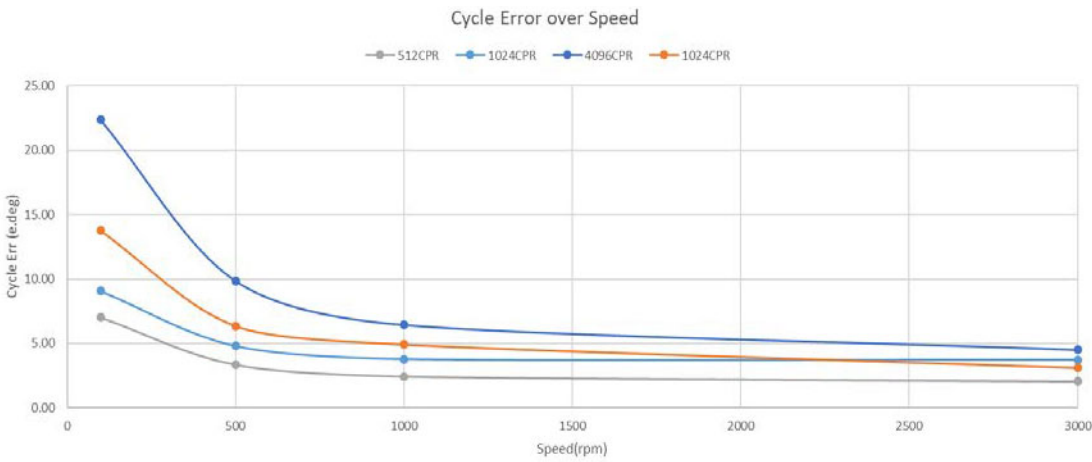

Figure 4: Typical Duty Error over Speed

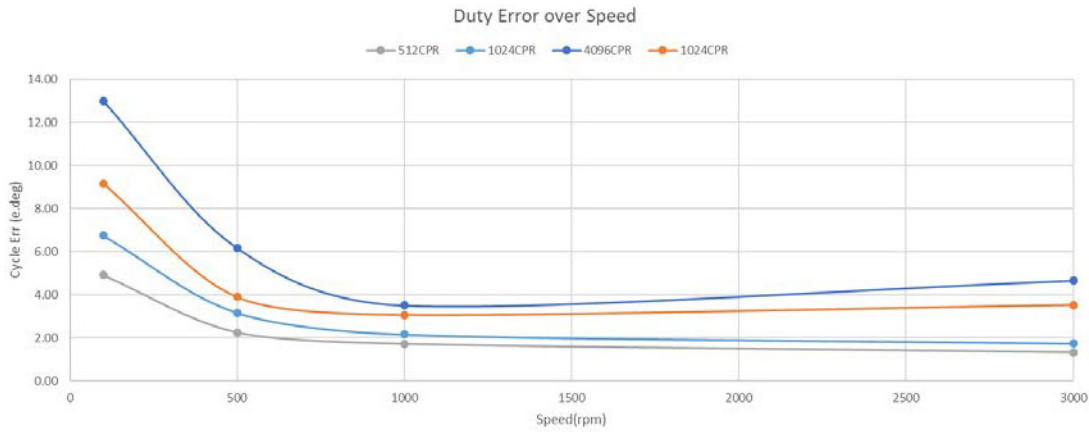
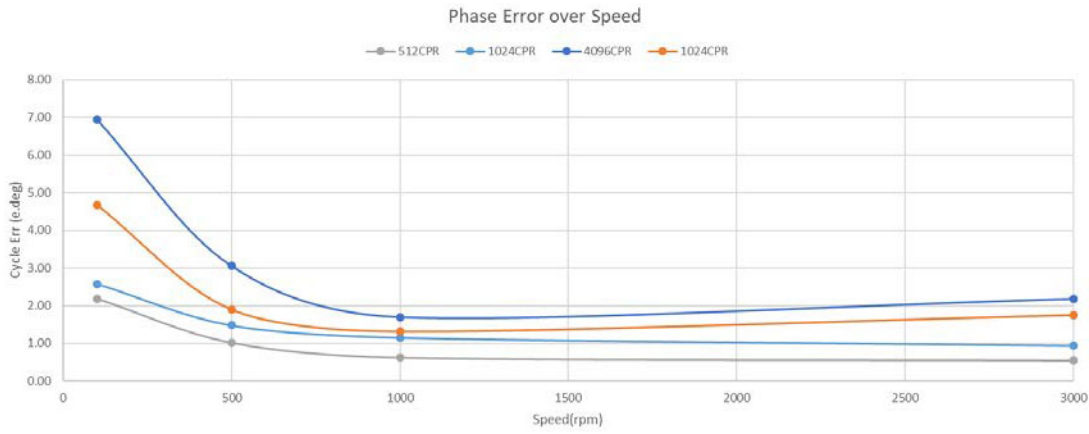
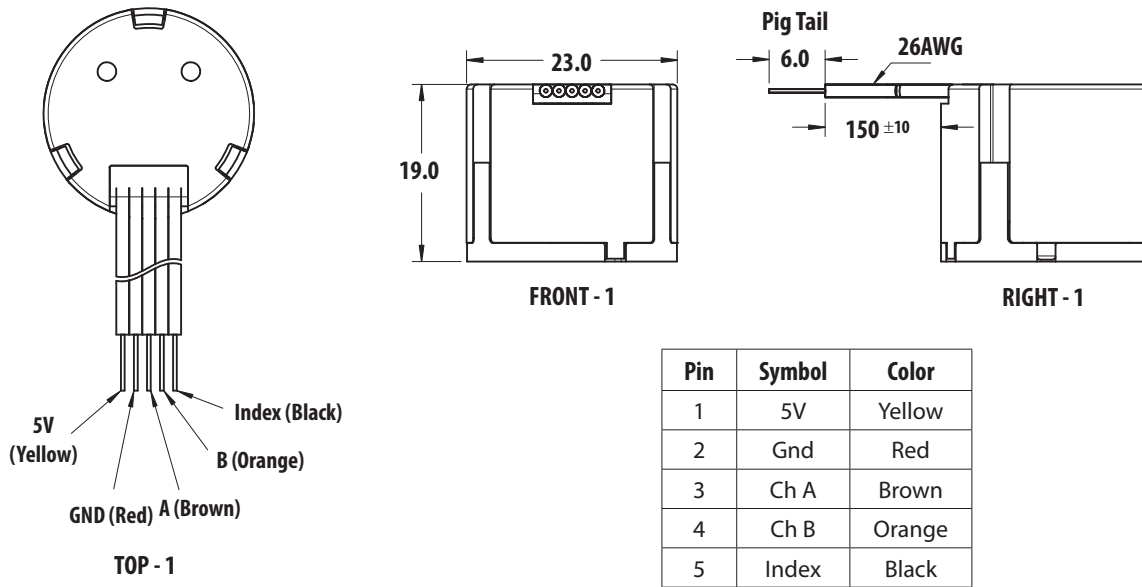

Figure 5: Typical Phase Error over Speed



Electrical Connections

Figure 6: Electrical Connection by Wire Color



Alignment Tool Set – Part Number HEDS-8934

This optional alignment tool set consists of a gap setting plate and a centering jig. Refer to Application Note 5317 for the assembly guide.

Figure 7: Accessories - HEDS-8934, A Set of Optional Centering and Gap Setting Jigs (available for purchase separately)

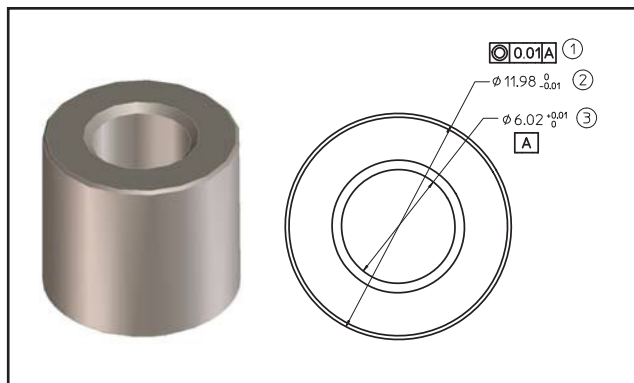
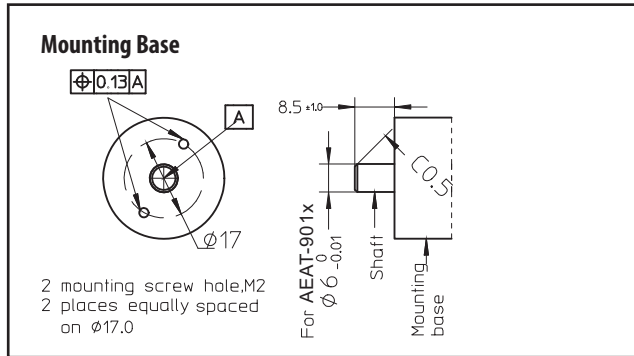

Optional - Centering Jig
(Refer to Application Note for details)

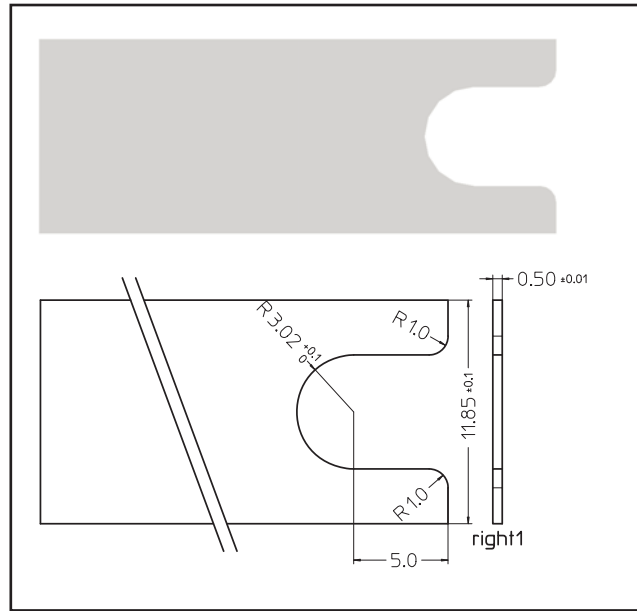

Optional - Base Gap Setting Plate
(Refer to Application Note for details)

Copyright © 2024 Broadcom. All Rights Reserved. The term “Broadcom” refers to Broadcom Inc. and/or its subsidiaries. For more information, go to www.broadcom.com. All trademarks, trade names, service marks, and logos referenced herein belong to their respective companies.

Broadcom reserves the right to make changes without further notice to any products or data herein to improve reliability, function, or design. Information furnished by Broadcom is believed to be accurate and reliable. However, Broadcom does not assume any liability arising out of the application or use of this information, nor the application or use of any product or circuit described herein, neither does it convey any license under its patent rights nor the rights of others.

Mouser Electronics

Authorized Distributor

Click to View Pricing, Inventory, Delivery & Lifecycle Information:

[Broadcom Limited:](#)

[AEAT-901B-A06](#) [AEAT-901B-R06](#) [AEAT-901B-T06](#) [AEAT-901B-B06](#) [AEAT-901B-P06](#) [AEAT-901B-I06](#) [AEAT-901B-F06](#) [AEAT-901B-G06](#) [AEAT-901B-J06](#) [AEAT-901B-E06](#) [AEAT-901B-Z06](#) [AEAT-901B-H06](#) [AEAT-901B-U06](#)
[AEAT-901B-W06](#) [AEAT-901B-M06](#) [AEAT-901B-N06](#) [AEAT-901B-V06](#)