

DO NOT SCALE DRAWING WORK TO FIGURE

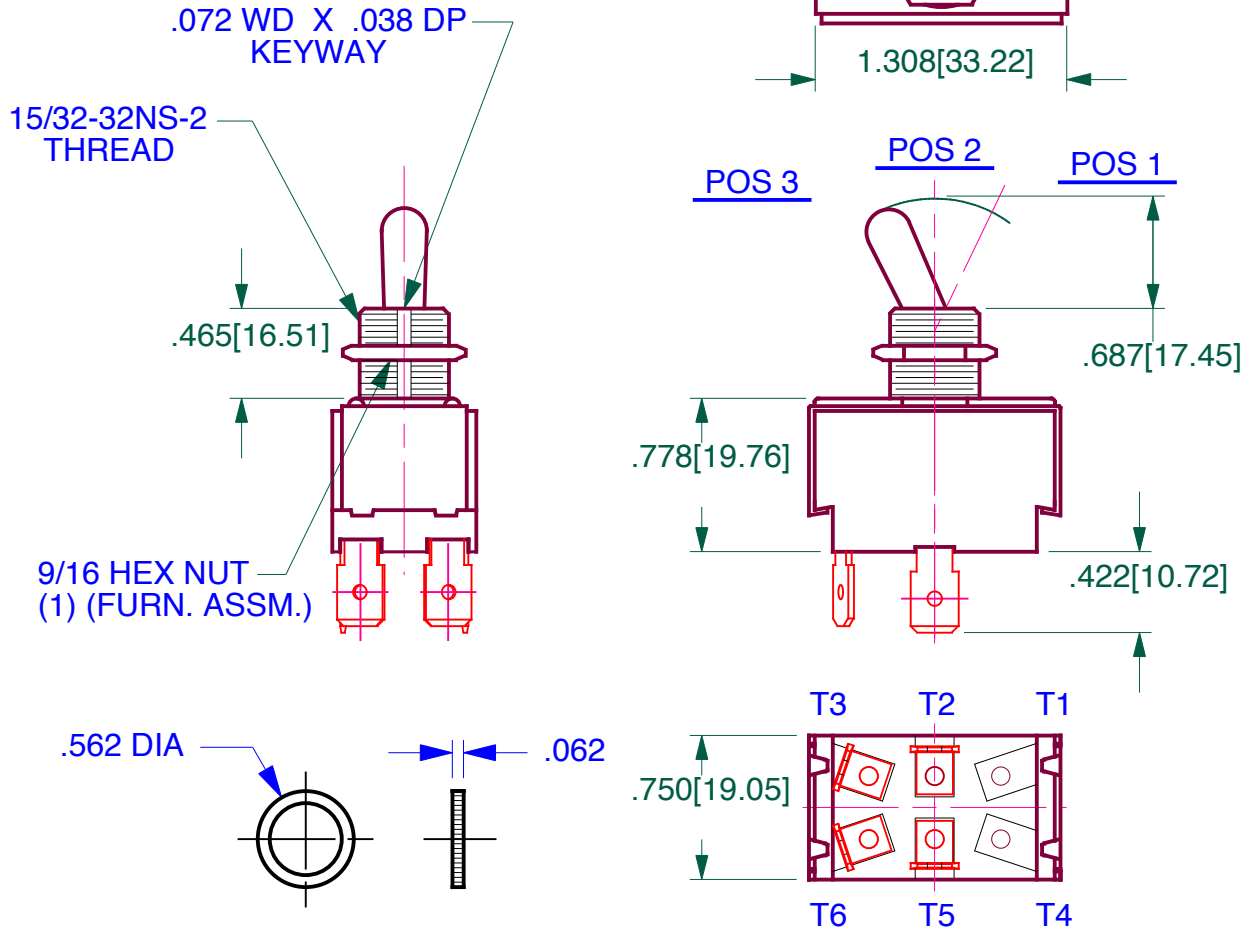

DWG NO.		6GG5B-73	REV.	01
LET	REVISIONS		DATE	
01	RELEASED		3-2-09	

<u>RATING:</u>	UL & CSA
10AMP	<u>250VAC</u>
15AMP	125VAC
1/2HP	<u>250VAC</u>

<u>OPERATES:</u>		
<u>POSITIONS OF TOGGLE</u>		
<u>POS 1</u>	<u>POS 2</u>	<u>POS 3</u>
(ON)	ON	OFF
T2 TO 3	T5 TO 6	
T5 TO 6		

NOTES:

- 1- KEYWAY INDICATES DOWN POSITION
- 2- TOGGLE, BUSHING, RING NUT & HEX NUT ARE NICKEL PLATED BRASS
- 3- .250 TAB TERMINALS

DIMENSIONS SUBJECT TO CHANGE WITHOUT NOTICE		FINISH _____	Carling Technologies Innovative Designs. Powerful Solutions.	
PROPRIETARY NOTE: NOTICE TO ALL PERSONS RECEIVING THIS DRAWING. THIS DOCUMENT IS THE PROPERTY OF CARLING TECHNOLOGIES, INC. AND IS NOT TO BE DISCLOSED, REPRODUCED IN WHOLE OR IN PART OR USED FOR MANUFACTURING PURPOSES BY ANYONE WITHOUT THE CONSENT OF CARLING TECHNOLOGIES, INC.	UNSPECIFIED TOLERANCES		TITLE	
	FRAC. ±1/64 X.XXX ±.015 ANGLES ±1°		G SERIES DOUBLE POLE	
	PROJECTIONS	DIMENSIONS IN [mm]	SIZE	DWG NO.
			A	6GG5B-73
		APPD BY	DATE	REV.
				01
			USED ON _____	SCALE: NONE
				SHT 1 OF 1

Mouser Electronics

Authorized Distributor

Click to View Pricing, Inventory, Delivery & Lifecycle Information:

[Carling Technologies:](#)

[6GG5B-73](#)