

3 • ROW Connectors

Sandwich- Boards

WGAV-WGA

WGAV122PD9SY

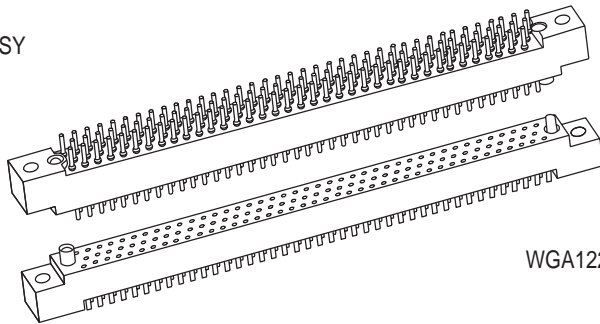

WGA122SACSY

Examples:

PLUG: WGAV 122 PD9 SY
RECEPTACLE: WGA 122 SAC SY

PLUG

RECEPTACLE

SERIES

WGAV = 3-row, straight, plug, mounting ears

WGA = 3-row, straight, receptacle, mounting ears
WGA = 3-row, right-angle, receptacle, mounting ears

NUMBER OF CONTACTS

122

122

TYPE OF CONTACTS

- Pin or contact can be used in either receptacle.
- When pin contacts are used, standard hardware orientation places the female hardware next to the #1 position.
- When socket contacts are used, standard hardware orientation places the male hardware next to the #1 socket position.

PC = Pin, straight, solder cup
PD7 = Pin, straight, dip solder, .109
PD9 = Pin, straight, dip solder, .140
PD11 = Pin, straight, dip solder, .172
PD15 = Pin, straight, dip solder, .234
PF6 = Pin, straight, flex-circuit, .093

SAC = Socket, straight, solder cup
SAD7 = Socket, straight, dip solder, .109
SAD9 = Socket, straight, dip solder, .140
SAD11 = Socket, straight, dip solder, .172
SAF3 = Socket, straight, flex-circuit, .050
SAF6 = Socket, straight, flex-circuit, .093
SAF9 = Socket, straight, flex-circuit, .140
SAP = Socket, straight, pin termination, .150, connector saver
SAW24 = Socket, straight, wire wrap, .375
SAW40 = Socket, straight, wire wrap, .625
SOR7 = Socket, right-angle, dip solder, .109, see page W-51.
SOR9 = Socket, right-angle, dip solder, .140, see page W-51.
SOR11 = Socket, right-angle, dip solder, .172, see page W-51.

TYPE OF HARDWARE

- Plug facial seal gaskets and hoods; order separately or add "Q" in part number. Example: WGAV122PD9QJ. See "Gaskets" and "Hoods" under next tab for instructions.

SY = Guide Set
SY-# = Guide Set, polarized
SYL = Guide Set, long
JT = Turning jackset, .460
JTA = Turning jackset, .160
JTB = Hex turning jackset, .160
JTC = Turning jackset, .460

SY = Guide Set
SY-# = Guide Set, polarized
SYL = Guide Set, long
J = Fixed jackset
JL = Fixed jackset, long

OPTIONS

- OPTION CODES: Add to the end of the part number. Example: WGAV122PD9SY-D01. Call factory for additional codes.
- B82: Termination face sealed against conformal coating.
- 342: Remove .250 mounting ears.
- D01: Pre-tin contact terminations. (Solder cup, wire wrap and flex circuit contacts are excluded.)
- G69: Solder cups are fixed in an outward orientation, otherwise contacts can rotate.

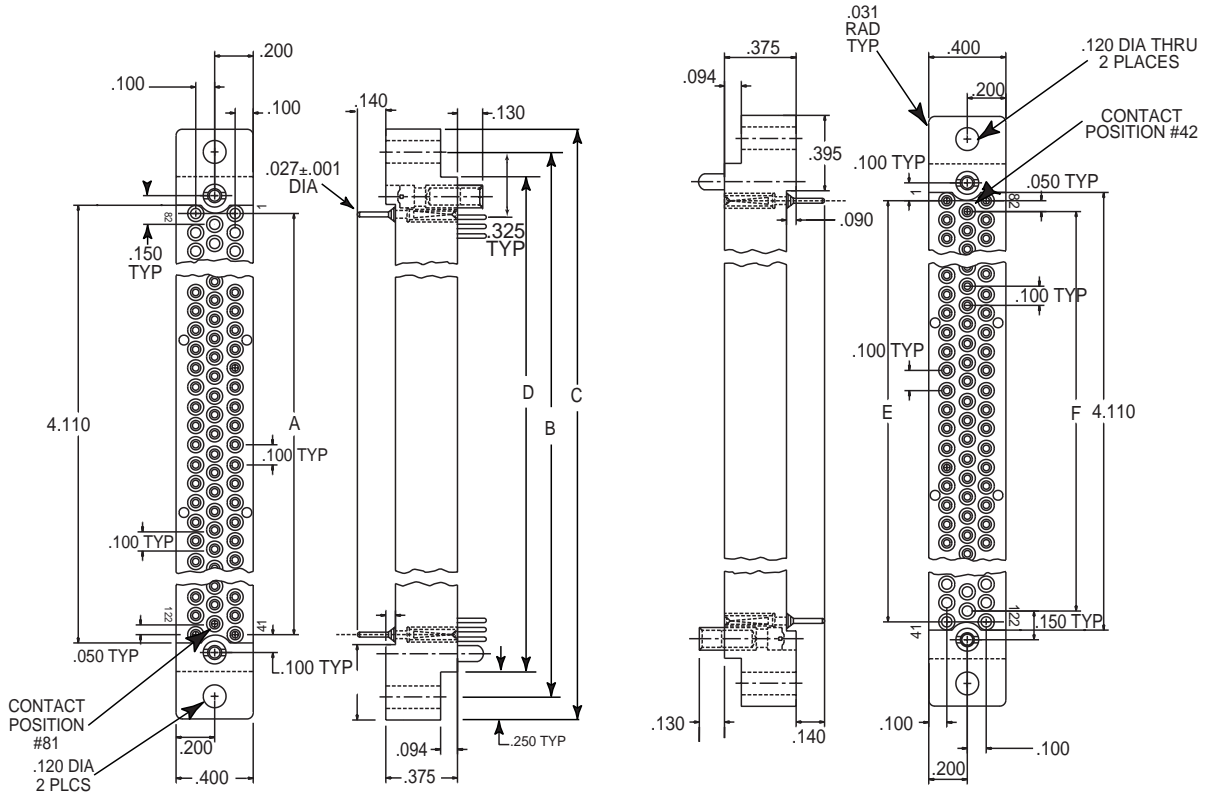

PLUG
 EXAMPLE: WGAV122PD9SY

RECEPTACLE
 EXAMPLE: WGA122SAD9SY

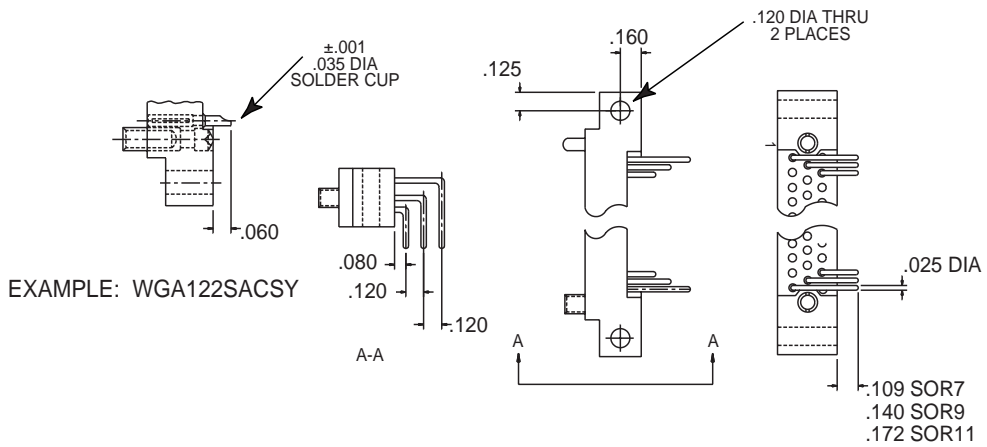

EXAMPLE: WGA122SACSY

EXAMPLE: WGA122SOR9SY

WGAV-WGA Dimensions

SIZE	A	B	C	D	E	F
122	4.200	4.650	4.900	4.400	4.000	3.900

Mouser Electronics

Authorized Distributor

Click to View Pricing, Inventory, Delivery & Lifecycle Information:

[AirBorn:](#)

[WGA122SAW40](#)