



4-Channel, Automotive Class D Audio Amplifier

General Description

The MAX13301 combines four high-efficiency Class D amplifiers with integrated diagnostic hardware for reliable automotive audio systems, and delivers up to 80W at 10% THD+N per channel into 4Ω when operating from a 24V supply.

The internal diagnostics evaluate each channel's output impedance to check for shorts across the outputs, to the battery, or to ground. The I²C interface allows the system to query critical device parameters such as device temperature and output clipping. The device is programmable to four different I²C addresses.

The audio amplifiers feature single-ended analog inputs with a common negative input. The MAX13301 has a fixed gain of 26dB.

The Class D amplifier has 10 programmable switching frequencies between 300kHz and 750kHz.

The BTL outputs are protected against short circuits and thermal overload. The outputs can be configured as a 2-, 3-, or 4-channel amplifier. The device provides 50V load-dump protection, and is offered in the thermally enhanced, 48-pin TSSOP-EPR package operating over the -40°C to +125°C temperature range.

Applications

Car Stereo
Rear-Seat Entertainment Units
Discrete Amplifier Modules
Active Loudspeaker Systems
Radio Head Units
Mobile Surround Systems

Typical Operating Circuit appears at end of data sheet.

Features

- ◆ **High Output Power (10% THD+N)**
 - ◇ 2 x 160W into 2Ω at 24V
 - ◇ 4 x 80W into 4Ω at 24V
- ◆ **2 Channels Can Be Paralleled**
- ◆ **Feedback After the Filter**
 - ◇ Improves THD+N
 - ◇ Low Output Impedance
 - ◇ High-Frequency Response
 - ◇ Improved Damping of Complex Loads
 - ◇ Enables Low-Cost Inductors
- ◆ **102dB SNR**
- ◆ **Low 0.04% THD+N**
- ◆ **70dB PSRR**
- ◆ **On-Board Diagnostics**
 - ◇ Short-to-Battery/GND
 - ◇ Open/Shorted Load
 - ◇ Tweeter Detect
- ◆ **Protection and Monitoring Functions:**
 - ◇ Short-Circuit Protection
 - ◇ 50V Load-Dump Protection
 - ◇ Programmable Clip Detection
 - ◇ DC Offset Detection
 - ◇ Open Battery/GND Tolerant
 - ◇ Thermal-Overload Protection
 - ◇ Thermal Warning Indication
- ◆ **Four-Address I²C Control Interface**
- ◆ **Low-Power Shutdown Mode**
- ◆ **Up to 90.5% Efficiency**
- ◆ **-40°C to +125°C Ambient Operating Temperature**
- ◆ **48-Pin TSSOP-EPR (Top Side Exposed Pad) Package**
- ◆ **AEC-Q100 Qualified**

Ordering Information

PART	PIN-PACKAGE	SUPPLY VOLTAGE RANGE (V)
MAX13301AUM/V+	48 TSSOP-EPR*	6 to 25.5

Note: The device operates over the -40°C to +125°C operating temperature range.

V denotes an automotive qualified part.

+ Denotes a lead(Pb)-free/RoHS-compliant package.

*EPR = Top side exposed pad.

4-Channel, Automotive Class D Audio Amplifier

ABSOLUTE MAXIMUM RATINGS

PVDD to PGND.....	-0.3V to +30V	MUTE_CL1, $\overline{\text{CLO}}$, $\overline{\text{FLT_OT}}$, EN to GND.....	-0.3V to +6V
PVDD to PGND (t < 200ms).....	-0.3V to +50V	IN_ to GND.....	-0.3V to +6V
PVDD Ramp Rate	25V/ms	GND to PGND.....	-0.3V to +0.3V
VDD5, CM to PGND.....	-0.3V to +6V	Continuous Power Dissipation (Notes 1 and 2)	
CP to PGND	(VPVDD - 0.3V) to (VCHOLD + 0.3V)	TSSOP (derate 16.7mW/°C above 70°C).....	1333.3mW
CHOLD to PVDD	-0.3V to +6V	Operating Temperature Range.....	-40°C to +125°C
OUT_ to PGND, FB_ to PGND	-0.3V to (VPVDD + 0.3V)	Junction Temperature Range.....	-40°C to +150°C
VDD to GND.....	-0.3V to +6V	Storage Temperature Range.....	-65°C to +150°C
REF to GND.....	-0.3V to +6V	Lead Temperature (soldering, 10s).....	+300°C
SCL, SDA, SYNC to GND.....	-0.3V to +6V	Soldering Temperature (reflow)	+240°C

Stresses beyond those listed under "Absolute Maximum Ratings" may cause permanent damage to the device. These are stress ratings only, and functional operation of the device at these or any other conditions beyond those indicated in the operational sections of the specifications is not implied. Exposure to absolute maximum rating conditions for extended periods may affect device reliability.

PACKAGE THERMAL CHARACTERISTICS (Notes 1 and 2)

TSSOP

Junction-to-Ambient Thermal Resistance (θ_{JA}) 60°C/W

Junction-to-Case Thermal Resistance (θ_{JC}) 1°C/W

Note 1: Package thermal resistances were obtained using the method described in JEDEC specification JESD51-7, using a four-layer board. For detailed information on package thermal considerations, refer to www.maxim-ic.com/thermal-tutorial.

Note 2: The 48-pin TSSOP-EPR package has a top side exposed pad for enhanced thermal management. Connect this exposed pad to an external heatsink to ensure the device is adequately cooled. The maximum power dissipation in the device is a function of this external heatsink and other system parameters. See the *Thermal Information* section for more information.

ELECTRICAL CHARACTERISTICS

(VPVDD = 14.4V, VDD = VDD5 = 5V, VGND = VPGND = 0V, fsw = 500kHz, MAP.COMP[2:0] = (see Table 20 for applicable setting), TA = -40°C to +125°C; typical values are at TA = +25°C, unless otherwise noted.) (Note 3)

PARAMETER	SYMBOL	CONDITIONS	MIN	TYP	MAX	UNITS
AMPLIFIER DC CHARACTERISTICS						
Supply Voltage Range	VPVDD	Operational	8		25.5	V
			6			
	VDD5	4.75	5	5.5		
	VDD	4.5	5	5.5		
PVDD UVLO Threshold		Falling	5.2	5.35	5.6	V
PVDD OVLO Threshold		Rising	26	27	30	V
PVDD OVLO Response Timing		Rising	4	14	55	μs
OUT_ and FB_ Voltage		OV active	VPVDD/2			V
VDD UV Threshold		Falling		4.2	4.35	V
		Rising		4.5	4.6	
VDD UV Threshold Hysteresis			0.1	0.2		V
VDD UV Threshold Deglitch				1		μs
Quiescent Supply Current	IPVDD	RL = ∞, play mode (CTRL2 = 0x0F)		70		μA
	IVDD5			60	72	mA
	IVDD			50	75	

4-Channel, Automotive Class D Audio Amplifier

ELECTRICAL CHARACTERISTICS (continued)

(VPVDD = 14.4V, VDD = VDD5 = 5V, VGND = VPGND = 0V, fsw = 500kHz, MAP.COMP[2:0] = (see Table 20 for applicable setting), TA = -40°C to +125°C; typical values are at TA = +25°C, unless otherwise noted.) (Note 3)

PARAMETER	SYMBOL	CONDITIONS	MIN	TYP	MAX	UNITS
PVDD Shutdown Supply Current	IPVDD_SHDN	TA = +25°C, VEN = 0V		7		μA
		TA = TMIN to +85°C, VEN = 0V			17	
VDD5 Shutdown Supply Current	IVDD5_SHDN	TA = +25°C, VEN = 0V		0.1		μA
		TA = TMIN to +85°C, VEN = 0V			2	
VDD Shutdown Supply Current	IVDD_SHDN	TA = +25°C, VEN = 0V		0.1		μA
		TA = TMIN to +85°C, VEN = 0V			2	
Standby Supply Current	IVDD5	CTRL2 = 0x20, VEN = 5V		1		mA
	IVDD			10		
Output Leakage		VOUT_ = 14.4V			200	μA
		VOUT_ = 0V			1	
Output Discharge Current		CTRL3.DIS = 1		8		mA
RDS(ON) per Output		Excluding wire bond resistance		70		mΩ
FB_ Resistance				310		kΩ
Output Offset	VOS	TA = +25°C, mute mode (CTRL2 = 0x00), no input signal			15	mV
		TA = TMIN to TMAX			100	
OUT_ Output Impedance				100		mΩ
AMPLIFIER AC CHARACTERISTICS						
Output Power	POUT	THD+N = 1%, RL = 4Ω, VPVDD = 24V		66		W
		THD+N = 10%, RL = 4Ω, VPVDD = 24V		80		
		THD+N = 10%, RL = 2Ω, VPVDD = 24V, parallel mode		160		
Signal-Path Gain				26		dB
Channel-to-Channel Gain Tracking			-1	+0.1	+1	dB
Input Resistance		IN0+, IN1+, IN2+, IN3+		20		kΩ
		IN-		5		
Mute Attenuation		Guaranteed by design, test is functional only	90	100		dB
Precharge Current		CTRL1.PRE = 1	IN-	5	10	mA
			IN_+	1	2	
Power-Supply Rejection Ratio		VDD = 4.5V to 5.5V		70		dB
		VPVDD = 1Vp-p ripple, 100Hz to 10kHz		60		
		VPVDD = 8V to 25.5V		68		
REF Voltage		CREF(MIN) = 1μF		2.224		V
REF Output Impedance		DC		800		Ω
Input Voltage Range		AC-coupled			1.2	VRMS

4-Channel, Automotive Class D Audio Amplifier

ELECTRICAL CHARACTERISTICS (continued)

(VPVDD = 14.4V, VDD = VDD5 = 5V, VGND = VPGND = 0V, fsw = 500kHz, MAP.COMP[2:0] = (see Table 20 for applicable setting), TA = -40°C to +125°C; typical values are at TA = +25°C, unless otherwise noted.) (Note 3)

PARAMETER	SYMBOL	CONDITIONS	MIN	TYP	MAX	UNITS	
Total Harmonic Distortion Plus Noise	THD+N	POUT = 10W, RL = 4Ω, BW = 22Hz to 20kHz AES17 filter, f = 1kHz		0.04	0.14	%	
		POUT = 1W to 10W, RL = 4Ω, BW = 22Hz to 20kHz AES17 filter, f = 1kHz		0.1			
Noise	N	A-weighted, VPVDD = 24V		100		μVRMS	
		22Hz to 22kHz, VPVDD = 24V		140			
		A-weighted, CTRL5.SS[2:0] = 110, SSEN = 1, VPVDD = 24V		100			
Crosstalk		POUT_ = 4W, f = 1kHz to 10kHz		60		dB	
Efficiency	η	RL = 4Ω, POUT = 20W/channel, VDD5, VDD supplied from a switching power supply		88		%	
Internal Switching Frequency Adjust Range		6 to 15 clock-divider range	300		750	kHz	
ONE-TIME DIAGNOSTICS							
Short-to-Ground Detection		CTRL2.STBY = 0, CTRL3.SDET = 1		75		Ω	
Short-to-PVDD Detection Threshold		CTRL2.STBY = 1, CTRL3.SDET = 1		6		V	
Open-Load Detection		CTRL3.LDM = 1, power amplifier mode	70	100		Ω	
		CTRL3.LDM = 0, line-driver mode	200	300			
Low-Current Threshold		15kHz < f < 25kHz, TA = +25°C, CTRL3.TW = 1	CTRL3.HCL = 0	160	291	500	mA
			CTRL3.HCL = 1	200	364	625	
High-Current Threshold		f < 20Hz, CTRL3.TW = 0	CTRL3.HCL = 0	0.65	1.15	1.85	A
			CTRL3.HCL = 1	0.9	1.65	2.15	
CONTINUOUS DIAGNOSTICS							
Differential Output Offset Voltage Threshold		No audio in play mode	0.56	1.04	1.6	V	
Clip-Detect Threshold		RL = 4Ω	CTRL1.CLVL[1:0] = 11	1		%THDN	
			CTRL1.CLVL[1:0] = 01	3			
			CTRL1.CLVL[1:0] = 10	5			
			CTRL1.CLVL[1:0] = 00	10			

4-Channel, Automotive Class D Audio Amplifier

ELECTRICAL CHARACTERISTICS (continued)

(VPVDD = 14.4V, VDD = VDD5 = 5V, VGND = VPGND = 0V, fsw = 500kHz, MAP.COMP[2:0] = (see Table 20 for applicable setting), TA = -40°C to +125°C; typical values are at TA = +25°C, unless otherwise noted.) (Note 3)

PARAMETER	SYMBOL	CONDITIONS	MIN	TYP	MAX	UNITS
Short-to-Ground/PVDD		OUT__ shorted to ground/PVDD, CTRL1.CL_TH = 1	CTRL3.HCL = 0	1.03		A
			CTRL3.HCL = 1	1.28		
		OUT__ shorted to ground/PVDD, CTRL1.CL_TH = 0	CTRL3.HCL = 0	3.09		
			CTRL3.HCL = 1	3.86		
Level 1 Output Current Limit	ILIM1	CTRL3.HCL = 0	5.5	7		A
Level 2 Output Current Limit	ILIM2	CTRL3.HCL = 1	7	8.75		A
THERMAL PROTECTION						
Thermal Warning Range 1		Guaranteed monotonic		110		°C
Thermal Warning Range 2		Guaranteed monotonic		120		°C
Thermal Warning Range 3		Guaranteed monotonic		130		°C
Thermal Warning Range 4		Guaranteed monotonic		140		°C
Thermal Shutdown Level		Guaranteed monotonic	150	165		°C
Thermal Warning Hysteresis				5		°C
Thermal Shutdown Hysteresis			15			°C
CHARGE PUMP						
Switching Frequency		fCP = fsw	300		750	kHz
Soft-Start Time				100		µs
Charge-Pump Output Impedance		Guaranteed by FET RDS(ON) measurement		1.8		Ω
Output Voltage				VPVDD + 5		V
INTERNAL OSCILLATOR						
SYNC I/O Frequency Range		2x switching frequency	0.6		1.5	MHz
Frequency		Spread-spectrum disabled	17.1	18	18.9	MHz
DIGITAL INTERFACE (SCL, SDA, ADDR, CL0, MUTE_CL1, EN, SYNC, FLT_OT)						
SYNC High		CTRL1.CM[1:0] = 01, ISOURCE = 3mA	4.5			V
SYNC Low		CTRL1.CM[1:0] = 01, ISINK = 3mA			0.4	V
Input Voltage High	VINH		2.0			V
Input Voltage Low	VINL				0.8	V
Input Voltage Hysteresis				300		mV
Input Leakage Current		SDA, SCL, CL0, MUTE_CL1, FLT_OT			±10	µA
Output Low Voltage		SDA, CL0, MUTE_CL1, ISINK = 3mA, FLT_OT			0.4	V
Pulldown Current		MUTE_CL1		5	13	µA
		EN		10	18	

4-Channel, Automotive Class D Audio Amplifier

ELECTRICAL CHARACTERISTICS (continued)

(VPVDD = 14.4V, VDD = VDD5 = 5V, VGNDD = VPGND = 0V, fsw = 500kHz, MAP.COMP[2:0] = (see Table 20 for applicable setting), TA = -40°C to +125°C; typical values are at TA = +25°C, unless otherwise noted.) (Note 3)

PARAMETER	SYMBOL	CONDITIONS	MIN	TYP	MAX	UNITS
I²C TIMING						
Output Fall Time	t _{OF}	CBUS = 10pF to 400pF			250	ns
Pin Capacitance					10	pF
Clock Frequency	f _{SCL}				400	kHz
SCL Low Time	t _{LOW}		1.3			μs
SCL High Time	t _{HIGH}		0.6			μs
START Condition Hold Time	t _{HD:STA}	Repeated START condition	0.6			μs
START Condition Setup Time	t _{SU:STA}	Repeated START condition	0.6			μs
Data Hold Time	t _{HD:DAT}		0		900	ns
Data Setup Time	t _{SU:DAT}		100			ns
Input Rise Time	t _R	SCL, SDA			300	ns
Input Fall Time	t _F	SCL, SDA			300	ns
STOP Condition Setup Time	t _{SU:STO}		0.6			μs
Bus Free Time	t _{BUF}	Between START and STOP conditions	1.3			μs
Maximum Bus Capacitance	CBUS	Per bus line			400	pF

Note 3: All units are 100% production tested at TA = +25°C. All temperature limits are guaranteed by design.

4-Channel, Automotive Class D Audio Amplifier

Typical Operating Characteristics

(VPVDD = 24V, VDD = VDD5 = 5V, VGND = VPGND = 0V, fsw = 500kHz, MAP.COMP[2:0] = 011, see Table 32 for LC filter value, TA = +25°C, unless otherwise noted.)

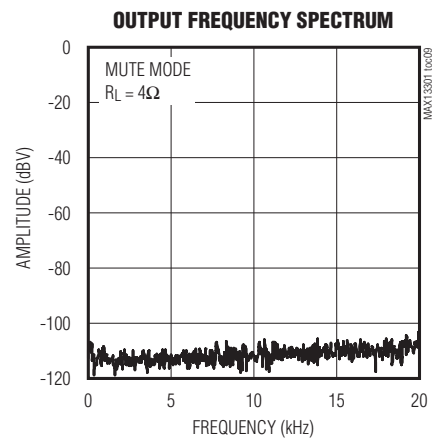
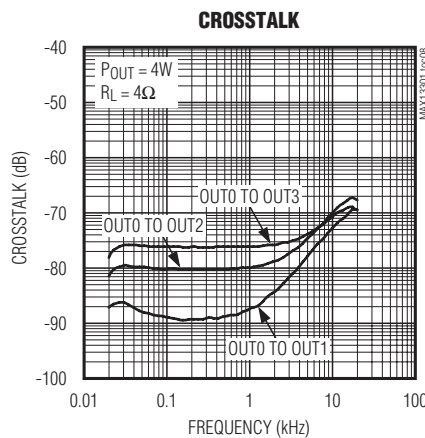
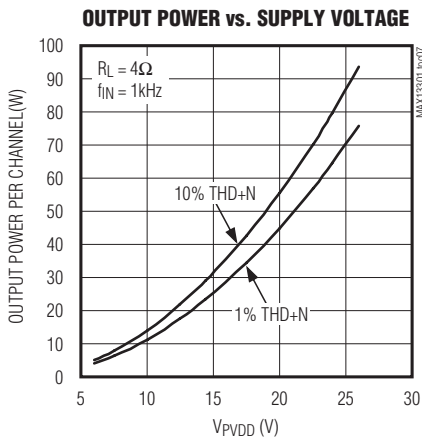
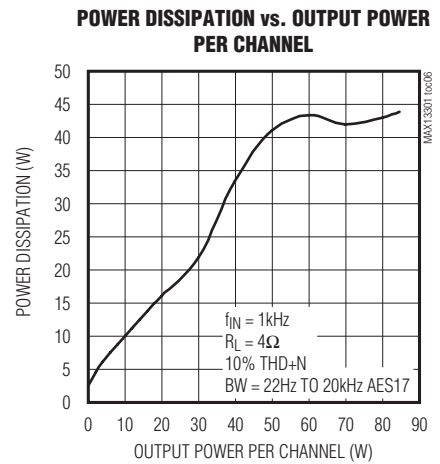
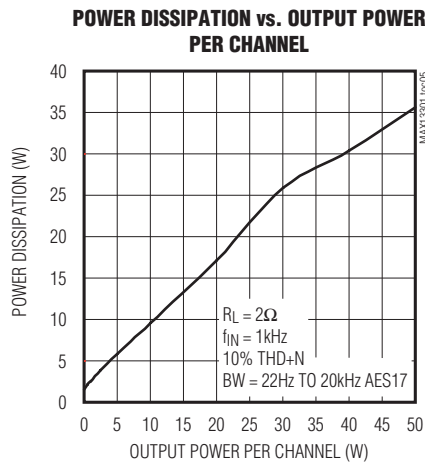
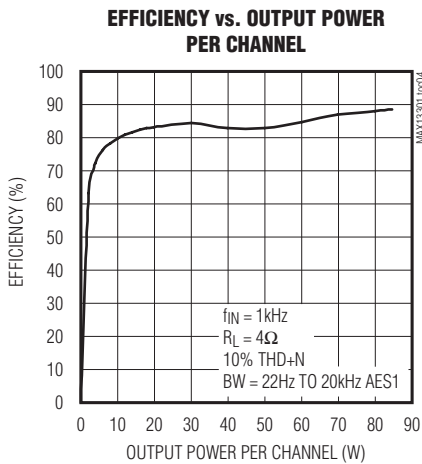
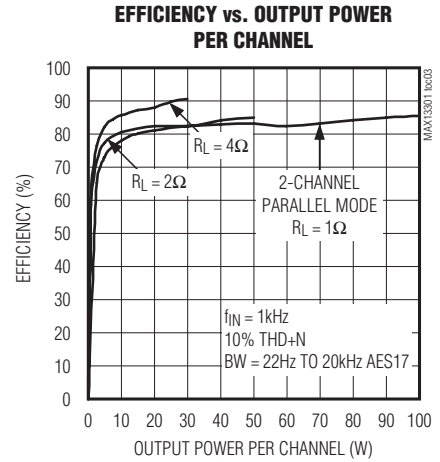
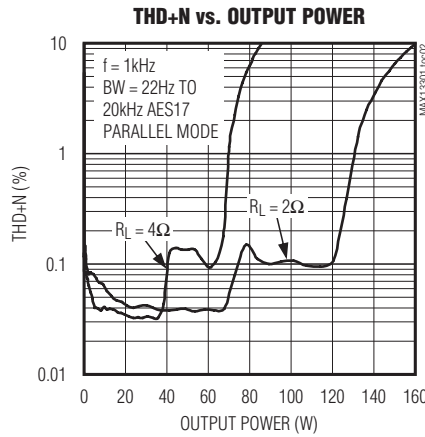
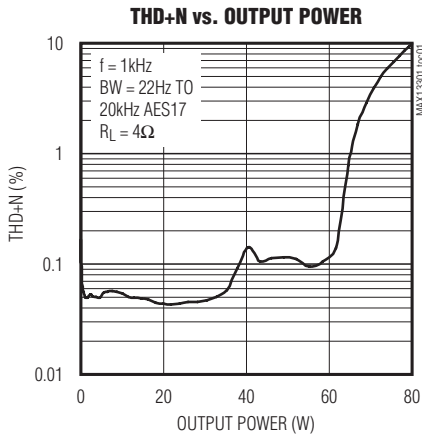

4-Channel, Automotive Class D Audio Amplifier

Typical Operating Characteristics (continued)

(VPVDD = 24V, VDD = VDD5 = 5V, VGND = VPGND = 0V, fsw = 500kHz, MAP.COMP[2:0] = 011, see Table 32 for LC filter value, TA = +25°C, unless otherwise noted.)

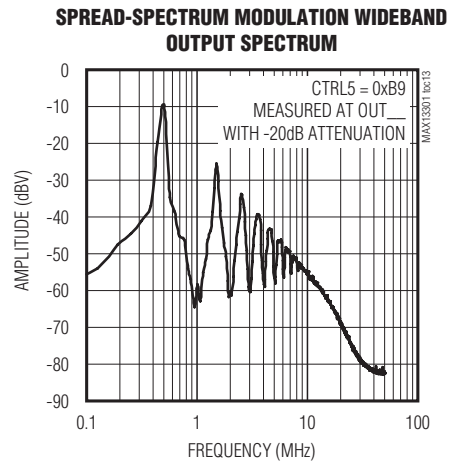
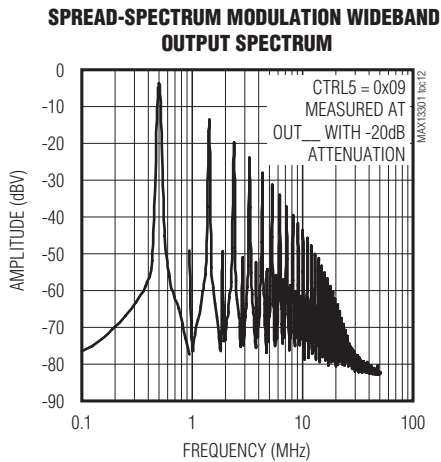
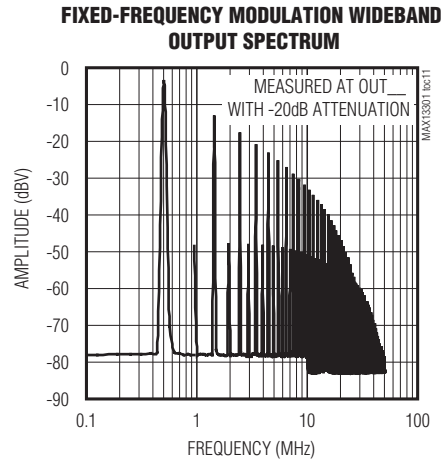
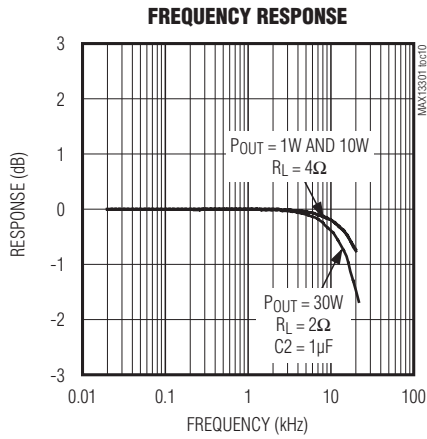

4-Channel, Automotive Class D Audio Amplifier

Pin Configuration

MAX13301

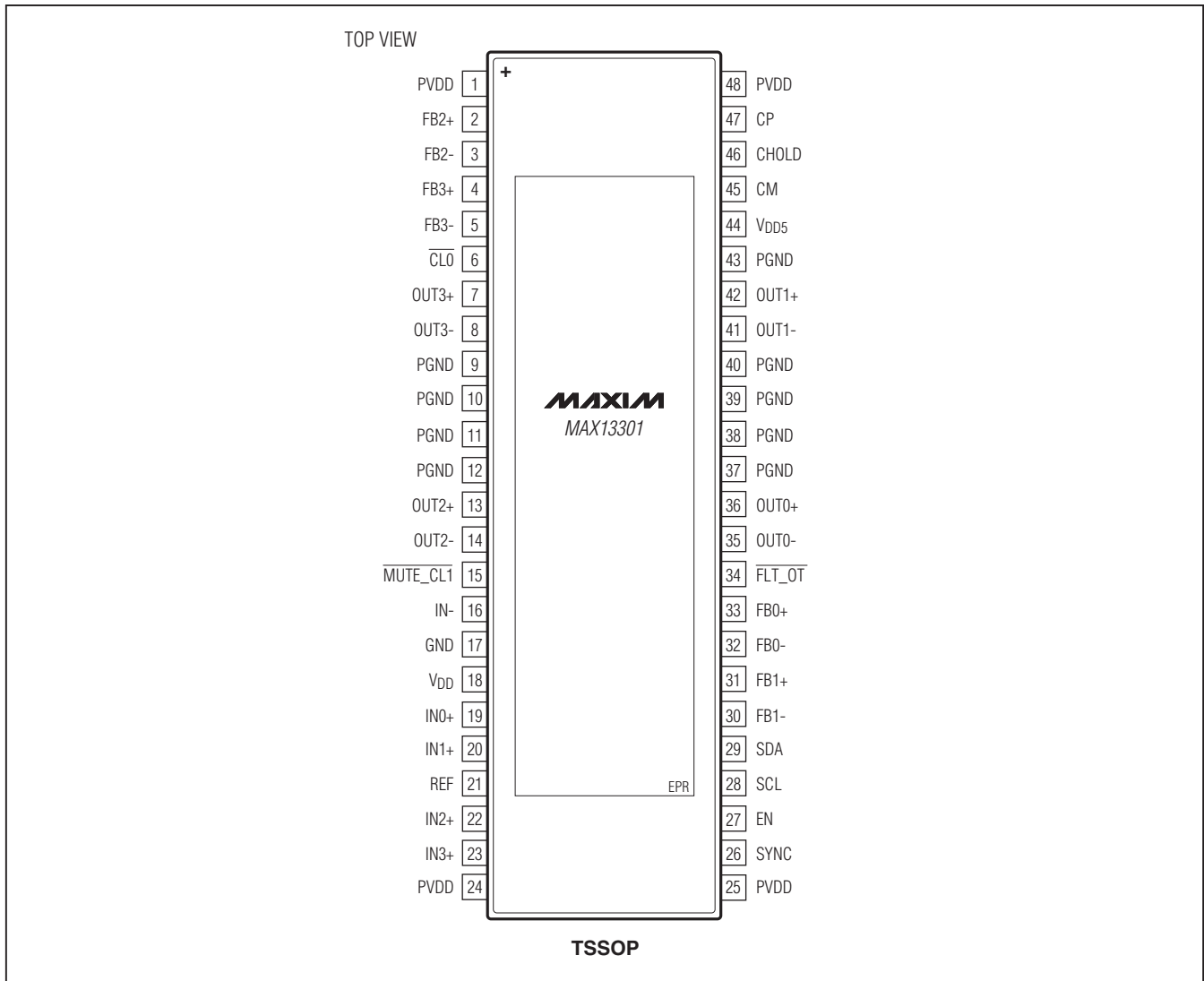

Pin Description

PIN	NAME	FUNCTION
1, 24, 25, 48	PVDD	Audio Output Power-Supply Input. Bypass each PVDD to its PGND pair locally with 0.1 μ F and 4.7 μ F ceramic capacitors. Each PVDD/PGND pair consists of one PVDD and two PGNDs. The PVDD/PGND pairs are 1 and 9-10, 48 and 39-40, 24 and 11-12, and 25 and 37-38. Bypassing PVDD locally minimizes the area of di/dt loops. An additional 1000 μ F, low-ESR electrolytic capacitor should be placed from 1 and 48 to PGND and 24 and 25 to PGND.
2	FB2+	Output 2 Positive Feedback. Connect to the LC filter's positive output through a 150 Ω \pm 1% resistor.
3	FB2-	Output 2 Negative Feedback. Connect to the LC filter's negative output through a 150 Ω \pm 1% resistor.

4-Channel, Automotive Class D Audio Amplifier

Pin Description (continued)

PIN	NAME	FUNCTION
4	FB3+	Output 3 Positive Feedback. Connect to the LC filter's positive output through a 150Ω ±1% resistor.
5	FB3-	Output 3 Negative Feedback. Connect to the LC filter's negative output through a 150Ω ±1% resistor.
6	$\overline{\text{CL0}}$	Active-Low Open-Drain Clip 0 Output. $\overline{\text{CL0}}$ is configurable to provide clipping indication for outputs 0 and 1 or for all four outputs.
7	OUT3+	Channel 3 Power Amplifier Positive Output
8	OUT3-	Channel 3 Power Amplifier Negative Output
9–12, 37–40, 43	PGND	Audio Output Power Ground
13	OUT2+	Channel 2 Power Amplifier Positive Output
14	OUT2-	Channel 2 Power Amplifier Negative Output
15	$\overline{\text{MUTE_CL1}}$	Mute Input or Active-Low Open-Drain Clip 1 Output. $\overline{\text{MUTE_CL1}}$ is configurable as a mute input or as an open-drain clip indicator output. When configured as an input, drive $\overline{\text{MUTE_CL1}}$ low to mute all four outputs. As an output, $\overline{\text{MUTE_CL1}}$ provides clipping indication for outputs 2 and 3. This pin also selects the low bit of the I ² C address and is latched upon the rising edge of the EN pin. $\overline{\text{MUTE_CL1}}$ has an internal 5μA pulldown.
16	IN-	Common Audio Negative Input. IN- has 5kΩ of input resistance. Bypass to analog ground with 2μF or 4 × C _{IN+} .
17	GND	Analog Ground
18	V _{DD}	5V Analog Power-Supply Input. Bypass with a 2.2μF or larger ceramic capacitor to GND. V _{DD} provides power to the analog and digital circuitry.
19	IN0+	Channel 0 Audio Input. IN0+ has 20kΩ of input resistance. Connect a series capacitor of at least 0.47μF to IN0+.
20	IN1+	Channel 1 Audio Input. IN1+ has 20kΩ of input resistance. Connect a series capacitor of at least 0.47μF to IN1+.
21	REF	2.2V Reference Output. Bypass REF to GND with a 1μF ceramic capacitor.
22	IN2+	Channel 2 Audio Input. IN2+ has 20kΩ of input resistance. Connect a series capacitor of at least 0.47μF to IN2+.
23	IN3+	Channel 3 Audio Input. IN3+ has 20kΩ of input resistance. Connect a series capacitor of at least 0.47μF to IN3+.
26	SYNC	Sync I/O. In master mode, SYNC outputs a clock signal that is synchronized to that of the modulator. In slave mode, SYNC is a clock input and serves as the clock source for the modulator.
27	EN	Enable Input. Connect EN to V _{DD} for normal operation. Connect EN to GND to place the device in a low-power mode. There is an internal 10μA pulldown on EN.
28	SCL	I ² C Serial-Clock Input
29	SDA	I ² C Serial-Data Input and Output
30	FB1-	Output 1 Negative Feedback. Connect to the LC filter's negative output through a 150Ω ±1% resistor.
31	FB1+	Output 1 Positive Feedback. Connect to the LC filter's positive output through a 150Ω ±1% resistor.
32	FB0-	Output 0 Negative Feedback. Connect to the LC filter's negative output through a 150Ω ±1% resistor.
33	FB0+	Output 0 Positive Feedback. Connect to the LC filter's positive output through a 150Ω ±1% resistor.

4-Channel, Automotive Class D Audio Amplifier

Pin Description (continued)

PIN	NAME	FUNCTION
34	$\overline{\text{FLT_OT}}$	Active-Low Open-Drain Fault and Overtemperature Output. $\overline{\text{FLT_OT}}$ provides indication of faults, overtemperature, and thermal shutdown status.
35	OUT0-	Channel 0 Power Amplifier Negative Output
36	OUT0+	Channel 0 Power Amplifier Positive Output
41	OUT1-	Channel 1 Power Amplifier Negative Output
42	OUT1+	Channel 1 Power Amplifier Positive Output
44	VDD5	5V Power-Supply Input. Bypass with a 0.1 μ F capacitor to PGND. VDD5 provides power to the gate drivers and charge pump.
45	CM	Charge-Pump Capacitor Negative Terminal
46	CHOLD	Charge-Pump Output. Connect a 1 μ F capacitor from CHOLD to PVDD.
47	CP	Charge-Pump Capacitor Positive Terminal
—	EPR	Top Side Exposed Pad. Connect this exposed pad to an external heatsink to ensure the device is adequately cooled. The maximum power dissipation in the device is a function of this external heatsink and other system parameters. See the <i>Thermal Information</i> section for more information. The top side exposed pad is electrically isolated from the die.

Functional Diagram

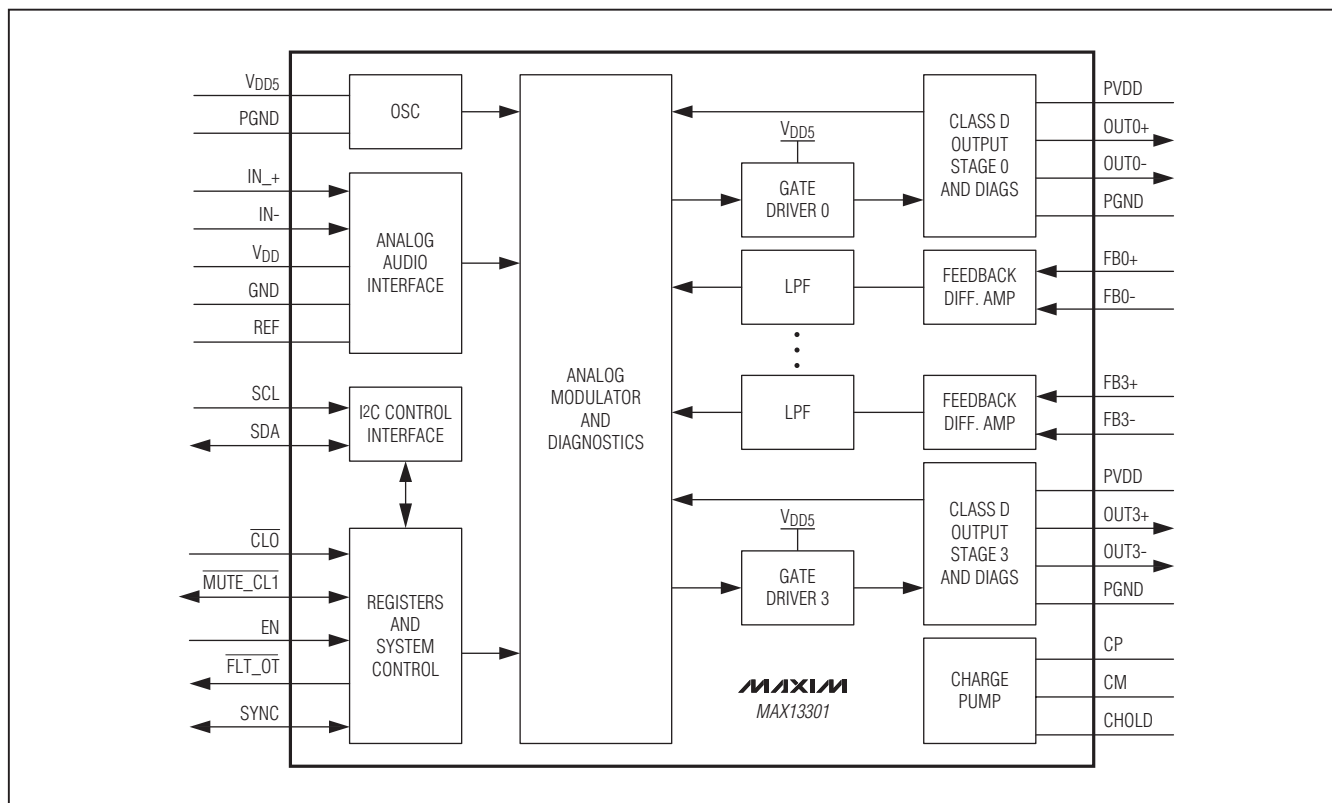

4-Channel, Automotive Class D Audio Amplifier

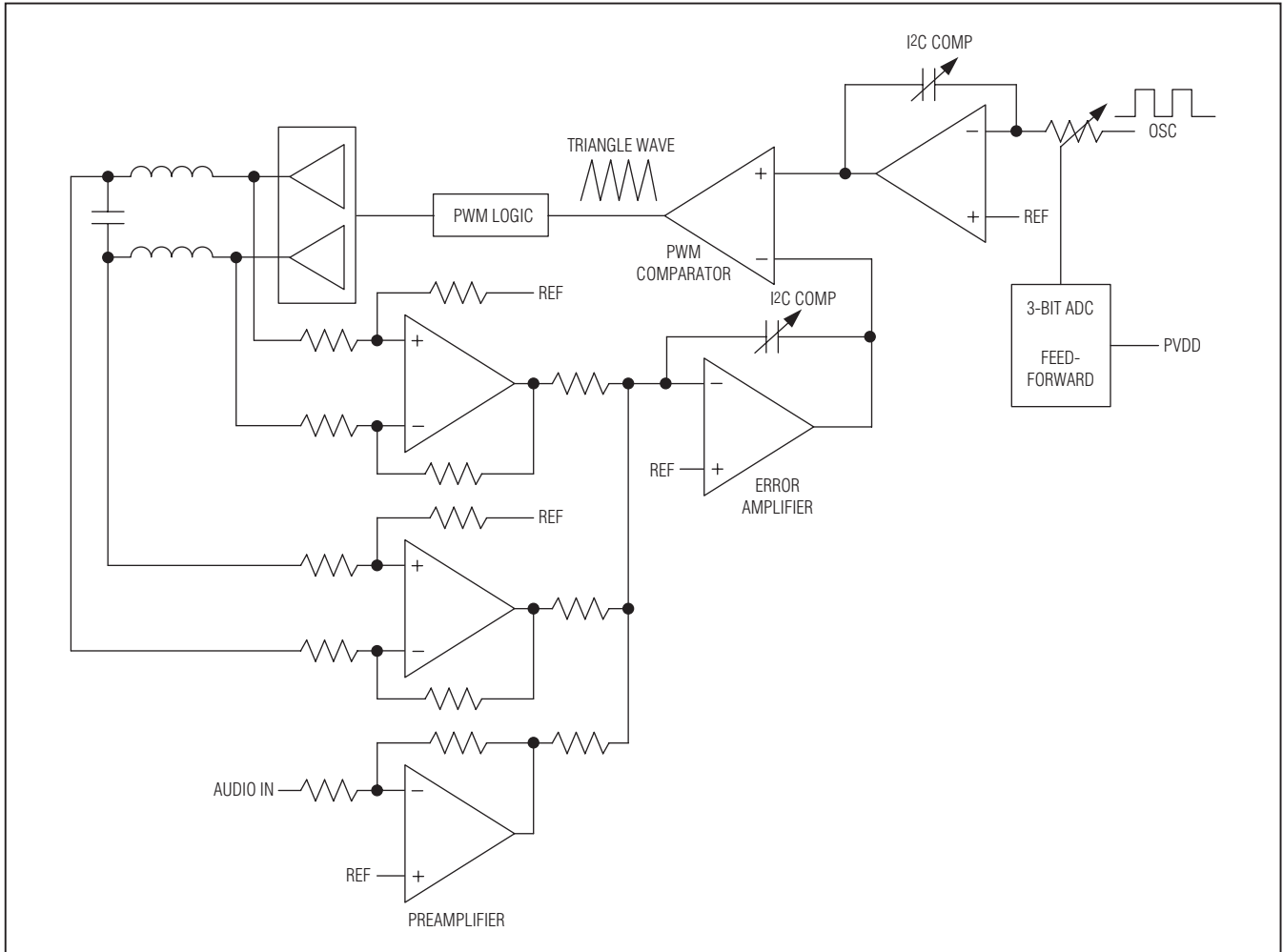

Figure 1. Detailed Block Diagram of the MAX13301 Audio Path

Detailed Description

The MAX13301 4-channel, Class D audio power amplifiers is specifically designed for automotive applications. Integrated feedback from the LC filter's output improves the THD+N by reducing the distortion, providing Class AB performance while achieving efficiency up to 90.5%. The devices also support spread-spectrum modulation for AM radio compatibility.

Description of Operation

The device emulates current-mode controllers with digital feed-forward (Figure 1). The internal oscillator creates an 18MHz square wave. The I²C controls a clock divider that divides down this high-frequency clock to a usable frequency. The resulting square wave is integrated to create

a triangle wave. A 3-bit ADC converts the PVDD voltage into a code that adjusts the resistors used in the triangle-wave integrator. The triangle-wave amplitude becomes progressively larger as PVDD increases. The triangle wave is fed into the PWM comparator.

The two differential amplifiers provide both analog and digital feedback. The feedback is summed with the output of the preamplifier at the error amplifier. The output of the error amplifier is an AC replica of the inductor current (emulated current mode) and the triangle wave is therefore the slope compensation. The PWM comparator controls the full-bridge operation, turning on and off each FET pair (double-edge modulation). To ensure that the devices switch at the desired frequency, it is important to ensure that the triangle wave is greater than the error-

4-Channel, Automotive Class D Audio Amplifier

amplifier ramp. The design equation that must be met to ensure constant frequency is as follows:

$$\text{Error-Amplifier Ramp} < 2/3 \text{ Triangle-Wave Ramp}$$

The error-amplifier ramp is fixed by the gain of the differential amplifiers used in the feedback loop and by the error-amplifier compensation capacitor programmed through I²C. To ensure the design equation for fixed frequency is met, the error-amplifier compensation capacitor tracks the integrator capacitor used to generate the triangle wave.

For optimal noise shaping, the error-amplifier capacitor should be set to a small value. This results in a broadband spectrum where the error amplifier pushes the noise created by the clock jitter and PWM sampling above the audio range. However, there is a limit. Because the triangle-wave capacitor tracks the error-amplifier capacitor, small capacitor values can clip the triangle wave as it runs out of supply. This effect is aggravated at high PVDD voltages by the ADC action that decreases the integrator resistor at higher supply voltages. Tables 20 and 21 are lookup tables to facilitate choosing the optimal setting for the error-amplifier capacitance (MAP.COMP[2:0]).

It is possible to change this setting instantaneously while playing music, but if there is no music, a slight audible click is heard at the speakers. Systems that monitor the input voltage can take advantage of this instantaneous programmability and use a smaller error-amplifier capacitor at lower PVDD voltages. Higher switching frequencies also allow the use of a smaller integrator capacitor, and thus help improve the noise performance of the amplifier.

Do not set the error-amplifier capacitor to a value less than 18pF. Doing so results in extreme distortion, as the triangle wave clips. The MAP.COMP[2:0] settings that result in this behavior are listed as reserved (Table 19).

Advantage of Feedback After the Filter

High-fidelity audio amplifiers require very low output impedance. The device achieves this by using a dual-

feedback approach. The digital feedback (feedback from OUT__ outputs) emulates current-mode enabling on chip compensation. The analog feedback (FB__ inputs) significantly reduces the output impedance of the amplifier and at the same time, compensates for the nonideal characteristics of the output filter. If the characteristics of the speaker and/or output filter change with age or temperature, the analog feedback compensates accordingly. Further inductor matching is less critical because the inductors are inside the feedback loop. Because the inductors are inside the feedback loop, the loop can dampen out any LC ringing that might occur when the amplifier is used as a line driver. The analog feedback is differential so it does not help with common-mode ringing. Thus, the Zobel (RC) networks are required on each speaker connection to damp any common-mode ringing associated with the LC output filter and speaker.

Operating Modes

Configure the device for one of three states of activity: normal, standby, or shutdown.

Normal

In normal mode, the device is ready for play. Placing the device in standby reduces power consumption while keeping fault monitors and the I²C interface on to communicate fault conditions. In shutdown, the device is completely disabled and draws minimal current from the battery.

To reset the device and clear all register contents to their reset values, set CTRL5.RST to 1. After reset, this bit is automatically cleared back to 0.

Standby

In standby, all circuitry is disabled except the fault monitors and the I²C interface. The I²C registers retain their content and are still interactive. To place the device in standby, set the CTRL2.STBY bit to 1. In standby, the device draws 11mA from all power-supply inputs.

Before exiting standby, always set the CTRL1.CL_TH (current-limit threshold setting) bit to 1. After exiting standby, clear CTRL1.CL_TH back to 0.

Table 1. Operating Modes

MODE	EN	CTRL2.STBY	I ² C	FAULT MONITORS	ALL OTHER CIRCUITRY
Normal	High	0	Enabled	On	On
Standby	High	1	Enabled	On	Off
Shutdown	Low	X	Off	Off	Off

X = Don't care

4-Channel, Automotive Class D Audio Amplifier

Shutdown

In shutdown, all circuitry including the fault monitors and I²C interface is disabled to reduce power consumption and extend battery life. Connect EN to logic-high for normal operation. Connect EN to GND to place the device in a low-power shutdown mode. In shutdown, the devices draw 17mA (typ) from the battery.

Clock Source

The device supports fixed-frequency modulation with an internal or external clock. The modulation mode is selected through CTRL1.CM[1:0] (operating mode select bits).

Master Configuration

In master mode, 10 modulation frequencies are available in fixed-frequency modulation mode. Program CTRL0.MDIV[3:0] (master clock-divide ratio bits) for the desired frequency.

Slave Configuration

Configuring the device as a slave allows an external clock source to provide the switching frequency. In this case, apply the external clock signal at SYNC at double the desired switching frequency.

Fixed-Frequency Modulation Mode

The device supports a fixed-frequency modulation mode with 10 different selectable frequencies between 300kHz and 750kHz. The frequency is selectable through the I²C interface. The frequency spectrum consists of the fundamental switching frequency and its associated harmonics (see the wideband output spectrum graphs in the *Typical Operating Characteristics*). For applications where exact spectrum placement of the switching fundamental is important, program the switching frequency so that the harmonics do not fall within a sensitive frequency band.

Spread Spectrum

The device features a unique spread-spectrum mode that flattens the wideband spectral components, improving EMI emissions that can be radiated by the speaker and cables. This feature is only available in master clock mode and is enabled by setting the CTRL5.SS[2:0] and CTRL5.SSEN bits. In spread-spectrum mode, the switching frequency varies linearly by up to 7% depending on CTRL5.SS[2:0] setting. The modulation scheme remains the same, but the period of the triangle waveform changes from cycle to cycle. Instead of a large amount of spectral energy present at multiples of the switching frequency, the energy is now spread over a bandwidth that increases with frequency. Above a few megahertz, the wideband spectrum looks like white noise for EMI

purposes. A proprietary amplifier topology ensures this does not significantly increase the noise floor in the audio bandwidth.

Efficiency

The high efficiency of a Class D amplifier is due to the switching operation of the output stage transistors. In a Class D amplifier, the output transistors act as current-steering switches and consume negligible additional power. Any power loss associated with the Class D output stage is mostly due to the I²R loss of the MOSFET on-resistance and quiescent current overhead. The theoretical best efficiency of a linear amplifier is 78% at peak output power. Under normal operating levels (typical music reproduction levels), the efficiency falls below 30%, whereas the device exhibits > 80% efficiency under the same conditions (Figure 2).

Current Limit

The current limit of the outputs is selectable between 7A (typ) and 8.75A (typ) through the CTRL3.HCL bit.

When the current limit is exceeded, the affected output is latched off and its corresponding overcurrent indicator bit OSTAT0.OC[3:0] is set to 0. The device does not attempt to activate the output until instructed by the microcontroller to do so. After eliminating the cause of the current limit, reactivate the output by setting OSTAT0.OC[3:0] to 1.

Short to either ground or battery causes the output to be latched off and its corresponding OSTAT0.OC[3:0] bit to be set to 0. After removing the short, reactivate the output by setting OSTAT0.OC[3:0] to 1.

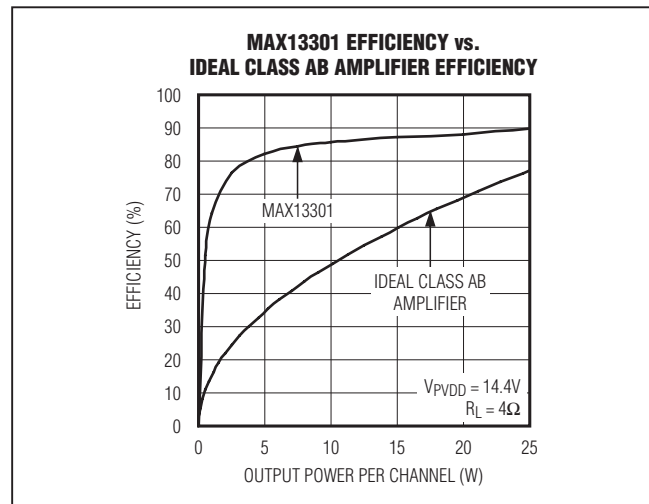

Figure 2. Efficiency vs. Output Power of Class AB Amplifier and the MAX13301

4-Channel, Automotive Class D Audio Amplifier

The device has real-time current limit for shorted outputs, outputs shorted to battery, outputs shorted to ground, and outputs shorted to adjacent channels.

For shorted outputs, the devices enter cycle-by-cycle current limit. In a BTL configuration, current flows diagonally through two of the four FETs at any instant in time. If the current in either of these FETs reaches the current-limit threshold, then both turn off and the other pair of diagonal FETs turns on for a fixed time. This creates distortion, as the music clips. The internal logic of the device counts the cycle-by-cycle current-limit events, and if too many happen in a fixed amount of time, the devices latch off the faulted channel. Current limit is programmable with the I²C. When CTRL3.HCL = 1, the peak current is limited to 8.75A (typ). With CTRL3.HCL = 0, peak current is limited to 7A (typ).

Short-to-battery and short-to-ground take advantage of the diagonal flow of current in a full bridge to detect fault conditions. The load current during normal operation should be equal in the two diagonal FETs that are actively conducting current. When an output is shorted to battery or ground, the current is no longer equal and the degree of mismatch is a measure of the severity of the fault. If the mismatch threshold is exceeded in any channel, that channel is immediately shut down and an overcurrent fault is reported. The level of mismatch is programmable through I²C. When CTRL1.CL_TH = 0, the mismatch threshold is 3.09A with CTRL3.HCL = 0 and 3.86A with CTRL3.HCL = 1. When CTRL1.CL_TH = 1, the mismatch threshold is 1.03A with CTRL3.HCL = 0 and 1.28A with CTRL3.HCL = 1. The lower setting is preferred in that it can detect a misconfigured speaker. For example, the lower setting issues a fault if a 4Ω speaker is incorrectly connected between one of the outputs and ground. At startup, when a large snubber capacitor is present, the higher setting is sometimes required to avoid false trips. When the bridge starts switching, both snubber capacitors must be charged to half the battery. The charging current mimics a short to ground. Following the startup procedure is the best way to avoid issues with overcurrent faults.

Mute/Precharging

The device features a clickless/popless mute mode. When muted, the volume at the speaker is reduced to an inaudible level. To mute the device, configure MUTE_CL1 as a mute input by setting MAP.MCLP (clip output mapping bit) to 0. Then drive the mute input low. Use the mute function during system power-up and power-down to ensure optimum click-and-pop performance.

It is also advisable to set CTRL1.PRE (precharge bit) to 1 after taking the device out of standby mode to pre-charge the input DC-blocking capacitors. This action should be part of any startup routine. Precharging the DC-blocking capacitors enhances click-and-pop performance. Capacitors that are 0.47μF/2μF in series with the inputs take about 1ms to be charged.

Output Configuration

The four FETs forming the full-bridge output of each channel can be programmed into one of four states: high-impedance (default), forced overvoltage, mute, and play through the CTRL2.MD01_[1:0] (channels 0 and 1 output mode) and CTRL2.MD23_[1:0] (channels 2 and 3 output mode) bits. Channels 0 and 1 and channels 2 and 3 always share the same configuration.

In high-impedance mode, all four FETs are turned off. In forced overvoltage state, each half-bridge output is regulated to 1/2 V_{PVDD}. In mute mode, the outputs continue to switch but the volume is kept to an inaudible level. In play mode, the FETs switch normally.

I²C Interface

The device features an I²C, 2-wire serial interface consisting of a serial-data line (SDA) and a serial-clock line (SCL). SDA and SCL facilitate communication between the device and the master at clock rates up to 400kHz. When the device is used on an I²C bus with multiple devices, the V_{DD} supply must stay powered on to ensure proper I²C bus operation. The master, typically a microcontroller, generates SCL and initiates data transfer on the bus. Figure 3 shows the 2-wire interface timing diagram.

A master device communicates to the IC by transmitting the proper address followed by the data word. Each transmit sequence is framed by a START (S) or repeated START (Sr) condition, and a STOP (P) condition. Each word transmitted over the bus is 8 bits long and is always followed by an acknowledge clock pulse.

The SDA line operates as both an input and an open-drain output. A pullup resistor, greater than 500Ω, is required on the SDA bus. The SCL line operates as an input only. A pullup resistor, greater than 500Ω, is required on SCL if there are multiple masters on the bus, or if the master in a single-master system has an open-drain SCL output. Series resistors in line with SDA and SCL are optional. The SCL and SDA inputs suppress noise spikes to ensure proper device operation even on a noisy bus.

4-Channel, Automotive Class D Audio Amplifier

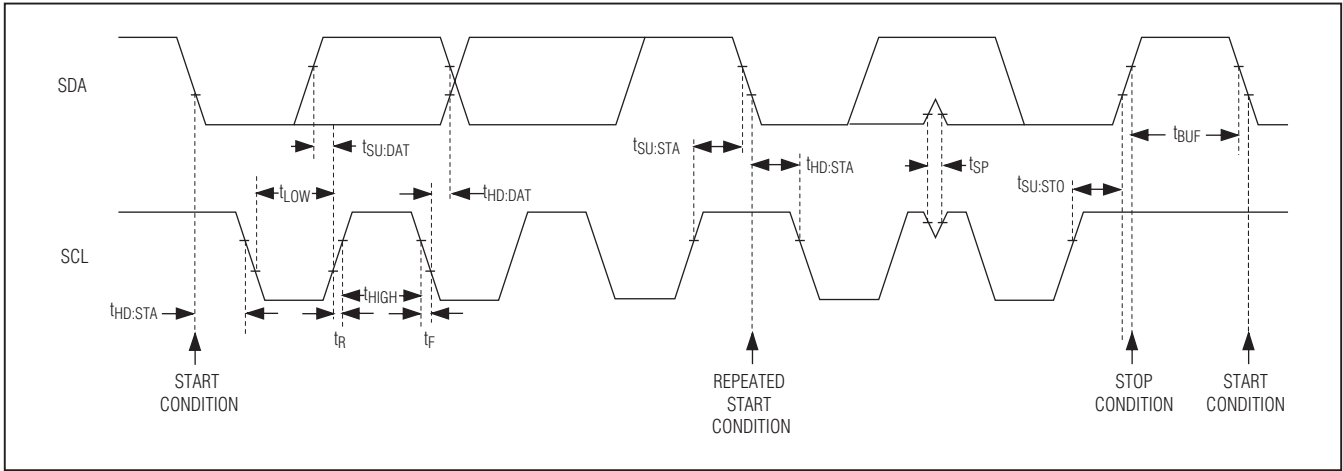

Figure 3. 2-Wire Serial-Interface Timing Diagram

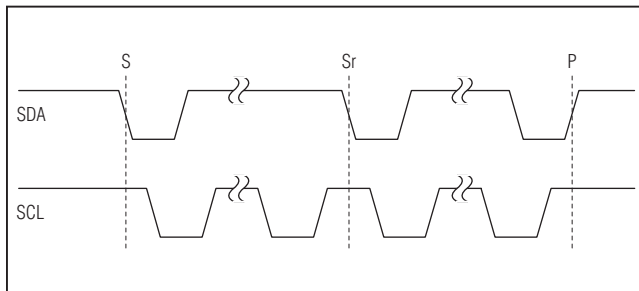

Figure 4. START, STOP, and Repeated START Conditions

Bit Transfer

One data bit is transferred during each SCL cycle. The data on SDA must remain stable during the high period of the SCL pulse. Changes in SDA while SCL is high are control signals (see the *START and STOP Conditions* section). SDA and SCL idle high when the I²C bus is not busy.

STOP and START Conditions

A master device initiates communication by issuing a START condition. A START condition is a high-to-low transition on SDA with SCL high. A STOP condition is a low-to-high transition on SDA while SCL is high (Figure 4). A START condition from the master signals the beginning of a transmission to the device. The master terminates transmission and frees the bus by issuing a STOP condition. The bus remains active if a repeated START condition is generated instead of a STOP condition.

Early STOP Condition

The device recognizes a STOP condition at any point during data transmission, except if the STOP condition occurs in the same high pulse as a START condition.

Slave Address

Each time the device is enabled, the state of the MUTE_CL1 input is latched and determines the device's slave address. Table 2 shows the two possible hardware-defined slave addresses of the devices.

Once the device is enabled, it is programmable to one of four I²C slave addresses through CTRL4.ADDR[1:0] (I²C slave address setting bits), as shown in Table 3. When initially setting the slave address, use the default slave address as discussed in the previous paragraph and shown in Table 2. After setting the slave address, set the CTRL5.ADDR_DEF (I²C slave address definition bit) to 1. For subsequent reads and writes, use the new software-defined address. These slave addresses are unique device IDs.

The address is defined as the 7 most significant bits (MSBs) followed by the R/W bit. Set the R/W bit to 1 to configure the device to read mode. Set the R/W bit to 0 to configure the device to write mode. The address is the first byte of information sent to the device after the START condition.

4-Channel, Automotive Class D Audio Amplifier

Table 2. Default Slave Address

MUTE_CL1	A6	A5	A4	A3	A2	A1	A0	R/W	WRITE	READ
Low	1	1	0	1	1	0	1	X	0xDA	0xDB
High	1	1	0	1	1	0	0	X	0xD8	0xD9

Table 3. I2C Programmable Slave Address

CTRL4. ADDR[1:0]	A6	A5	A4	A3	A2	A1	A0	R/W	WRITE	READ
00	1	1	0	1	1	0	0	X	0xD8	0xD9
01	1	1	0	1	1	1	0	X	0xDC	0xDD
10	1	1	0	1	1	0	1	X	0xDA	0xDB
11	1	1	0	1	1	1	1	X	0xDE	0xDF

Acknowledge

The acknowledge bit (ACK) is a clocked 9th bit that the device uses to handshake receipt each byte of data (Figure 5). The device pulls down SDA during the master-generated 9th clock pulse. The SDA line must remain stable and low during the high period of the acknowledge clock pulse. Monitoring ACK allows for detection of unsuccessful data transfers. An unsuccessful data transfer occurs if a receiving device is busy or if a system fault has occurred. In the event of an unsuccessful data transfer, the bus master can reattempt communication.

Write Data Format

A write to the device includes transmission of a START condition, the slave address with the write bit set to 0, one byte of data to register address, one byte of data to the command register, and a STOP condition. Figure 6 illustrates the proper format for one frame.

Read Data Format

A read from the device includes transmission of a START condition, the slave address with the write bit set to 0, one byte of data to register address, restart condition, the slave address with read bit set to 1, one byte of data to the command register, and a STOP condition. Figure 6 illustrates the proper format for one frame.

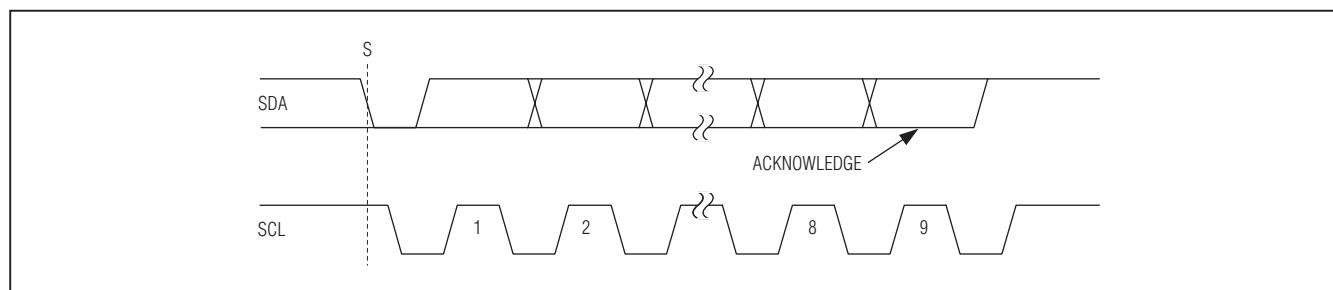

Figure 5. Acknowledge Condition

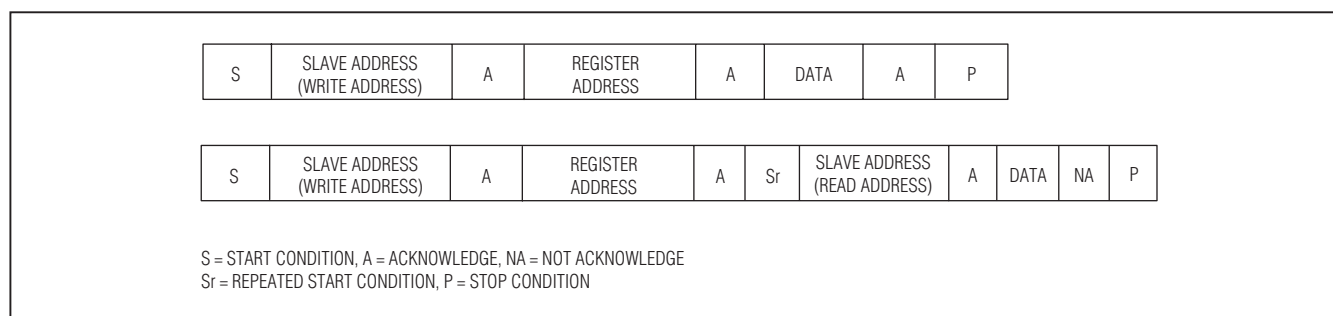

Figure 6. Data Format of I2C Interface Write Mode Read Mode

4-Channel, Automotive Class D Audio Amplifier

Register Map

Table 4. Register Map

REGISTER	BIT 7	BIT 6	BIT 5	BIT 4	BIT 3	BIT 2	BIT 1	BIT 0	ADDRESS	R/W	POWER-ON RESET (POR)
CTRL0	—	—	MDIV3	MDIV2	MDIV1	MDIV0	TW1	TW0	0x00	R/W	0x24
CTRL1	—	CL_TH	CLVL1	CLVL0	—	PRE	CM1	CM0	0x01	R/W	0x00
CTRL2	—	—	STBY	—	MD23_1	MD23_0	MD01_1	MD01_0	0x02	R/W	0x20
CTRL3	TW	RDET	SDET	DIS	—	HCL	—	LDM	0x03	R/W	0x00
CTRL4	—	—	ADDR1	ADDR0	—	—	—	—	0x04	R/W	0xC0
CTRL5	SSEN	RST	SS2	SS1	SS0	PAR1	PAR0	ADDR_DEF	0x05	R/W	0x01
MAP	COMP2	COMP1	COMP0	OTWM	LCTM	MCLP	OTM	FLTM	0x06	R/W	0x40
STAT	—	\overline{OT}	\overline{OTW}	\overline{OV}	\overline{UV}	\overline{OC}	\overline{CPUV}	\overline{CLIP}	0x07	R	—
OSTAT0	$\overline{OC3}$	$\overline{OC2}$	$\overline{OC1}$	$\overline{OC0}$	$\overline{CLIP3}$	$\overline{CLIP2}$	$\overline{CLIP1}$	$\overline{CLIP0}$	0x08	R	—
OSTAT1	$\overline{LDOK3}$	$\overline{LDOK2}$	$\overline{LDOK1}$	$\overline{LDOK0}$	$\overline{LOAD3}$	$\overline{LOAD2}$	$\overline{LOAD1}$	$\overline{LOAD0}$	0x09	R	—
OSTAT2	$\overline{SBAT3}$	$\overline{SBAT2}$	$\overline{SBAT1}$	$\overline{SBAT0}$	$\overline{SGND3}$	$\overline{SGND2}$	$\overline{SGND1}$	$\overline{SGND0}$	0x0A	R	—
OSTAT3	—	—	—	VER	$\overline{VOS3}$	$\overline{VOS2}$	$\overline{VOS1}$	$\overline{VOS0}$	0x0B	R	—

Table 5. Control Register 0

CTRL0								
BIT #	7	6	5	4	3	2	1	0
NAME	—	—	MDIV3	MDIV2	MDIV1	MDIV0	TW1	TW0
POR	0	0	1	0	0	1	0	0

Table 6. Control Register 0 Bit Description

BIT	BIT DESCRIPTION
MDIV[3:0]	<p>Master Clock-Divide Ratio. In master mode, the modulation and charge-pump frequencies are each set to $4.5\text{MHz}/(\text{MDIV}[3:0])$. The device is in standby mode for $\text{MDIV}[3:0] \leq 3$. The valid operating frequencies are 750kHz, 642.9kHz, 562.5kHz, 500kHz, 450kHz, 409.1kHz, 375kHz, 346.2kHz, 321.4kHz, and 300kHz. Switching frequencies below 450kHz compromises noise, as a larger integrator and triangle-wave capacitor trim setting is required.</p> <p>In slave mode, the modulation and charge-pump frequency are always set to $f_{\text{SYNC}}/2$, where f_{SYNC} is the frequency of the clock signal applied to the SYNC input.</p>
TW[1:0]	<p>Thermal Warning Threshold. This threshold determines the temperature at which the status bit $\text{STAT}.\overline{OTW}$ asserts.</p> <p>00 = Junction temperature exceeds 110°C. 01 = Junction temperature exceeds 120°C. 10 = Junction temperature exceeds 130°C. 11 = Junction temperature exceeds 140°C.</p>

4-Channel, Automotive Class D Audio Amplifier

Table 7. Control Register 1

CTRL1								
BIT #	7	6	5	4	3	2	1	0
NAME	—	CL_TH	CLVL1	CLVL0	—	PRE	CM1	CM0
POR	0	0	0	0	0	0	0	0

Table 8. Control Register 1 Bit Description

BIT	BIT DESCRIPTION
CL_TH	Selects the current threshold for the real-time short-to-ground and short-to-battery detection diagnostics. Set this bit to 0 before exiting high-Z mode to prevent false triggering of short-to-ground and short-to-battery faults during startup. Set this bit to 1 after the device has entered mute or play mode. 0 = High threshold 1 = Normal threshold
CLVL[1:0]	Clip Level. The clip level provides an indication of the amount of total harmonic distortion in the output signal. 00 = THD exceeds 10% 10 = THD exceeds 5% 01 = THD exceeds 3% 11 = THD exceeds 1%
PRE	Precharge. Use PRE to precharge the input DC-blocking capacitors. Set this bit to 1 as part of the startup procedure. A 2μF capacitor for IN- and 0.47μF input blocking capacitors require a 1ms precharge to avoid startup pop. 0 = Disable precharging 1 = Enable precharging
CM[1:0]	Clock Mode. Before selecting the operating mode, three-state all outputs. 00 = Master fixed frequency, switching frequency set by the master clock-divide ratio (CTRL0.MDIV[3:0]) bits, SYNC output disabled 01 = Master fixed frequency, switching frequency set by the master clock-divide ratio (CTRL0.MDIV[3:0]) bits, SYNC output enabled 10 = Reserved 11 = Slave fixed frequency, SYNC input enabled

4-Channel, Automotive Class D Audio Amplifier

Table 9. Control Register 2

CTRL2								
BIT #	7	6	5	4	3	2	1	0
NAME	—	—	STBY	—	MD23_1	MD23_0	MD01_1	MD01_0
POR	0	0	1	0	0	0	0	0

Table 10. Control Register 2 Bit Description

BIT	BIT DESCRIPTION
STBY	Standby Mode. Wait 50ms after exiting standby mode to allow the charge pump and reference to stabilize before entering mute or play mode. 0 = Normal mode 1 = Standby mode. The charge pump, preamplifier, and modulator are disabled. Fault monitors and I ² C are still active.
MD23_[1:0]	Channels 2 and 3 Output Mode. Channels 2 and 3 are always in the same configuration. MD23_[1:0] determines the state of outputs 2 and 3. 00 = High-Z 01 = Mute 10 = Forced overvoltage. In this state, both differential outputs are charged to 1/2 VPVDD. 11 = Play
MD01_[1:0]	Channels 0 and 1 Output Mode. Channels 0 and 1 are always in the same mode. MD01_[1:0] determines the state of outputs 0 and 1. 00 = High-Z 01 = Mute 10 = Force overvoltage. In this state, both differential outputs are charged to 1/2 VPVDD. 11 = Play

4-Channel, Automotive Class D Audio Amplifier

Table 11. Control Register 3

CTRL3								
BIT #	7	6	5	4	3	2	1	0
NAME	TW	RDET	SDET	DIS	—	HCL	—	LDM
POR	0	0	0	0	0	0	0	0

Table 12. Control Register 3 Bit Description

BIT	BIT DESCRIPTION
TW	<p>Tweeter-Detect Current Threshold Setting</p> <p>0 = The current threshold at which OSTAT1.LOAD[3:0] (load indicator bit) asserts is set equal to the shorted-load current threshold (see the <i>Electrical Characteristics</i> table). Use this setting when running shorted-load diagnostic.</p> <p>1 = The current threshold at which OSTAT1.LOAD[3:0] asserts is set equal to the tweeter detect current threshold. This threshold is approximately 25% of the default value to facilitate tweeter detection. Use this setting when the running tweeter diagnostic or for detecting the presence of a speaker.</p>
RDET	<p>Open-Load Diagnostic Enable. Upon detecting an open load on any of the outputs, the corresponding OSTAT1.LDOK[3:0] (load OK indicator bit) asserts. Always perform short-to-ground and short-to-battery diagnosis before entering RDET mode. If a short-to-battery is detected, do not enter RDET mode. After performing the short-to-battery test, discharge both outputs by setting CTRL3.DIS to 1 for 200μs, then reset CTRL3.DIS back to 0. Failure to follow this procedure can result in a loud pop at the speaker.</p> <p>Because the results are not latched, read LDOK[3:0] before clearing RDET. Wait a minimum of 200μs before reading these status bits. RDET can only be set after three-stating all four outputs. When performing the open-load diagnostic, set the CTRL3.SDET (short-to-ground/battery enable) bit to 0.</p> <p>0 = Disable open-load diagnostic 1 = Enable open-load diagnostic</p>
SDET	<p>Short-to-Ground/Battery Diagnostic Enable. Upon detecting a short-to-ground or battery on any of the outputs, the corresponding OSTAT2.SBAT[3:0] (short-to-battery) and OSTAT2.SGND[3:0] (short-to-ground) bits assert. Because the results are not latched, read OSTAT2.SBAT[3:0] and OSTAT2.SGND[3:0] before clearing SDET. Wait a minimum of 200μs before reading these status bits. Before setting SDET to 1, three-state all four outputs and set the CTRL3.DIS (discharge output enable) bit to 1 and then reset back to 0. Before performing the short-to-ground/battery diagnostic, set the CTRL3.RDET (open-load diagnostic enable) bit to 0. To test for short-to-ground, set CTRL2.STBY to 0, and to test for short-to-battery, set CTRL2.STBY to 1.</p> <p>0 = Disable short-to-ground/battery diagnostic 1 = Enable short-to-ground/battery diagnostic</p>
DIS	<p>Discharge Output Enable. Set DIS to 1 to discharge all outputs with 15mA current sources. Use DIS to discharge all outputs before performing the short-to-ground/battery diagnostic (SDET) to avoid a loud pop on the speaker. DIS can only be set to 1 after three-stating all four outputs.</p> <p>0 = Output discharge is disabled. 1 = Output discharge is enabled.</p>
HCL	<p>Current-Limit Level. HCL sets the current-limit threshold of the outputs during normal operation.</p> <p>0 = 7A (typ) current limit 1 = 8.75A (typ) current limit</p>
LDM	<p>Line-Driver Mode. Use LDM to set the load resistance threshold required to assert the OSTAT1.LDOK[3:0] (load-okay indicator bit). Any load with a resistance greater than the threshold is interpreted as an open output.</p> <p>0 = Line-driver mode, OSTAT1.LDOK[3:0] = 1 if $R_L > 300\Omega$ 1 = Power amplifier mode, OSTAT1.LDOK[3:0] = 1 if $R_L > 100\Omega$</p>

4-Channel, Automotive Class D Audio Amplifier

Table 13. Control Register 4

CTRL4								
BIT #	7	6	5	4	3	2	1	0
NAME	—	—	ADDR1	ADDR0	—	—	—	—
POR	1	1	0	0	X	X	X	X

Table 14. Control Register 4 Bit Description

BIT	BIT DESCRIPTION
ADDR[1:0]	<p>I²C Slave Address Setting. Use ADDR[1:0] to set the slave address of the device. After setting the slave address, set CTRL5.ADDR_DEF (I²C slave address definition bit) to 1 to make the new address effective.</p> <p>00 = Slave address set to 1101100 R\overline{W}</p> <p>01 = Slave address set to 1101110 R\overline{W}</p> <p>10 = Slave address set to 1101101 R\overline{W}</p> <p>11 = Slave address set to 1101111 R\overline{W}</p>

4-Channel, Automotive Class D Audio Amplifier

Table 15. Control Register 5

CTRL5								
BIT #	7	6	5	4	3	2	1	0
NAME	SSEN	RST	SS2	SS1	SS0	PAR1	PAR0	ADDR_DEF
POR	0	0	0	0	0	0	0	1

Table 16. Control Register 5 Bit Description

BIT	BIT DESCRIPTION
SSEN	Spread-Spectrum Modulation Enable. 0: Spread-spectrum disabled; SSEN = 1 and SS[2:0] > 0: Spread-spectrum enabled
RST	Reset. Setting RST to 1 resets the device. In reset, all register bits are reset to their POR values. RST is automatically cleared back to 0 after device reset. 0 = Not in reset 1 = Reset
SS[2:0]	Spread-Spectrum Modulation Control. Spread-spectrum modulation is enabled when SSEN = 1 and SS[2:0] > 0, once enabled the switching frequency varies from +2% to +7% (see Table 17).
PAR[1:0]	Parallel Mode. The four outputs can be paralleled in one of four ways. To parallel outputs, connect the positive outputs together and connect the negative outputs together. In parallel mode, only the feedback inputs corresponding to the slaved input IN0+ or IN2+ are used. Connect the other feedback inputs to ground. 00 = 4-channel output 01 = 2.1-channel output. Outputs 0 and 1 are paralleled and slaved to input IN0+. Channels 2 and 3 are unaffected. 10 = 2.1-channel output. Outputs 2 and 3 are paralleled and slaved to input IN2+. Channels 0 and 1 are unaffected. 11 = 2-channel output. Outputs 0 and 1 are paralleled and slaved to input IN0+. Outputs 2 and 3 are paralleled and slaved to input IN2+.
ADDR_DEF	I ² C Slave Address Definition. This bit determines whether the I ² C slave address is hardware or software-defined. 0 = Slave address is defined by CTRL4.ADDR[1:0] (I ² C slave address setting bits). 1 = Slave address is set to the default address as defined by the state of the MUTE_CL1 input when the enable input EN is pulled high.

Table 17. Spread-Spectrum Modulation Table

SSEN	SS2	SS1	SS0	SPREAD (%)
0	X	X	X	Disabled
1	0	0	0	0
1	0	0	1	2
1	0	1	0	3
1	0	1	1	4
1	1	0	0	5
1	1	0	1	6
1	1	1	0	7
1	1	1	1	Reserved

4-Channel, Automotive Class D Audio Amplifier

Table 18. Mapping Register

	MAP							
BIT #	7	6	5	4	3	2	1	0
NAME	COMP2	COMP1	COMP0	OTWM	LCTM	MCLP	OTM	FLTM
POR	0	1	0	0	0	0	0	0

Table 19. Mapping Register Bit Description

BIT	BIT DESCRIPTION
COMP[2:0]	<p>Integrator and Triangle-Wave Capacitor Trim. A smaller integrator capacitor pushes noise out of the audio band yielding the lowest noise. If distortion rises at high output powers, lower switching frequencies, or higher PVDD voltages then use a larger capacitor setting. See Table 20 for choosing minimum capacitor settings based on PVDD and the switching frequency. Larger capacitor values can be used.</p> <p>If all 4 channels of the amplifier are used to drive subwoofers, the capacitor settings can be relaxed because a smaller capacitor setting helps to eliminate high-frequency noise (greater than 10kHz). Systems with multiple tweeters benefit the most from proper COMP[2:0] selection. Lower switching frequencies are possible when this high-frequency noise is not a concern as with systems that lack tweeters.</p> <p>000 = 43pF 001 = 37pF 010 = 31pF 011 = 25pF 100 = 18pF 101 = Reserved 110 = Reserved 111 = Reserved</p>
OTWM	<p>Overtemperature Warning Mapping Bit</p> <p>0 = STAT.OTW (overtemperature warning bit) is unmapped to the $\overline{\text{FLT_OT}}$ open-drain output. 1 = STAT.OTW is mapped to $\overline{\text{FLT_OT}}$ when MAP.OTM = 1.</p>
LCTM	<p>Low-Current Threshold Mapping Bit. The current thresholds used in tweeter and shorted load diagnostics are lower than the current limit. When the threshold is exceeded in running either diagnostic, OSTAT1.LOAD[3:0] (load indicator bit) asserts. Hardware indication is also possible by using LCTM to map OSTAT1.LOAD[3:0] to the $\overline{\text{CL0}}$ and $\overline{\text{MUTE_CL1}}$ outputs.</p> <p>0 = OSTAT1.LOAD[3:0] (load indicator bit used for tweeter and shorted load diagnostics) is unmapped to the $\overline{\text{CL0}}$ and $\overline{\text{MUTE_CL1}}$ outputs. 1 = OSTAT1.LOAD[3:0] is mapped to the $\overline{\text{CL0}}$ and $\overline{\text{MUTE_CL1}}$ outputs. Use this setting only when running tweeter or shorted load diagnostic.</p>
MCLP	<p>Clip Output Mapping. MCLP determines which open-drain outputs ($\overline{\text{CL0}}$ and $\overline{\text{MUTE_CL1}}$) are used to indicate clipping on an audio output. $\overline{\text{CL0}}$ is always used as a clip indicator, while $\overline{\text{MUTE_CL1}}$ is configurable as a clip indicator output or as a mute input.</p> <p>0 = $\overline{\text{CL0}}$ provides clip indication for all audio outputs; $\overline{\text{MUTE_CL1}}$ is configured as a mute input. 1 = $\overline{\text{CL0}}$ provides clip indication for audio outputs 0 and 1; $\overline{\text{MUTE_CL1}}$ is configured as a clip indicator output for audio outputs 2 and 3.</p>
OTM	<p>Overtemperature Shutdown Map</p> <p>0 = STAT.OT (overtemperature shutdown bit) is unmapped to the open-drain $\overline{\text{FLT_OT}}$ output. 1 = STAT.OT is mapped to the $\overline{\text{FLT_OT}}$ output.</p>
FLTM	<p>Fault Mapping Bit</p> <p>0 = Faults are unmapped to the open-drain $\overline{\text{FLT_OT}}$ output. 1 = Any fault condition (as indicated by the status bits $\overline{\text{OV}}$, $\overline{\text{UV}}$, $\overline{\text{OC}}$) causes $\overline{\text{FLT_OT}}$ to assert low.</p>

4-Channel, Automotive Class D Audio Amplifier

Table 20. COMP[2:0] Setting Lookup Table

f _{sw} /V _{PVDD}	< 8V	8V to 9.5V	9.5V to 12.65V	12.65V to 15.6V	15.6V to 18.65V	18.65V to 21.1V	> 21.1V
300k	100	100	100	011	011	010	001
320k	100	100	100	011	011	010	010
346k	100	100	100	100	011	010	010
375k	100	100	100	100	011	011	010
409k	100	100	100	100	100	011	011
450k	100	100	100	100	100	011	011
475k	100	100	100	100	100	100	011
500k	100	100	100	100	100	100	011
530k	100	100	100	100	100	100	011
562k	100	100	100	100	100	100	100
600k	100	100	100	100	100	100	100
643k	100	100	100	100	100	100	100
675k	100	100	100	100	100	100	100
700k	100	100	100	100	100	100	100
725k	100	100	100	100	100	100	100
750k	100	100	100	100	100	100	100

Table 21. Status Register

STAT								
BIT #	7	6	5	4	3	2	1	0
NAME	—	\overline{OT}	\overline{OTW}	\overline{OV}	\overline{UV}	\overline{OC}	\overline{CPUV}	\overline{CLIP}

Table 22. Status Register Bit Description

BIT	BIT DESCRIPTION
\overline{OT}	Overtemperature Shutdown. The device goes into thermal shutdown when the junction temperature exceeds +150°C. 0 = Device is in thermal shutdown. 1 = Device is not in thermal shutdown.
\overline{OTW}	Overtemperature Warning. \overline{OTW} asserts when the junction temperature exceeds the thermal warning threshold programmed in CTRL0.TW[1:0]. 0 = Junction temperature is greater than the programmed thermal warning threshold. 1 = Junction temperature is less than the programmed thermal warning threshold.
\overline{OV}	Overvoltage Indicator 0 = V _{PVDD} is greater than the PVDD overvoltage lockout (OVLO) threshold as defined in the <i>Electrical Characteristics</i> table. 1 = V _{PVDD} is less than the OVLO threshold.
\overline{UV}	Undervoltage Indicator 0 = V _{PVDD} is less than the PVDD undervoltage lockout (UVLO) threshold as defined in the <i>Electrical Characteristics</i> table. 1 = V _{PVDD} is greater than the UVLO threshold.

4-Channel, Automotive Class D Audio Amplifier

Table 22. Status Register Bit Description (continued)

BIT	BIT DESCRIPTION
$\overline{\text{OC}}$	General Overcurrent Indicator. $\overline{\text{OC}}$ asserts when there is an overcurrent condition on any of the outputs such as a short-to-ground/battery. To identify which output(s) is experiencing an overcurrent condition, read the $\text{OSTAT0}.\overline{\text{OC}}[3:0]$ (overcurrent indicator bit). 0 = An overcurrent condition exists on one or more of the outputs. 1 = No overcurrent condition.
$\overline{\text{CPUV}}$	Charge-Pump Undervoltage Indicator. $\overline{\text{CPUV}}$ asserts when the voltage on the hold capacitor of the charge pump (CHOLD) falls below 3.87V. It deasserts once the voltage rises above 4.1V. 0 = Undervoltage on CHOLD 1 = Adequate voltage on CHOLD
$\overline{\text{CLIP}}$	General Clip Indicator. $\overline{\text{CLIP}}$ asserts when any of the outputs is clipping. To identify which output(s) is clipping, read the $\text{OSTAT0}.\overline{\text{CLIP}}[3:0]$ (clip indicator) bits. 0 = One or more outputs are clipping. 1 = None of the outputs are clipping.

Table 23. Status Register 0

OSTAT0								
BIT #	7	6	5	4	3	2	1	0
NAME	$\overline{\text{OC}}3$	$\overline{\text{OC}}2$	$\overline{\text{OC}}1$	$\overline{\text{OC}}0$	$\overline{\text{CLIP}}3$	$\overline{\text{CLIP}}2$	$\overline{\text{CLIP}}1$	$\overline{\text{CLIP}}0$

Table 24. Status Register 0 Bit Description

BIT	BIT DESCRIPTION
$\overline{\text{OC}}[3:0]$	Overcurrent Indicator. An overcurrent condition such as a short-to-ground/battery on any of the outputs causes the corresponding $\overline{\text{OC}}[3:0]$ bit to latch to 0. Write a 1 to this bit to clear it. Reset also clears this bit. An overcurrent indicator is available for each output: $\overline{\text{OC}}3$ is for output 3, $\overline{\text{OC}}2$ is for output 2, etc. 0 = There is an overcurrent condition on the output. 1 = There is no overcurrent condition on the output.
$\overline{\text{CLIP}}[3:0]$	Clip Indicator. $\overline{\text{CLIP}}[3:0]$ is a real-time clip indicator for each output. This bit asserts only during the times when an overdriven output is actually clipping. A clip indicator is available for each output: $\overline{\text{CLIP}}3$ is for output 3, $\overline{\text{CLIP}}2$ is for output 2, etc. 0 = Output is clipping. 1 = Output is not clipping.

4-Channel, Automotive Class D Audio Amplifier

Table 25. Status Register 1

OSTAT1								
BIT #	7	6	5	4	3	2	1	0
NAME	LDOK3	LDOK2	LDOK1	LDOK0	LOAD3	LOAD2	LOAD1	LOAD0

Table 26. Status Register 1 Bit Description

BIT	BIT DESCRIPTION
<u>LDOK[3:0]</u>	Load Okay Indicator. When running the open-load diagnostic, <u>LDOK[3:0]</u> = 1 if the load resistance is greater than the resistance threshold set by CTRL3.LDM (line driver mode bit), indicating that the output is properly loaded and not open. A load okay indicator is available for each output: <u>LDOK3</u> is for output 3, <u>LDOK2</u> is for output 2, etc. 0 = Output is loaded. 1 = Output is open.
<u>LOAD[3:0]</u>	Load Indicator. When running shorted load or tweeter diagnostic, <u>LOAD[3:0]</u> asserts if there is a short across the load or if a tweeter is connected. See the <i>Shorted-Load Diagnostic</i> and <i>Tweeter Diagnostic</i> sections for information on the use of <u>LOAD[3:0]</u> in performing load diagnostics. <u>LOAD[3:0]</u> is available for each output: <u>LOAD3</u> is for output 3, <u>LOAD2</u> is for output 2, etc. 0 = Load threshold exceeded. 1 = Load threshold not exceeded.

Table 27. Status Register 2

OSTAT2								
BIT #	7	6	5	4	3	2	1	0
NAME	SBAT3	SBAT2	SBAT1	SBAT0	SGND3	SGND2	SGND1	SGND0

Table 28. Status Register 2 Bit Description

BIT	BIT DESCRIPTION
<u>SBAT[3:0]</u>	Short-to-Battery Indicator. When running a short-to-ground/battery diagnostic, <u>SBAT[3:0]</u> provides indication of any short-to-battery for each output. Use <u>SBAT[3:0]</u> to ensure that there is no short-to-battery before turning on the device. This indicator is available for each output: <u>SBAT3</u> is for output 3, <u>SBAT2</u> is for output 2, etc. 0 = Output is shorted to the battery. 1 = Output is not shorted to the battery.
<u>SGND[3:0]</u>	Short-to-Ground Indicator. When running a short-to-ground/battery diagnostic, <u>SGND[3:0]</u> provides indication of any short-to-ground for each output. Use <u>SGND[3:0]</u> to ensure that there is no short-to-ground before turning on the device. This indicator is available for each output: <u>SGND3</u> is for output 3, <u>SGND2</u> is for output 2, etc. 0 = Output is shorted to ground. 1 = Output is not shorted to ground.

4-Channel, Automotive Class D Audio Amplifier

Table 29. Status Register 3

OSTAT3								
BIT #	7	6	5	4	3	2	1	0
NAME	—	—	—	VER	$\overline{\text{VOS3}}$	$\overline{\text{VOS2}}$	$\overline{\text{VOS1}}$	$\overline{\text{VOS0}}$

Table 30. Status Register 3 Bit Description

BIT	BIT DESCRIPTION
VER	Version Indicator. 0 = Reserved 1 = MAX13301
$\overline{\text{VOS[3:0]}}$	Offset Voltage Indicator. $\overline{\text{VOS[3:0]}}$ indicates whether an offset voltage exists between the differential outputs. Read this bit in play mode after precharge with no signal on the input. This bit is not latched and is not a valid indicator of offset when an input signal is present. An offset voltage indicator is available for each output: $\overline{\text{VOS3}}$ is for output 3, $\overline{\text{VOS2}}$ is for output 2, etc. 0 = The differential offset voltage between OUT_+ and OUT_- exceeds $\pm 1\text{V}$ (typ). 1 = The differential offset voltage between OUT_+ and OUT_- is within $\pm 1\text{V}$ (typ).

Table 31. Fault Conditions

FAULT	MONITORING STATE	REPORTING METHOD	ACTION	LATCHED
Overvoltage	All	I ² C, $\overline{\text{FLT_OT}}$	OUT_- to $1/2 V_{\text{PVDD}}$	No
Undervoltage (PVDD)	Normal, Standby	I ² C, $\overline{\text{FLT_OT}}$	High-Z All	No
Charge-Pump Undervoltage	Normal	I ² C	High-Z All	No
Overtemperature Shutdown	Normal, Standby	I ² C, $\overline{\text{FLT_OT}}$	High-Z All	No
Overtemperature Warning	Normal	I ² C, $\overline{\text{FLT_OT}}$	None	No
Open Load	Normal	I ² C	None	No
Shorted Load	Normal	I ² C	High-Z Channel	Yes
Short-to-Ground/Battery	Normal	I ² C, $\overline{\text{FLT_OT}}$	High-Z Channel	Yes
Clip Output	Normal	I ² C, $\overline{\text{CLO}}$, $\overline{\text{MUTE_CL1}}$	None	No
Overcurrent	Normal	I ² C, $\overline{\text{FLT_OT}}$	High-Z Channel	Yes
DC Offset	Normal, No Music	I ² C	None	No

Fault Detection

The device integrates fault detection and protection circuitry. Table 31 lists all fault events that each device can encounter, the modes in which they are detected, the method with which they are reported, the devices' response to them, and whether they cause the outputs to latch into a high-impedance state.

Load Diagnostics

The device incorporates built-in diagnostics to detect external wire harness faults that can occur during installation or over time. Load diagnostics include short circuit to ground or battery, shorted or open speaker, and open tweeter. Load diagnostics can be run at any time

when the device is in normal mode (i.e., not in standby mode) with the outputs three-stated. The presence of any of these faults is indicated by software through the status registers and by hardware through the $\overline{\text{CLO}}$ and $\overline{\text{MUTE_CL1}}$ open-drain outputs if the status bits have been mapped to the outputs.

Short-to-Ground/Battery Diagnostic

The diagnostic for short-to-battery and ground is done with $\text{CTRL3.SDET} = 1$. None of the results are latched so the OSTAT2 register must be read while running this diagnostic to get a valid status.

If the load is present, a short on either of the differential outputs results in a short on the other output. Therefore,

4-Channel, Automotive Class D Audio Amplifier

the status register only indicates which channel's output is shorted and not which of its differential outputs is shorted. The I²C status register can indicate, for example, that output 1 is shorted to battery, but it cannot differentiate between an OUT1+ and OUT1- short-to-battery.

Before running the short-to-ground/battery diagnostic, perform steps 1 to 3 of the shutdown procedure outlined in the *Startup and Shutdown* section. Before setting CTRL3.SDET to 1, discharge the output by setting CTRL3.DIS to 1 for 200 μ s and reset CTRL3.DIS to 0. Run the short-to-ground/battery diagnostic by setting CTRL3.SDET (short-to-ground/battery diagnostic enable bit) to 1. To test for short-to-ground, set CTRL2.STBY to 0; to test short-to-battery, set CTRL2.STBY to 1. With CTRL2.STBY = 0, 6V is developed at each output. An output voltage > 6V is interpreted as a short-to-battery. An output voltage < 150mV is interpreted as a short to ground. Results of the diagnostic are reported in the OSTAT2.SBAT[3:0] (short-to-battery indicator) and OSTAT2.SGND[3:0] (short-to-ground indicator) bits. Wait a minimum of 200 μ s after setting CTRL3.SDET for valid results. After running the short-to-ground/battery diagnostic, clear the CTRL3.SDET bit to 0.

Because no latch is set, a short-to-ground or battery does not prevent the device from powering up. Therefore, the microcontroller can enable the device into a short although it is discouraged. Should the device be enabled into a short, the real-time overcurrent latches the shorted channel off. The device offers real-time protection for short-to-battery, short-to-ground, and shorted load to prevent damage to the device.

Open-Load Diagnostic

This diagnostic detects an open between OUT₊ and OUT₋ of > 100 Ω or > 300 Ω , depending on the value of CTRL3.LDM (line driver mode bit).

Before running the open-load diagnostic, perform steps 1 to 3 of the shutdown procedure outlined in the *Startup and Shutdown* section. Run the open-load diagnostic test by setting CTRL3.RDET (open-load diagnostic enable bit) to 1, and in the same command, discharge the output capacitors by setting CTRL3.DIS (discharge bit) to 1. During the diagnostic, all low-side FETs of the negative outputs (OUT₋) are turned on, while all other FETs are turned off. The device sources a 2mA current from OUT₊ to OUT₋. If a load is not present, OUT₊ swings high and is interpreted as an open output. Results of the diagnostic are reported in OSTAT1.LDOK[3:0] (load OK indicator bit). Wait

a minimum of 200 μ s for valid results after setting CTRL3.RDET. After running the open-load diagnostic, clear CTRL3.RDET and CTRL3.DIS to 0.

Shorted-Load Diagnostic

This diagnostic detects shorted loads on any of the outputs. To detect shorted loads, the device should be in play mode. Set CTRL3.TW (tweeter-detect current threshold setting bit) to 0 and apply a low-frequency (typically < 20Hz) sinusoidal signal to all the inputs. The device compares the load current to the shorted-load current threshold. If the load current exceeds the threshold, the corresponding OSTAT1.LOAD[3:0] (load indicator bit) is set to 1, indicating that there is a shorted load. The shorted-load current threshold depends on the programmed current limit as set by the CTRL3.HCL. See the High-Current Threshold parameter in the *Electrical Characteristics* table.

Note that the OSTAT1.LOAD[3:0] bits do not latch high upon detecting a short. During zero crossings, the load current does not exceed the threshold and the OSTAT1.LOAD[3:0] bits are cleared to 0. There are two ways to obtain the results of the shorted load diagnostic:

- 1) Continuously read the OSTAT1.LOAD[3:0] bits to determine if any have been set high.
- 2) The open-drain $\overline{\text{CL0}}$ output can also be monitored if MAP.LCTM (low-current threshold map bit) is set to 1 (setting this bit to 1 maps the OSTAT1.LOAD[3:0] bits to the $\overline{\text{CL0}}$ output). Because $\overline{\text{CL0}}$ is the NORed function of the OSTAT1.LOAD[3:0] bits, $\overline{\text{CL0}}$ pulls low if a short exists on any of the outputs.

After running the diagnostic, clear MAP.LCTM to 0 to unmap OSTAT1.LOAD[3:0] to the $\overline{\text{CL0}}$ output. Doing so prevents $\overline{\text{CL0}}$ from being asserted when the shorted-load current threshold is exceeded during play.

Shorted-load diagnostic is done on all outputs. A shorted load is traceable to the output on which it exists by examining the OSTAT1.LOAD[3:0] bits. A shorted load on output 3 causes $\overline{\text{LOAD3}}$ to go low, a shorted load on output 2 causes $\overline{\text{LOAD2}}$ to go low, etc.

Missing Speaker Diagnostic

Using the same technique outlined above, it is possible to detect the absence of a speaker. Set CTRL3.TW to 1 to decrease the shorted-load current threshold by a factor of 4. Apply a low-frequency sine wave (< 20Hz) to the inputs and monitor the load indicator either through the I²C registers or the $\overline{\text{CL0}}$ output. By using the appropriate input signal, a 2 Ω , 4 Ω , or 8 Ω speaker can be detected.

4-Channel, Automotive Class D Audio Amplifier

Tweeter Diagnostic

This diagnostic detects whether a tweeter is properly connected when a passive crossover is used. To detect the presence of a tweeter load, the device should be in play mode. Set CTRL3.TW (tweeter-detect current threshold setting bit) to 1 and apply a 15kHz to 25kHz sinusoidal signal to all the inputs. The devices compare the load current to the tweeter-detect current threshold. If the load current exceeds the threshold, the corresponding OSTAT1.LOAD[3:0] (load indicator bit) is set to 1, indicating that there is a tweeter. The amplitude of the input signal depends on the impedance vs. frequency characteristics of the tweeter. Correct tweeter detection requires that the amplitude be large enough to trip the tweeter-detect current threshold when a tweeter is present. The tweeter-detect current threshold depends on the programmed current limit as set by CTRL3.HCL bit. See the Low-Current Threshold parameter in the *Electrical Characteristics* table.

Note that the OSTAT1.LOAD[3:0] bits do not latch high upon detecting a tweeter. During zero crossings, the load current does not exceed the threshold and the OSTAT1.LOAD[3:0] bits are cleared to 0. There are two ways to obtain the results of the tweeter diagnostic:

- 1) Continuously read the OSTAT1.LOAD[3:0] bits to determine if any have been set high.
- 2) The open-drain $\overline{\text{CL0}}$ output can also be monitored if MAP.LCTM (low-current threshold map bit) is set to 1 (setting this bit to 1 maps OSTAT1.LOAD[3:0] to the $\overline{\text{CL0}}$ output). Because $\overline{\text{CL0}}$ is the NORed function of the OSTAT1.LOAD[3:0] bits, $\overline{\text{CL0}}$ pulls low if a short exists on any of the outputs.

After running the diagnostic, clear CTRL3.TW to 0 to disable tweeter diagnostic and clear MAP.LCTM to 0 to unmap the OSTAT1.LOAD[3:0] bits to the $\overline{\text{CL0}}$ output. Doing so prevents $\overline{\text{CL0}}$ from being asserted when the tweeter-detect current threshold is exceeded during play.

Tweeter diagnostic is done on all outputs. The presence of a tweeter is traceable to any output by examining the OSTAT1.LOAD[3:0] bits. The presence of a tweeter on output 3 causes $\overline{\text{LOAD3}}$ to go high, the presence of a tweeter on output 2 causes $\overline{\text{LOAD2}}$ to go high, etc.

Continuous Diagnostics

The device constantly monitors critical performance and safety parameters such as output offset voltages, output clipping, thermal faults, and undervoltage and overvoltage conditions. The results are reported and continuously updated in the status registers (STAT and OSTAT[3:0]).

Offset Diagnostic

Run the offset diagnostic to determine if there is an offset between the differential outputs. To do so, place the device in play mode and apply no input signals. The results of this diagnostic are reported in OSTAT3.VOS[3:0] (offset voltage indicator bits). OSTAT3.VOS[3:0] indicates whether the offset voltage is less than or greater than the offset voltage threshold. The differential offset threshold is $\pm 1\text{V}$ (typ) for the MAX13301.

Clipping Diagnostic

Use the clipping diagnostic to detect clipping outputs. Program CTRL1.CLVL[1:0] (clip level bit) for a threshold of either 1%, 3%, 5%, or 10% THD+N. Clip indication is provided by OSTAT0.CLIP[3:0] (clip indicator bit). These bits are set to 0 only during the times when an overdriven output is actually clipping. A clipping output indicator is available for each output: $\overline{\text{CLIP3}}$ is for output 3, $\overline{\text{CLIP2}}$ is for output 2, etc. The open-drain outputs, $\overline{\text{CL0}}$ and $\overline{\text{MUTE_CL1}}$, also provide clip indication.

Thermal Warning Diagnostic and Thermal Shutdown

If the junction temperature exceeds the programmed temperature limit, then a temperature warning is set immediately (i.e., STAT.OTW goes low). The device does not act upon a temperature fault to the programmed limit. The temperature fault self clears when the temperature drops below the threshold. The programmed temperature limit is set by CTRL0.TW[1:0] (thermal warning threshold bits) from $+110^{\circ}\text{C}$ to $+140^{\circ}\text{C}$ in 10°C increments. Overtemperature warning by the hardware is also possible by setting both the MAP.OTWM (overtemperature warning map) and MAP.OTM (overtemperature shutdown mask) to 1 to map the STAT.OTW (overtemperature warning) bit to the $\overline{\text{FLT_OT}}$ output.

If the junction temperature exceeds $+150^{\circ}\text{C}$, the device disables all channels and the STAT.OT (overtemperature shutdown) bit asserts low. The digital interface remains active and the contents of the registers are unchanged. When the die temperature drops below $+140^{\circ}\text{C}$, normal operation is restored. Thermal shutdown indication by hardware is also possible by setting MAP.OTM (overtemperature shutdown map bit) to 1 to map the STAT.OT (overtemperature shutdown bit) to the $\overline{\text{FLT_OT}}$ output.

Charge-Pump Undervoltage Diagnostic

The device drives the high-side FETs with the aid of a charge pump. The charge pump charges the hold capacitor CHOLD to 5V at the end of each switching cycle. When the voltage on CHOLD falls below 3.87V, the devices assert STAT.CPUV (charge-pump undervoltage indicator bit) and three-state all outputs. The

4-Channel, Automotive Class D Audio Amplifier

device deasserts the bit only after the voltage on the hold capacitor rises above 4.1V.

Undervoltage Diagnostic

An undervoltage monitor detects low voltages on PVDD (< 6V). During an undervoltage condition, the devices three-state all outputs, set the STAT.UV (undervoltage indicator) bit to 0, and assert the open-drain output FLT_OT.

Overvoltage Diagnostic

The device detects overvoltage and load-dump conditions on PVDD and protect the DMOS outputs from damage. During an overvoltage condition, the devices set STAT.OV (overvoltage indicator bit) to 0, assert the open-drain output FLT_OT, and are latched into standby mode. All differential outputs are regulated to 1/2 VPVDD to minimize the drain-source voltage of the low- and high-side FETs. Once the overvoltage condition is removed, bring the devices out of standby mode by clearing CTRL2.STBY (standby bit). The device can withstand 50V load-dump voltage spikes. Battery charger voltages from 26V to 35V can be withstood for up to 1 hour. Figure 7 illustrates the behavior of the device during a load dump.

Fault Indication

Faults discovered during load diagnostic and continuous diagnostic are indicated through software and hardware. The appropriate status indicator bits (found in the STAT and OSTAT[3:0] registers) assert upon detection of a fault. The host is made aware of the fault through the fault indicator outputs—CL0, MUTE_CL1, and FLT_OT. The host then reads the appropriate status registers to determine which specific fault has occurred.

CL0, MUTE_CL1

CL0 is an open-drain output that indicates clipping on the audio outputs. MUTE_CL1 can be configured as an open-drain output that also indicates clipping on the audio outputs. CL0 also finds use in shorted load and tweeter diagnostics.

FLT_OT

The device asserts the FLT_OT open-drain output upon detecting a fault. A fault is any of the following events: overvoltage, undervoltage, temperature exceeds the programmed overtemperature warning threshold, over-temperature shutdown, and overcurrent.

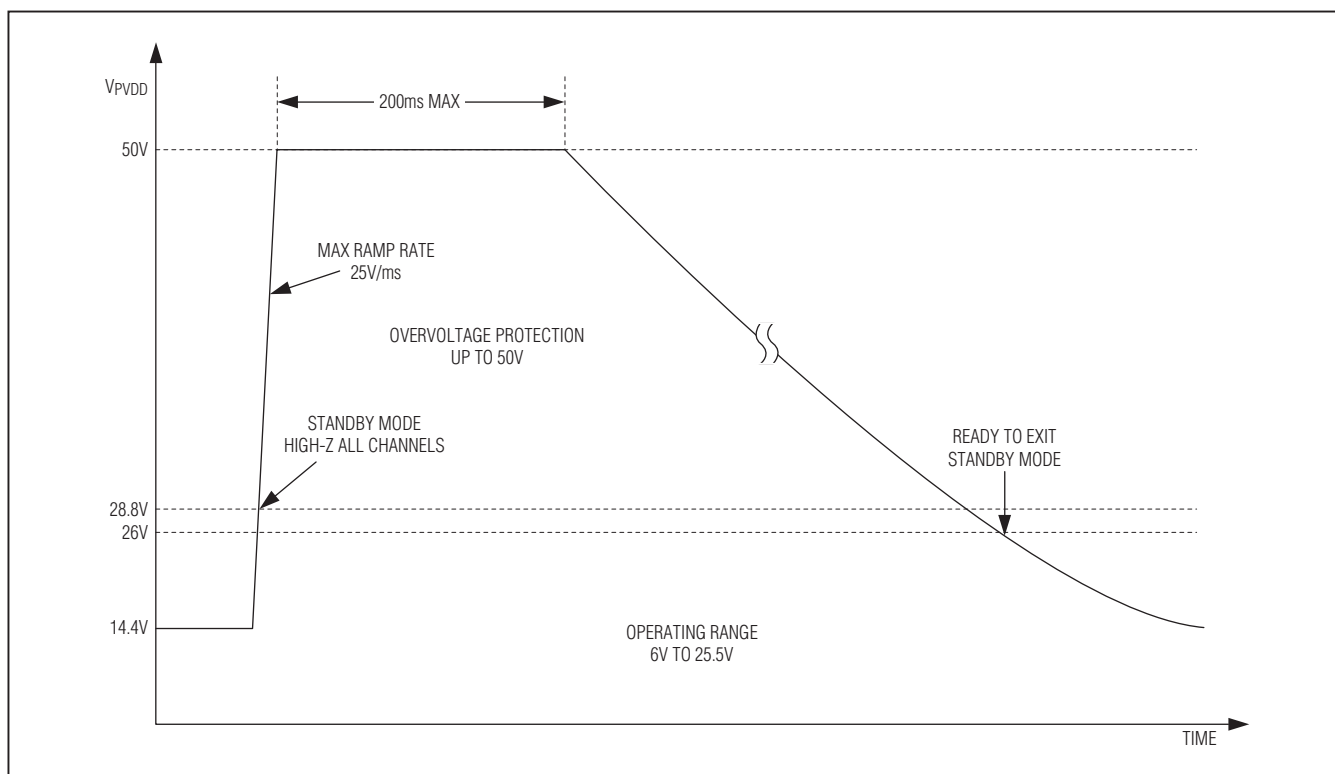

Figure 7. Behavior During Load Dump

4-Channel, Automotive Class D Audio Amplifier

Fault Mapping

The MAP register contains the compensation capacitor, clip output mapping, overtemperature mapping, low-current threshold mapping, and fault mapping bits.

The MAP.COMP[2:0] bits set the internal integrator and triangle-wave capacitor. The value of MAP.MCLP (clip output mapping bit) determines whether MUTE_CL1 is a mute input or clip indicator output.

MAP.OTWM and MAP.OTM map the overtemperature warning bit STAT.OTW and overtemperature shutdown bit STAT.OT to the FLT_OT output. MAP.LCTM enables the low-current threshold mapping when running tweeter and shorted load diagnostics. The fault map is enabled by setting MAP.FLTM to 1, this maps the status register bits STAT.OV, STAT.UV, and STAT.OC to the FLT_OT output.

Applications Information

Startup and Shutdown

Follow these procedures for starting up and shutting down the device. For startup:

- 1) Set the state of MUTE_CL1 to select the I²C slave address (see Table 2).
- 2) Pull the enable input EN high.
- 3) Release MUTE_CL1.
- 4) If more than two I²C addresses are needed, then write to CTRL4.ADDR[1:0] to set the new address. The new address can be set to one of the four addresses shown in Table 3.
- 5) Write CTRL5.ADDR_DEF = 0 to enable the new address, if more than two I²C addresses are needed.
- 6) Set CTRL0, CTRL1.CLVL[1:0], CTRL1.CM[1:0], CTRL3.HCL, CTRL3.LDM, CTRL4, and CTRL5 to the desired values based on application requirements.
- 7) Set CTRL1.CL_TH = 1.
- 8) Set CTRL2.STBY = 0 to enable the device.
- 9) Wait 50ms for the charge pump and reference to stabilize.
- 10) Set CTRL2.MD23_[1:0] = CTRL2.MD01_[1:0] = 01 to mute the outputs. Delay at least 50μs before proceeding.
- 11) Wait 200μs and then clear CTRL1.CL_TH back to 0.

- 12) Set CTRL2.MD23_[1:0] = CTRL2.MD01_[1:0] = 11 to set the outputs to play mode.

For shutdown:

- 1) Set CTRL2.MD23_[1:0] = CTRL2.MD01_[1:0] = 01 to mute the outputs.
- 2) Wait at least 25ms to ensure that there is no click-and-pop noise from a 20Hz signal.
- 3) Set CTRL2.MD23_[1:0] = CTRL2.MD01_[1:0] = 00 to three-state the output.
- 4) Set CTRL2.STBY = 1 to go into standby mode.
- 5) Pull the enable input EN low.

Before running open-load diagnostic or short-to-ground/battery diagnostic, follow steps 1 to 3 of the shutdown procedure to prevent click-and-pop noise.

Class D Operation

Class D amplifiers differ from analog amplifiers such as Class AB in that their output waveform is composed of high-frequency pulses from ground to the supply rail. When viewed with an oscilloscope, the audio signal is not seen; instead, the high-frequency pulses dominate. To evaluate the output of a Class D amplifier requires taking the difference from the positive and negative outputs, then lowpass filtering the difference to recover the amplified audio signal.

Gain

The gain for all 4 channels on the device is fixed at 26dB.

Output Configuration

The device offers flexible output configurations for either 4-channel, 2.1 or high-power, 2-channel sound systems. The configurations are selected using CTRL5.PAR[1:0] (parallel mode bit). In a 2.1 configuration, either outputs 0 and 1 are paralleled together and slaved to input 0, or outputs 2 and 3 are paralleled together and slaved to input 2. In a high-power, 2-channel configuration, outputs 0 and 1 are paralleled and slaved to input 0, while outputs 2 and 3 are paralleled and slaved to input 2. See the *Control Register 5 Bit Description* table (Table 16) for more information about programming the desired output configuration.

Feedback

Connect the speaker inputs to the feedback inputs through 150Ω ±1% resistors as shown in the *Typical Operating Circuit*. Integrated feedback from the LC filter's output improves the THD+N by reducing distortion.

4-Channel, Automotive Class D Audio Amplifier

External Filters

The Class D amplifiers work with external filters. The filter requirement is due to the unshielded wiring harness. This is common for longer speaker lead lengths, and to gain increased margin to EMC limits. See Figure 8 for the correct connections of these components.

The component selection is based on the load impedance of the speaker. Table 32 lists suggested values for a variety of load impedances. Inductors L1 and L2 and capacitor C2 form the primary output filter. In addition to these primary filter components, other components in the filter improve its functionality. RC networks R1-C4 and R2-C5 form Zobel networks at the output. A Zobel corrects the output loading to compensate for the rising impedance of the loudspeaker. Without a Zobel, the filter has a peak in its response near the cutoff frequency. Capacitors C1 and C3 provide additional high-frequency bypass to reduce radiated emissions.

Power Supplies

The devices use different supplies for each portion of the device, allowing for the optimum combination of headroom, power dissipation, and noise immunity. The

speaker amplifiers are powered from PVDD and can range from 6V to 25.5V. The remainder of the device is powered by VDD (analog and digital blocks) and VDD5 (gate drivers and charge-pump circuit). Power supplies are independent of each other so sequencing is not necessary. Power can be supplied by separate sources or derived from a single higher source using a linear regulator to reduce the voltage, as shown in Figure 9.

Component Selection

Input Filter

The device has four positive inputs and one common negative input. The input resistance of each positive input is 20kΩ, while the input resistance of the negative input is 5kΩ. An input capacitor, C_{IN}, in conjunction with the input resistance forms a highpass filter that removes the DC bias from an incoming signal. The DC-blocking capacitor allows the amplifier to automatically bias the signal to an optimum DC level. Assuming zero-source impedance, the -3dB point of the highpass filter is given by:

$$f_0 = 1/2\pi R_{IN} C_{IN}$$

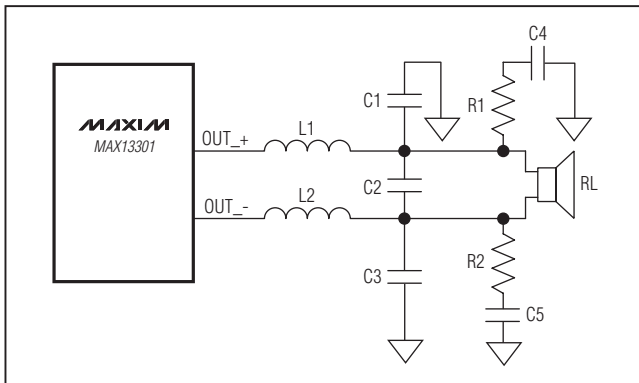

Figure 8. Output Filter

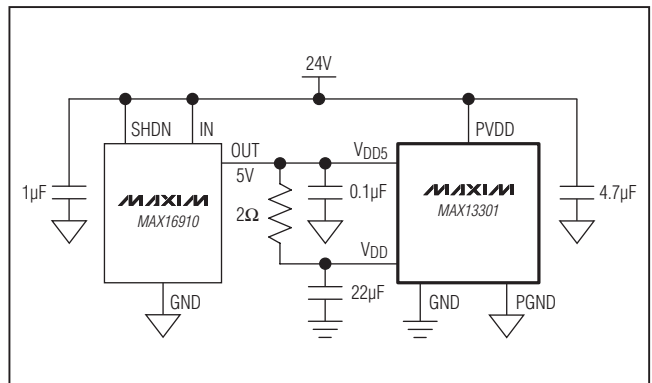

Figure 9. Using a Linear Regulator to Produce 5V from a 24V Power Supply

Table 32. Suggested Values for LC Filters

R _L (Ω)	L1, L2 (µH)	C1, C3 (µF)	C2 (µF)	C4, C5 (nF)	R1, R2 (Ω)
8	10	0.15	0.47	220	10
4	10	0.15	0.47	220	10
2*	10	0.15	0.68	220	10
1*	10	0.15	1	220	10

*Parallel channel operation: at 14.4V (for R_L = 1Ω), at 24V (for R_L = 2Ω).

4-Channel, Automotive Class D Audio Amplifier

Charge-Pump Capacitor Selection

Use capacitors with an ESR less than 100mΩ for optimum performance. Low-ESR ceramic capacitors minimize the output resistance of the charge pump. For best performance over the extended temperature range, select capacitors with an X7R dielectric. The typical value is 1μF.

Flying Capacitor (C_{FLY})

The value of the flying capacitor (C_{FLY}) affects the load regulation and output resistance of the charge pump. A C_{FLY} value that is too small degrades the device's ability to provide sufficient current drive. Increasing the value of C_{FLY} improves load regulation and reduces the charge-pump output resistance to an extent. Use a 50V, 1μF ceramic capacitor for C_{FLY}.

Supply Bypassing, Layout, and Grounding

Proper layout and grounding are essential for optimum performance. Use large traces for the power-supply inputs and amplifier outputs to minimize losses due to parasitic trace resistance. Large traces also aid in moving heat away from the package. Proper grounding improves audio performance, minimizes crosstalk between channels, and prevents any switching noise from coupling into the audio signal. Connect PGND and GND together at a single point on the PCB. Route all traces that carry switching transients away from GND and the traces/components in the audio signal path.

Bypass V_{DD} to GND with a 10μF ceramic capacitor and V_{DD5} to PGND with a 0.1μF ceramic capacitor. Each PVDD is paired with two PGNDs for local supply bypassing. Bypass each PVDD-PGND pair with 0.1μF and 4.7μF ceramic capacitors. Table 35 shows the four PVDD-PGND pairs.

Place an additional 1000μF low-ESR electrolytic capacitor from pins 1 and 48 to PGND and from pins 24 and 25 to PGND.

Use large, low-resistance output traces. Current drawn from the outputs increases as load impedance decreases. High output trace resistance decreases the power delivered to the load. Large output, supply, and PGND traces allow more heat to move from the device to the air, decreasing the thermal impedance of the circuit.

Table 33. PVDD and PGND Pairs

PVDD PIN NUMBER	PGND PIN NUMBER
1	9 and 10
48	39 and 40
24	11 and 12
25	37 and 38

The feedback connections are sensitive to inductor magnetic field interference, so route these traces away from the inductors and noisy traces connected to OUT₋ and the charge pump.

Refer to the MAX13301 Evaluation Kit for a PCB layout example.

Thermal Information

The device requires external heatsinking for applications that dissipate more than 1333.3mW. The top side exposed pad is the primary heat conduction path on the device. The thermal resistance of the heatsink is calculated from the following equation:

$$\theta_{HS} \leq \left(\frac{T_J - T_A}{P_{DISS}} \right) - \theta_{JC} - \theta_{CH}$$

where:

T_J = +150°C

T_A = Ambient Operating Temperature

θ_{JC} = 1°C/W

θ_{CH} = Thermal resistance of the thermal interface used between the top side exposed pad and the heatsink

P_{DISS} = Estimated power dissipation of the device

The estimated power dissipation can be calculated from the following equation based on the desired continuous output power, P_{OUT}, of the application, the typical efficiency, η, and the number of output channels used, N.

$$P_{DISS} \leq \left(\frac{1}{\eta} - 1 \right) \times N \times P_{OUT}$$

4-Channel, Automotive Class D Audio Amplifier

Typical Operating Circuit

MAX13301

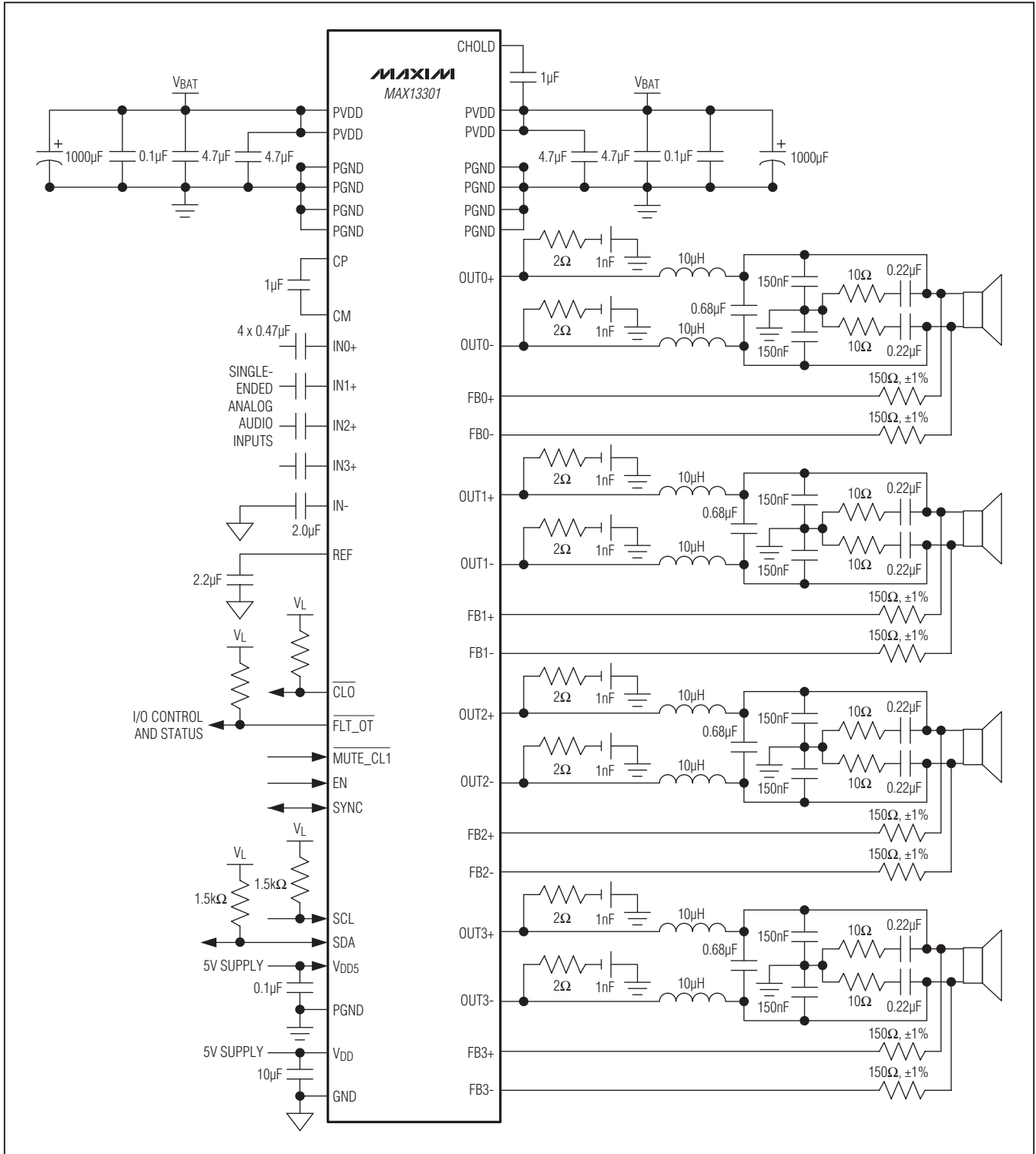

4-Channel, Automotive Class D Audio Amplifier

Chip Information

PROCESS: BiCMOS

Package Information

For the latest package outline information and land patterns, go to www.maxim-ic.com/packages. Note that a "+", "#", or "-" in the package code indicates RoHS status only. Package drawings may show a different suffix character, but the drawing pertains to the package regardless of RoHS status.

PACKAGE TYPE	PACKAGE CODE	OUTLINE NO.	LAND PATTERN NO.
48 TSSOP-EPR	U48ER+1	21-0444	90-0273

4-Channel, Automotive Class D Audio Amplifier

Revision History

REVISION NUMBER	REVISION DATE	DESCRIPTION	PAGES CHANGED
0	6/11	Initial release	—

MAX13301

Maxim cannot assume responsibility for use of any circuitry other than circuitry entirely embodied in a Maxim product. No circuit patent licenses are implied. Maxim reserves the right to change the circuitry and specifications without notice at any time.

Maxim Integrated Products, 120 San Gabriel Drive, Sunnyvale, CA 94086 408-737-7600 _____ **37**

Mouser Electronics

Authorized Distributor

Click to View Pricing, Inventory, Delivery & Lifecycle Information:

[Analog Devices Inc.:](#)

[MAX13301EVKIT+](#)