

DESCRIPTION

Demonstration circuit 923 features the LT[®]3475 dual step-down 1.5A LED driver in a 16-lead TSSOP thermally enhanced package. The demonstration circuit is designed to drive two 1.5A LEDs on separate channels (one on each channel) from a wide input voltage range. The high switching frequency scheme permits the use of a small inductor and ceramic capacitors to save space and cost. The current mode PWM control scheme provides fast transient response and cycle-by-cycle current limiting. Frequency foldback and thermal shutdown provide additional protection. DC923A is specifically designed for high power LED applications such as automotive and avionic lighting, architectural detail lighting and display backlighting. The LT3475 has a

few LED-dimming circuit options. See the datasheet for more detailed information on LED brightness and dimming control using both the PWM pin function and the V_{ADJ} pin function. The PWM terminals can be used to dim the LEDs with the addition of PWM MOSFETS and the resistor-short connections from LED- to GND removed.

NOTE: The input voltage is limited to 4-30V during startup. During normal (non-startup) operation, the input voltage can be as high as 36V.

Design files for this circuit board are available. Call the LTC factory.

LT is a registered trademark of Linear Technology Corporation

QUICK START PROCEDURE

DC923A is easily set up for evaluating the LT3475 dual step-down 1.5A LED driver circuit. Follow the test procedure outlined below and see Figure 2.

1. Connect a bench supply with power OFF to the V_{IN} and GND terminals.
2. Connect a single white 1.5A LED to the LED1+ and LED1- terminals.
3. Connect a single white 1.5A LED to the LED2+ and LED2- terminals.
4. Turn on the input power supply and set the voltage above 6V and below 30V.
5. Observe the LEDs working properly at 1.5A without looking straight at the LEDs. The extreme brightness may be harmful to the eye.

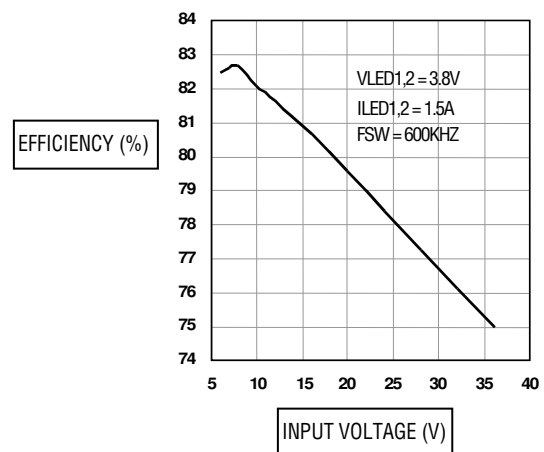

Figure 1. DC923A Efficiency

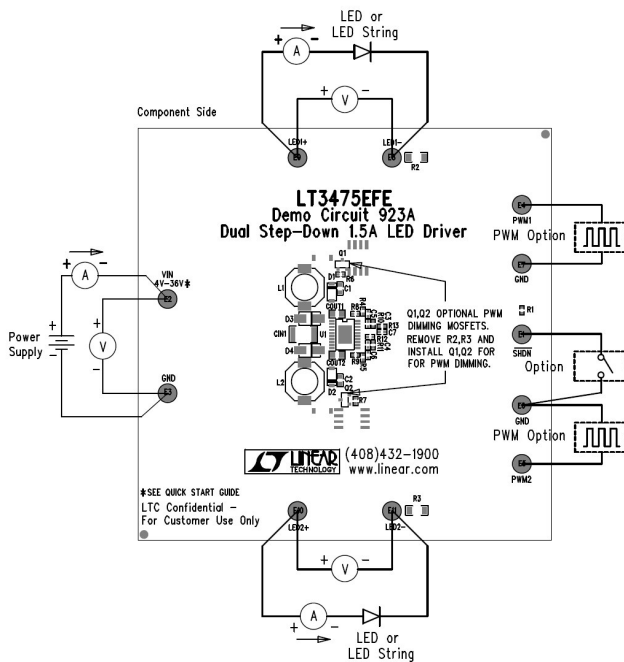

Figure 2. Proper Measurement Equipment Setup

INPUT VOLTAGE RANGE

The operating input voltage range for the LT3475 IC is 4V to 36V with an absolute maximum rating of 40V. Under some conditions, it is not recommended to run the IC up to 36V non-transient DC voltage. Please see the datasheet for input voltage range calculations based on switching frequency, LED output voltage, and compensation network topology during startup. As assembled, the DC923A should not be started up above 30V DC input without first assembling the C-R-C compensation network shown in Figure 3 or using a bigger inductor with up to 3.2A capability in order to maintain control of the switch current.

PWM DIMMING

DC923A is assembled to show a combination of the most basic operation of the IC and the small solution size. The optional PWM dimming MOSFETs (Q1, Q2) are not stuffed on DC923A, but there are two SOT23 spaces designated for these to be added to the board. The LED-to GND resistor-short connections (R2, R3) must be removed from the board to enable PWM dimming when

the PWM dimming MOSFETs are stuffed with their gate pull-down resistors (R6, R7).

For best results, the C-R-C compensation network shown in Figure 3 should be stuffed for each channel when PWM dimming is used. The C-R-C network provides the most optimal LED current transient waveform coming out of PWM dimming off-time. The C-R-C network also helps maintain switch current control during startup with input voltages above 30V.

EXTENDED PWM DIMMING

The PWM dimming range can be extended by adding the components Q3, R13, and C7 to the circuit as shown in Figure 4. Q3 is located on the back of the PCB near the PWM terminal. The datasheet describes the calculation of maximum PWM dimming range with and without the extended dimming range components. When these components are added to the circuit, the PWM1 signal is directly connected to the extended dimming range components. If both channel 1 and channel 2 are being used in PWM dimming mode and the extended dimming range circuit is used, the PWM2 signal must be synchronized with the PWM1 signal. The rising edges must occur at the same time although their duty cycles may vary. Failure to do this may result in significant jitter on the second channel or limited PWM dimming range.

LED STRINGS

DC923A is assembled with optimized components for driving a single white LED at 1.5A on each of its two channels. The LEDs are not assembled on the PCB and should be attached to the LED terminals as shown in Figure 2. If the LEDs are not attached, the DC923A will protect itself and survive an open LED condition.

If more than one LED is attached in series to either output, the inductor size, switching frequency, and/or input voltage range may need to be adjusted for proper operation. Consult the datasheet for proper sizing of the inductor for given input and output voltage conditions. The maximum LED output voltage is 13.5V as defined by the clamp voltage in the datasheet. This limits the number of LEDs in series on the output.

QUICK START GUIDE FOR DEMONSTRATION CIRCUIT 923

DUAL STEP-DOWN 1.5A LED DRIVER

If a single LED such as a red or amber LED with forward voltage below 2.7V is attached to the output, the boost circuit must be altered to supply a boost voltage above 3V from either the input, the other output channel, or from a separate supply. There is a space on each channel on DC923A to accommodate an alternate boost supply or boost diode as shown in Figure 5. If the alternate boost supply is not used in this case, the internal power switch will not run in low V_{CE} saturation and the part may heat up and run inefficiently.

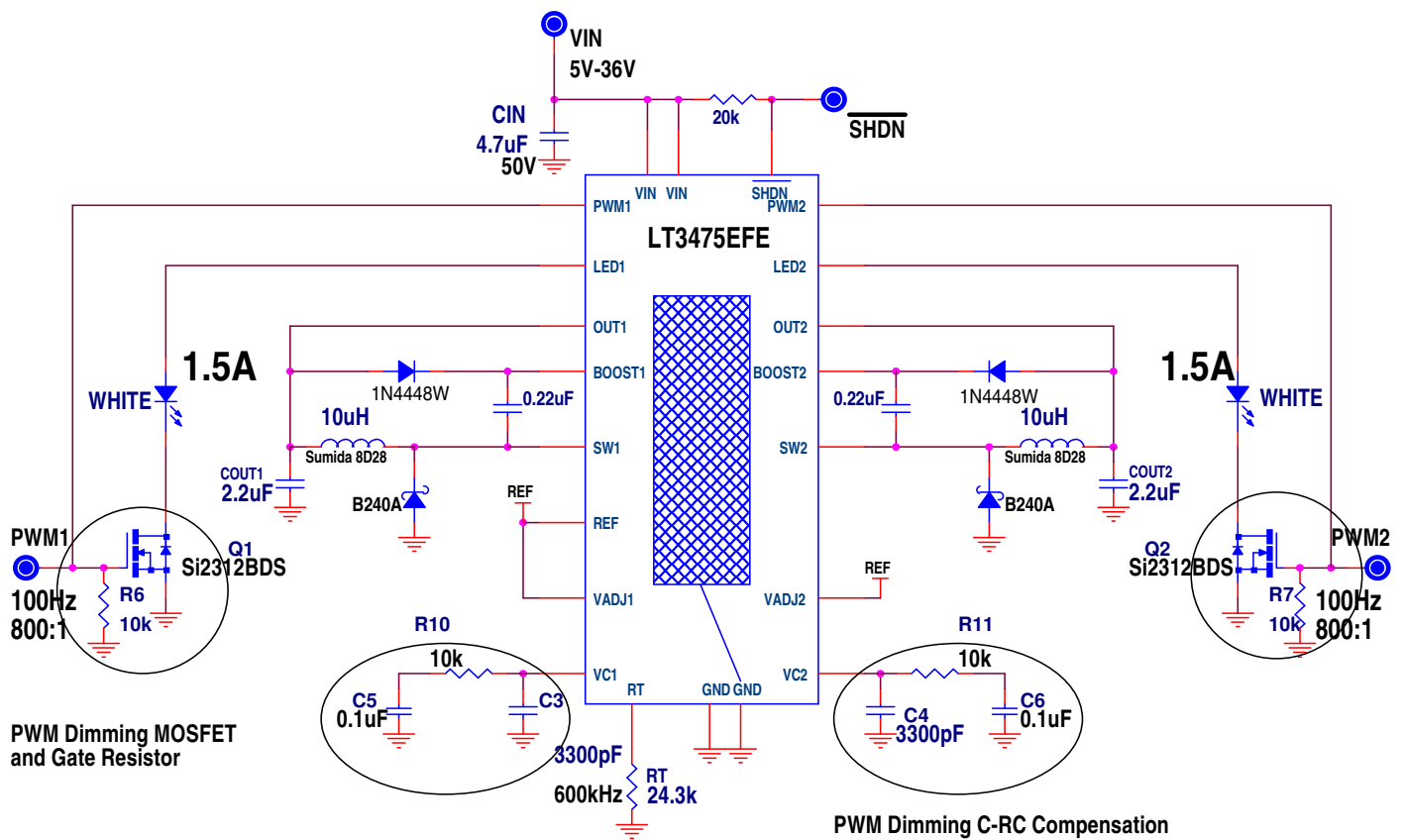

Figure 3. PWM Dimming MOSFETs, Gate Pull-down Resistors, and Optimal CRC Compensation

QUICK START GUIDE FOR DEMONSTRATION CIRCUIT 923

DUAL STEP-DOWN 1.5A LED DRIVER

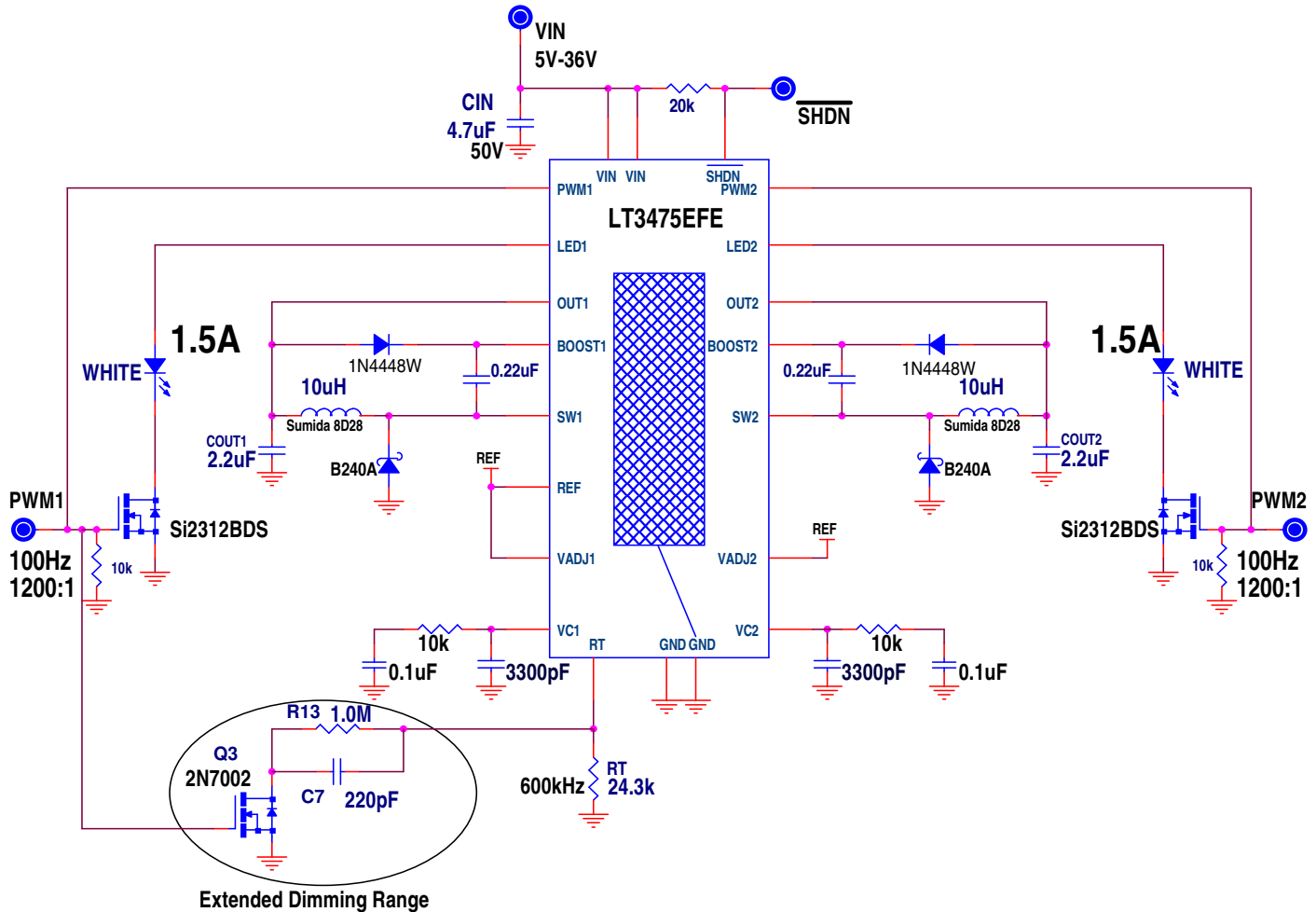

Figure 4. Extended Dimming Range Components Q3, R13, and C7

QUICK START GUIDE FOR DEMONSTRATION CIRCUIT 923

DUAL STEP-DOWN 1.5A LED DRIVER

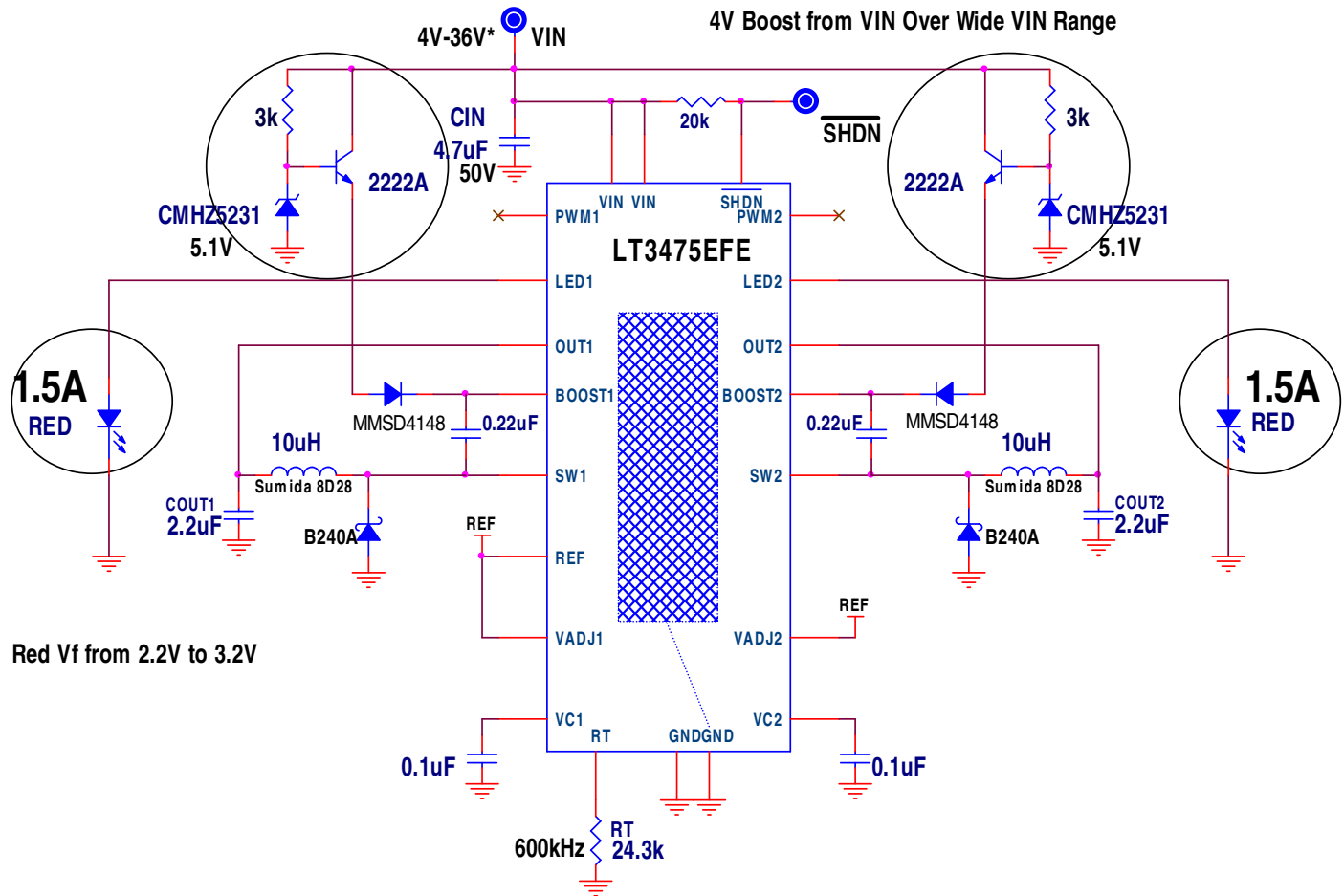

Figure 5. Single Red LED Driver With Alternate Boost Supply From VIN

QUICK START GUIDE FOR DEMONSTRATION CIRCUIT 923

DUAL STEP-DOWN 1.5A LED DRIVER

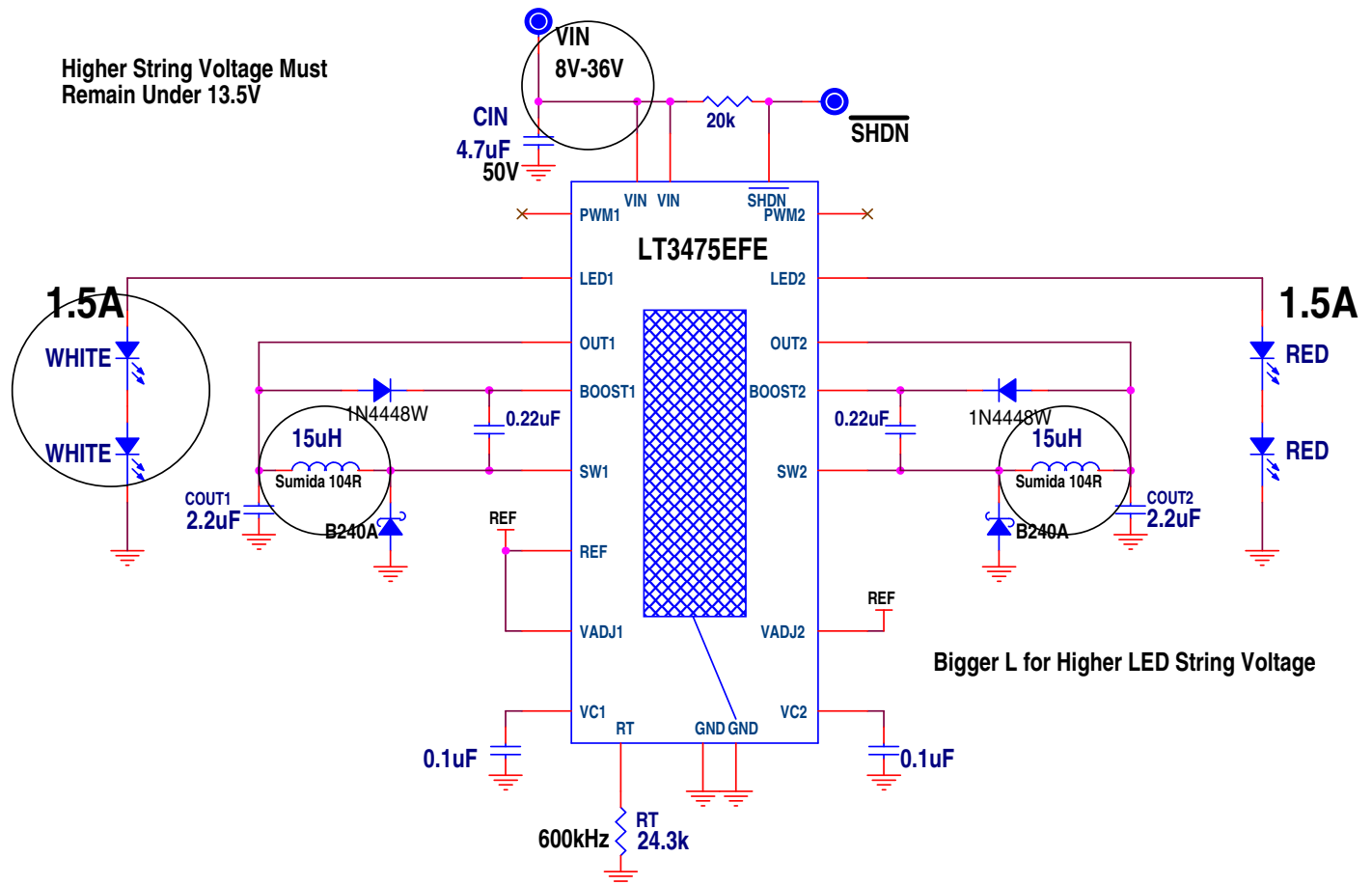
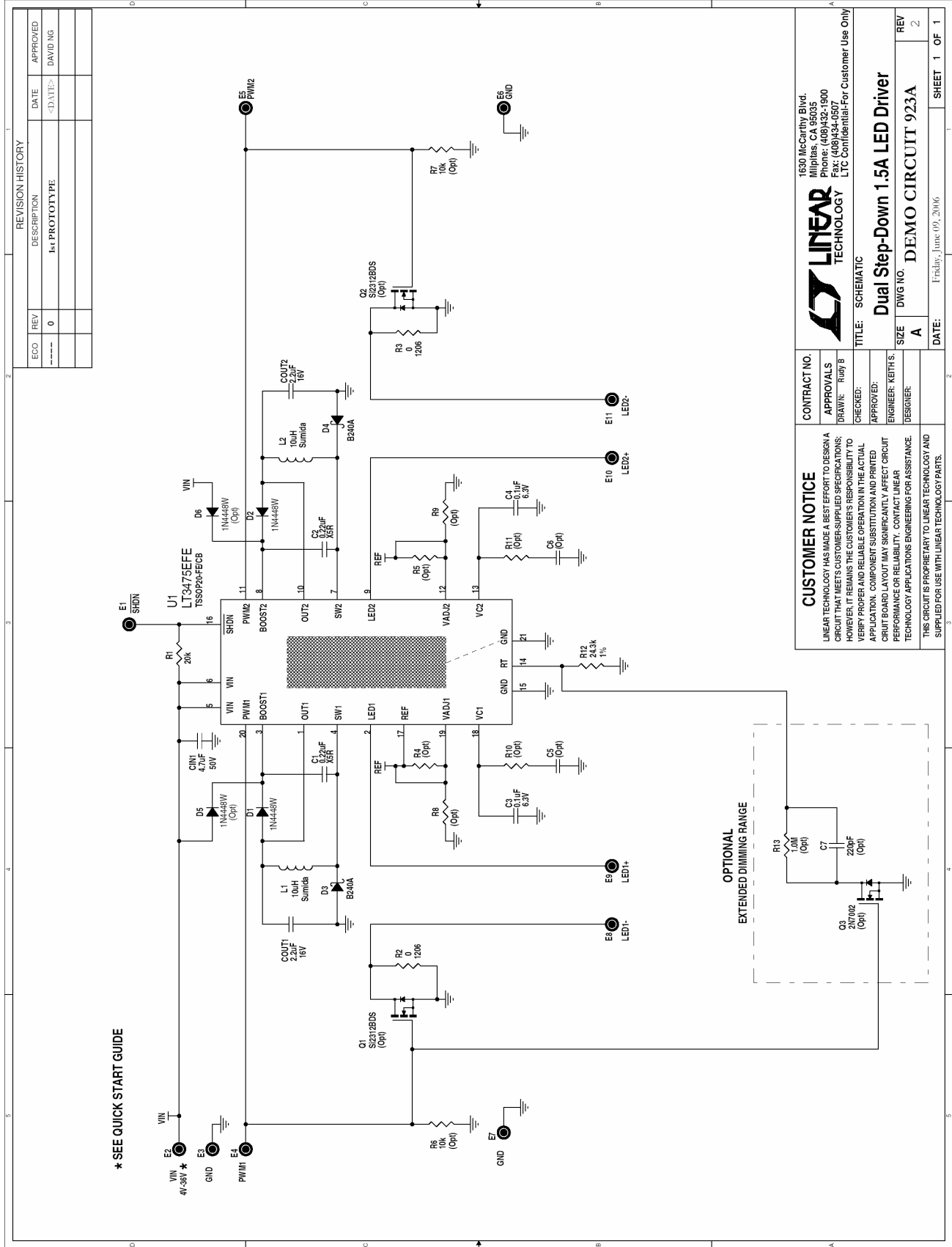

Figure 6. LED strings up to 13.5V require larger inductors to avoid subharmonic oscillations at high duty cycles.

QUICK START GUIDE FOR DEMONSTRATION CIRCUIT 923

DUAL STEP-DOWN 1.5A LED DRIVER



REVISION HISTORY				
ECO	REV	DESCRIPTION	DATE	APPROVED
---	0	1st PROTOTYPE	<DATE>	DAVID NG

		1630 McCarthy Blvd. Milpitas, CA 95035 Phone: (408)332-1900 Fax: (408)334-0507 LTC Confidential-For Customer Use Only	
TITLE: SCHEMATIC			
Dual Step-Down 1.5A LED Driver			
SIZE	DWG NO.	REV	DATE
A	DEMO CIRCUIT 923A	2	Friday, June 09, 2016
SHEET 1 OF 1			

CONTRACT NO.	APPROVALS	CHECKED:	APPROVED:	DESIGNER:
	DRAWN: RUDY B			
LINEAR TECHNOLOGY HAS MADE A BEST EFFORT TO DESIGN A CIRCUIT THAT MEETS CUSTOMER-SUPPLIED SPECIFICATIONS; HOWEVER, IT REMAINS THE CUSTOMER'S RESPONSIBILITY TO VERIFY PROPER AND RELIABLE OPERATION IN THE ACTUAL APPLICATION. COMPONENT SUBSTITUTION AND PRINTED CIRCUIT BOARD LAYOUT MAY SIGNIFICANTLY AFFECT CIRCUIT PERFORMANCE OR RELIABILITY. CONTACT LINEAR TECHNOLOGY APPLICATIONS ENGINEERING FOR ASSISTANCE.				
THIS CIRCUIT IS PROPRIETARY TO LINEAR TECHNOLOGY AND SUPPLIED FOR USE WITH LINEAR TECHNOLOGY PARTS.				

Mouser Electronics

Authorized Distributor

Click to View Pricing, Inventory, Delivery & Lifecycle Information:

[Analog Devices Inc.:](#)

[DC923A](#)