

DESCRIPTION

Demonstration circuit 630 is a g_m amplifier circuit using the LT[®]3469ETS8 and can drive an output up to 34V at 25mA from 5V or 12V supply. An internal Boost converter of the LT3469 generates a supply voltage up to 36V for the g_m amplifier. This regulator switches at 1.5MHz, allowing the use of a tiny external inductor and capacitor. The 36V output capability of the switching regulator along with the high

supply voltage of the amplifier combine to allow the wide output voltage range needed to drive a piezoceramic microactuator.

Design files for this circuit board are available. Call the LTC factory.

LT is a trademark of Linear Technology Corporation

QUICK START PROCEDURE

Demonstration circuit 630 is easy to set up to evaluate the performance of the LT3469ETS8. Refer to Figure 1 for proper measurement equipment setup and follow the procedure below:

NOTE: When measuring the input or output voltage ripple, care must be taken to avoid a long ground lead on the oscilloscope probe. Measure the input or output voltage ripple by touching the probe tip directly across the V_{IN} or V_{OUT} and GND terminals. See Figure 2 for proper scope probe technique.

1. With power off, connect the input power source V_{IN} to the VIN and GND terminals, connect V_{input} to INPUT+ and GND terminals.
2. Apply $V_{IN} = 4.75V$, $V_{input} = 1V$, and $I_{out} = 0mA$ (no load). Check the boost regulator output $V_{CC} = 34.8V \pm 5\%$, and input current I_{in} within the range of 21mA to 35mA.
3. Apply $V_{IN} = 4.75V$, $V_{input} = 1V$, and $I_{out} = 2mA$ (2mA load at V_{OUT}). Check the boost regulator output $V_{CC} = 34.6V \pm 5\%$,

and the input current I_{in} within the range of 34mA to 50mA.

4. Apply $V_{IN} = 16V$, $V_{input} = 1V$, and $I_{out} = 0A$ (no load). Verify the boost regulator output $V_{CC} = 35.2 \pm 5\%$.
5. Apply $V_{IN} = 5V$, $V_{input} = 0.1V$, check the amplifier output $V_{OUT} =$ within the range of 0.87V to 1.12V.
6. Apply $V_{IN} = 5V$, $V_{input} = 3V$, check the amplifier output $V_{OUT} = 33V \pm 2\%$,
7. Apply $V_{IN} = 5V$ and pulsed square wave input that swings from 0.1V to 2.8V and has period of 300 μs to V_{input} , and apply 27nF capacitor load to the output. Verify V_{OUT} and I_{out} as shown in Figure 3.

QUICK START GUIDE FOR DEMONSTRATION CIRCUIT 630 PIEZOCERAMIC MICROACTUATOR DRIVER WITH BOOST REGULATOR

Linear Tech. Corp.
Demo Circuit 630 RevA

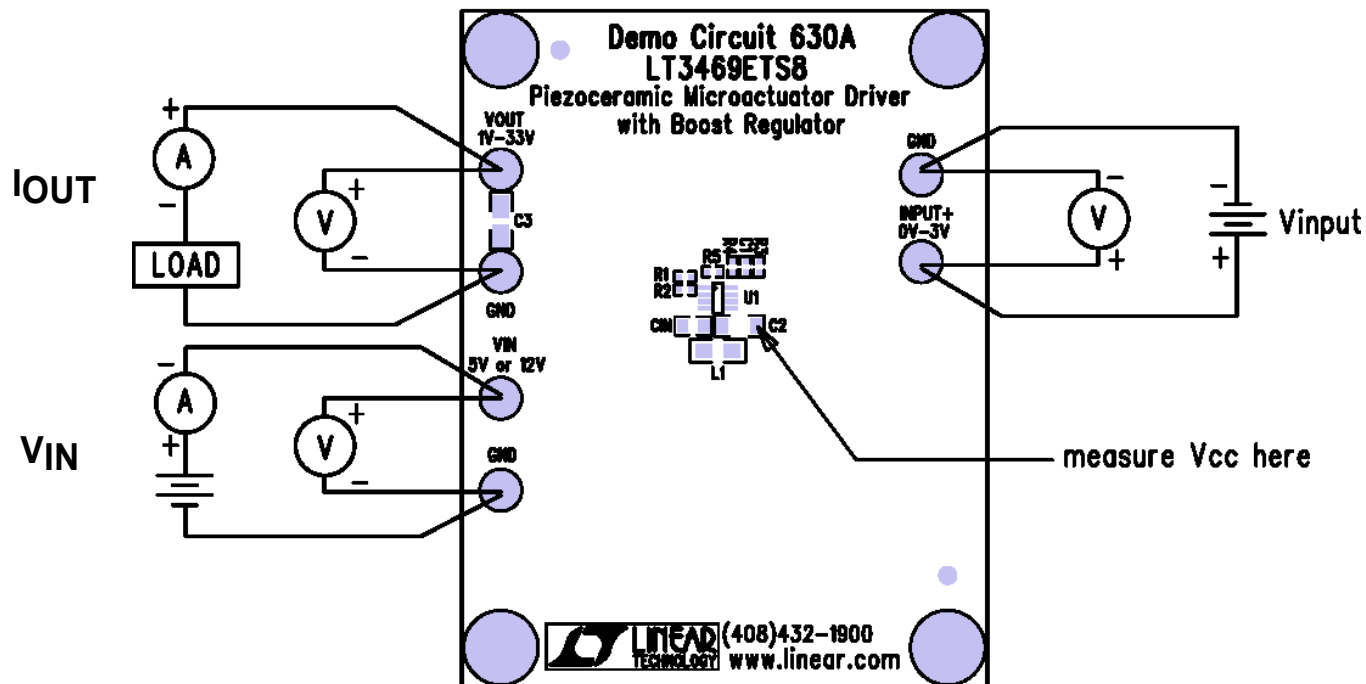

Figure 1. Proper Measurement Equipment Setup

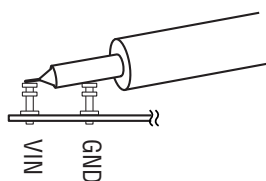

Figure 2. Measuring Input or Output Ripple

QUICK START GUIDE FOR DEMONSTRATION CIRCUIT 630 PIEZOCERAMIC MICROACTUATOR DRIVER WITH BOOST REGULATOR

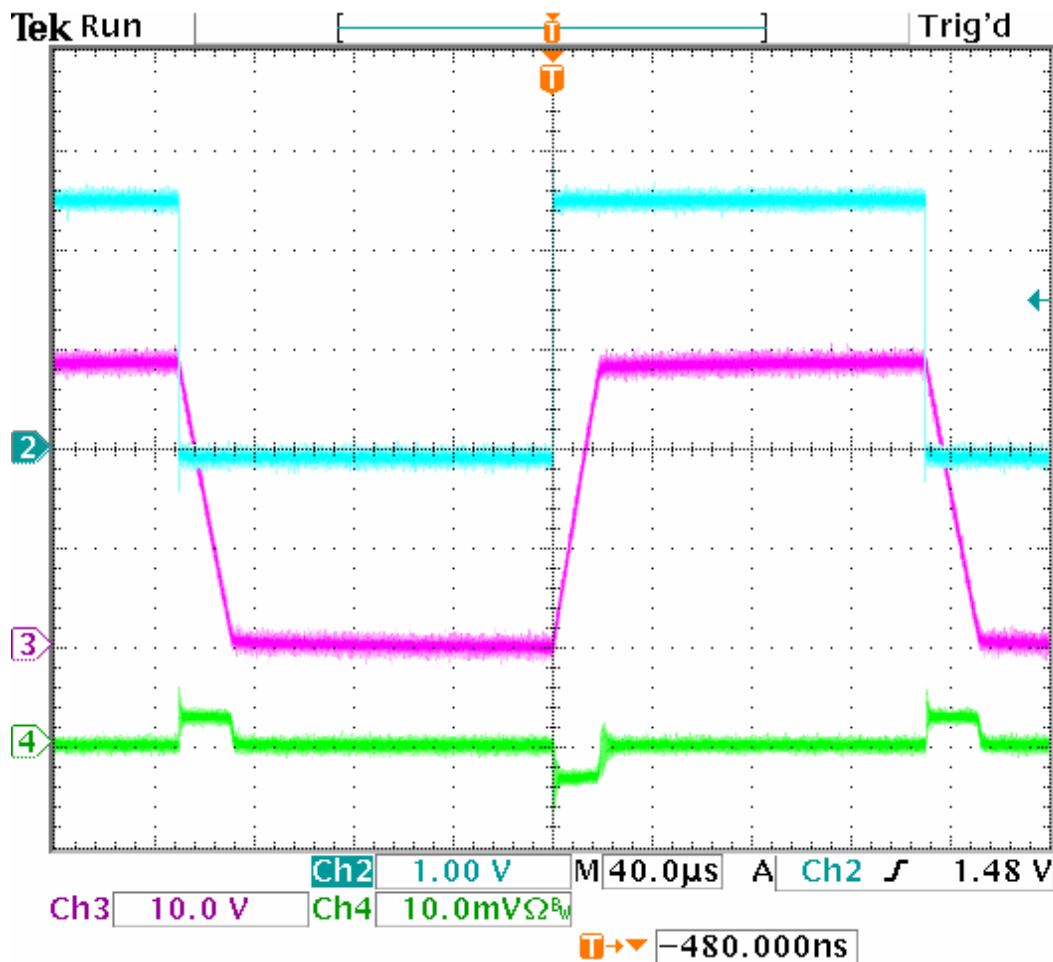
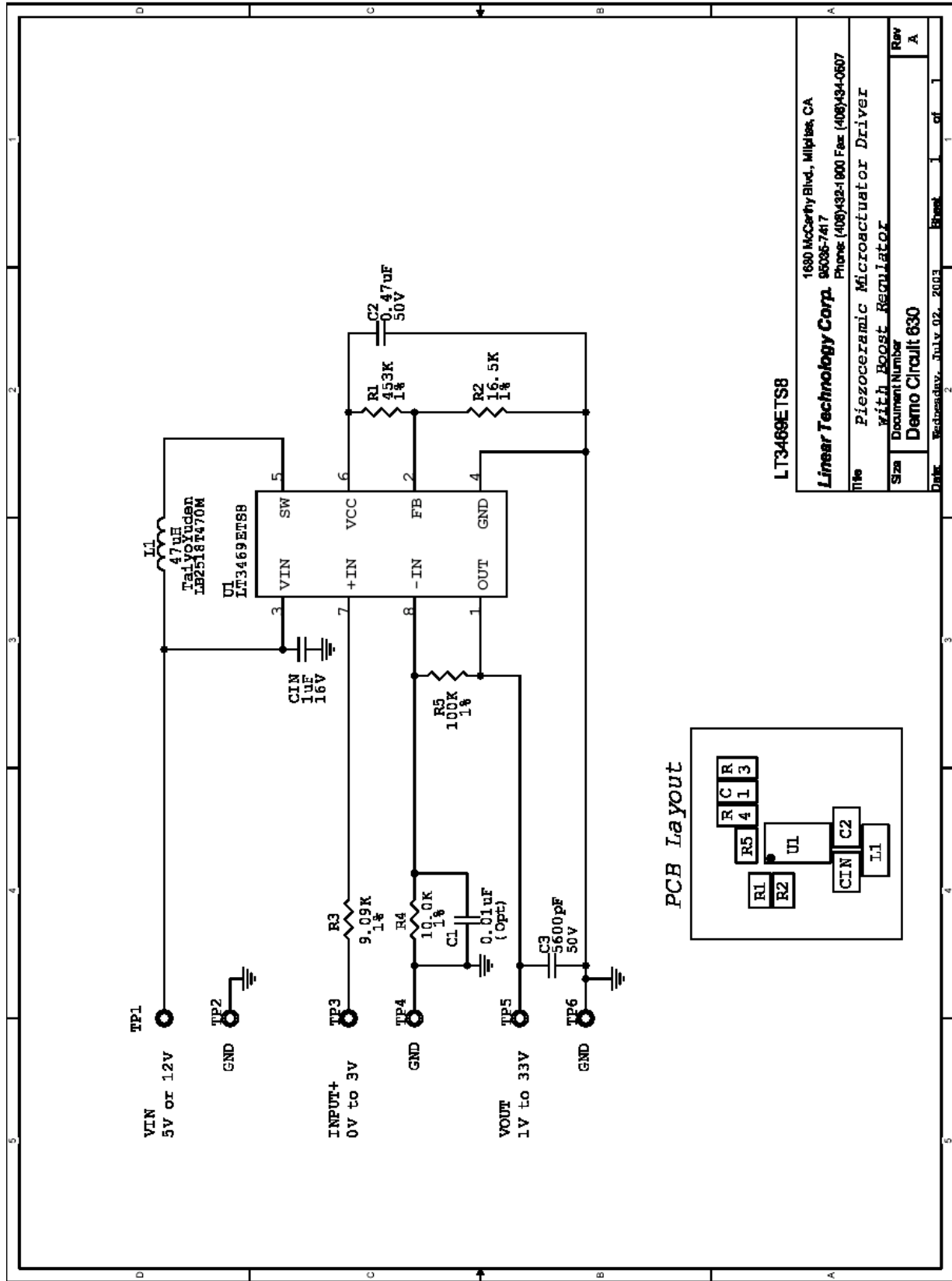

Figure 3. Ch2: Vinput. Ch3: Vout. Ch4: Iout, 100mA/Div

QUICK START GUIDE FOR DEMONSTRATION CIRCUIT 630

PIEZOCERAMIC MICROACTUATOR DRIVER WITH BOOST REGULATOR



LT3469ETS8

1680 McCarthy Blvd., Milpitas, CA	
Linear Technology Corp. 950386-7417	
Phone: (408)321-9000 Fax: (408)494-0807	
Title: Piezoceramic Microactuator Driver	
with Boost Regulator	
Size	Document Number
Rev	Demo Circuit 630
Date	Wednesday, July 02, 2003
Page	1 of 1

Mouser Electronics

Authorized Distributor

Click to View Pricing, Inventory, Delivery & Lifecycle Information:

[Analog Devices Inc.:](#)

[DC630A](#)