

LTM4660

High Efficiency, PolyPhase 100A Hybrid Step-Down Power μ Module Regulator 4x LTM4660, 100A

DESCRIPTION

Demonstration circuit 2959A-C is a high-efficiency, high-power-density hybrid step-down converter. It can deliver 12V/100A with an input voltage from 36V to 60V (up to 65V during transients). This demo board features PolyPhase[®] design using the [LTM[®]4660](#), which uses an architecture that merges soft-switching switched capacitor topology with a traditional step-down converter to provide superior efficiency compared to the traditional switching architectures. It offers a high efficiency/high density and cost-effective solution for nonisolated intermediate bus applications in power distribution, datacom, and telecom.

The LTM4660 on DC2959A-C always operates in continuous conduction mode. The switching frequency can be programmed through a resistor or can be synchronized to an external clock signal. Due to its current mode control architecture, excellent current sharing and low output voltage ripple are achievable in the multiphase configuration.

Other benefits include low Electromagnetic Interference (EMI) emissions due to a soft-switched front end and reduced MOSFET stress.

The LTM4660 monitors system voltage, current, and temperature for faults. It stops switching and pulls the **FAULT** pin low when a fault condition occurs. An onboard timer can be set for appropriate restart/retry times. Additional features include $\pm 1.5\%$ output voltage accuracy over temperature, a power good output signal, short-circuit protection, monotonic output voltage start-up, optional external reference, undervoltage lockout, and internal charge balance circuitry.

The LTM4660 data sheet must be used in conjunction with this demo board manual.

Design files for this circuit board are available.

All registered trademarks and trademarks are the property of their respective owners.

BOARD PHOTO Part marking is either ink mark or laser mark

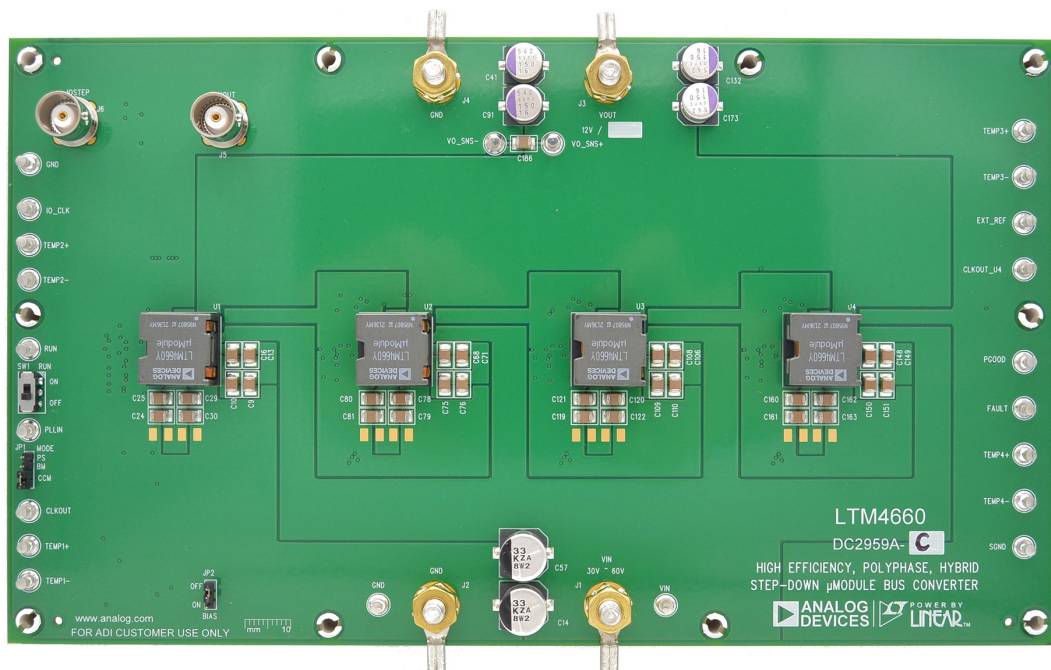

Figure 1. LTM4660/DC2959A-C Demo Circuit

PERFORMANCE SUMMARY Specifications are at $T_A = 25^\circ\text{C}$

PARAMETER	CONDITIONS	MIN	TYP	MAX	UNITS
Input Voltage Range		36		60	V
Output Voltage, V_{OUT}	$V_{IN} = 36\text{V to }60\text{V}$, $I_{OUT} = 0\text{A to }100\text{A}$			12	V
Maximum Output Current, I_{OUT}	$V_{IN} = 36\text{V to }60\text{V}$, $V_{OUT} = 12\text{V}$			100	A
Typical Efficiency	$V_{IN} = 48\text{V}$, $V_{OUT} = 12\text{V}$, $I_{OUT} = 100\text{A}$		96.8		%
Peak Efficiency	$V_{IN} = 48\text{V}$, $V_{OUT} = 12\text{V}$		97.2		%
Default Switching Frequency (at Start-Up)			350		kHz

QUICK START PROCEDURE

Demonstration circuit 2959A-C is easy to set up to evaluate the performance of the PolyPhase operation of the LTM4660. Due to the high input/output current, users should select the proper input supply/load/cable which can sustain the full load operation. See Figure 2 for the proper measurement equipment setup and follow the procedure below.

1. With power off, connect the input power supply to V_{IN} (36V to 60V) and GND (input return).
2. Connect the output load between V_{OUT} and GND (Initial load: no load). See Figure 2.
3. Connect the DVMs to the input and output.
4. Check the default jumper/switch position: SW1 (RUN): OFF
5. Turn on the input power supply and adjust the input voltage to 48V.

NOTE: Make sure that the input voltage does not exceed 60V.

6. Turn on the switches: SW1: ON.
7. Check for the proper output voltages from VO_SNS+ to VO_SNS- .
8. Once the proper output voltage is established, adjust the load within the operating range and measure the efficiency, output ripple voltage, and other items.
9. After completing all tests, adjust the load to 0A and power off the input power supply.

Notes

1. When measuring the output or input voltage ripple, do not use the long ground lead on the oscilloscope probe. See Figure 3 for the proper scope probe technique. Short, stiff leads need to be soldered to the (+) and (-) terminals of an output capacitor. The probe's ground ring needs to touch the (-) lead, and the probe tip needs to touch the (+) lead.
2. When doing the load step test with the onboard dynamic load circuit, please make sure the load step-up pulse duty cycle does not exceed 2%, and the pulse duration is less than 500 μs so that the temperature of the MOSFETs Q11 and Q12 in the dynamic load circuit stays in the safe region. Instead of using the onboard dynamic load circuit, an electric load can also be used for the load step test, which does not have the 2% max duty cycle limit for the load step.
3. The $EXTV_{CC}$ pin is connected by default to V_{OUT} through a jumper R3. Remove R3 before applying an external voltage to the $EXTV_{CC}$ pin.
4. Due to the feature of the controller inside LTM4660, it is normal to see increased switching frequency after long-time running, as higher temperature leads to higher switching frequency.

QUICK START PROCEDURE

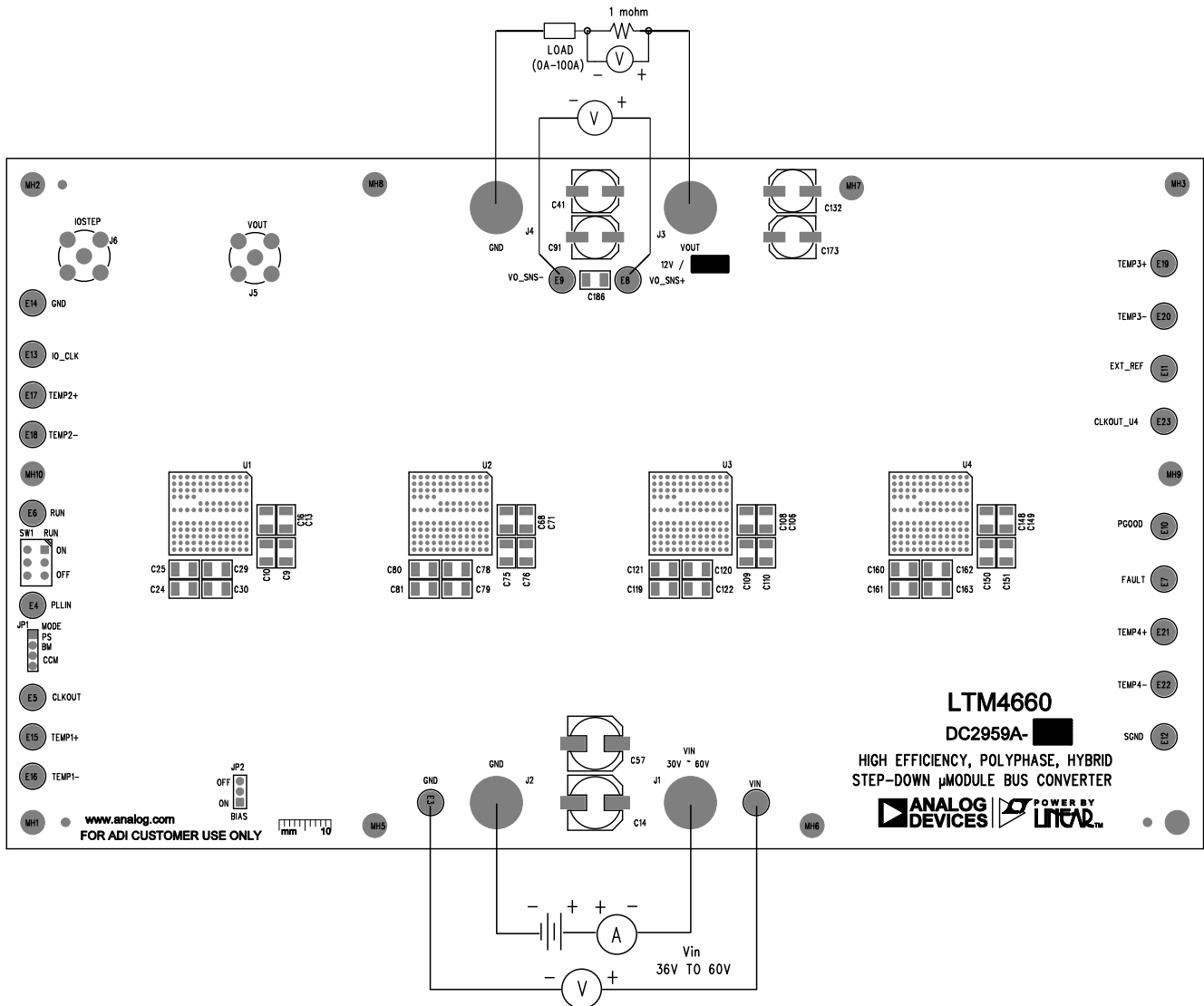

Figure 2. Proper Measurement Equipment Setup

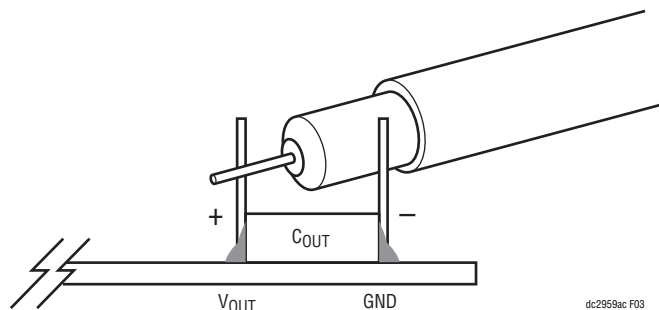

Figure 3. Measuring Output Voltage Ripple

TYPICAL PERFORMANCE CHARACTERISTICS

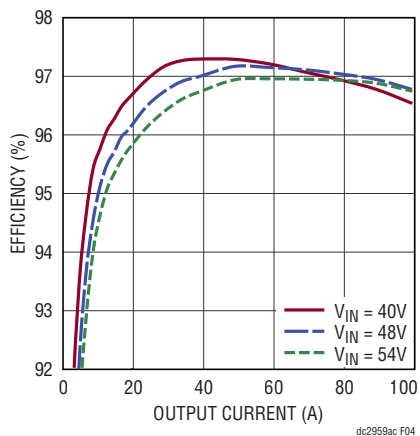

Figure 4. Efficiency vs Load Current at $V_{OUT} = 12V$, $f_{SW} = 350kHz$

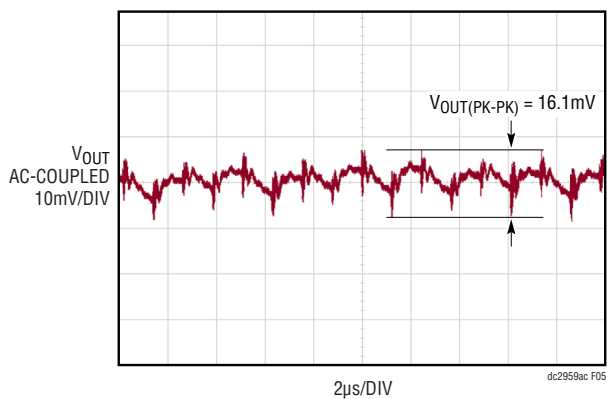

Figure 5. Output Voltage Ripple at $V_{IN} = 48V$, $V_{OUT} = 12V$, $I_{OUT} = 100A$, $f_{SW} = 350kHz$

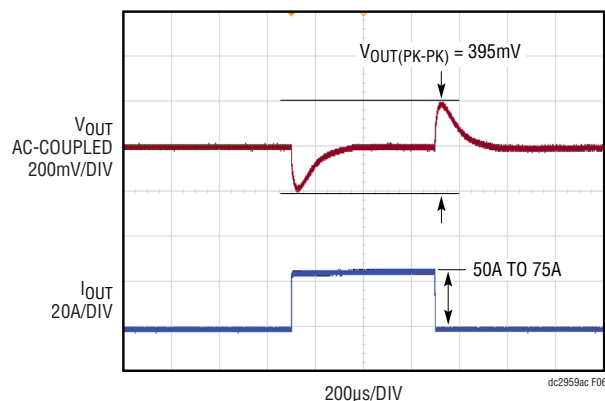

Figure 6. Load Step at $V_{IN} = 48V$, $V_{OUT} = 12V$, $f_{SW} = 350kHz$

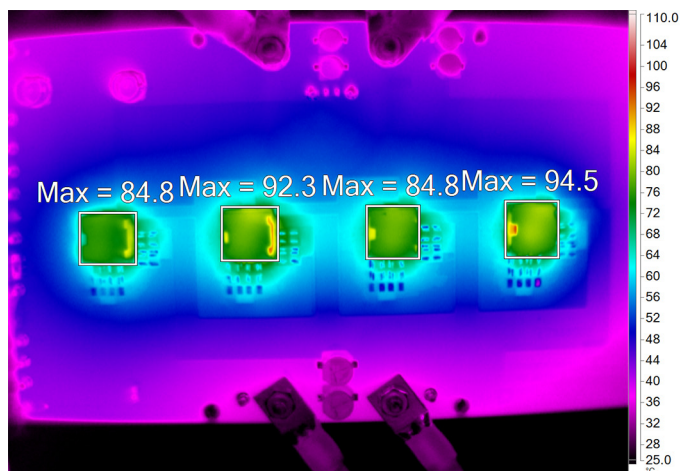

Figure 7. Thermal Performance $V_{IN} = 48V$, $V_{OUT} = 12V$, $I_{OUT} = 100A$, $f_{SW} = 400kHz$, $T_A = 25^\circ C$, 400LFM, No Heatsink

PARTS LIST

ITEM	QTY	REFERENCE	PART DESCRIPTION	MANUFACTURER/PART NUMBER
Required Circuit Components				
1	26	C1-C5, C15, C46, C47, C58-C63, C98-C103, C139-C144	CAP., 2.2 μ F, X7R, 100V, 10%, 1210	AVX, 12101C225KAT2A TDK, C3225X7R2A225K230AB MURATA, GRM32DR72A225KA12K; GRM32DR72A225KA12L
2	8	C6, C22, C64, C77, C104, C118, C145, C159	CAP., 2.2 μ F, X7R, 50V, 10%, 0805	AVX, 08055C225KAT2A NIC, NMC0805X7R225K50TRPLPF TDK, C2012X7R1H225K; C2012X7R1H225K125AC TAIYO YUDEN, UMK212BB7225KG-T
3	112	C7-C13, C16-C20, C23-C34, C38-C40, C65-C76, C78-C89, C93-C95, C105-C116, C119-C130, C134-C136, C146-C157, C160-C171, C175-C177, C183-C186	CAP., 10 μ F, X7S, 100V, 10%, 1210	MURATA, GRM32EC72A106KE05L
4	4	C14, C57, C97, C138	CAP., 33 μ F, ALUM. POLY. HYB., 80V, 20%, 10mm \times 10.2mm SMD, RADIAL, AEC-Q200	PANASONIC, EEHZA1K330P
5	4	C21, C90, C131, C172	CAP., 2.2 μ F, X7S, 25V, 10%, 0603	MURATA, GRM188C71E225KE11D
6	1	C36	CAP., 0.1 μ F, X7S, 100V, 10%, 0603	TAIYO YUDEN, HMK107C7104KA-T TDK, C1608X7S2A104K080AB
7	8	C41, C42, C91, C92, C132, C133, C173, C174	CAP., 150 μ F, ALUM., OS-CON, 16V, 20%, 8mm \times 6.9mm SMD, RADIAL	PANASONIC, 16SVPC150M
8	2	C49, C50	CAP., 22 μ F, X5R, 25V, 10%, 1210	KEMET, C1210C226K3PACTU MURATA, GRM32ER61E226KE15K; GRM32ER61E226KE15L SAMSUNG, CL32A226KAJNNNE TAIYO YUDEN, TMK325BJ226KM-P; TMK325BJ226KM-T AVX, 12103D226KAT2A
9	1	C51	CAP., 0.047 μ F, X7R, 25V, 10%, 0603	MURATA, GRM188R71E473KA01D NIC, NMC0603X7R473K25TRPF AVX, 06033C473KAT2A
10	1	C52	CAP., 220pF, C0G, 50V, 5%, 0603	AVX, 06035A221JAT2A MURATA, GRM1885C1H221JA01D WURTH ELEKTRONIK, 885012006059
11	1	C53	CAP., 1 μ F, X7R, 25V, 10%, 0603, AEC-Q200	MURATA, GCM188R71E105KA64D TAIYO YUDEN, TMK107AB7105KAHT TDK, CGA3E1X7R1E105K080AC
12	1	L3	IND., 68 μ H, PWR, SHIELDED, 20%, 0.74A, 0.42 Ω , 2424, LPS6225	COILCRAFT, LPS6225-683MRB; LPS6225-683MRC
13	2	Q11, Q12	XSTR., MOSFET, N-CH, 40V, 14A, DPAK (TO-252)	VISHAY, SUD50N04-8M8P-4GE3
14	24	R1, R3, R9, R12, R16, R18, R26, R30, R36, R37, R40, R41-R44, R48, R50-R53, R58, R60, R61, R65	RES., 0 Ω , 1/10W, 0603, AEC-Q200	VISHAY, CRCW06030000Z0EA; CRCW06030000Z0EB; CRCW06030000Z0EC NIC, NRC06ZOTRF
15	2	R2, R22	RES., 20k, 5%, 1/10W, 0603, AEC-Q200	NIC, NRC06J203TRF VISHAY, CRCW060320K0JNEA PANASONIC, ERJ3GEYJ203V
16	1	R4	RES., 1M, 1%, 1/8W, 0805, AEC-Q200	PANASONIC, ERJ6ENF1004V VISHAY, CRCW08051M00FKEA
17	1	R5	RES., 46.4k, 1%, 1/10W, 0603	NIC, NRC06F4642TRF VISHAY, CRCW060346K4FKEA YAGEO, RC0603FR-0746K4L

DEMO MANUAL DC2959A-C

PARTS LIST

ITEM	QTY	REFERENCE	PART DESCRIPTION	MANUFACTURER/PART NUMBER
18	3	R6, R13, R24	RES., 10k, 1%, 1/10W, 0603, AEC-Q200	VISHAY, CRCW060310K0FKEA KOA SPEER, RK73H1JTTD1002F PANASONIC, ERJ3EKF1002V
19	4	R7, R38, R45, R55	RES., 100k, 1%, 1/10W, 0603, AEC-Q200	VISHAY, CRCW0603100KFKEA NIC, NRC06F1003TRF PANASONIC, ERJ3EKF1003V YAGEO, RC0603FR-07100KL
20	4	R10, R39, R46, R56	RES., 49.9k, 1%, 1/10W, 0603	NIC, NRC06F4992TRF VISHAY, CRCW060349K9FKEA YAGEO, RC0603FR-0749K9L
21	1	R19	RES., 1.07k, 1%, 1/10W, 0603, AEC-Q200	PANASONIC, ERJ3EKF1071V VISHAY, CRCW06031K07FKEA
22	1	R21	RES., 182k, 1%, 1/10W, 0603, AEC-Q200	PANASONIC, ERJ3EKF1823V VISHAY, CRCW0603182KFKEA
23	1	R23	RES., 80.6k, 1%, 1/10W, 0603	VISHAY, CRCW060380K6FKEA NIC, NRC06F8062TRF YAGEO, RC0603FR-0780K6L
24	1	R25	RES., 0.1Ω, 1%, 1W, 2010, WSL-18 SERIES, SENSE, AEC-Q200	VISHAY, WSL2010R1000FEA18
25	1	R62	RES., 50Ω, 0.1%, 1/8W, 0603	VISHAY, FC0603E50R0BST1
26	4	U1-U4	IC, HYBRID STEP-DOWN NONISOLATED μModule [®] BUS CONVERTER, BGA	ANALOG DEVICES, LTM4660IY#PBF
27	1	U5	IC, SYNCHR. STEP-DOWN CONVERTER, MSOP-16 (MSE), 76V, 500mA	ANALOG DEVICES, LTC3630AEMSE#PBF; LTC3630AEMSE#TRPBF

Additional Demo Board Circuit Components

1	0	C35, C37, C43-C45, C48, C54, C96, C137, C178-C182	CAP., OPTION, 0603	
2	0	R8	RES., OPTION, 0805	
3	0	R14, R15, R17, R20, R29, R47, R57, R63, R64	RES., OPTION, 0603	
4	0	RN1-RN4	THERMISTOR, OPTION, 0603	

Hardware: For Demo Board Only

1	22	E2-E23	TEST POINT, TURRET, 0.094" MTG. HOLE, PCB 0.062" THK	MILL-MAX, 2501-2-00-80-00-00-07-0
2	4	J1-J4	EVAL BOARD STUD HARDWARE SET, #10-32	ANALOG DEVICES, 720-0010
3	2	J5, J6	CONN., RF, BNC, RCPT, JACK, 5-PIN, ST, THT, 50Ω	AMPHENOL RF, 112404
4	1	JP1	CONN., HDR, MALE, 1×4, 2mm, VERT, ST, THT	WURTH ELEKTRONIK, 62000411121
5	1	JP2	CONN., HDR, MALE, 1×3, 2mm, VERT, ST, THT, NO SUBS. ALLOWED	WURTH ELEKTRONIK, 62000311121
6	1	LB1	LABEL SPEC, DEMO BOARD SERIAL NUMBER	BRADY, THT-96-717-10
7	10	MH1-MH10	STANDOFF, NYLON, SNAP-ON, 0.625" (5/8), 15.9mm	KEYSTONE, 8834
8	1	PCB1	PCB, DC2959A	ANALOG DEVICES APPROVED SUPPLIER, 600-DC2959A
9	1	STNCL1	TOOL, STENCIL, DC2959A	ANALOG DEVICES APPROVED SUPPLIER, 830-DC2959A
10	1	SW1	SWITCH, SLIDE, DPDT, 0.3A, 6VDC, PTH	C&K, JS202011CQN
11	2	XJP1, XJP2	CONN., SHUNT, FEMALE, 2 POS, 2mm	WURTH ELEKTRONIK, 60800213421

SCHEMATIC DIAGRAM

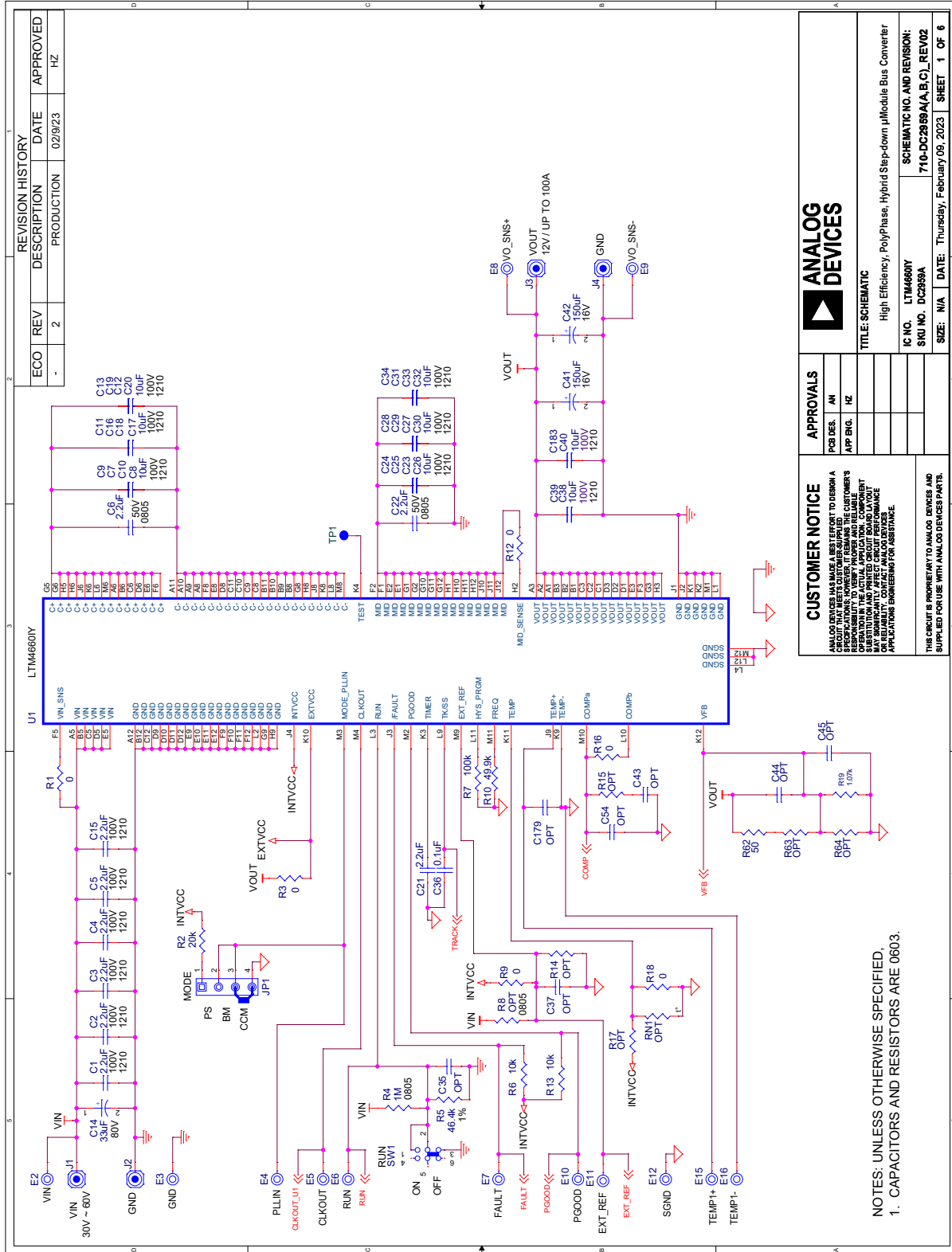

REVISION HISTORY				
ECO	REV	DESCRIPTION	DATE	APPROVED
-	2	PRODUCTION	02/9/23	HZ

ANALOG DEVICES

High Efficiency, PolyPhase, Hybrid Step-down µModule Bus Converter

TITLE: SCHEMATIC

IC NO. LTM4600Y

SKU NO. DC2959A

SIZE: N/A

DATE: Thursday, February 09, 2023

SHEET 1 OF 6

CUSTOMER NOTICE

ANALOG DEVICES MAKES NO WARRANTY TO DEMONSTRATE SPECIFIC PERFORMANCE. HOWEVER, IT REMAINS THE CUSTOMER'S RESPONSIBILITY TO VERIFY THE PERFORMANCE OF THE COMPONENTS IN THE ACTUAL APPLICATION. COMPONENTS MAY VARY FROM THE PARTS LISTED IN THIS SCHEMATIC AND MAY SIGNIFICANTLY AFFECT CIRCUIT PERFORMANCE OR RELIABILITY. CONTACT ANALOG DEVICES APPLICATION ENGINEERING FOR ASSISTANCE.

THIS CIRCUIT IS PROPRIETARY TO ANALOG DEVICES AND IS SUPPLIED FOR USE WITH ANALOG DEVICES PARTS.

NOTES: UNLESS OTHERWISE SPECIFIED.
1. CAPACITORS AND RESISTORS ARE 0603.

SCHEMATIC DIAGRAM

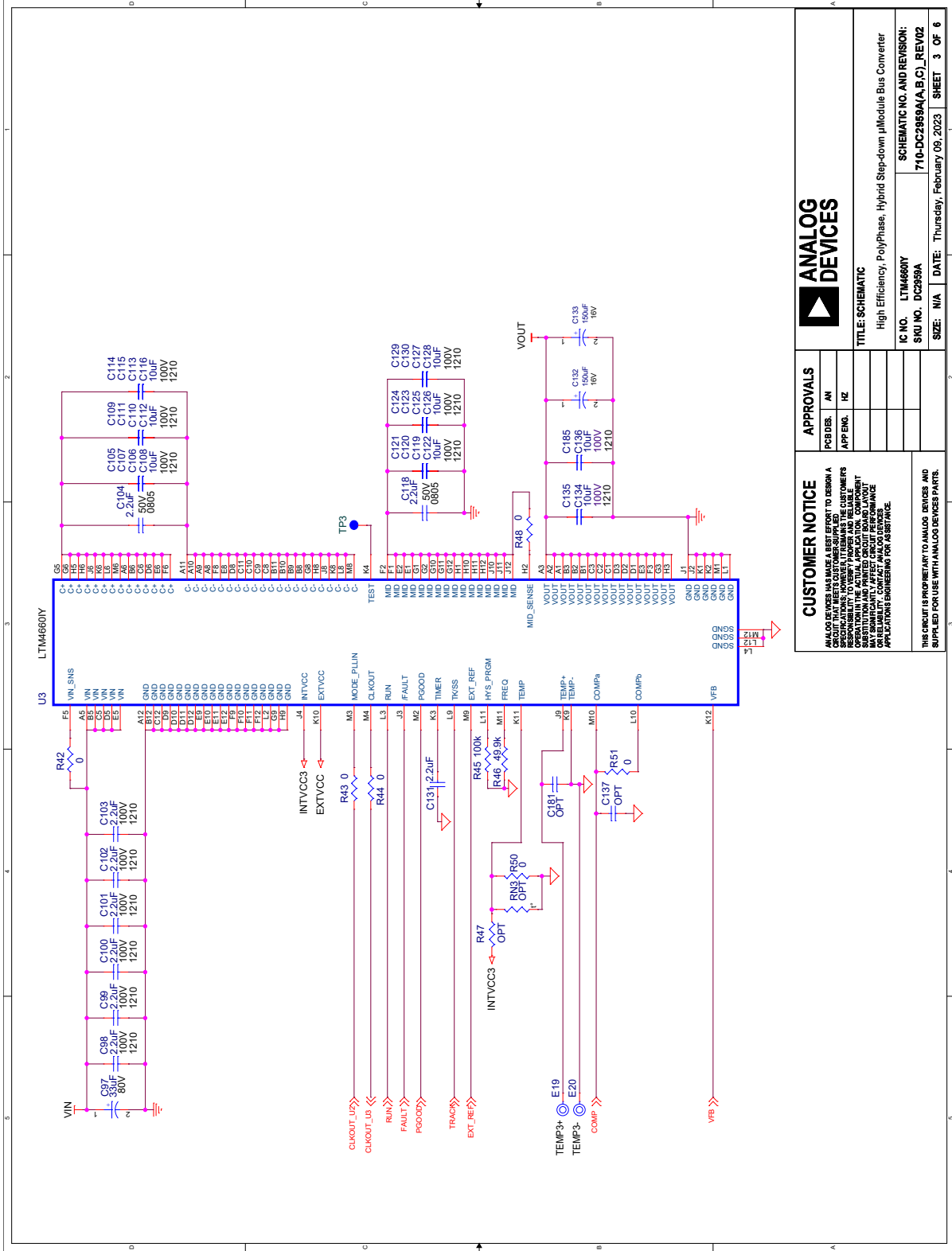

	APPROVALS	
	PCB DES: AH	APP ENG: HZ
CUSTOMER NOTICE ANALOG DEVICES HAS MADE BEST EFFORT TO DESIGN A SPECIFICATION. HOWEVER, IT REMAINS THE CUSTOMER'S RESPONSIBILITY TO VERIFY THE OPERATION OF THE COMPONENT IN THE ACTUAL APPLICATION. COMPONENT PERFORMANCE MAY VARY FROM THE SPECIFIED PERFORMANCE. ANALOG DEVICES ASSUMES NO LIABILITY FOR ANY CIRCUIT PERFORMANCE APPLICATIONS ENGINEERING FOR ADVANTAGE.		
TITLE: SCHEMATIC High Efficiency, PolyPhase, Hybrid Step-down μ Module Bus Converter		
IC NO. LTM4600Y	SCHEMATIC NO. AND REVISION: 710-DC2959A(A,B,C)_REV02	
SKU NO. DC2959A	SIZE: N/A	DATE: Thursday, February 09, 2023 SHEET 3 OF 6
THIS CIRCUIT IS PROPRIETARY TO ANALOG DEVICES, AND SUPPLIED FOR USE WITH ANALOG DEVICES PARTS.		

SCHEMATIC DIAGRAM

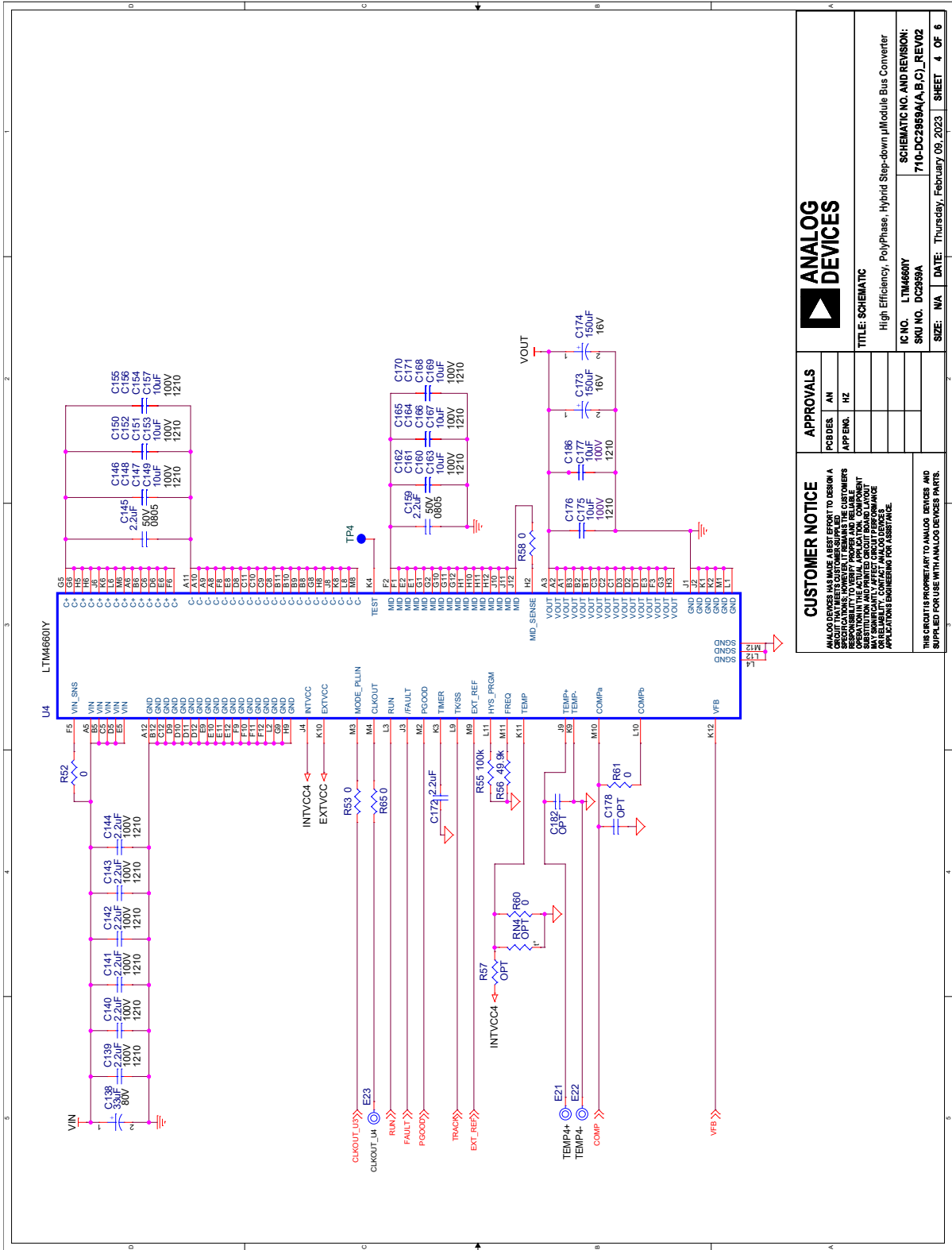

CUSTOMER NOTICE	ANALOG DEVICES HAS MADE A BEST EFFORT TO DESIGN A SPECIFICATION THAT MEETS THE CUSTOMER'S REQUIREMENTS. ANALOG DEVICES ASSUMES NO RESPONSIBILITY FOR ANY ERRORS OR OMISSIONS IN THIS SCHEMATIC. ANALOG DEVICES ASSUMES NO LIABILITY FOR ANY PRINTING OR REPRODUCTION ERRORS. ANALOG DEVICES ASSUMES NO LIABILITY FOR ANY DAMAGE TO PERSONS OR PROPERTY ARISING FROM THE USE OF THIS SCHEMATIC. FOR RELIABILITY, CONTACT ANALOG DEVICES APPLICATION ENGINEERING FOR ASSISTANCE.	
	THIS SCHEMATIC IS INTENDED FOR ANALOG DEVICES AND SUPPLIERS FOR USE WITH ANALOG DEVICES PARTS.	
APPROVALS	PCB DES:	AN
	APP ENG:	RZ
TITLE: SCHEMATIC		
High Efficiency, PolyPhase, Hybrid Step-down μ Module Bus Converter		
IC NO.:	LTM4660Y	SCHEMATIC NO. AND REVISION:
SKU NO.:	DC2959A	710-DC2959A(A,B,C)_REV02
SIZE:	NA	DATE: Thursday, February 09, 2023
SHEET 4 OF 6		

SCHEMATIC DIAGRAM

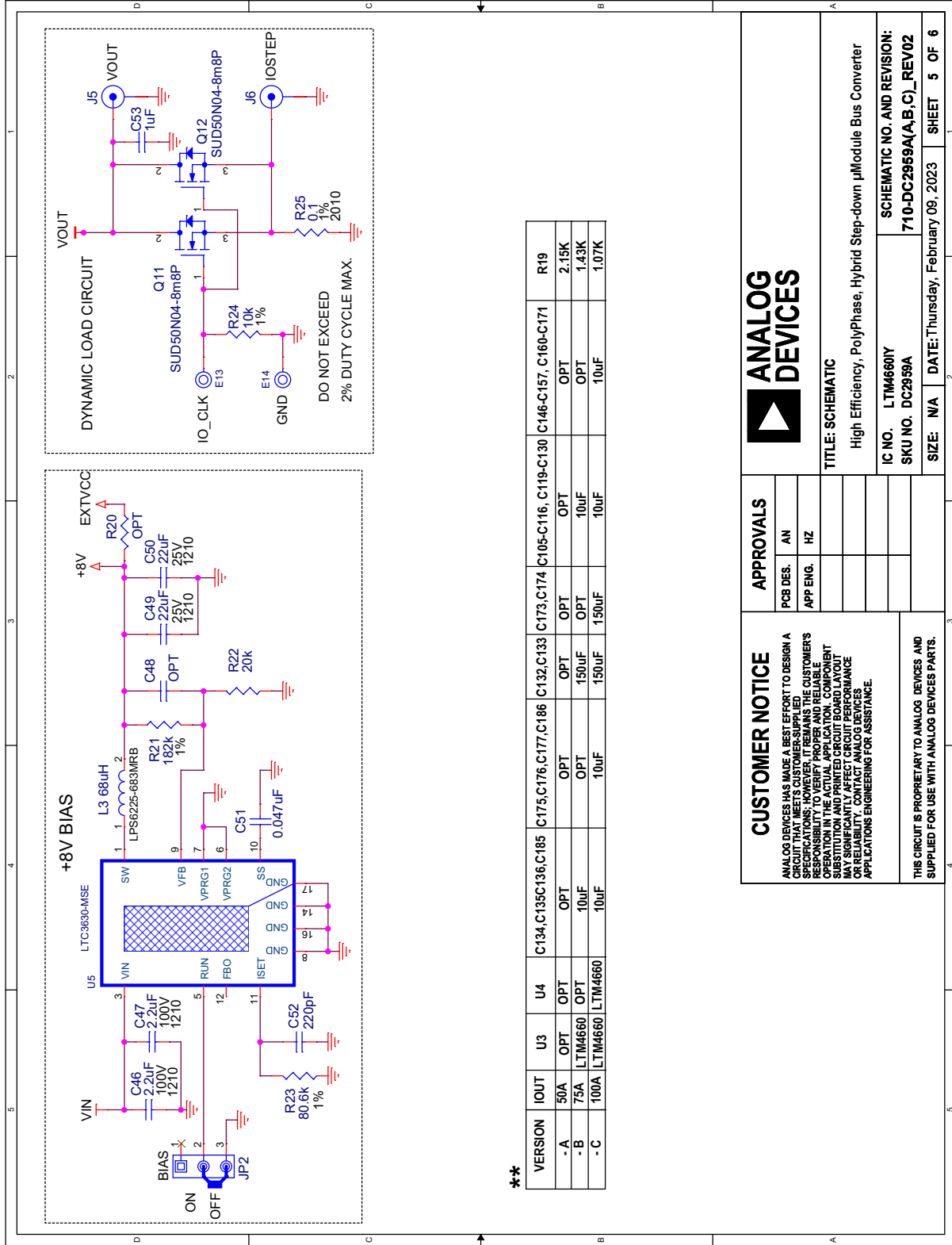

SCHEMATIC DIAGRAM

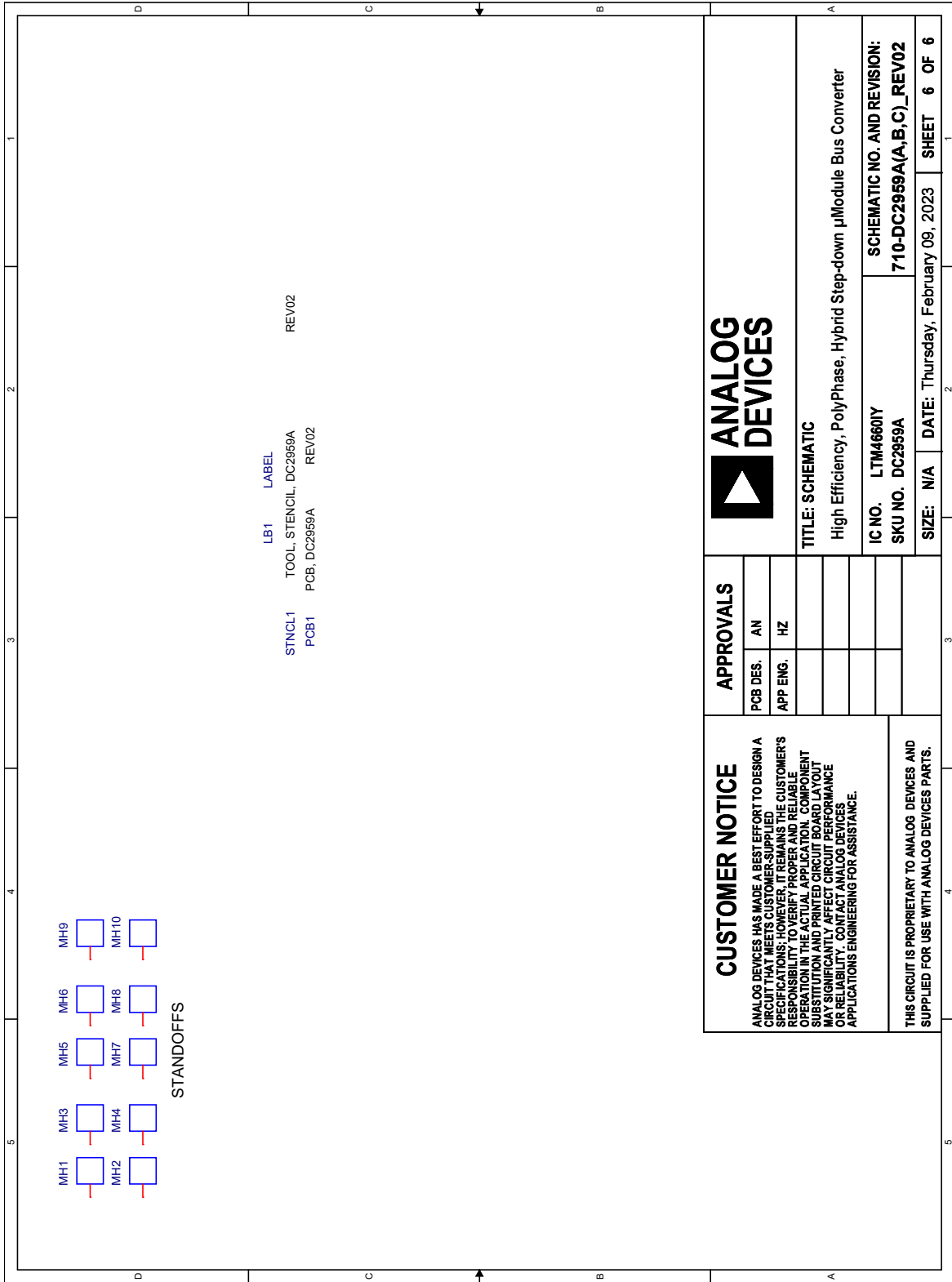

REVISION HISTORY

REV	DATE	DESCRIPTION	PAGE NUMBER
0	06/23	Initial Release.	—



ESD Caution

ESD (electrostatic discharge) sensitive device. Charged devices and circuit boards can discharge without detection. Although this product features patented or proprietary protection circuitry, damage may occur on devices subjected to high energy ESD. Therefore, proper ESD precautions should be taken to avoid performance degradation or loss of functionality.

Legal Terms and Conditions

By using the evaluation board discussed herein (together with any tools, components documentation or support materials, the "Evaluation Board"), you are agreeing to be bound by the terms and conditions set forth below ("Agreement") unless you have purchased the Evaluation Board, in which case the Analog Devices Standard Terms and Conditions of Sale shall govern. Do not use the Evaluation Board until you have read and agreed to the Agreement. Your use of the Evaluation Board shall signify your acceptance of the Agreement. This Agreement is made by and between you ("Customer") and Analog Devices, Inc. ("ADI"), with its principal place of business at One Technology Way, Norwood, MA 02062, USA. Subject to the terms and conditions of the Agreement, ADI hereby grants to Customer a free, limited, personal, temporary, non-exclusive, non-sublicensable, non-transferable license to use the Evaluation Board FOR EVALUATION PURPOSES ONLY. Customer understands and agrees that the Evaluation Board is provided for the sole and exclusive purpose referenced above, and agrees not to use the Evaluation Board for any other purpose. Furthermore, the license granted is expressly made subject to the following additional limitations: Customer shall not (i) rent, lease, display, sell, transfer, assign, sublicense, or distribute the Evaluation Board; and (ii) permit any Third Party to access the Evaluation Board. As used herein, the term "Third Party" includes any entity other than ADI, Customer, their employees, affiliates and in-house consultants. The Evaluation Board is NOT sold to Customer; all rights not expressly granted herein, including ownership of the Evaluation Board, are reserved by ADI. CONFIDENTIALITY. This Agreement and the Evaluation Board shall all be considered the confidential and proprietary information of ADI. Customer may not disclose or transfer any portion of the Evaluation Board to any other party for any reason. Upon discontinuation of use of the Evaluation Board or termination of this Agreement, Customer agrees to promptly return the Evaluation Board to ADI. ADDITIONAL RESTRICTIONS. Customer may not disassemble, decompile or reverse engineer chips on the Evaluation Board. Customer shall inform ADI of any occurred damages or any modifications or alterations it makes to the Evaluation Board, including but not limited to soldering or any other activity that affects the material content of the Evaluation Board. Modifications to the Evaluation Board must comply with applicable law, including but not limited to the RoHS Directive. TERMINATION. ADI may terminate this Agreement at any time upon giving written notice to Customer. Customer agrees to return to ADI the Evaluation Board at that time. LIMITATION OF LIABILITY. THE EVALUATION BOARD PROVIDED HEREUNDER IS PROVIDED "AS IS" AND ADI MAKES NO WARRANTIES OR REPRESENTATIONS OF ANY KIND WITH RESPECT TO IT. ADI SPECIFICALLY DISCLAIMS ANY REPRESENTATIONS, ENDORSEMENTS, GUARANTEES, OR WARRANTIES, EXPRESS OR IMPLIED, RELATED TO THE EVALUATION BOARD INCLUDING, BUT NOT LIMITED TO, THE IMPLIED WARRANTY OF MERCHANTABILITY, TITLE, FITNESS FOR A PARTICULAR PURPOSE OR NON-INFRINGEMENT OF INTELLECTUAL PROPERTY RIGHTS. IN NO EVENT WILL ADI AND ITS LICENSORS BE LIABLE FOR ANY INCIDENTAL, SPECIAL, INDIRECT, OR CONSEQUENTIAL DAMAGES RESULTING FROM CUSTOMER'S POSSESSION OR USE OF THE EVALUATION BOARD, INCLUDING BUT NOT LIMITED TO LOST PROFITS, DELAY COSTS, LABOR COSTS OR LOSS OF GOODWILL. ADI'S TOTAL LIABILITY FROM ANY AND ALL CAUSES SHALL BE LIMITED TO THE AMOUNT OF ONE HUNDRED US DOLLARS (\$100.00). EXPORT. Customer agrees that it will not directly or indirectly export the Evaluation Board to another country, and that it will comply with all applicable United States federal laws and regulations relating to exports. GOVERNING LAW. This Agreement shall be governed by and construed in accordance with the substantive laws of the Commonwealth of Massachusetts (excluding conflict of law rules). Any legal action regarding this Agreement will be heard in the state or federal courts having jurisdiction in Suffolk County, Massachusetts, and Customer hereby submits to the personal jurisdiction and venue of such courts. The United Nations Convention on Contracts for the International Sale of Goods shall not apply to this Agreement and is expressly disclaimed.

Mouser Electronics

Authorized Distributor

Click to View Pricing, Inventory, Delivery & Lifecycle Information:

[Analog Devices Inc.:](#)

[DC2959A-C](#)