

LT3120
**26V, 9A Synchronous Buck-Boost DC/DC Converter
with Accurate Programmable Output Current Limit**
DESCRIPTION

Demonstration circuit 2815A features the **LT[®]3120**, as wide operating range synchronous monolithic buck-boost converter with programmable output current limit.

The DC2815A demo board has four user selectable operating modes:

- An accurate programmable EN/UVLO pin which is used to ENABLE the converter (JP1).
- Programmable MPPC (Maximum Power Point Control) for Input Regulation Set Point (JP2).
- Burst Mode[®] operation and External CLK/Fixed Frequency PWM (JP3).
- Programmable Output Average Current Limit Set Point (JP4).

The LT3120 uses average current mode control to simplify voltage loop compensation and provide good line and load transient response.

The DC2815A operates with a 2.5V to 26V input voltage range. The demo board has been designed with the output voltage set to 5V. The LT3120 incorporates a proprietary low noise switching algorithm which optimizes efficiency with input voltages above, below or equal to the output voltage and ensures seamless transitions between operating modes.

In PWM mode, the switching frequency can operate between 400kHz to 2MHz by programming the R_T resistor R5. LT3120 can be synchronized to an External CLK provided R_T is programmed 25% to 50% below the synchronization frequency.

The LT3120 has an optional programmable current limit that can be used to control the output current. The current limit circuit requires an external sense resistor connected between ISP and ISN and the current limit value can be set by adjusting R6 and C26 connected to PROG pin.

LT3120 also has programmable MPPC feature to set the input regulation voltage and can be adjusted by changing R13, R14 and C28.

Figure 2 shows typical demo board efficiency. Figure 3 and Figure 4 shows the load step response.

The LT3120 data sheet has detailed information about the operation, specifications, and applications of the part. The data sheet should be read in conjunction with this quick start guide.

[Design files for this circuit board are available.](#)

All registered trademarks and trademarks are the property of their respective owners.

PERFORMANCE SUMMARY Specifications are at $T_A = 25^\circ\text{C}$

PARAMETER	CONDITION	MIN	TYP	MAX	UNIT
Input Voltage V_{IN} Range	Operating	2.5		26	V
Switching Frequency (f_{SW})	R5 = 75k		1		MHz
Output Voltage V_{OUT}	R2 = 1M, R3 = 187k		5		V
Output Current I_{OUT}	$V_{IN} > 5V$		6.5		A
Efficiency			See Figure 2		%

Note: Demo board output current is a function of input voltage. Please refer to the data sheet for more information.

QUICK START PROCEDURE

Using short twisted pair leads for any power connections and with all loads and power supplies off, refer to Figure 1 for the proper measurement and equipment setup. The Power Supply (PS1) should not be connected to the circuit until told to do so in the procedure below.

When measuring the input or output voltage ripple, care must be taken to avoid a long ground lead on the oscilloscope probe. Measure the input or output voltage ripple by touching the probe tip directly across the VIN or VOUT and GND terminals, or by using an oscilloscope probe tip jack.

1. Jumper and PS1 settings to start:
 - PS1 = OFF
 - LOAD = OFF
 - JP1 (EN) = ON
 - JP2 (MPPC) = OFF
 - JP3 (MODE) = FIXED FREQ
 - JP4 (PROG) = OFF
2. With power OFF connect the power supply (PS1) as shown in Figure 1. If accurate current measurements are desired (for efficiency calculations for example) connect an ammeter in series with the supply as shown. The ammeter is not required however.
3. Turn on PS1 and slowly increase voltage until the voltage at VIN is 12V.
4. Verify VOUT is ~5V.
5. Connect a 5A load to VOUT as shown in Figure 1 (1Ω for VOUT = 5V). Connect an ammeter if accurate current measurement or monitoring is desired.
6. VIN can now be varied between 2.5V and 26V. IOU needs to be reduced for VIN < VOUT to ensure VOUT remains in regulation.
7. Load current (IOU) can also be varied. The maximum IOU is a function of VIN and the current limit. Consult the data sheet for more information on IOU vs VIN. For VIN > VOUT, IOU can be increased to 6.5A. For VIN < 5V, maximum IOU is reduced. This reduction is due to IIN increasing as VIN decreases. Once the input current limit is reached, VOUT will drop out of regulation.

NOTE: If VOUT drops out of regulation, check to be sure the maximum load has not been exceeded, or that VIN is not below the minimum value (2.5V).
8. For operation in BURST Mode move Jumper JP3 to BURST. See the data sheet for more information.
9. For programmable output current limit feature move JP4 to ILIM. Output current IOU will now be limited to 4A. See the data sheet for information on adjusting the limit.

QUICK START PROCEDURE

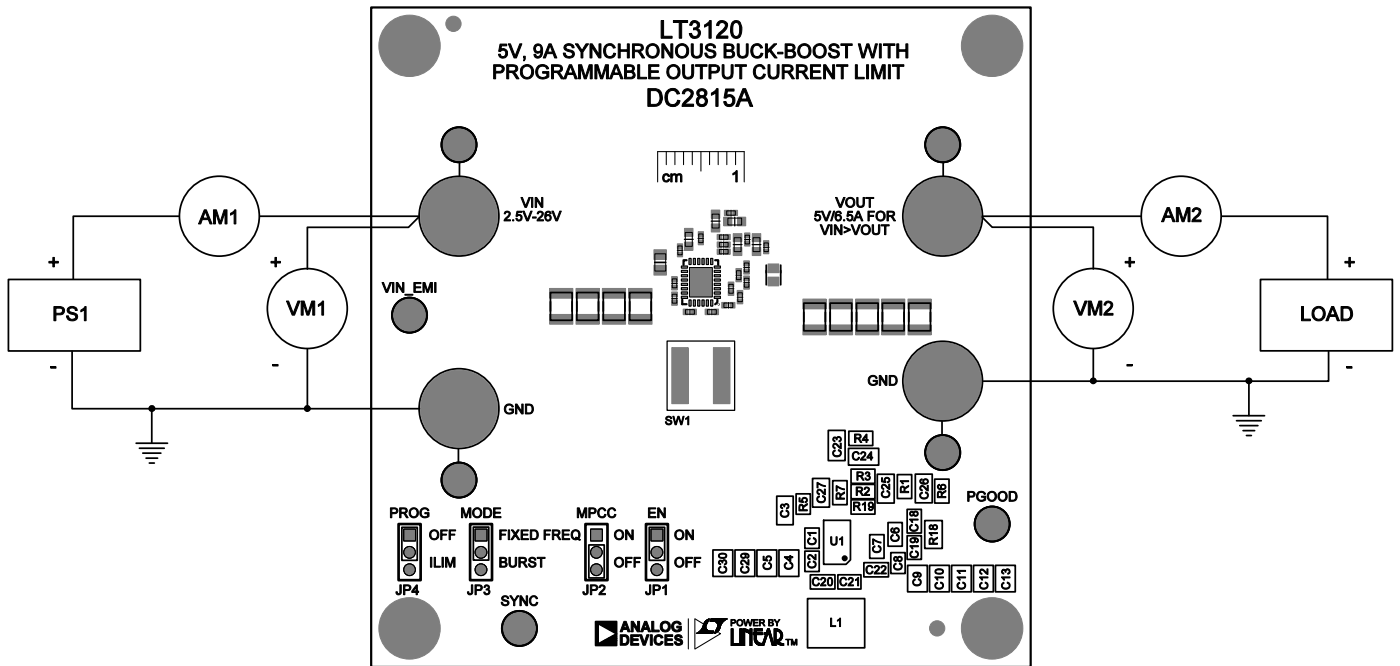

Figure 1. Test Procedure Setup Drawing for DC2815A

QUICK START PROCEDURE

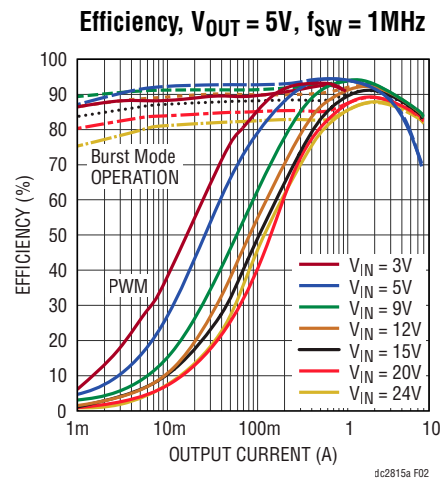

Figure 2. DC2815A Efficiency vs Output Current

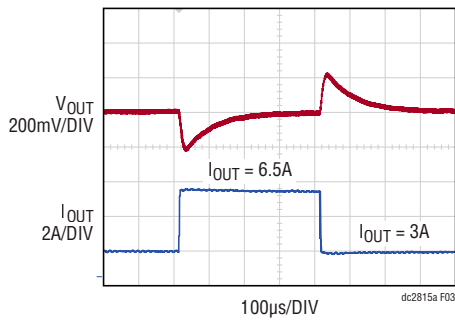

Figure 3. DC2815A Step Load Transient $I_{OUT} = 3A$ to $6.5A$ at $V_{IN} = 26V$

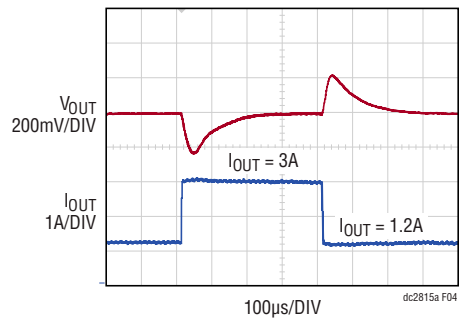

Figure 4. DC2815A Step Load Transient $I_{OUT} = 1.2A$ to $3A$ at $V_{IN} = 3.6V$

QUICK START PROCEDURE

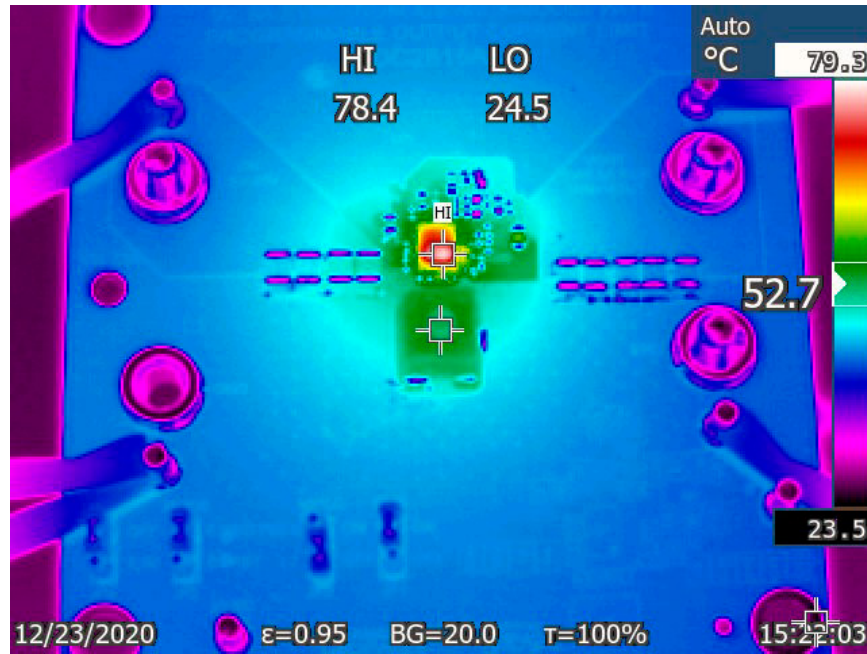

Figure 5. DC2815A Thermal Image for a 12V Input Delivering 5V at 5A

DEMO MANUAL DC2815A

PARTS LIST

ITEM	QTY	REFERENCE	PART DESCRIPTION	MANUFACTURER/PART NUMBER
Required Circuit Components				
1	7	C1, C2, C6-C8, C20-C21	CAP., 0.1µF, X7R, 25V, 10%, 0402, AEC-Q200	MURATA, GCM155R71E104KE02D
2	1	C3	CAP., 1µF, X7R, 50V, 10%, 0805	TAIYO YUDEN, UMK212B7105KG-T
3	4	C4, C5, C29, C30	CAP., 10µF, X5R, 50V, 10%, 1210	TDK, C3225X5R1H106K250AB
4	5	C9-C13	CAP., 100µF, X5R, 10V, 20%, 1210	KEMET, C1210C107M8PACTU
5	1	C22	CAP., 0.022µF, X7R, 16V, 10%, 0402	AVX, 0402YC223KAT2A
6	1	C23	CAP., 1200pF, X7R, 50V, 5%, 0603	AVX, 06035C122JAT2A
7	3	C24, C26, C28	CAP., 27pF, C0G, 25V, 5%, 0603	MURATA, GQM1875C2E270JB12D
8	1	C27	CAP., 4.7µF, X5R, 6.3V, 20%, 0603	AVX, 06036D475MAT2A
9	1	L1	IND., 3.3µH, PWR, SHIELDED, 20%, 15.1A, 9.42mΩ, 8mm × 7.7mm, AEC-Q200	COILCRAFT, XAL7070-332MEB
10	1	R1	RES., 49.9Ω, 1%, 1/16W, 0402, AEC-Q200	NIC, NRC04F49R9TRF
11	2	R2, R15	RES., 1M, 1%, 1/16W, 0402, AEC-Q200	STACKPOLE ELECTRONICS, INC., RMCFO402FT1M00
12	1	R3	RES., 187k, 1%, 1/16W, 0402	VISHAY, CRCW0402187KFKED
13	1	R4	RES., 64.9k, 1%, 1/16W, 0402, AEC-Q200	NIC, NRC04F6492TRF
14	1	R5	RES., 75.0k, 1%, 1/16W, 0402	VISHAY, MCS04020C7502FE000
15	1	R6	RES., 10k, 0.1%, 1/16W, 0402	YAGEO, RT0402BRD0710KL
16	1	R7	RES., 0Ω, 1/16W, 0402, AEC-Q200	NIC, NRC04Z0TRF
17	3	R8, R9, R12	RES., 2M, 1%, 1/16W, 0402, AEC-Q200	VISHAY, CRCW04022M00FKED
18	1	R16	RES., 1k, 1%, 1/16W, 0402	NIC, NRC04F1001TRF
19	1	R18	RES., 0.01Ω, 1%, 1W, 0805, HIGH PWR, METAL, SENSE, AEC-Q200	VISHAY, WSLP0805R0100FEA18
20	1	U1	IC, 26V, 9A SYNCHRONOUS BUCK-BOOST DC/DC CONVERTER	ANALOG DEVICES, INC., LT3120JV#PBF
Additional Demo Board Circuit Components				
1	0	C14, C15	CAP., OPTION, 1210	
2	0	C16	CAP., 10µF, X5R, 50V, 20%, 1206, OPTION	TDK, C3216X5R1H106M160AB
3	0	C17	CAP., 330µF, ALUM, POLY, 35V, 20%, RADIAL, SMD, AEC-Q200, OPTION	PANASONIC, EEH-ZK1V331P
4	0	C18, C19	CAP., OPTION, 0402	
5	0	C25	CAP., OPTION, 0603	
6	0	L2	FIXED IND 1µH 11.5A 4.75MΩ, OPTION	WURTH ELEKTRONIK, 744316100
7	0	PCB1	PCB, DC2815A	MAO BANG, 600-DC2815A
8	0	R10, R11, R13, R14, R19	RES., OPTION, 0402	
1	0	C14, C15	CAP., OPTION, 1210	
Hardware: For Demo Board Only				
1	7	E1, E3, E5, E7, E9-E11	TEST POINT, TURRET, 0.094" MTG. HOLE, PCB 0.062" THK	MILL-MAX, 2501-2-00-80-00-00-07-0
2	4	E2, E4, E6, E8	CONN., BANANA JACK, FEMALE, THT, NON-INSULATED, SWAGE, 0.218"	KEYSTONE, 575-4
3	4	JP1-JP4	CONN., HDR, MALE, 1x3, 2mm, VERT, ST, THT	WURTH ELEKTRONIK, 62000311121
4	4	MP1-MP4	STANDOFF, NYLON, SNAP-ON, 0.375"	KEYSTONE, 8832
5	4	XJP1, XJP5-XJP7	CONN., SHUNT, FEMALE, 2-POS, 2mm	SAMTEC, 2SN-BK-G

SCHEMATIC DIAGRAM

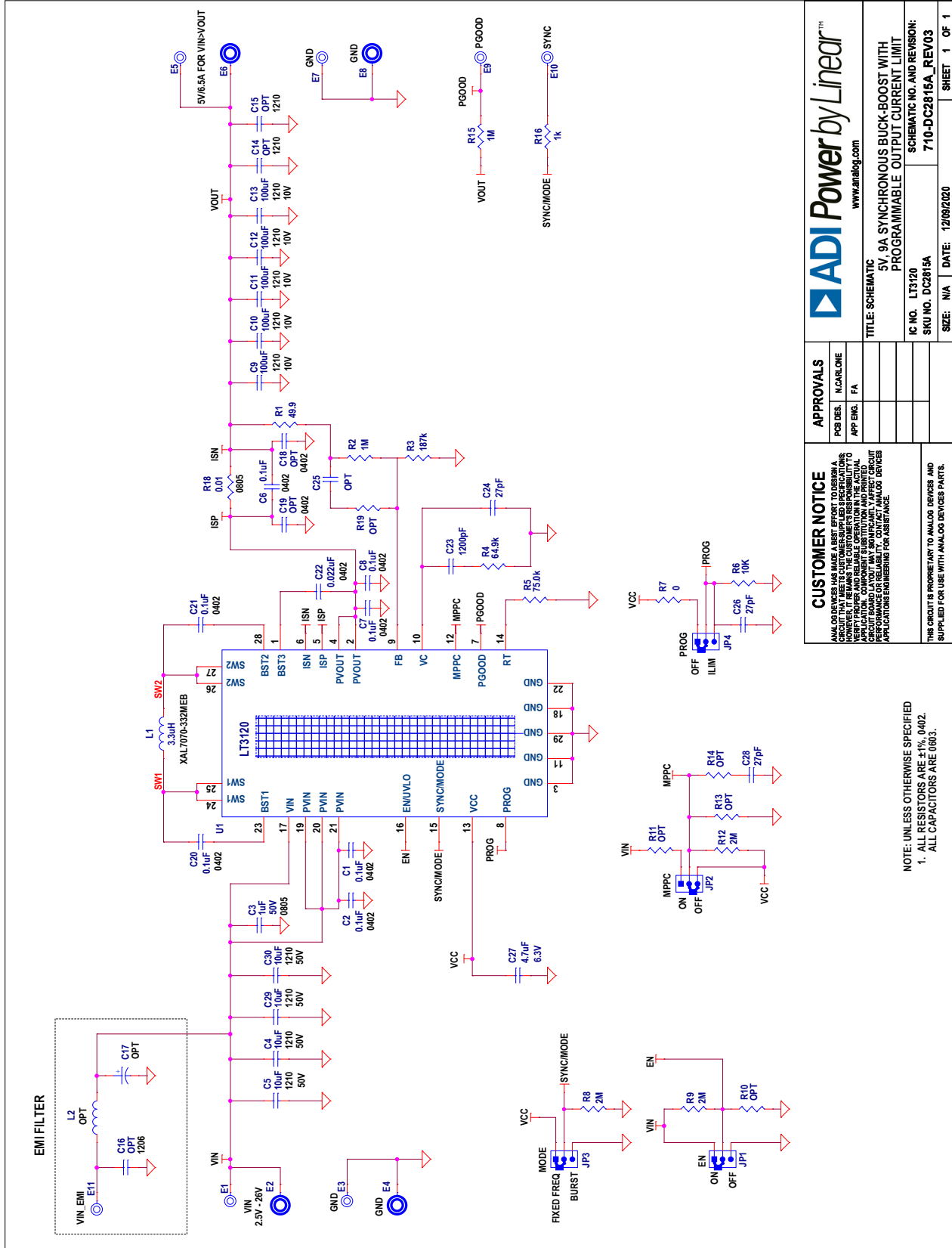

APPROVALS		ADI Power by Linear™ www.analog.com
PCB DES.	M. CARLONE	
APP ENG.	FA	TITLE: SCHEMATIC SV, 9A SYNCHRONOUS BUCK-BOOST WITH PROGRAMMABLE OUTPUT CURRENT LIMIT IC NO. LT13120 SKU NO. DC2815A SIZE: N/A DATE: 12/05/2020
CUSTOMER NOTICE ANALOG DEVICES ASSUMES NO LIABILITY FOR THE USE OF THIS SCHEMATIC IN ANY APPLICATION. HOWEVER, IT REMAINS THE CUSTOMER'S RESPONSIBILITY TO VERIFY THE SCHEMATIC'S PERFORMANCE IN THEIR APPLICATION. COMPONENT SUBSTITUTION AND DRIVEN PERFORMANCE IS NOT GUARANTEED. CONTACT ANALOG DEVICES APPLICATION ENGINEERING FOR ASSISTANCE.		
THIS CIRCUIT IS PROPRIETARY TO ANALOG DEVICES AND SUPPLIED FOR USE WITH ANALOG DEVICES PARTS.		SCHEMATIC NO. AND REVISION: 710-DC2815A_REV03 SHEET 1 OF 1

NOTE: UNLESS OTHERWISE SPECIFIED
 1. ALL RESISTORS ARE ±1%, 0402.
 ALL CAPACITORS ARE 0805.



ESD Caution

ESD (electrostatic discharge) sensitive device. Charged devices and circuit boards can discharge without detection. Although this product features patented or proprietary protection circuitry, damage may occur on devices subjected to high energy ESD. Therefore, proper ESD precautions should be taken to avoid performance degradation or loss of functionality.

Legal Terms and Conditions

By using the evaluation board discussed herein (together with any tools, components documentation or support materials, the "Evaluation Board"), you are agreeing to be bound by the terms and conditions set forth below ("Agreement") unless you have purchased the Evaluation Board, in which case the Analog Devices Standard Terms and Conditions of Sale shall govern. Do not use the Evaluation Board until you have read and agreed to the Agreement. Your use of the Evaluation Board shall signify your acceptance of the Agreement. This Agreement is made by and between you ("Customer") and Analog Devices, Inc. ("ADI"), with its principal place of business at One Technology Way, Norwood, MA 02062, USA. Subject to the terms and conditions of the Agreement, ADI hereby grants to Customer a free, limited, personal, temporary, non-exclusive, non-sublicensable, non-transferable license to use the Evaluation Board FOR EVALUATION PURPOSES ONLY. Customer understands and agrees that the Evaluation Board is provided for the sole and exclusive purpose referenced above, and agrees not to use the Evaluation Board for any other purpose. Furthermore, the license granted is expressly made subject to the following additional limitations: Customer shall not (i) rent, lease, display, sell, transfer, assign, sublicense, or distribute the Evaluation Board; and (ii) permit any Third Party to access the Evaluation Board. As used herein, the term "Third Party" includes any entity other than ADI, Customer, their employees, affiliates and in-house consultants. The Evaluation Board is NOT sold to Customer; all rights not expressly granted herein, including ownership of the Evaluation Board, are reserved by ADI. CONFIDENTIALITY. This Agreement and the Evaluation Board shall all be considered the confidential and proprietary information of ADI. Customer may not disclose or transfer any portion of the Evaluation Board to any other party for any reason. Upon discontinuation of use of the Evaluation Board or termination of this Agreement, Customer agrees to promptly return the Evaluation Board to ADI. ADDITIONAL RESTRICTIONS. Customer may not disassemble, decompile or reverse engineer chips on the Evaluation Board. Customer shall inform ADI of any occurred damages or any modifications or alterations it makes to the Evaluation Board, including but not limited to soldering or any other activity that affects the material content of the Evaluation Board. Modifications to the Evaluation Board must comply with applicable law, including but not limited to the RoHS Directive. TERMINATION. ADI may terminate this Agreement at any time upon giving written notice to Customer. Customer agrees to return to ADI the Evaluation Board at that time. LIMITATION OF LIABILITY. THE EVALUATION BOARD PROVIDED HEREUNDER IS PROVIDED "AS IS" AND ADI MAKES NO WARRANTIES OR REPRESENTATIONS OF ANY KIND WITH RESPECT TO IT. ADI SPECIFICALLY DISCLAIMS ANY REPRESENTATIONS, ENDORSEMENTS, GUARANTEES, OR WARRANTIES, EXPRESS OR IMPLIED, RELATED TO THE EVALUATION BOARD INCLUDING, BUT NOT LIMITED TO, THE IMPLIED WARRANTY OF MERCHANTABILITY, TITLE, FITNESS FOR A PARTICULAR PURPOSE OR NON-INFRINGEMENT OF INTELLECTUAL PROPERTY RIGHTS. IN NO EVENT WILL ADI AND ITS LICENSORS BE LIABLE FOR ANY INCIDENTAL, SPECIAL, INDIRECT, OR CONSEQUENTIAL DAMAGES RESULTING FROM CUSTOMER'S POSSESSION OR USE OF THE EVALUATION BOARD, INCLUDING BUT NOT LIMITED TO LOST PROFITS, DELAY COSTS, LABOR COSTS OR LOSS OF GOODWILL. ADI'S TOTAL LIABILITY FROM ANY AND ALL CAUSES SHALL BE LIMITED TO THE AMOUNT OF ONE HUNDRED US DOLLARS (\$100.00). EXPORT. Customer agrees that it will not directly or indirectly export the Evaluation Board to another country, and that it will comply with all applicable United States federal laws and regulations relating to exports. GOVERNING LAW. This Agreement shall be governed by and construed in accordance with the substantive laws of the Commonwealth of Massachusetts (excluding conflict of law rules). Any legal action regarding this Agreement will be heard in the state or federal courts having jurisdiction in Suffolk County, Massachusetts, and Customer hereby submits to the personal jurisdiction and venue of such courts. The United Nations Convention on Contracts for the International Sale of Goods shall not apply to this Agreement and is expressly disclaimed.

Mouser Electronics

Authorized Distributor

Click to View Pricing, Inventory, Delivery & Lifecycle Information:

[Analog Devices Inc.:](#)

[DC2815A](#)