

MAXIM

MAX1790 Evaluation Kit

Evaluates: MAX1790

General Description

The MAX1790 evaluation kit (EV kit) is a fully assembled and tested surface-mount circuit board that contains a fixed-frequency, pulse-width-modulated (PWM), step-up DC-DC converter. The EV kit provides a +5V output voltage from an input as low as +2.6V. It delivers up to 500mA output current. The MAX1790 features an internal MOSFET switch, programmable soft-start, and fast transient response.

The MAX1790 EV kit provides low quiescent current and high efficiency for maximum battery life. Operation at 640kHz allows the use of a tiny surface-mount inductor.

Component List

DESIGNATION	QTY	DESCRIPTION
C1	1	33 μ F, 10V, low-ESR electrolytic cap (POSCAP) Sanyo 10TPA33M
C2	1	47 μ F, 6.3V, low-ESR electrolytic cap (POSCAP) Sanyo 6TPA47M
C3	1	0.033 μ F ceramic capacitor (1206)
C4	1	820pF ceramic capacitor (1206)
C5	1	0.22 μ F ceramic capacitor (1206)
C6	1	56pF ceramic capacitor (0805)
C7	1	0.1 μ F ceramic capacitor (0805)
L1	1	5.4 μ H, 1.6A inductor Sumida CDRH5D18-5R4NC or Sumitomo CXLM120-5R6
D1	1	1A Schottky diode Nihon EP10QY03 or Toshiba CRS02
JU1	1	3-pin header
R1	1	1M Ω \pm 1% resistor (1206)
R2	1	324k Ω \pm 1% resistor (1206)
R3	1	62k Ω \pm 5% resistor (1206)
U1	1	MAX1790EUA (8-pin μ MAX)
None	1	Shunt
None	1	MAX1790 PC board
None	1	MAX1790 EV kit data sheet
None	1	MAX1790 data sheet

Features

- ◆ +2.6V to +5V Input Voltage Range
- ◆ 5V Output Voltage
- ◆ Up to 500mA Output Current
- ◆ 640kHz Fixed-Frequency PWM Operation
- ◆ Internal MOSFET Switch
- ◆ 0.1 μ A IC Shutdown Current
- ◆ Surface-Mount Components
- ◆ Fully Assembled and Tested

Ordering Information

PART	TEMP. RANGE	IC PACKAGE
MAX1790EVKIT	0°C to +70°C	8 μ MAX

Component Suppliers

SUPPLIER	PHONE	FAX
Coilcraft	708-639-6400	708-639-1469
Nihon	847-843-7500	847-843-2798
Sumida	408-982-9660	408-982-9858
Sumitomo	81-3-5952-8533	81-3-5952-8690
Toshiba	949-455-2000	949-859-3963
Zetex	516-543-7100	516-864-7630

Note: Please indicate that you are using the MAX1790 when contacting these component suppliers.

Quick Start

The MAX1790 EV kit is fully assembled and tested. Follow these steps to verify board operation. **Do not turn on the power supply until all connections are completed.**

- 1) Connect a +2.6V to +5V supply to the VIN pad. Connect ground to the GND pad.
- 2) Connect a voltmeter to the VOUT pad.
- 3) Verify that the shunt is across JU1 pins 1 and 2 to enable the MAX1790.
- 4) Turn on the power supply and verify that the output is at +5V.

MAX1790 Evaluation Kit

Detailed Description

Shutdown Mode

The EV kit features a shutdown mode that reduces the MAX1790 quiescent current to 0.1µA, preserving battery life. The three-pin header, JU1, selects the shutdown mode (Table 1).

Evaluating Other Output Voltages

The EV kit output is programmed to 5V. However, the output voltage can also be adjusted from V_{IN} to 12V by selecting R1 and R2 values. R2 can have a value up to 500kΩ without sacrificing accuracy. R1 is then given by:

$$R1 = R2 [(V_{OUT} / V_{FB}) - 1]$$

where $V_{FB} = 1.24V$.

Refer to the *Application Circuits* section of the MAX1790 data sheet for different output voltage circuits.

Switching Frequency Selection

The MAX1790 is shipped to operate at 640kHz. The switching frequency can be changed to 1.2MHz by installing jumper JU2 (Table 2). Refer to the MAX1790 data sheet for selecting the proper components to operate at 1.2MHz.

Table 1. Jumper JU1 Functions

SHUNT LOCATION	$\overline{\text{SHDN}}$ PIN	MAX1790 OUTPUT
1-2	Connected to V_{IN}	MAX1790 enabled, $V_{OUT} = +5V$
2-3	Connected to GND	Shutdown mode, $V_{OUT} = V_{IN} - V_{DIODE}$

Table 2. Frequency Pin Setting

SHUNT LOCATION	FREQUENCY PIN	SWITCHING FREQUENCY
Installed	Connected to V_{IN}	1.2MHz
Not installed	Floating	640kHz

MAX1790 Evaluation Kit

Evaluates: MAX1790

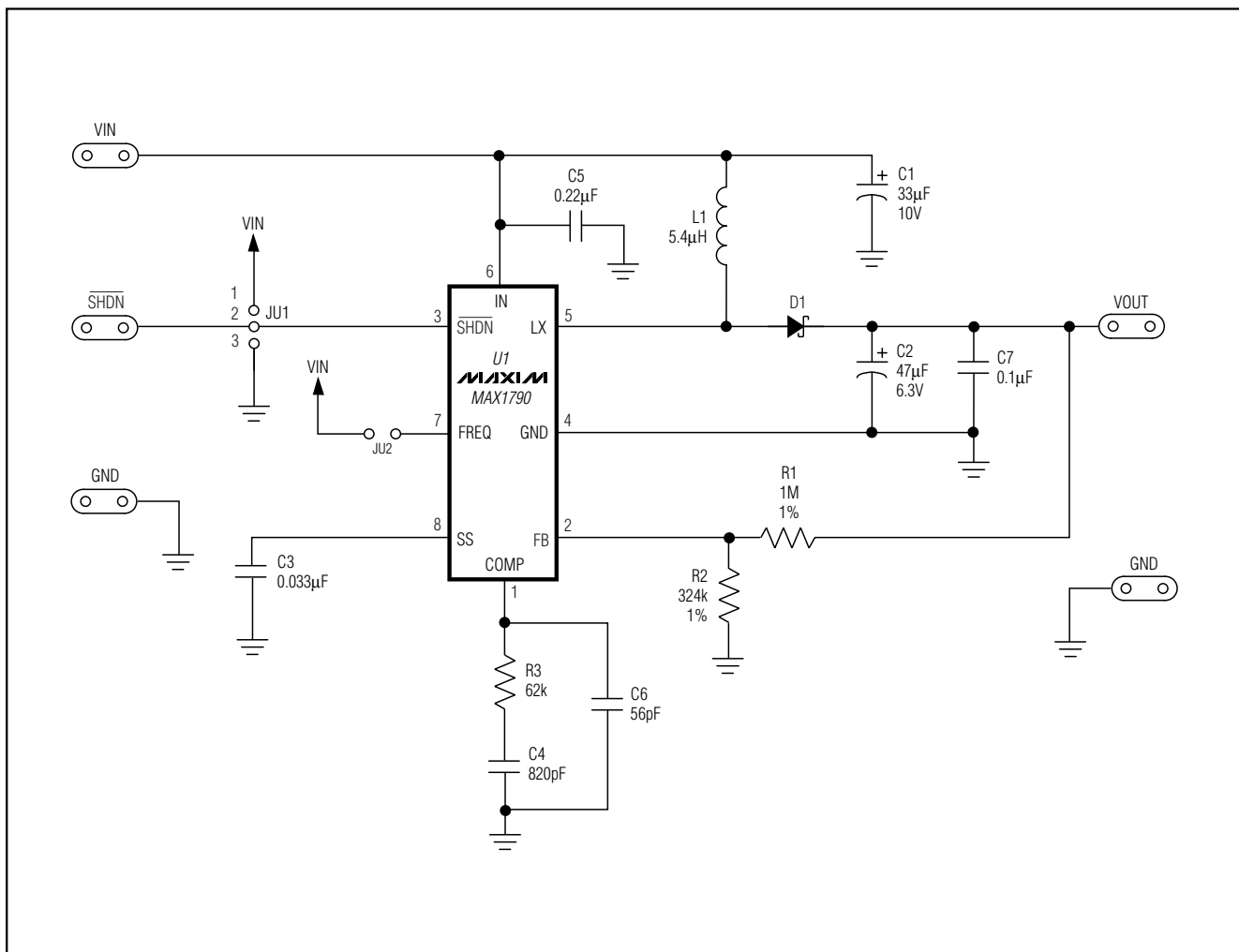

Figure 1. MAX1790 EV Kit Schematic

MAX1790 Evaluation Kit

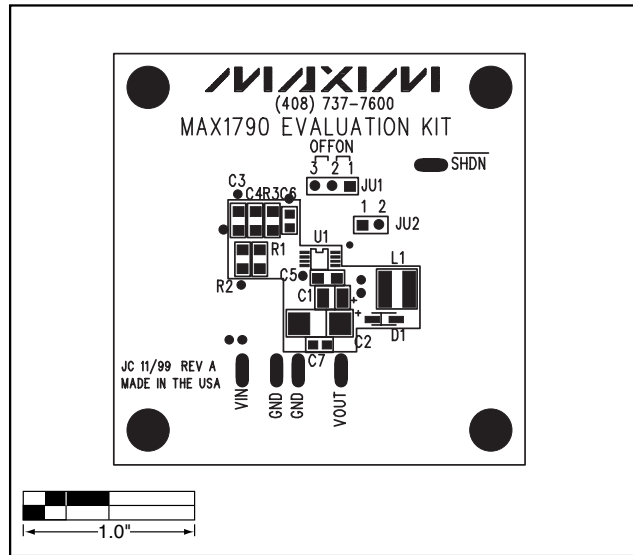

Figure 2. MAX1790 EV Kit Component Placement Guide—Component Side

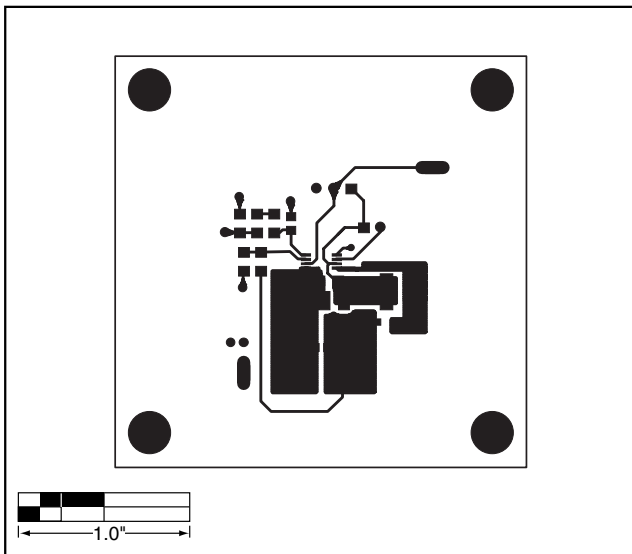

Figure 3. MAX1790 EV Kit PC Board Layout—Component Side

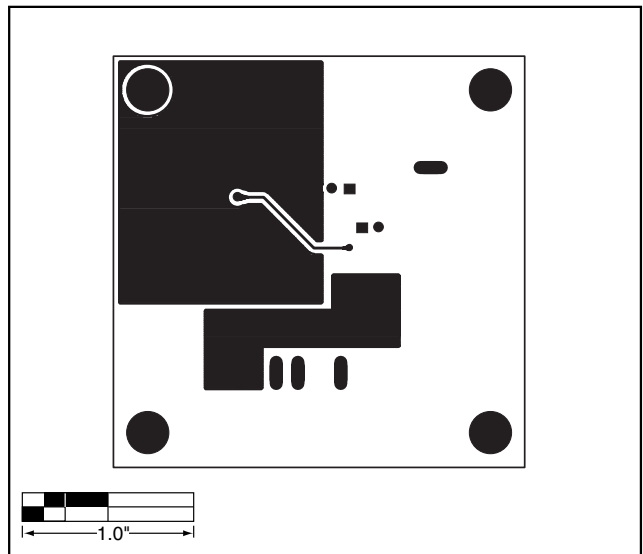

Figure 4. MAX1790 EV Kit PC Board Layout—Solder Side

Maxim cannot assume responsibility for use of any circuitry other than circuitry entirely embodied in a Maxim product. No circuit patent licenses are implied. Maxim reserves the right to change the circuitry and specifications without notice at any time.

4 _____ **Maxim Integrated Products, 120 San Gabriel Drive, Sunnyvale, CA 94086 408-737-7600**

Mouser Electronics

Authorized Distributor

Click to View Pricing, Inventory, Delivery & Lifecycle Information:

[Analog Devices Inc.:](#)

[MAX1790EVKIT](#)