

LTC4054-4.2 Li-Ion Battery Charger in SOT-23

DESCRIPTION

Demonstration circuit 569 is a single cell Li-Ion linear charger in a SOT-23. Charge rates as high as 600mA can be achieved due to the LTC[®]4054's internal die temperature control loop that prevents excessive PCB heating under worst-case conditions. The user is provided with a control jumper to select between OFF/450mA/600mA charge rates.

The reduced charge rate is suitable for USB applications. A charge LED illuminates while the charger is charging the battery.

Design files for this circuit board are available at <http://www.linear.com/demo/DC569B>

LT, LT, LTC, LTM, Linear Technology and the Linear logo are registered trademarks of Linear Technology Corporation. All other trademarks are the property of their respective owners.

PERFORMANCE SUMMARY Specifications are at T_A = 25°C

PARAMETER	CONDITIONS	VALUE
I _{OUT}	450mA Selected V _{BAT} = 3.6V	450mA ±7%
I _{OUT}	600mA Selected V _{BAT} = 3.6V	600mA ±7%
Float Voltage	V _{IN} = 5V	4.20V ±1%
Trickle Charge Threshold	V _{IN} = 5V	2.9V ±0.1V
C/10 Detection	V _{IN} = 5V, V _{BAT} = 4.2	C/9–C/11
Recharge Threshold	V _{IN} = 5V	4.05V + –50mV

OPERATING PRINCIPLES

Demonstration circuit 569 is a simple single cell Li-Ion charger. The demo features the LTC4054-4.2 charger IC. This charger implements a constant die temperature, constant current, and constant voltage charge scheme. Charge termination occurs when the charge rate falls to beneath 10% of the programmed charge current. A topping charge will be applied if the cell voltage falls to 4.05V to insure long-term charge maintenance. Deeply discharged cells are conditioned with a low C/10 trickle current until the

cell voltage reaches 2.9V whereupon full charge current is applied. In the event that full charge current would result in excessive dissipation a die temperature control loop backs off the charge current to maintain a reasonable PC board temperature. A charge LED is provided that illuminates every time the charger is charging the battery. The peak charge current is jumper selectable at either 600mA or 450mA. The 450mA rate is intended for USB applications.

QUICK START PROCEDURE

Demonstration circuit 569 is easy to set up to evaluate the performance of the LTC4054-4.2. Refer to Figure 1 for proper measurement equipment setup and follow the procedure below:

1. Use the jumper provided to select the desired charge rate 450mA or 600mA.
2. With the power off, connect the input power supply to V_{IN} and GND.
3. Connect the demo board to the battery simulator as shown in Figure 1.
4. Set the battery simulator voltage to zero and then slowly raise the input voltage.

When the supply voltage exceeds 4.25V, the charger should activate and the charge LED will illuminate.

5. Note that, so long as the battery voltage is under the Trickle Charge threshold of 2.9V, the charge current is 10% of the selected charge current.
6. Increase the battery voltage to about 3V and note that the charge current has increased beyond the trickle charge current.
7. Heat up the LTC4054 by touching a soldering iron to the PCB.

Verify that the LTC4054-4.2 thermal loop is working—the charge current should decrease. Remove the iron and the charge current increases. This demonstrates the “constant die temperature” operating mode.

8. Continue to increase the battery voltage. Note that as the voltage drop across the LTC4054 decreases, the constant die temperature loop is no longer active and the charge current is the programmed charge current.
9. Continue to increase the battery voltage; as the battery voltage approaches the float voltage of 4.2V, the charge current begins to drop. Note that as the charge current drops to 10% of the programmed current, the charger terminates. Charge current falls to zero and the charge LED extinguishes.
10. Slowly decrease the battery voltage to simulate a long term self-discharge of the battery. Note, that as the battery voltage drops to 4.05V, that another charge cycle is initiated.
11. Place the charge rate selector in the OFF position. Note that the battery current draw is extremely low (approx $1\mu\text{A}$). Also note that the supply current draw is low (approx $20\mu\text{A}$).

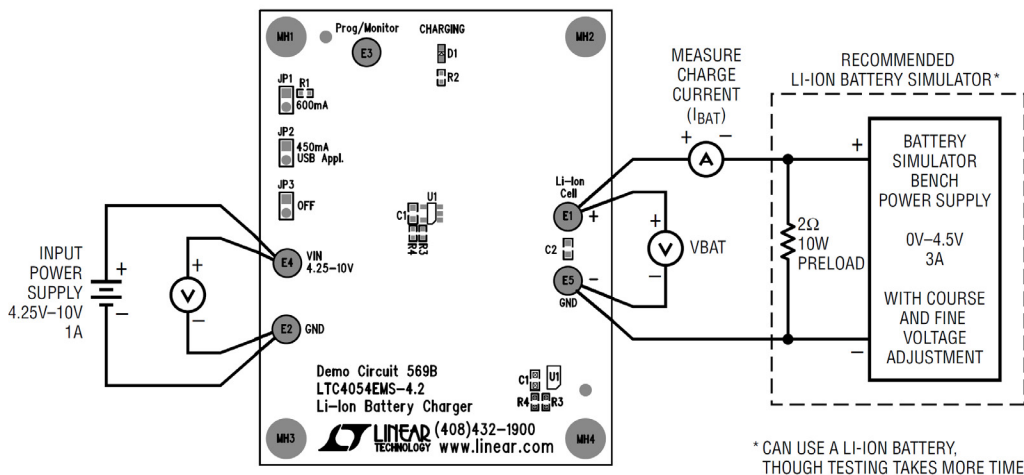

Figure 1. Proper Measurement Equipment Setup

USB APPLICATIONS

USB battery chargers based on the LTC4054-4.2 can be created in a variety of ways. One way is to place the USB load parallel to the battery. The advantage to this scheme is that no special measures must be taken with the load in order to gain USB compliance. The disadvantage to this scheme is that all USB power flows through the LTC4054, so some of the USB power is inevitably dissipated in the LTC4054. Additional load current registers as battery current and could potentially disrupt the C/10 termination scheme.

The preferred technique for USB charger applications is to use the LTC4410 USB power manager IC available on demonstration circuit 567.

The problem is that DC567 combines the LTC4410 and the LTC4053 in a complete USB compliant charging solution. Nevertheless, it is not difficult to disconnect the LTC4053 on DC567 and instead hook up the LTC4054 from DC569.

Combining DC567 and DC569 to Create a USB-Compliant Charger

1. On DC567, separate the LTC4053 from the LTC4410 by using an X-Acto knife to cut through the four traces connecting the two halves of the demo board.
2. Connect DC567 and DC569 together as follows.
 - a. GND of DC567 to GND of DC569
 - b. V_{IN} of DC567 to V_{IN} of DC569
 - c. CHP/Monitor pin of DC567 to Prog/Monitor pin of DC569
 - d. From the battery terminal of DC567 to the battery terminal of DC569

This creates a USB compliant battery charger.

Testing the USB-Compliant Charger

1. Hook up an adjustable load (0mA to 500mA) to the USB device terminal of the DC567.
2. Hook up the USB input supply 5V, 500mA to the V_{IN} terminal of either demo board.
3. Hook up the simulated battery as previously described or an actual battery to the battery terminal of DC569.
4. Place the charge current jumper of DC569 in the 450mA USB Appl. position.
5. Simulate the USB low power mode by placing the mode jumper on DC567 in the 100mA position.
6. Turn on the input supply.
7. Set the simulated battery to some nominal voltage, typically 3.6V.
8. Set the load of the USB device to 0mA.
9. Note the charge current to the battery and the input current.
10. Now increase the USB load current, note that the battery current decreases and the input current remains constant and below 100mA
11. Simulate the USB high power mode by placing the mode jumper on DC567 in the 500mA position and repeating steps 8 to 10. The input current remains below 500mA
12. Simulate the USB suspend mode by setting the mode jumper on DC567 in the 500mA position and by removing the charge current jumper from DC569. Note the input current is below 100 μ A.

DEMO MANUAL DC569B

USB APPLICATIONS

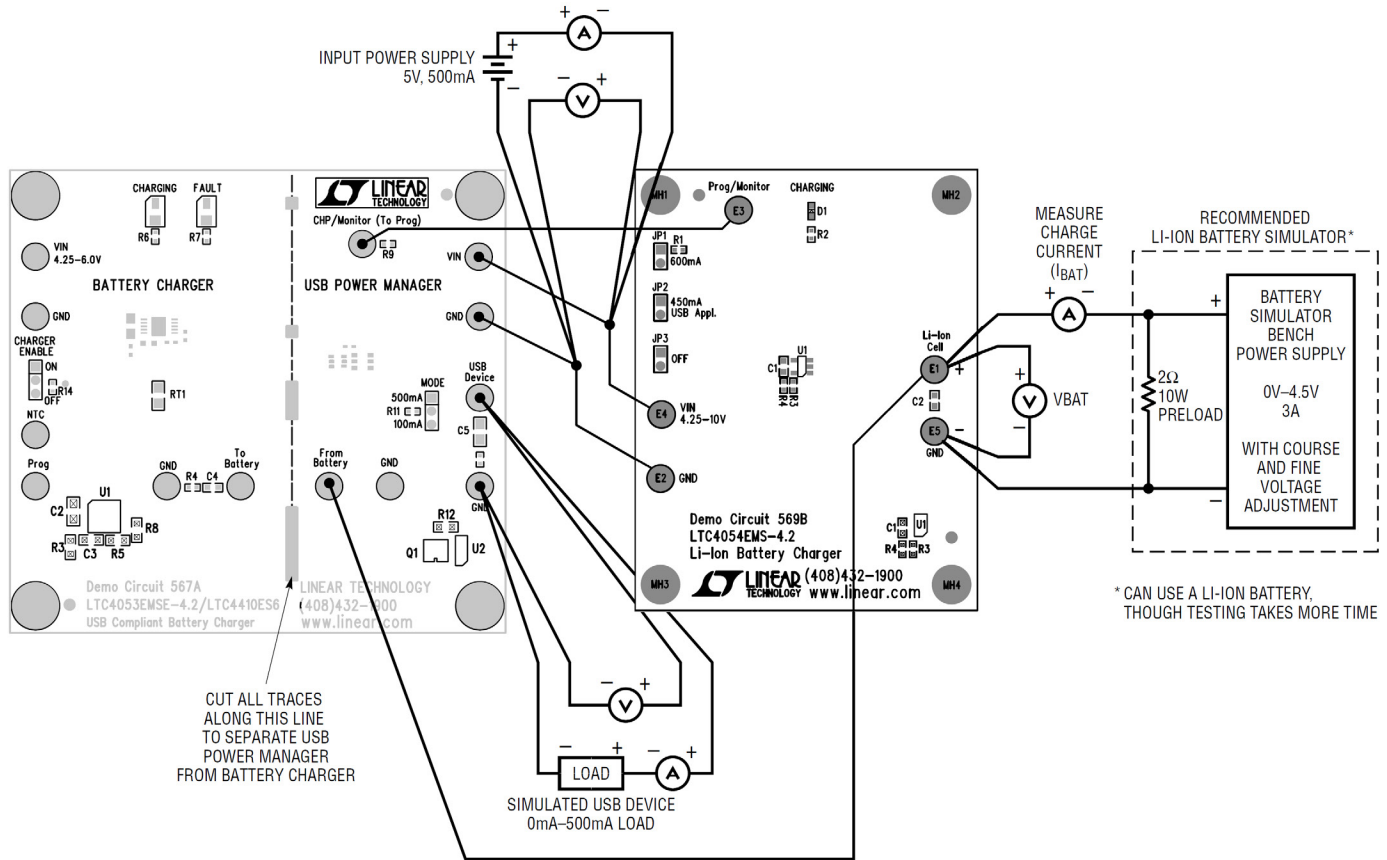

Figure 2. Combining DC567 and DC569 to Create a USB-Compliant Charger

PARTS LIST

ITEM	QTY	REFERENCE	PART DESCRIPTION	MANUFACTURER/PART NUMBER
Required Circuit Components				
1	2	C1, C2	CAP, 1μF, X5R, 10V, 20%, 0603	AVX, 0603ZD105MAT2A
2	1	R1	RES., 1.62kΩ, 1%, 1/16W, 0402	VISHAY, CRCW04021K62FKED
3	1	R4	RES., 1Ω, 5%, 1/16W, 0402	VISHAY, CRCW04021R00JNED
4	1	U1	IC, LI-ON BATTERY CHARGER, TSOT23-5	LINEAR TECHNOLOGY, LTC4054ES5-4.2#PBF
Additional Demo Board Circuit Components				
1	1	D1	LED, GREEN, MILKY WHITE DIFF, 0603 SMD	LUMEX, SML-LX0603GW-TR
2	1	R2	RES., 1kΩ, 5%, 1/16W, 0402	VISHAY, CRCW04021K00JNED
3	1	R3	RES., 2.21kΩ, 1%, 1/16W, 0402	VISHAY, CRCW04022K21FKED
Hardware: For Demo Board Only				
1	4	MH1, MH2, MH3, MH4	STANDOFF, NYLON, SNAP-ON, 0.250"	KEYSTONE, 8831
2	5	TP1, TP2, TP3, TP4, TP5	TEST POINT, TURRET, 0.094", MTG. HOLE	MILL-MAX, 2501-2-00-80-00-00-07-0
3	3	JP1, JP2, JP3	CONN., HDR., MALE, 1x2, 2mm, THT, STR	WURTH ELEKTRONIK, 62000211121
4	1	XJP2	CONN., SHUNT, FEMALE, 2 POS, 2mm	WURTH ELEKTRONIK, 60800213421

dc569bf

SCHEMATIC DIAGRAM

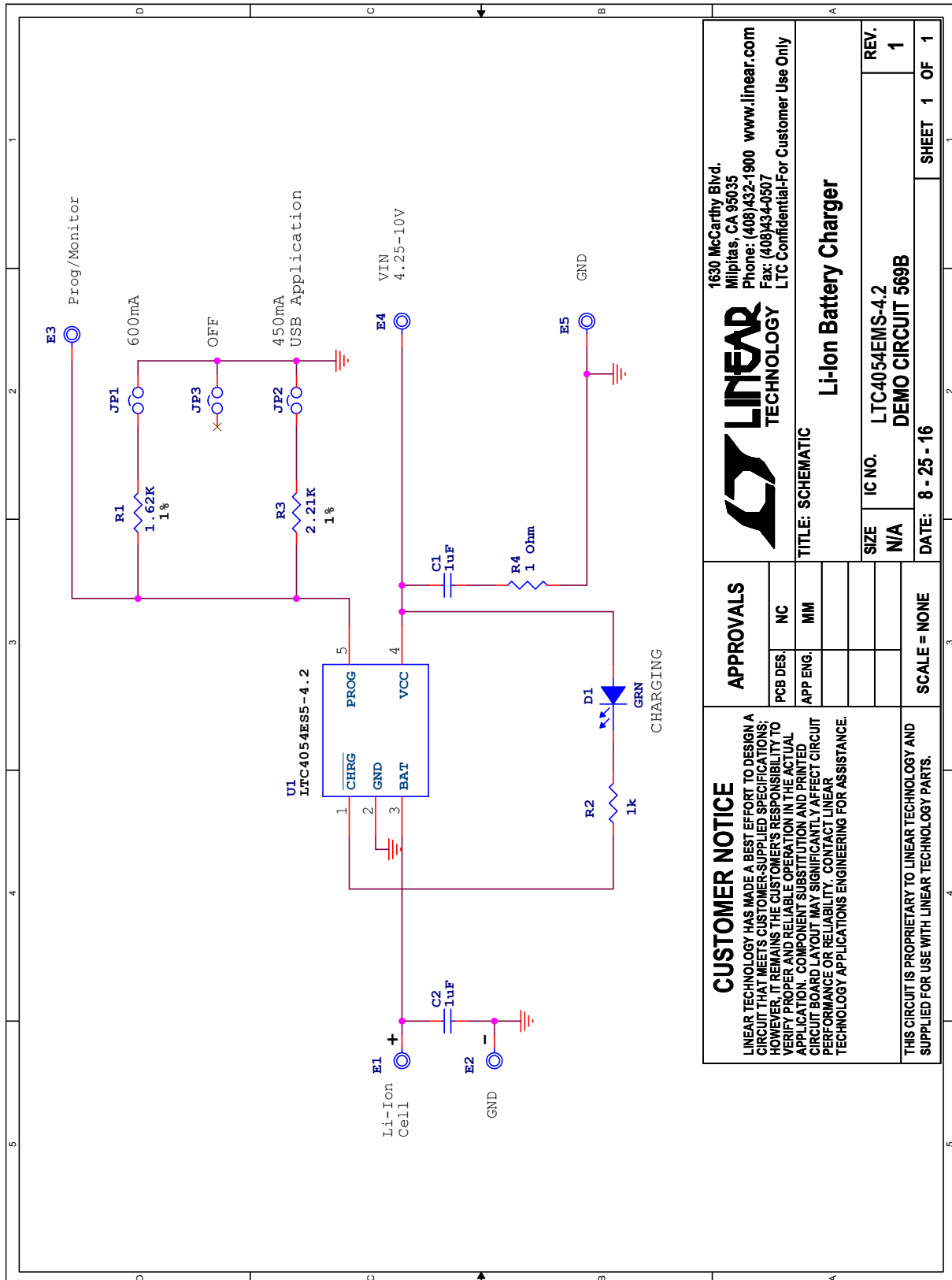

LINEAR TECHNOLOGY
 1630 McCarthy Blvd.
 Milpitas, CA 95035
 Phone: (408)432-1900 www.linear.com
 Fax: (408)434-0507
 LTC Confidential-For Customer Use Only

Li-Ion Battery Charger

IC NO. LTC4054EMS-4.2
 DEMO CIRCUIT 569B

REV. 1

SHEET 1 OF 1

APPROVALS	
PCB DES. NC	APP ENG. MM
SCALE = NONE	

CUSTOMER NOTICE
 LINEAR TECHNOLOGY HAS MADE A BEST EFFORT TO DESIGN A CIRCUIT THAT MEETS CUSTOMER-SUPPLIED SPECIFICATIONS; HOWEVER, IT REMAINS THE CUSTOMER'S RESPONSIBILITY TO VERIFY PROPER AND RELIABLE OPERATION IN THE ACTUAL APPLICATION. COMPONENT SUBSTITUTION AND PRINTED CIRCUIT BOARD LAYOUT MAY SIGNIFICANTLY AFFECT CIRCUIT PERFORMANCE OR RELIABILITY. CONTACT LINEAR TECHNOLOGY APPLICATIONS ENGINEERING FOR ASSISTANCE.

THIS CIRCUIT IS PROPRIETARY TO LINEAR TECHNOLOGY AND SUPPLIED FOR USE WITH LINEAR TECHNOLOGY PARTS.

DEMO MANUAL DC569B

DEMONSTRATION BOARD IMPORTANT NOTICE

Linear Technology Corporation (LTC) provides the enclosed product(s) under the following **AS IS** conditions:

This demonstration board (DEMO BOARD) kit being sold or provided by Linear Technology is intended for use for **ENGINEERING DEVELOPMENT OR EVALUATION PURPOSES ONLY** and is not provided by LTC for commercial use. As such, the DEMO BOARD herein may not be complete in terms of required design-, marketing-, and/or manufacturing-related protective considerations, including but not limited to product safety measures typically found in finished commercial goods. As a prototype, this product does not fall within the scope of the European Union directive on electromagnetic compatibility and therefore may or may not meet the technical requirements of the directive, or other regulations.

If this evaluation kit does not meet the specifications recited in the DEMO BOARD manual the kit may be returned within 30 days from the date of delivery for a full refund. **THE FOREGOING WARRANTY IS THE EXCLUSIVE WARRANTY MADE BY THE SELLER TO BUYER AND IS IN LIEU OF ALL OTHER WARRANTIES, EXPRESSED, IMPLIED, OR STATUTORY, INCLUDING ANY WARRANTY OF MERCHANTABILITY OR FITNESS FOR ANY PARTICULAR PURPOSE. EXCEPT TO THE EXTENT OF THIS INDEMNITY, NEITHER PARTY SHALL BE LIABLE TO THE OTHER FOR ANY INDIRECT, SPECIAL, INCIDENTAL, OR CONSEQUENTIAL DAMAGES.**

The user assumes all responsibility and liability for proper and safe handling of the goods. Further, the user releases LTC from all claims arising from the handling or use of the goods. Due to the open construction of the product, it is the user's responsibility to take any and all appropriate precautions with regard to electrostatic discharge. Also be aware that the products herein may not be regulatory compliant or agency certified (FCC, UL, CE, etc.).

No License is granted under any patent right or other intellectual property whatsoever. **LTC assumes no liability for applications assistance, customer product design, software performance, or infringement of patents or any other intellectual property rights of any kind.**

LTC currently services a variety of customers for products around the world, and therefore this transaction **is not exclusive**.

Please read the DEMO BOARD manual prior to handling the product. Persons handling this product must have electronics training and observe good laboratory practice standards. **Common sense is encouraged.**

This notice contains important safety information about temperatures and voltages. For further safety concerns, please contact a LTC application engineer.

Mailing Address:

Linear Technology
1630 McCarthy Blvd.
Milpitas, CA 95035

Copyright © 2004, Linear Technology Corporation

Mouser Electronics

Authorized Distributor

Click to View Pricing, Inventory, Delivery & Lifecycle Information:

[Analog Devices Inc.:](#)

[DC569B](#)