

### FEATURES

- Complete RTD Signal Conditioning Solution
- Resistor Programmable Linearization
- Lead Resistance Compensation
- High CMV Isolation: 1500 V rms Continuous
- High Accuracy
  - Low Input Offset Tempco:  $0.002 \Omega/^\circ\text{C}$
  - Linearization Conformance:  $\pm 0.1\%$  FSR
  - High CMR: 160 dB (60 Hz,  $G = 1000 \text{ V/V}$ )
- Small Package:  $1.0" \times 2.1" \times 0.35"$  DIP
- Low Pass Filter ( $f_c = 3 \text{ Hz}$ )
- Pin Compatible with 1B51 Isolated mV/Thermocouple Conditioner

### APPLICATIONS

- Multichannel RTD Temperature Measurement
- Industrial Measurement and Control Systems
- Data Acquisition Systems

### GENERAL DESCRIPTION

The 1B41 is a precision, isolated, RTD signal conditioner that incorporates a circuit design utilizing transformer based isolation and automated surface mount manufacturing technology. It provides an unbeatable combination of versatility and performance in a compact plastic package. Designed for measurement and control applications, it is especially suited for harsh environments with extremely high common mode interference. Unlike expensive solutions that require separate dc/dc converters, each 1B41 generates its own floating current excitation, providing true low cost channel-to-channel isolation.

Functionally, the signal conditioner consists of four basic sections: chopper stabilized amplifier, isolation, current excitation and output filter. The amplifier section allows an RTD resistance range of  $20 \Omega$  to  $5 \text{ k}\Omega$ . Wide range zero suppression can be implemented at this stage.

The isolation section has complete input to output galvanic isolation of 1500 V rms continuous by the use of transformer coupling techniques. A stable sensor excitation provides 0.25 mA for most RTD applications. For platinum RTDs the excitation is internally compensated to provide an output that is linear with temperature. Filtering at 3 Hz is implemented by a passive antialiasing filter at the input and a two-pole active filter at the output. Overall NMR is 60 dB and CMR is 160 dB min @ 60 Hz.

The 1B41 is fully specified over  $-25^\circ\text{C}$  to  $+85^\circ\text{C}$  and operates over the industrial ( $-40^\circ\text{C}$  to  $+85^\circ\text{C}$ ) temperature range.

### FUNCTIONAL BLOCK DIAGRAM

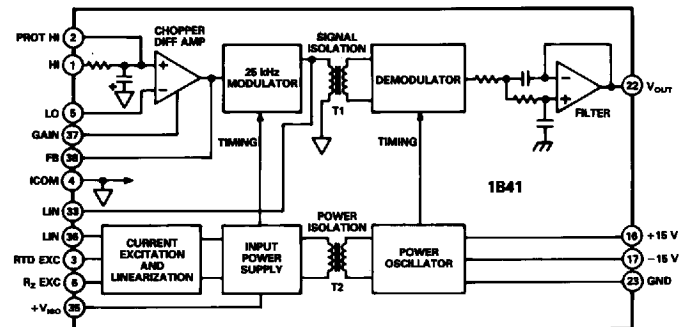

### DESIGN FEATURES AND USER BENEFITS

**Ease of Use:** The 1B41 has direct RTD interface with minimum external parts required to get a high-level, conditioned signal.

**Lead Resistance Compensation:** Voltage drops in RTD lead wires are compensated by the use of matching current sources in the 1B41.

**High Noise Rejection:** The combination of a chopper stabilized front end with a low pass filter provides high system accuracy in harsh industrial environments as well as good rejection of 50/60 Hz noise.

**Small Size:** The 1B41 package size ( $1.00" \times 2.1" \times 0.35"$ ) and functional completeness makes it an excellent choice in systems with limited board space and clearance.

**Wide Range Zero Suppression:** This input referred function is a convenient way to null large input offsets. A single resistor value sets the RTD resistance for which the output is zero volts.

**Low Pass Filter:** The three-pole active filter ( $f_c = 3 \text{ Hz}$ ) reduces 50/60 Hz noise and aliasing errors.

# 1B41—SPECIFICATIONS (typical @ +25°C and $V_s = +15$ V unless otherwise noted)

Model	1B41AN	1B41BN
<b>INPUT SPECIFICATIONS</b>		
Sensor Type	Pt 100 $\Omega$ @ 0°C, $\alpha = 0.00385, 0.00392$	*
Linear Input Resistance Range	20 $\Omega$ to 5 k $\Omega$ Full Scale	*
Max Input Voltage Range	+1 V to -5 V	*
Input Offset	0.5 $\Omega$ (2 $\Omega$ max)	*
Input Offset Tempo	0.002 $\Omega$ /°C (0.01 $\Omega$ /°C max)	*
Max CMV, Input to Output ac, 60 Hz, Continuous	1500 V rms	*
Continuous, dc	$\pm 2000$ V peak	*
CMR, @ 60 Hz, 1 k $\Omega$ Source Imbalance	160 dB min	*
NMR, @ 60 Hz	60 dB min	*
Common Mode Transient Protection	IEEE-STD 472 (SWC)	*
Sensor Current Excitation	0.25 mA	*
Current Source Matching	1.5 $\mu$ A	*
<b>OUTPUT SPECIFICATIONS</b>		
Voltage, 2 k $\Omega$ Load, min	$\pm 10$ V	*
Current	$\pm 5$ mA	*
Output Offset Voltage		
Initial	50 mV typ	25 mV typ
vs. Temperature	175 $\mu$ V/°C	50 $\mu$ V/°C
Output Noise, dc to 100 kHz	1 mV pk-pk	*
Impedance, dc	0.1 $\Omega$	*
<b>ACCURACY</b>		
Gain Accuracy <sup>2</sup>	2% FSR (5% FSR max)	*
Gain Tempo (0 to +70°C) (-25°C to +85°C)	$\pm 50$ ppm/°C	*
	$\pm 75$ ppm/°C	*
Gain Nonlinearity	$\pm 0.035\%$	$\pm 0.025\%$
Linearization Conformance		
Pt 100 $\Omega$	0.1% FSR	*
0 to +600°C	0.09% FSR	*
0 to +200°C	0.06% FSR	*
0 to +100°C	0.06% FSR	*
-100°C to +100°C	0.06% FSR	*
Lead Wire Compensation	0.01 $\Omega$ / $\Omega$	*
<b>DYNAMIC RESPONSE</b>		
Bandwidth, -3 dB	dc to 3 Hz	*
<b>POWER SUPPLY</b>		
Voltage, Rated Performance	$\pm 15$ V dc	*
Voltage, Operating	$\pm 13.5$ V to $\pm 18$ V	*
Current, Quiescent	+12 mA, -4 mA	*
<b>ENVIRONMENTAL</b>		
Temperature Range		
Rated Performance	-25°C to +85°C	*
Operating	-40°C to +85°C	*
Storage	-40°C to +85°C	*
Relative Humidity	0 to 95% @ 60°C	*
<b>CASE SIZE</b>		
	1.0" $\times$ 2.1" $\times$ 0.35" (25.4 $\times$ 53.3 $\times$ 8.9) mm	*

## NOTES

\*Specifications same as 1B41AN.

<sup>1</sup>All specifications use the test circuit of Figure 1.

<sup>2</sup>Excluding external ranging resistor errors.

Specifications subject to change without notice.

## OUTLINE DIMENSIONS

Dimensions shown in inches and (mm).

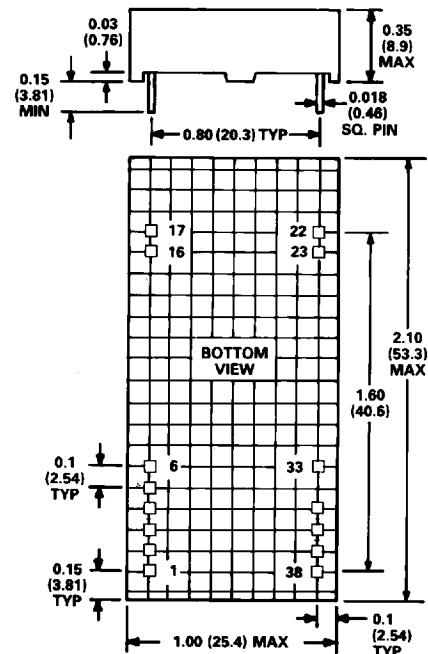

## AC 1227 MATING SOCKET

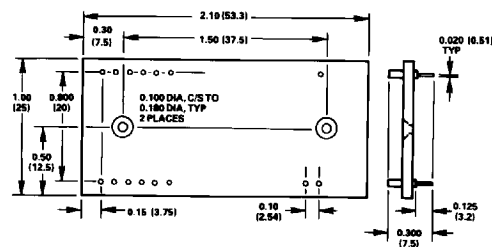

## PIN DESIGNATIONS

PIN	DESIGNATION
1	HI
2	PROT HI
3	RTD EXC
4	ICOM
5	LO
6	R <sub>Z</sub> EXC
16	+15 V
17	-15 V
22	V <sub>O</sub>
23	GND
33	LIN
35	+V <sub>ISO</sub>
36	LIN
37	GAIN
38	FB

**INSIDE THE 1B41**

Referring to the functional block diagram, the ±15 V power inputs provide power to both the output side circuitry and the power oscillator. The 25 kHz power oscillator provides both the timing information for the signal demodulator and drives transformer T2 for the input side power supplies. The secondary winding of T2 is half wave rectified and filtered to create the input side power.

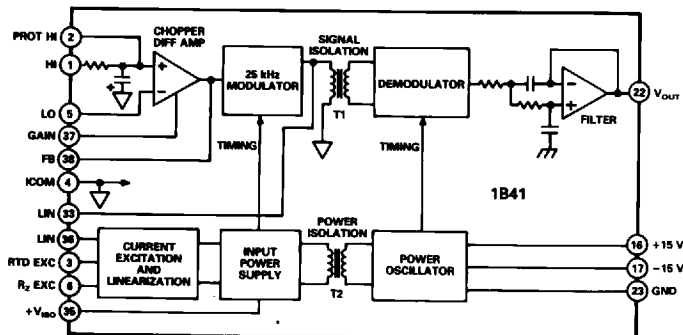

1B41 Functional Block Diagram

Dual current sources of 0.25 mA are derived from the floating power supply and accomplish 3-wire compensation as well. This creates a voltage difference between the RTD and  $R_Z$ . This voltage is applied to the chopper stabilized differential amplifier. Linearization can be implemented at this stage by a simple jumper option. This creates a bow in the current source that nulls out the nonlinearity of Pt 100 RTDs.

The signal input (HI) is single pole filtered for noise rejection and antialiasing. PROT HI is the output node of the filter, and is used only for special input applications as described in the applications section of this data sheet.

The chopper stabilized gain stage amplifies the differential input voltage with a gain set by external resistors.

The signal is amplitude modulated onto a 25 kHz carrier and passed through the signal transformer T1. The synchronous demodulator restores the signal to the baseband. A two-pole active low pass stage filters out clock noise and completes a three-pole Butterworth filter formed with the input pole.

**USING THE 1B41**

**Range Setting:** The gain of the 1B41 is controlled on the input side by a pair of user provided resistors (see Figure 1). A feedback resistor of 20 kΩ ±1% is required between the feedback pin (Pin 38) and the gain pin (Pin 37). The gain setting resistor is connected between the gain pin (Pin 37) and input side common (Pin 4).

In the equations below  $R_Z$  is the value of the RTD resistance at the temperature at which zero volts output is desired,  $R_{HS}$  is the resistance of the RTD when the temperature is the average of the zero output temperature and the full-scale temperature, and  $R_{FS}$  is the resistance of the RTD at the full-scale temperature.

$$R_G = 20 \text{ k}\Omega / (G - 1)$$

$$R_{LIN} = 6.1 \text{ k}\Omega (2Q - 3) / (2 - Q)$$

where  $Q = \Delta R_{FS} / \Delta R_{HS}$   
 $G = (20 \text{ k}\Omega / \Delta R_{FS}) (Q - 1)$   
 $\Delta R_{FS} = R_{FS} - R_Z$   
 $\Delta R_{HS} = R_{HS} - R_Z$

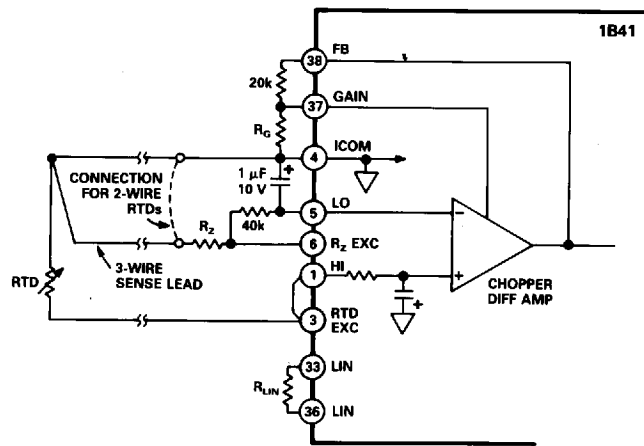

Figure 1. 1B41 Basic Hookup

Since gain and linearization are interactive, it is recommended that any offset and span errors be removed in software or at a later stage in the data acquisition circuitry.

The accuracy of the resistor values must be taken into account when calculating the initial gain accuracy of an application. The initial accuracy of the 1B41 must then be added to the resistor errors to predict the total accuracy. Likewise, the ratiometric temperature coefficient of the gain and feedback resistors must be added to the temperature coefficient of the 1B41 to predict the total resulting thermal drift.

**3-Wire Compensation:** The 1B41 accomplishes 3-wire compensation by using matched current sources on both RTD EXC (Pin 3) and  $R_Z$  EXC (Pin 6). Figure 2 shows lead wires with resistances of  $R_{L1}$ ,  $R_{L2}$  and  $R_{L3}$ . The following equation describes the error voltage caused by lead resistance and the current source mismatch.

$$V_{ERROR} = I_1 R_{L3} - I_2 R_{L2}$$

This equation depends upon the matching of the wire resistance and the matching of the 1B41 current sources. When all leads have the same resistance and the current sources are matched, no error is introduced.

For 2-wire RTDs, ICOM (Pin 4) can be connected as shown in Figure 1. This does not compensate for lead wire resistance.

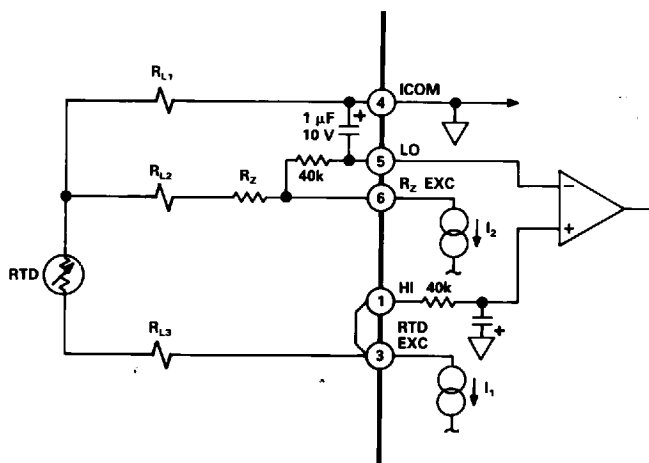

Figure 2. 3-Wire Compensation

# 1B41

Note that since the current sources are in fact *current sinks*, as the RTD resistance increases, the voltage at HI (Pin 1) gets more negative. This causes the output of the 1B41 to get more positive.

Example: A 100 Ω platinum RTD,  $\alpha = 0.00385$ , is 100 Ω at 0°C, 138.50 Ω at 100°C, and 175.84 Ω at 200°C.

$$R_Z = 100 \Omega, R_{HS} = 138.50 \Omega, R_{FS} = 175.84 \Omega$$

$$Q = \frac{175.84 - 100}{138.50 - 100} = 1.9699$$

$$R_{LIN} = \frac{6.1 \text{ k}\Omega(2 \times 1.9699 - 3)}{(2 - 1.9699)} = 190.46 \text{ k}\Omega$$

$$R_G = \frac{20 \text{ k}\Omega}{255.78 - 1} = 78.5 \Omega$$

## PERFORMANCE

**CMR and NMR:** Common mode rejection is a result of both isolation and filtering, and is dependent on signal frequency, conditioner gain and source impedance imbalance.

The CMR performance is also enhanced by low pass filtering, giving an effective CMR of 160 dB at 60 Hz ( $f_C = 3$  Hz) at the output of the filter.

**Gain Nonlinearity:** 1B41 gain nonlinearity is defined as the deviation of the output voltage from the best straight line and is specified as % peak-to-peak of a  $\pm 10$  V output span.

## APPLICATION EXAMPLES

**Input Protection:** Although the 1B41 provides  $\pm 1500$  V of common mode protection, it is sometimes desirable to have some level of normal mode protection as well. The signal input of the 1B41 is normally less than 500 mV but could be very large under a fault condition.

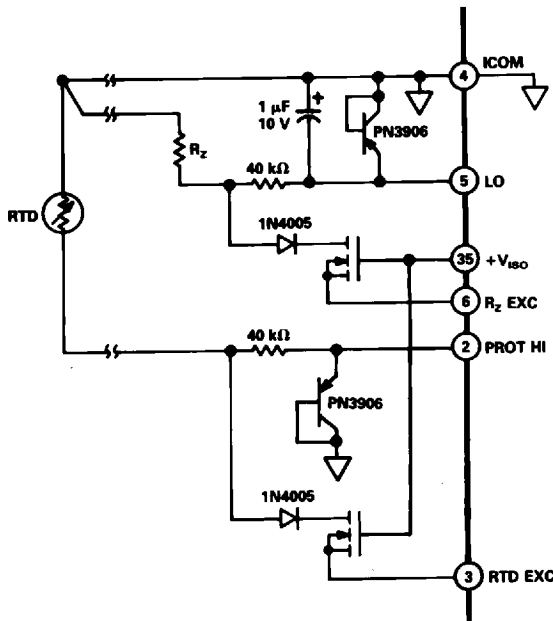

Figure 3. 120 V/240 V AC Normal Mode Input Protection

Referring to Figure 3, the inputs and current sources show 240 V rms protection. The PN3906 pnp transistors are used for the diode properties of the base emitter junction. When the emitter is more positive than the base, the transistor functions as a forward biased diode. When the emitter is negative with respect to the base, the junction is a very low leakage Zener diode with a breakdown voltage of about -8 V. This serves as a voltage clamp for LO and PROT HI. A fault voltage applied between ICOM and either of the two inputs will appear mostly across the 40 kΩ resistor. The power dissipated in the resistor is approximately 1.44W for a 240 V fault.

Each current source is protected by a MOSFET and a diode. The MOSFET is an n-channel enhancement mode device. The RTD EXC and  $R_Z$  EXC pins are normally about -3.5 V with respect to ICOM. The voltage at  $+V_{ISO}$  is about +6.5 V, yielding a  $V_{GS}$  of about 10 V. For normal operation, the FET must be saturated on. A device with a threshold voltage of less than 5 V at 1 mA  $I_{DS}$  guarantees saturation.

The  $V_{DS}$  breakdown voltage must be greater than the expected fault voltage. At 240 V rms, the peak voltage is 339V, so the FET must have a breakdown voltage of at least 350 V. The power dissipation requirements are minimal, however. The power dissipated in the FET under fault mode is  $240 \text{ V} \times 0.25 \text{ mA} \times 0.5 = 30 \text{ mW}$ . The factor of 0.5 is due to the 50% duty cycle. This allows a compact TO-92 packaged device, such as the VN0650.

During the other half of the cycle, the fault voltage is applied across the series diode. The diode must have a reverse breakdown voltage of at least 350 V.

**Other RTD Measurements.** The 1B41 can be configured for making differential measurements using 2-wire RTDs. As shown in Figure 4, the two RTDs are connected between ICOM and HI and LO. The current sources at  $R_Z$  EXC and RTD EXC create a differential signal across HI and LO that is proportional to the difference in resistance of the two RTDs. The following equation shows how to calculate  $R_G$  for applications where hardware linearization is not desired.

$$R_G = \frac{40 \text{ k}\Omega}{G - 2}$$

The LIN pins (Pins 33 and 36) must be left unconnected to maintain a constant current source.

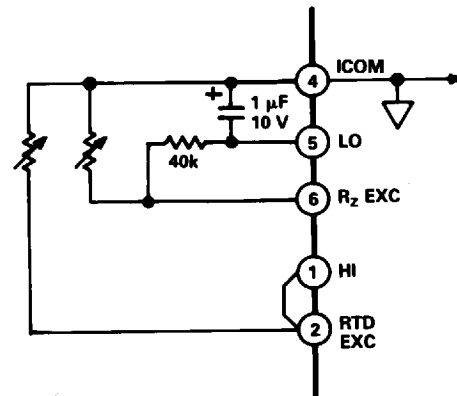

Figure 4. Differential RTD Measurement

# Mouser Electronics

Authorized Distributor

Click to View Pricing, Inventory, Delivery & Lifecycle Information:

[Analog Devices Inc.:](#)

[1B41AN](#) [1B41BN](#)