

Evaluates: LT8349 in 6V Output Voltage Application

General Description

The EVAL-LT8349-BZ evaluation board provides a proven design to evaluate the LT8349, 2-Phase low I_Q , synchronous boost converter. The application circuit is configured to demonstrate optimum performance and component size. Using the board layout example, optimized for conducted, radiated EMI, and thermal performance, will help ensure the designer sees similar performance in their system.

The evaluation board is configured to run at 2MHz per phase with a 6V output voltage from an input voltage range of 2.5V to 4.5V and deliver up to 5A load current when V_{IN} is 4.5V.

The evaluation board features an adjustable input undervoltage-lockout, external clock synchronization, thermal shutdown, selectable mode of operation and selectable Burst Mode peak current.

The [LT8349 converter data sheet](#) provides a complete description of the part that should be read in conjunction with this user guide before operating the evaluation board.

Features and Benefits

- Input Voltage Range: 2.5V to 4.5V
- 6V Output Voltage
- Up to 5A Load Current at 4.5V input voltage
- 2MHz (per phase) Switching Frequency
- High 97.1% Efficiency ($V_{IN} = 4.5V$, $I_{OUT} = 1A$)
- Enable/UVLO Input, Resistor-Programmable UVLO Threshold
- Selectable Mode of operation (See [Table 1](#) for more details)
- Selectable Burst Mode Peak Current (I_{PK_BURST}) levels for optimization of performance (See [Table 2](#) for more details)
- External Frequency Synchronization
- External Compensation
- Overtemperature Protection
- Proven Printed Circuit Board (PCB) Layout
- Fully Assembled and Tested
- Complies with CISPR32 (EN55032) Class B Conducted and Radiated Emissions

Quick Start

Required Equipment

- One 5.5V, 8A DC Power Supply
- Digital Multimeters (DMM)
- Load Resistors Capable of Sinking up to 5A at 6V output

Procedure

The evaluation board is fully assembled and tested. Follow the steps below to verify the board operation.

Caution: Do not turn on the power supply until all connections are completed

- Disable the power supply and set the input-power supply at a voltage between 2.5V to 4.5V.
- Connect the positive terminal of the power supply to the VIN or VIN_EMI PCB pad and the negative terminal to the nearest PGND PCB pad.
- Connect the positive terminal of the load to the VOUT or VOUT_EMI PCB pad and the negative terminal to the nearest PGND PCB pad.

Caution: Do not enable the Load until the power supply is turned on.

- Connect the DMM across the VOUT_SENSE PCB pad and the nearest PGND PCB pad.
- Verify that the shunts are not installed across pins on jumper J1. See [Table 1](#) for more details.
- Verify that the shunts are installed properly across pins on jumper J2. See [Table 2](#) for more details.
- Verify that the shunts are installed properly across pins on jumper J3. See [Table 3](#) for more details.
- Turn on the input-power supply.
- Enable the load.
- Verify that the DMM displays the expected terminal voltage with respect to PGND.

[Ordering Information](#) appears at end of data sheet

EVAL-LT8349-BZ Configuration

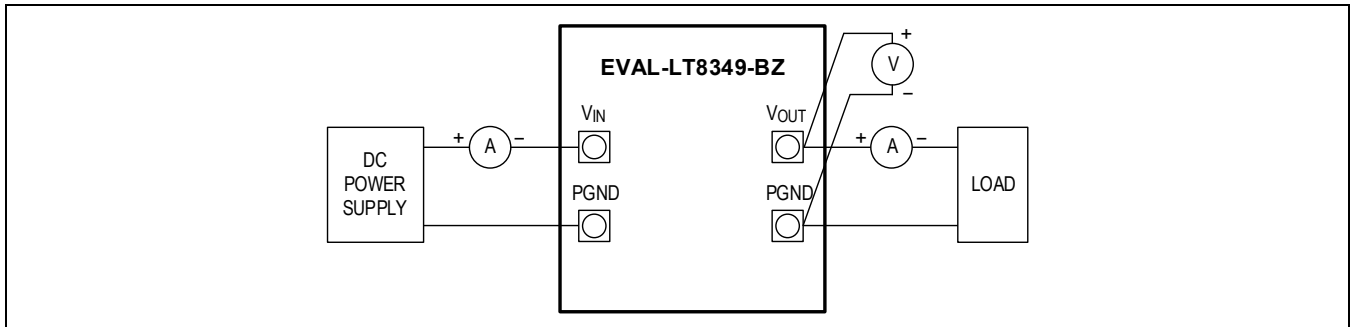

Figure 1. EVAL-LT8349-BZ Board Connections

Typical Performance Characteristics

$T_A = 25^\circ\text{C}$, all measurements are in reference to [EVAL-LT8349-BZ Schematic](#). Source connected between V_{IN} and PGND and Load connected between V_{OUT} and PGND, unless otherwise noted.

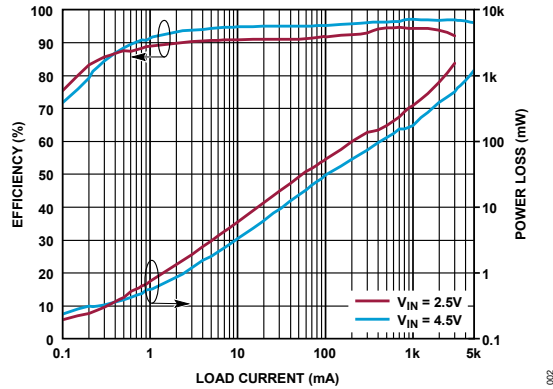

Figure 2. Efficiency and Power Loss vs Output Current (Burst Mode, $I_{SET} = V_{IN}$)

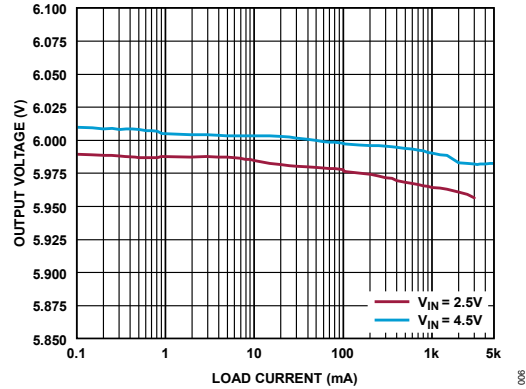

Figure 3. Output Voltage vs Output Current (Burst Mode, $I_{SET} = V_{IN}$)

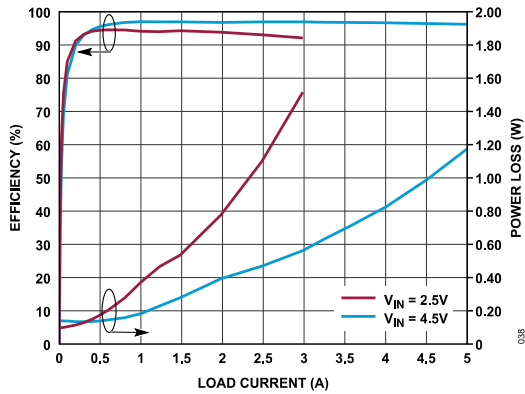

Figure 4. Efficiency and Power Loss vs Output Current (Field Control Module (FCM) Mode, $I_{SET} = V_{IN}$)

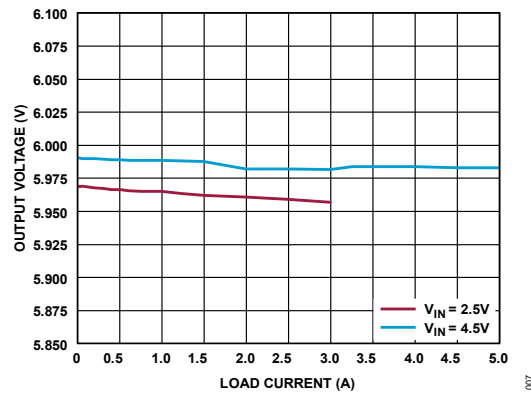

Figure 5. Output Voltage vs Output Current (FCM Mode, $I_{SET} = V_{IN}$)

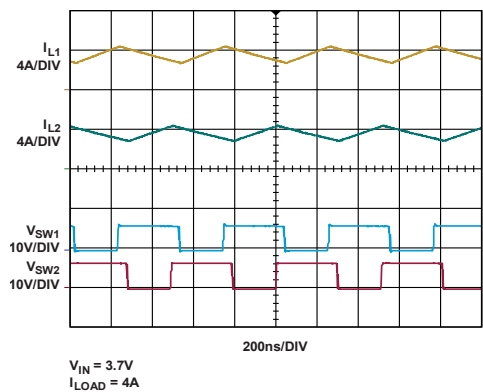

Figure 6. Switching Waveforms, Heavy Load 2-Phase Operation

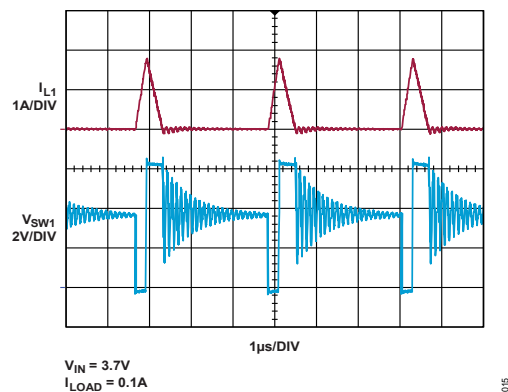

Figure 7. Switching Waveforms, Light Load 1-Phase Burst Mode Operation

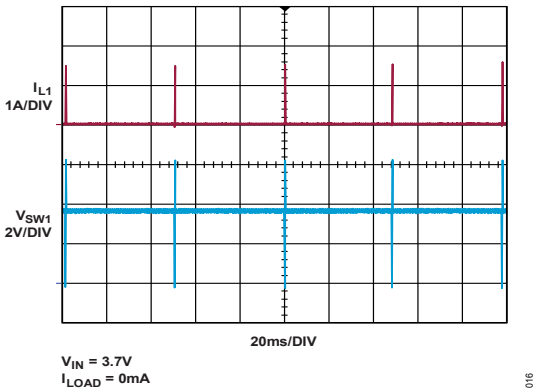

Figure 8. Switching Waveforms, Zero Load 1-Phase Burst Mode Operation

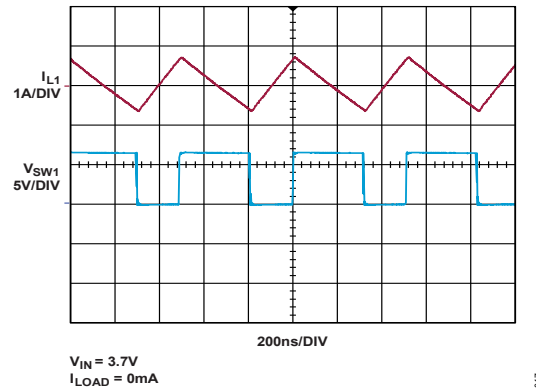

Figure 9. Switching Waveforms, Zero Load 1-Phase FCM Operation

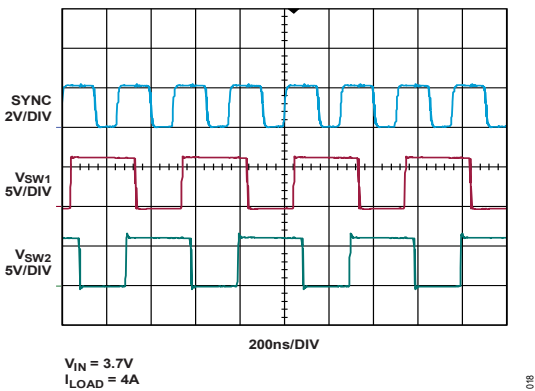

Figure 10. Switching Waveforms, Heavy Load 2-Phase Operation with SYNC

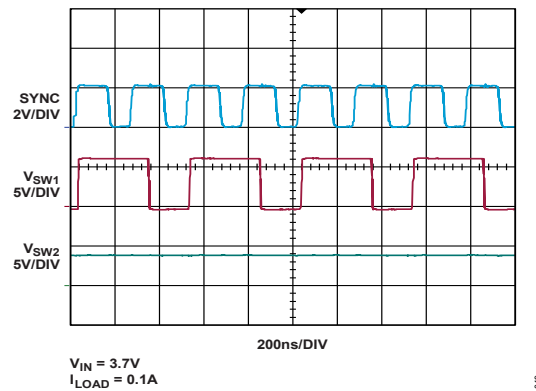

Figure 11. Switching Waveforms, Light Load 1-Phase Operation with SYNC

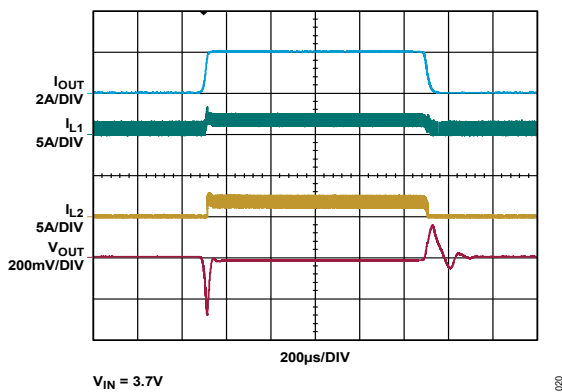

Figure 12. Transient Response Burst Mode Operation

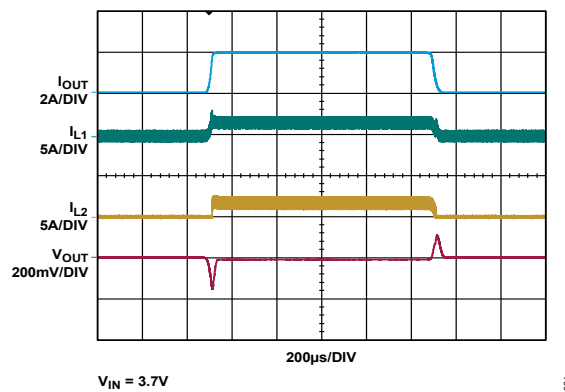

Figure 13. Transient Response FCM Mode Operation

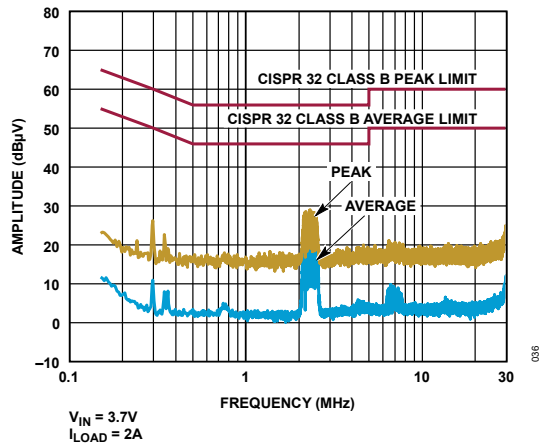

Figure 14. CISPR32 Conducted EMI measured on EVAL-LT8349-BZ with Spread Spectrum Frequency Modulation (SSFM) mode
 Source connected between VIN_EMI and PGND Load connected between VOUT_EMI and PGND

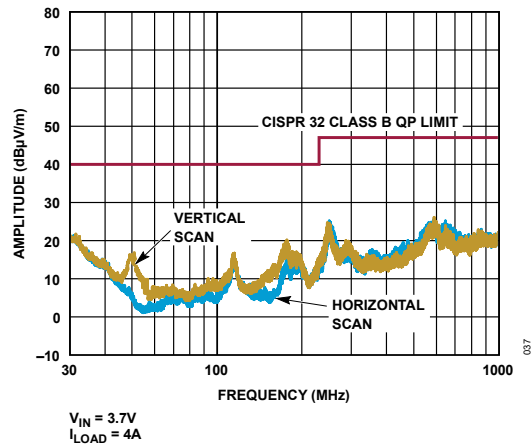

Figure 15. CISPR32 Radiated EMI measured on EVAL-LT8349-BZ with SSFM mode
 Source connected between VIN_EMI and PGND Load connected between VOUT_EMI and PGND

Detailed Description

The EVAL-LT8349-BZ evaluation board is designed to demonstrate the salient features of the LT8349 2-Phase Low I_Q Synchronous Boost Converter. The evaluation board is preset for 6V output from 2.5V to 4.5V input and can deliver load current up to 3A at 2.5V input voltage and up to 5A at 4.5V input voltage with 2MHz switching frequency per phase.

Enable/Undervoltage Lockout (EN/UVLO) Programming

The evaluation board offer an adjustable input undervoltage-lockout feature. When jumper J1 is left open, the EVAL-LT8349-BZ is enabled when the input voltage rises above $V_{IN_UVLO_R}$. Install the shunt across pins 2–3 on jumper J1 to disable. See [Table 1](#) for jumper settings.

Table 1. EN/UVLO Jumper Description (J1)

SHUNT POSITION	EN/UVLO PIN	OUTPUT
Not Installed*	Connected to the center node of the resistor-divider R1 and R2	Enabled, UVLO level set through the R1 and R2 resistors
1-2	Connected to V_{IN}	Enabled, when $V_{IN} > V_{IN_UVLO_R}$
2-3	Connected to PGND	Disabled

*Default Position

MODE Selection and External Clock Synchronization

The LT8349 supports five different modes of operation: Burst Mode, Burst Mode with SSFM, Forced Conduction Mode, Forced Conduction Mode with SSFM, and Forced Conduction Mode (FCM) with External Clock Synchronization. See [Table 2](#) for jumper J2 settings.

The internal oscillators of the converter can be synchronized to an external clock signal on the MODE/SYNC pin. By providing a digital clock signal to the SYNC/MODE pin, the IC operates at half the SYNC clock frequency and automatically enters FCM operation at light load. If this feature is used, an RT resistor should be chosen to program the switching frequency close to the external clock frequency. Refer to the *Switching Frequency and Synchronization* section in the [LT8349 data sheet](#) for more details.

Table 2. Mode Jumper Description (J2)

SHUNT POSITION	MODE/SYNC PIN	OPERATING MODE
1-2*	Connected to SGND	Burst Mode of Operation
3-4	Connected to 51kΩ to SGND	Burst + SSFM Mode of Operation
5-6	Float	FCM Mode of Operation
7-8	Connected to V_{IN}	FCM + SSFM Mode of Operation
9-10	Connected to External Clock	Synchronized to External Clock

*Default Position

Setting Burst Mode Peak Current Limit (ISET)

The LT8349 supports 3 different settings for Burst Mode Peak Current Limit (I_{PK_BURST}). EVAL-LT8349-BZ provides a jumper J3 to select between these settings. See [Table 3](#) for jumper J3 settings.

Table 3. ISET Jumper Description (J3)

SHUNT POSITION	ISET PIN	BURST MODE PEAK CURRENT
1-2*	Connected to VIN	1.7A (typ.)
3-4	Float	1.47A (typ.)
5-6	Connected to SGND	1.23A (typ.)

*Default Position

Setting Switching Frequency

The switching frequency of the EVAL-LT8349-BZ can be programmed from 300kHz to 4MHz by using a resistor connected from the RT pin to SGND. Resistor R5 programs the desired switching frequency. To optimize performance and component size in the Evaluation board, a 2MHz switching frequency has been chosen. Use the *Switching Frequency and Synchronization* section of the [LT8349 data sheet](#) to select different resistor values for programming the required switching frequency.

Adjusting Output Voltage

The LT8349 supports an adjustable output voltage of up to 8V. EVAL-LT8349-BZ evaluation board is configured to 6V output. The output voltage is programmed using the resistor dividers R7 and R8. Refer to the *FB Resistor Network* section in the [LT8349 data sheet](#) for more details.

Input Capacitor Selection

The input capacitors, C10 and C11, reduce current peaks drawn from the input-power supply and reduce the switching frequency ripple at the input. Refer to the *Input Capacitor Selection* section in the [LT8349 data sheet](#) to choose input capacitance. The input capacitors are chosen to be 22 μ F/10V/X5R.

Output Capacitor Selection

The output capacitors C23–C25, C29–C31 are chosen as 22 μ F/10V/X5R. Refer to the *Output capacitor selection* section in the [LT8349 data sheet](#) for more details.

Hot Plug-In and Long input cables

The EVAL-LT8349-BZ evaluation board provides an optional electrolytic capacitor C9 (220 μ F/16V) to dampen input voltage peaks and oscillations arising during hot-plug-in and/or due to long input cables. These capacitors limit the peak voltage at the input of the DC-DC converters when the evaluation board is powered directly from a precharged capacitive source or an industrial backplane PCB. Long input cables between an input-power source and the evaluation board circuit can cause input-voltage oscillations due to the inductance of the cables. The equivalent series resistance (ESR) of the electrolytic capacitor helps damp out the oscillations caused by long input cables.

Electromagnetic Interference (EMI)

Compliance with conducted emissions (CE) standards requires an EMI filter at the input of a switching power converter. The EMI filter attenuates high-frequency currents drawn by the switching power converter and limits the noise injected back into the input power source.

The use of EMI filter components, as shown in the [EVAL-LT8349-BZ Schematic](#), results in lower conducted emissions below CISPR32 Class B limits. The PCB layout is also designed to limit radiated emissions from switching nodes of the power converter, resulting in radiated emissions below CISPR32 Class B limits. Further, capacitors placed near the input of the board help attenuate high-frequency noise. EMI filters may not be necessary for all applications. For a lower parts count and Bill of Materials (BOM) cost, EMI filters can be removed.

Ordering Information

PART	TYPE
EVAL-LT8349-BZ	Evaluation Board

Component Suppliers

SUPPLIER	WEBSITE
Murata Americas	www.murata.com
Coilcraft	www.coilcraft.com
Vishay	www.vishay.com
Panasonic Corp.	www.panasonic.com
Yageo	www.yageo.com

Note: Indicate that you are using the LT8349 when contacting these component suppliers.

EVAL-LT8349-BZ Bill of Materials

ITEM	QTY	REFERENCE	PART DESCRIPTION	MANUFACTURER/ PART NUMBER
Required Evaluation Kit Components				
1	8	C1, C5, C22, C37, C41, C42, C43, C44	CAP., X7R, 0.1µF, 25V, 10%, 0402	MURATA, GRM155R71E104KE14D
2	5	C2, C3, C4, C8, C36	CAP., X7R, 2.2µF, 10V, 10%, 0603	MURATA, GRM188R71A225KE15D
3	2	C6, C7	CAP., X5R, 100µF, 10V, 20%, 1210	SAMSUNG, CL32A107MPVNNNE
4	1	C9	CAP., ALUM 220µF 16V	NICHICON, UCW1C221MCL1GS
5	8	C10, C11, C23, C24, C25, C29, C30, C31	CAP., X5R, 22µF, 10V, 20%, 0603	TDK, C1608X5R1A226M080AC
6	1	C12	CAP., X7R, 1.0µF, 16V, 10%, 0402	TDK, C1005X6S1C105K050BC
7	1	C13	CAP., C0G, 4.7pF, 50V, 10% 0402	AVX, 04025U4R7BAT2A
8	1	C14	CAP., X7R, 470pF, 25V, 10%, 0402	KEMET, C0402C471K3RACTU
9	2	C15, C16	CAP., X5R, 0.1µF, 25V, 10%, 0201	MURATA, GRM033R61E104KE14D
10	2	C18, C19	CAP., X7R, 1000pF, 25V, 10%, 0201	MURATA, GCM033R71E102KA03D
11	4	C20, C21, C39, C40	CAP., C0G, 220pF, 200V, 5%, 0402	KEMET, C0402C221J2GACTU
12	2	L1, L2	IND., 0.47µH, 4.8A	WÜRTH, 744383360047
13	1	FB1	FERRITE BEAD, 6mΩ DCR, 8A	WÜRTH, 74279226101
14	1	FB2	FERRITE BEAD, 9mΩ DCR, 6A	MURATA, BLM31KN121SN1L
15	2	R1, R7	RES., CHIP, 1Meg, 1/10W, 1%, 0402	PANASONIC, ERJ-2RKF1004X
16	1	R2	RES., CHIP, 665K, 1/10W, 1%, 0402	PANASONIC, ERJ-2RKF6653X
17	1	R3	RES., CHIP, 8.2K, 1/10W, 1%, 0402	PANASONIC, ERJ-2RKF8201X
18	1	R4	RES., CHIP, 51K, 1/10W, 1%, 0402	PANASONIC, ERJ-2RKF5102X
19	1	R5	RES., CHIP, 54.9K, 1/10W, 1%, 0402	PANASONIC, ERJ-2RKF5492X
20	2	R6, R9	RES., CHIP, 0, 1/10W, 1%, 0402	PANASONIC, ERJ-2GE0R00X
21	1	R8	RES., CHIP, 200K, 1/10W, 1%, 0402	PANASONIC, ERJ-2RKF2003X
22	1	U1	IC, REGULATOR, 35-WLCSP	ANALOG DEVICES, LT8349ACBZ
Hardware for Evaluation Kit Only				
1	11	EN/UVLO, PGND, SGND, SYNC, VIN_EMI, VIN_SENSE, VOUT_EMI, VOUT_SENSE	TESTPOINT, TURRET, 0.156"	MILL-MAX, 2308-2-00-80-00-00-07-0
2	3	C26, C32, C35	NA	PACKAGE OUTLINE 0603 NON-POLAR CAPACITOR - EVKIT
3	1	J1	CONN-PCB 3POS MALE HDR	SULLINS NRPN042PAEN-RC
4	1	J2	CONN-PCB 2MM P DIL	SAMTEC INC., TMM-105-01-F-D
5	1	J3	CONN-PCB 6POS UNSHROUDED HEADER VERT 2MM PITCH	SAMTEC INC., TMM-103-02-L-D

EVAL-LT8349-BZ Schematic

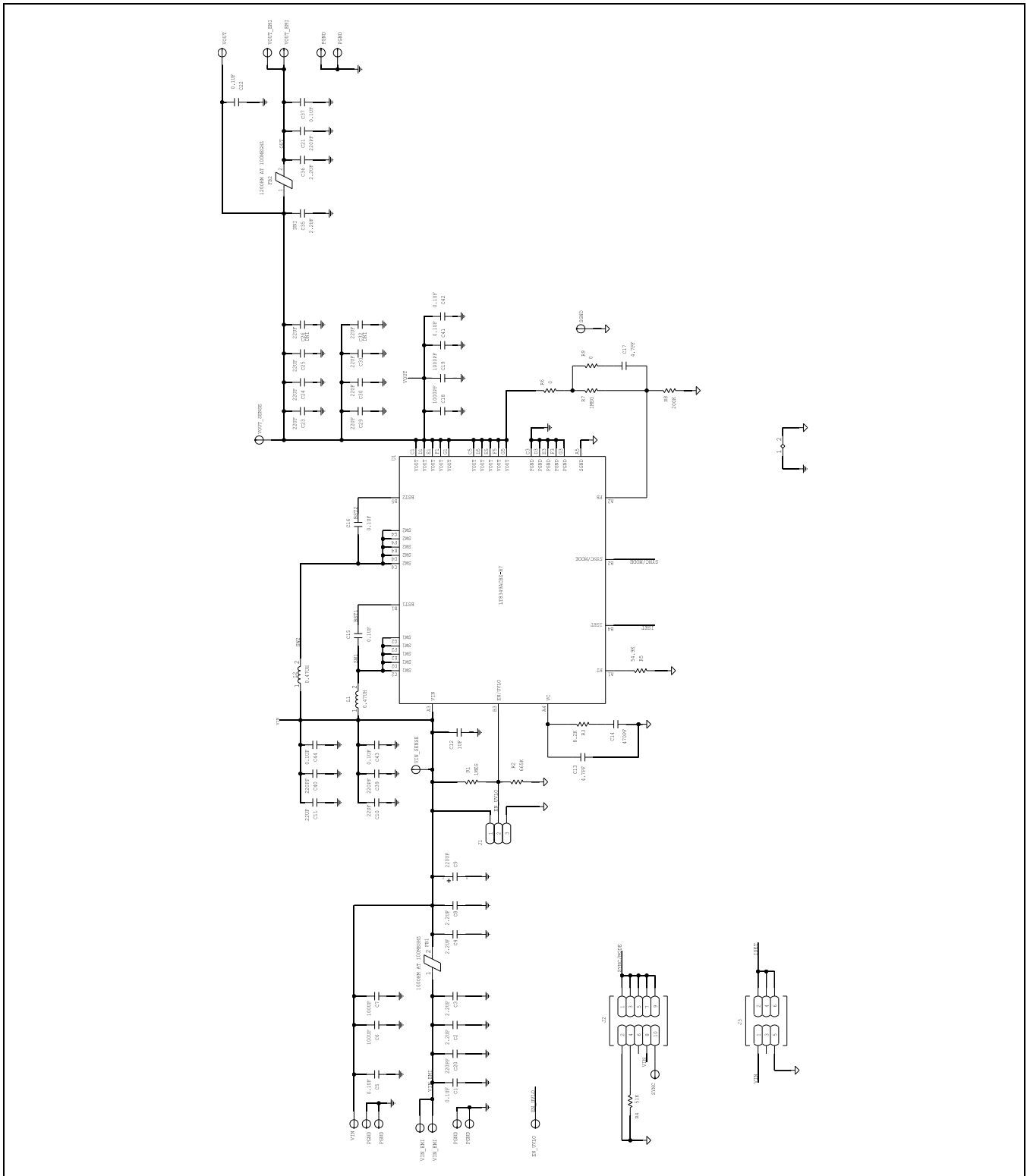

EVAL-LT8349-BZ PCB Layout

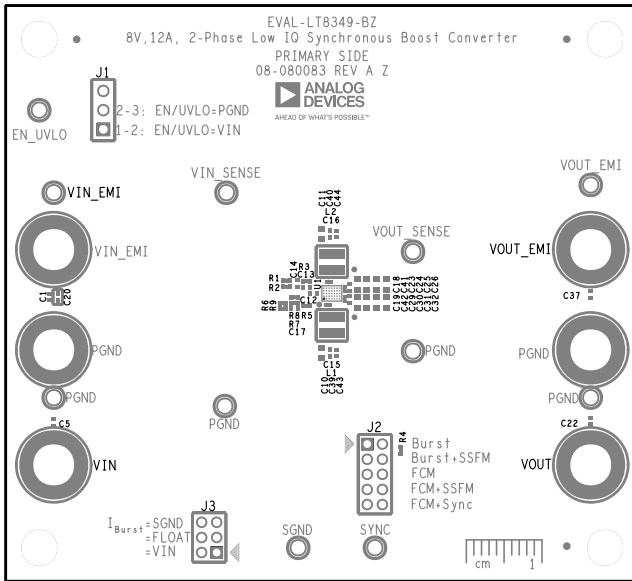

EVAL-LT8349-BZ Component Placement Guide—Top Silkscreen

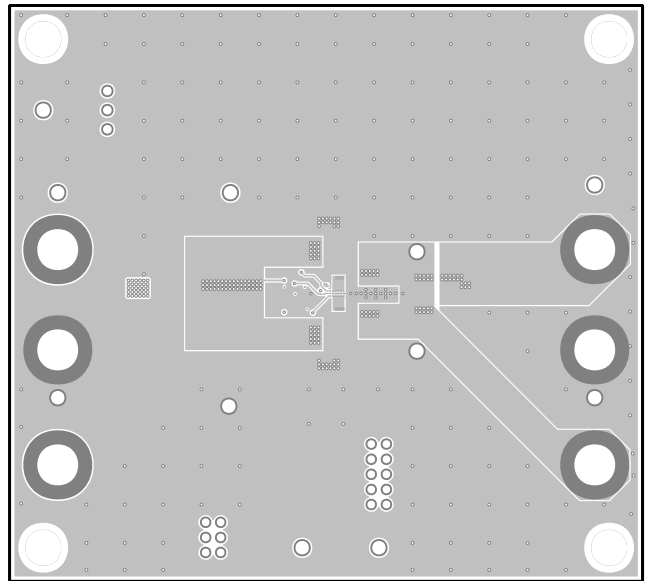

EVAL-LT8349-BZ PCB Layout—Layer 2

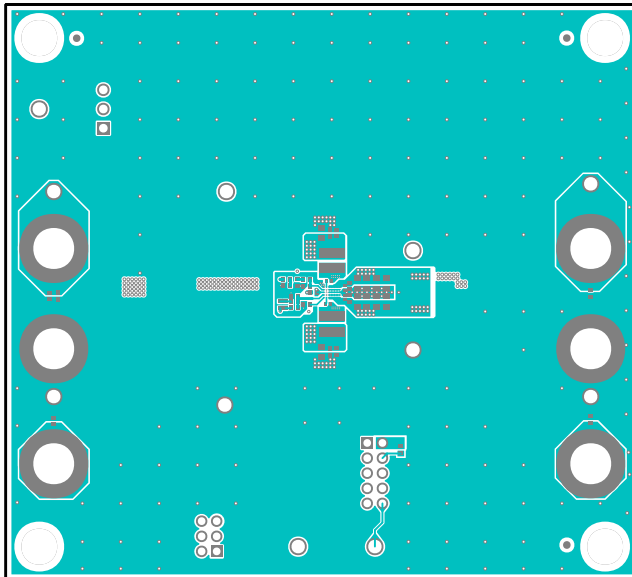

EVAL-LT8349-BZ PCB Layout—Layer 1

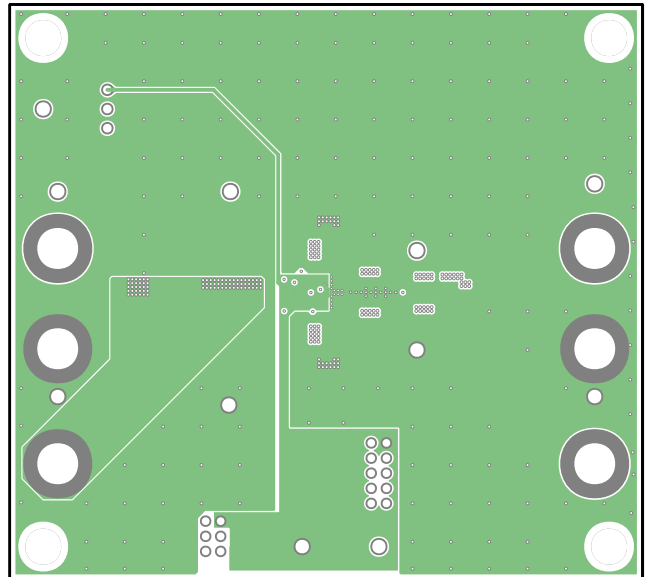

EVAL-LT8349-BZ PCB Layout—Layer 3

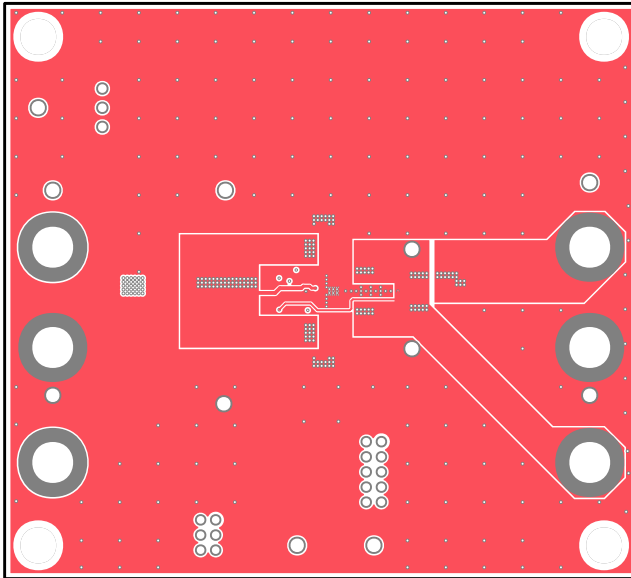

EVAL-LT8349-BZ PCB Layout—Layer 4

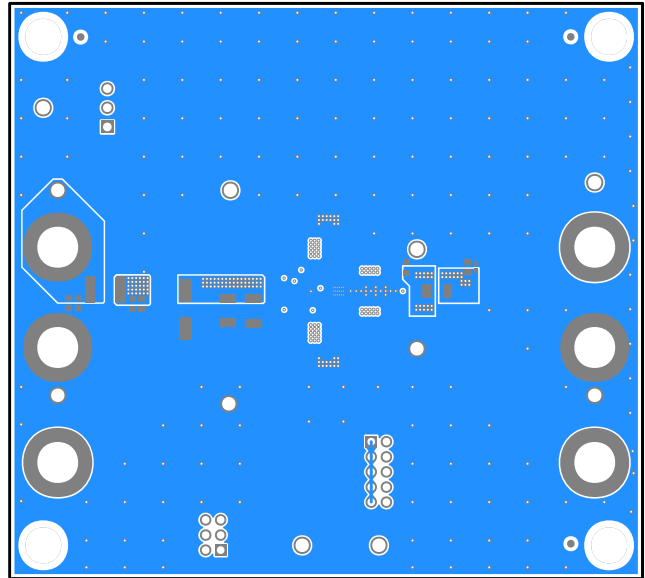

EVAL-LT8349-BZ PCB Layout—Layer 6

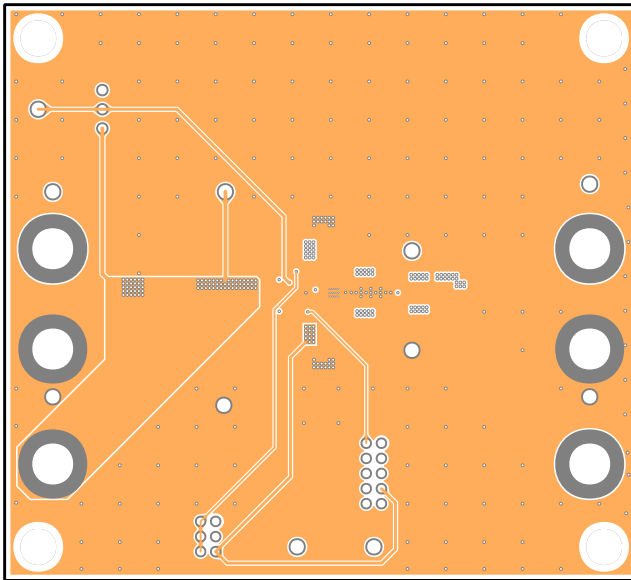

EVAL-LT8349-BZ PCB Layout—Layer 5

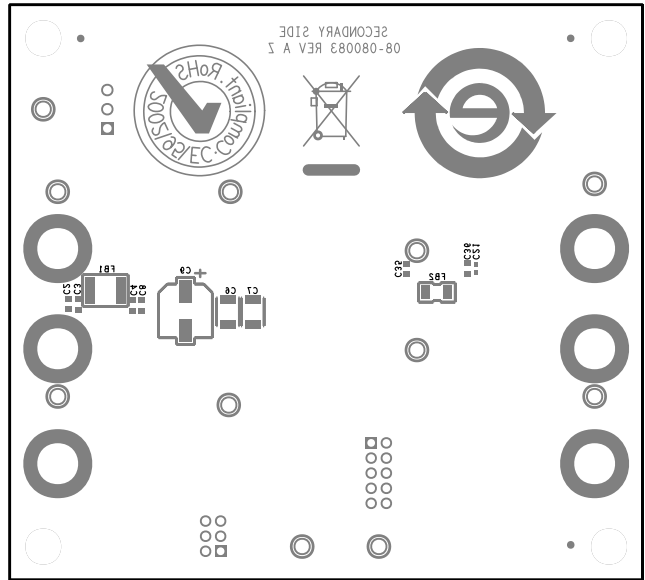

EVAL-LT8349-BZ Component Placement Guide—Bottom Silkscreen

Revision History

REVISION NUMBER	REVISION DATE	DESCRIPTION	PAGES CHANGED
0	02/24	Initial release	—

ASSUMED BY ANALOG DEVICES FOR ITS USE, NOR FOR ANY INFRINGEMENTS OF PATENTS OR OTHER RIGHTS OF THIRD PARTIES THAT MAY RESULT FROM ITS USE. SPECIFICATIONS ARE SUBJECT TO CHANGE WITHOUT NOTICE. NO LICENCE, EITHER EXPRESSED OR IMPLIED, IS GRANTED UNDER ANY ADI PATENT RIGHT, COPYRIGHT, MASK WORK RIGHT, OR ANY OTHER ADI INTELLECTUAL PROPERTY RIGHT RELATING TO ANY COMBINATION, MACHINE, OR PROCESS WHICH ADI PRODUCTS ALL INFORMATION CONTAINED HEREIN IS PROVIDED "AS IS" WITHOUT REPRESENTATION OR WARRANTY. NO RESPONSIBILITY IS OR SERVICES ARE USED. TRADEMARKS AND REGISTERED TRADEMARKS ARE THE PROPERTY OF THEIR RESPECTIVE OWNERS.

Mouser Electronics

Authorized Distributor

Click to View Pricing, Inventory, Delivery & Lifecycle Information:

[Analog Devices Inc.:](#)

[EVAL-LT8349-BZ](#)