

General Description

The ADPL44002 evaluation boards evaluate the ADPL44002, a 40V, 200mA, low noise, CMOS, low dropout (LDO) linear regulator.

See the [Ordering Information](#) section for the two types of evaluation boards available to evaluate the ADPL44002. There is an evaluation board that features a 6-lead, 2mm x 2mm LFCSP package, and there is also an evaluation board that features a 5-lead TSOT package.

The evaluation boards provide a 3.3V output over an input range of 3.8V to 40V. The maximum output current is 200mA, but output current is also limited by the thermal dissipation of the ADPL44002. The evaluation boards use the adjustable version of ADPL44002. A resistor divider programs the output of the adjustable ADPL44002 to 3.3V. Noise performance for the adjustable ADPL44002 can be made comparable to a fixed output ADPL44002 by installing optional RC network components into placeholders that the evaluation board printed circuit board (PCB) designs provide. The evaluation boards can easily be configured with a jumper for fixed output versions of the ADPL44002 that normally have their SENSE/ADJ pin connected directly to the output.

In addition to connectors for the input voltage, output voltage, EN control signal and ground, the evaluation boards provide test points for the input, output, and SS pin voltages. A jumper normally connects the EN pin to the V_{IN} input, but the jumper can be repositioned so EN can be driven externally at its connector instead.

For more details, refer to the ADPL44002 data sheet, which must be consulted in addition to this user guide when using the ADPL44002 evaluation boards.

Features and Benefits

- Input Voltage Range: 3.8V to 40V
- Resistor Programmed 3.3V Output Voltage
- Maximum Output Current: 200mA
- Jumper Turns Regulator On or Connects the EN Pin to a Connector to Turn the Regulator On or Off Externally
- Jumper Connects the SENSE/ADJ Pin to the Output Through a Resistor Divider or Directly
- V_{IN} , V_{OUT} , and GND Test Points for Regulation and Dropout Voltage Monitoring
- Component Placeholders for an RC Network that can Reduce Noise when the SENSE/ADJ Pin Connects to the Output Through a Resistor Divider
- Component Placeholder for a Soft-Start Capacitor and SS Test Point for Soft-Start Voltage Monitoring - LFCSP Package Evaluation Board Only
- 6-Lead 2mm x 2mm LFCSP Package or a 5-Lead TSOT Package

[Ordering Information](#) appears at end of data sheet.

Quick Start

Required Equipment

- A DC power supply
- Multimeters for voltage and current measurements
- Electronic or resistive loads

Procedure

The ADPL44002 evaluation boards are simple to set up to evaluate the performance of the ADPL44002. See [Figure 1](#) or [Figure 2](#) for the evaluation board connections, and take the following steps:

1. Connect the load between the V_{OUT} and GND terminals.
2. With the input power supply off and turned down, connect the input supply to the V_{IN} and GND terminals. Ensure that the shunt of JP1 connects EN to V_{IN} according to the jumper connection guide. Also ensure that the shunt of JP2 allows the resistor divider to program the output to 3.3V according to the jumper connection guide.
3. With the load turned down, turn the input power supply on and increase the voltage to 3.8V or higher.
4. Vary V_{IN} from 3.8V to 40V and the load current from 0A to 200mA. **Observe conservative power dissipation limits** and note the following when setting V_{IN} and the load current:
 - An input voltage that is too close to the programmed output voltage (too low) can cause dropout operation and a loss of output-voltage regulation.
 - The amount of output current combined with an input voltage that is too high above the output can increase power dissipation to an unacceptable level.
5. Monitor regulation and dropout voltage at the V_{IN} , V_{OUT} , and GND test points.
5. To apply an EN signal externally, reposition jumper JP1 and apply the EN signal to the EN connector.
6. If an output voltage other than 3.3V is desired, change resistors R1 and R2.
7. An RC network can be installed in the component placeholder locations in parallel with the top feedback divider resistor R1 to improve noise performance. Refer to the ADPL44002 data sheet for details.
8. JP2 is a convenient way to connect the SENSE/ADJ pin directly to the output if a fixed-output ADPL44002 is installed. The bottom feedback divider resistor R2 may be removed as well.
9. On the LFCSP package version evaluation board only, monitor the soft start voltage at the SS test point, and a soft start capacitor can be installed in the C3 placeholder.

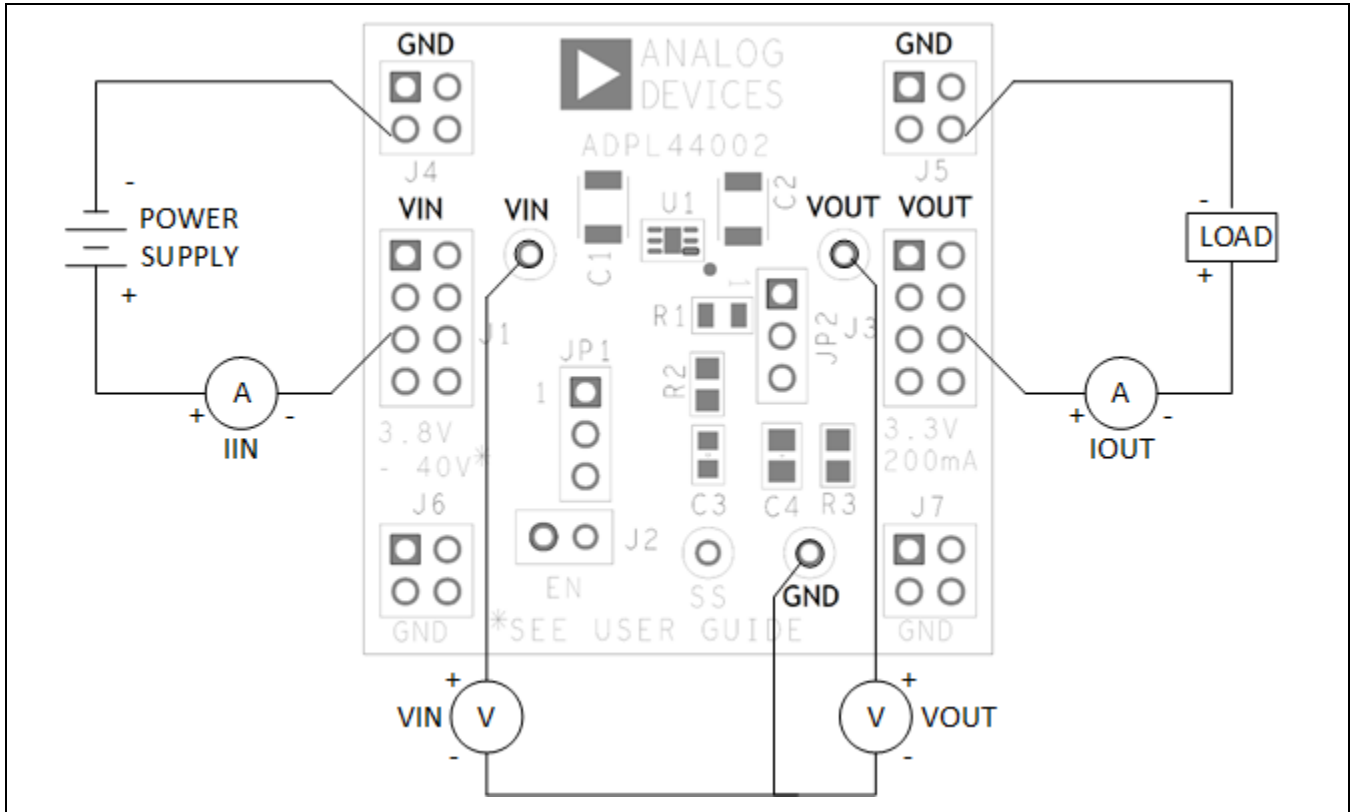

Figure 1. LFCSP Package Evaluation Board Connections

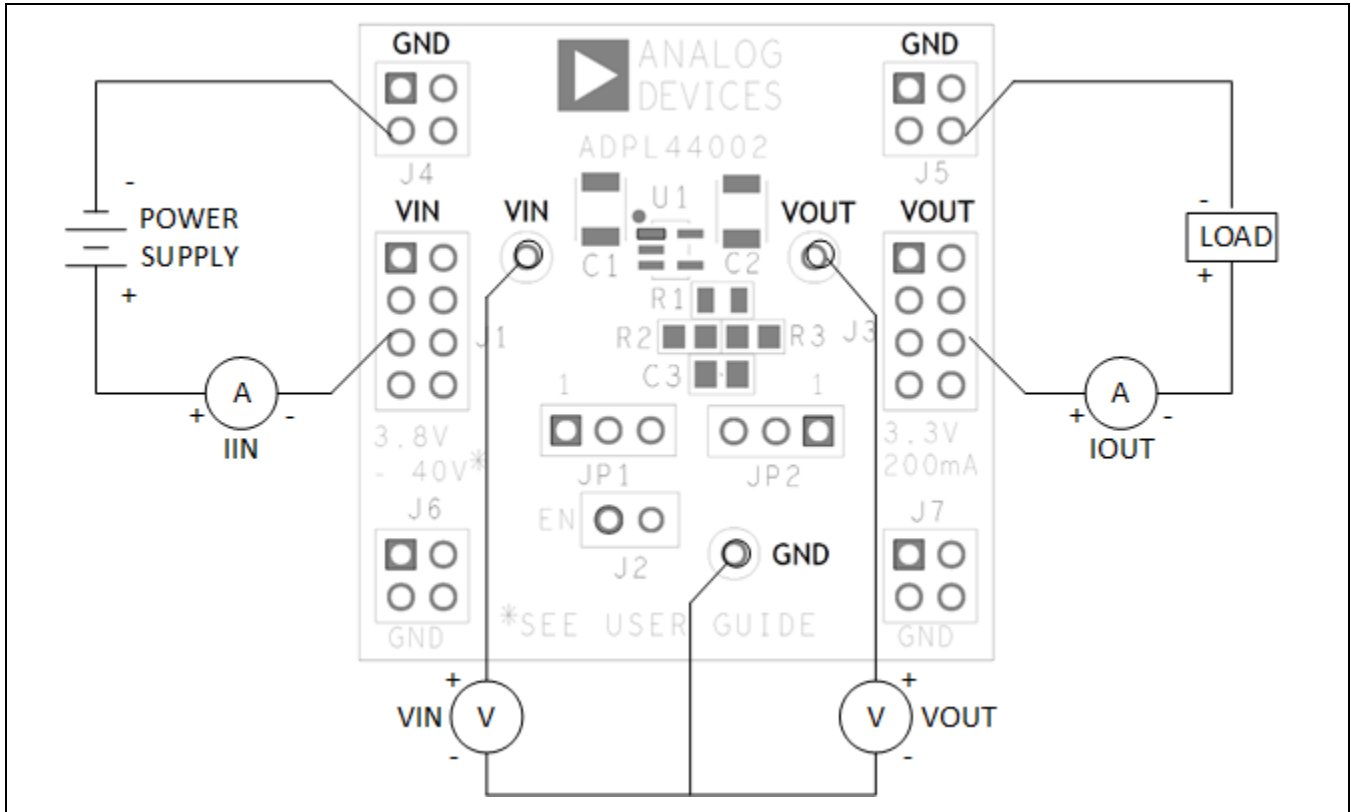

Figure 2. TSOT Package Evaluation Board Connections

Performance Summary

Specifications are at $T_A = +25^\circ\text{C}$, unless otherwise noted.

Table 1. Performance Summary of the LFCSP Package Evaluation Board

PARAMETER	SYMBOL	TEST CONDITIONS/COMMENTS	MIN	TYP	MAX	UNIT
Input Voltage Range	V_{IN}	$I_{OUT} = 10\text{mA}$, $V_{OUT} = 3.3\text{V}$	3.8		40	V
Input Voltage Range	V_{IN}	$I_{OUT} = 200\text{mA}$, $V_{OUT} = 3.3\text{V}$	3.8		10.2 ¹	V
Output Voltage	V_{OUT}	$V_{IN} = 5\text{V}$, $I_{OUT} = 200\text{mA}$, $R_1 = 17.4\text{k}\Omega$, $R_2 = 10\text{k}\Omega$	3.22	3.29	3.36	V
Feedback Divider Current	I_{FB}	JP1 = pins 2-3, JP2 = pins 1-2, $R_1 = 17.4\text{k}\Omega$, $R_2 = 10\text{k}\Omega$		120		μA
Shutdown Input Current	I_{GND_SD}	JP1 = pins 1-2, $V_{IN} = 4.3\text{V}$, EN = GND		1.8		μA

¹ The maximum power dissipation and, consequently, the maximum input voltage for an output that is programmed to 3.3V with a 200mA load is determined by the 60°C temperature rise of the ADPL44002 on the evaluation board. In addition, consider the effect of ambient temperature and the maximum junction temperature that may occur. Refer to the ADPL44002 data sheet for more information.

Table 2. Performance Summary of the TSOT Package Evaluation Board

PARAMETER	SYMBOL	TEST CONDITIONS/COMMENTS	MIN	TYP	MAX	UNIT
Input Voltage Range	V_{IN}	$I_{OUT} = 10\text{mA}$, $V_{OUT} = 3.3\text{V}$	3.8		40	V
Input Voltage Range	V_{IN}	$I_{OUT} = 200\text{mA}$, $V_{OUT} = 3.3\text{V}$	3.8		6.6 ¹	V
Output Voltage	V_{OUT}	$V_{IN} = 5\text{V}$, $I_{OUT} = 200\text{mA}$, $R_1 = 17.4\text{k}\Omega$, $R_2 = 10\text{k}\Omega$	3.22	3.29	3.36	V
Feedback Divider Current	I_{FB}	JP1 = pins 2-3, JP2 = pins 1-2, $R_1 = 17.4\text{k}\Omega$, $R_2 = 10\text{k}\Omega$		120		μA
Shutdown Input Current	I_{GND_SD}	JP1 = pins 1-2, $V_{IN} = 4.3\text{V}$, EN = GND		1.8		μA

¹ The maximum power dissipation and, consequently, the maximum input voltage for an output that is programmed to 3.3V with a 200mA load is determined by the 60°C temperature rise of the ADPL44002 on the evaluation board. In addition, consider the effect of ambient temperature and the maximum junction temperature that may occur. Refer to the ADPL44002 data sheet for more information.

Printed Circuit Board (PCB) Layout

The printed circuit boards (PCBs) for these evaluation boards are 0.062 inches thick and 1.5 inches square. There are two copper layers, and the finished copper thickness is 2 ounces. The input capacitor, ADPL44002, and output capacitor are all placed on the top side of the PCB. The input and output capacitors are placed near the ADPL44002 with their ground terminals close to each other. The input capacitor, output capacitor, and ADPL44002 grounds all connect on one side of the device, while grounds for control signals connect to the ADPL44002 on the other side of the device. The bottom side of the PCB is a solid ground plane that connects to the ground on the top PCB layer by thermal vias under or near the ADPL44002 and at other points. Layout may significantly affect circuit electrical performance and reliability.

Jumper Connection Guide

JUMPER	DEFAULT CONNECTION	FEATURE
JP1	Pin 2-3	Turns Regulator On
JP2	Pin 1-2	Connects the SENSE/ADJ pin to the output through a resistor divider

Ordering Information

MODEL ^{1, 2}	PACKAGE DESCRIPTION
EVAL-ADPL44002CP-AZ	LFCSP Package Evaluation Board
EVAL-ADPL44002UJ-AZ	TSOT Package Evaluation Board

¹ Z = RoHS Compliant Part.

² The evaluation boards are preconfigured with an adjustable ADPL44002.

LFCSP Package Evaluation Board Bill of Materials

ITEM	QUANTITY	REFERENCE DESIGNATOR	PART DESCRIPTION	MANUFACTURER, PART NUMBER
Required Circuit Components				
1	2	C1, C2	2.2 μ F Capacitor, X7R, 100V, 10% 1210	KEMET, C1210C225K1RAC7800
2	1	R1	17.4k Ω resistor, 1%, 1/8W, 0805	Vishay, CRCW080517K4FKEA
3	1	R2	10k Ω resistor, 1%, 1/8W, 0805	Vishay, CRCW080510K0FKEA
4	1	U1	40V, 200mA, low noise, CMOS, LDO linear regulator	Analog Devices Inc., ADPL44002ACPZN-R7
Optional Evaluation Board Components				
1	0	C3	Capacitor, 0603, Optional	
2	0	C4	Capacitor, 0805, Optional	
3	0	R3	Resistor, 0805, Optional	
Hardware				
1	2	J1, J3	Connector, header, male, 2 x 4, 2.54mm, vertical, straight, through hole	Sullins, PEC04DAAN
2	1	J2	Connector, header, male, 1 x 2, 2.54mm, vertical, straight, through hole	Sullins, PEC02SAAN
3	2	JP1, JP2	Connector, header, male, 1 x 3, 2.54mm, vertical, straight, through hole	Sullins, PEC03SAAN
4	4	J4 to J7	Connector, header, male, 2 x 2, 2.54mm, vertical, straight, through hole	Sullins, PEC02DAAN
5	2	XJP1, XJP2	Connector, shunt, female, 2 position, 2.54mm	Kycon, SX1100-B

TSOT Package Evaluation Board Bill of Materials

ITEM	QUANTITY	REFERENCE DESIGNATOR	PART DESCRIPTION	MANUFACTURER, PART NUMBER
Required Circuit Components				
1	2	C1, C2	2.2 μ F Capacitor, X7R, 100V, 10% 1210	KEMET, C1210C225K1RAC7800
2	1	R1	17.4k Ω resistor, 1%, 1/8W, 0805	Vishay, CRCW080517K4FKEA
3	1	R2	10k Ω resistor, 1%, 1/8W, 0805	Vishay, CRCW080510K0FKEA
4	1	U1	40V, 200mA, low noise, CMOS, LDO linear regulator	Analog Devices Inc., ADPL44002AUJZ-R7
Optional Evaluation Board Components				
1	0	C3	Capacitor, 0805, Optional	
2	0	R3	Resistor, 0805, Optional	
Hardware				
1	2	J1, J3	Connector, header, male, 2 x 4, 2.54mm, vertical, straight, through hole	Sullins, PEC04DAAN
2	1	J2	Connector, header, male, 1 x 2, 2.54mm, vertical, straight, through hole	Sullins, PEC02SAAN
3	2	JP1, JP2	Connector, header, male, 1 x 3, 2.54mm, vertical, straight, through hole	Sullins, PEC03SAAN
4	4	J4 to J7	Connector, header, male, 2 x 2, 2.54mm, vertical, straight, through hole	Sullins, PEC02DAAN
5	2	XJP1, XJP2	Connector, shunt, female, 2 position, 2.54mm	Kycon, SX1100-B

LFCSFP Package Evaluation Board Schematic

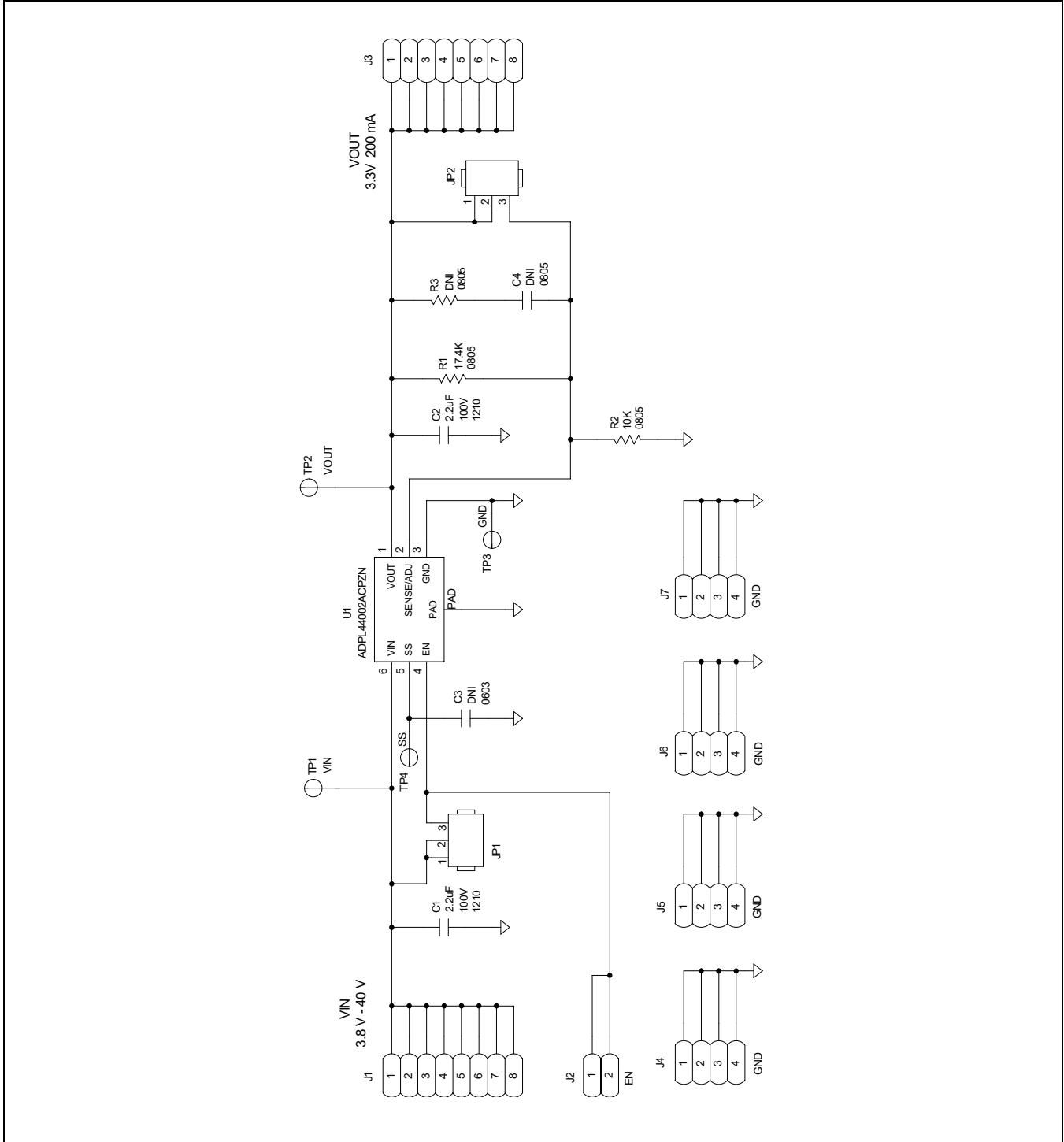

TSOT Package Evaluation Board Schematic

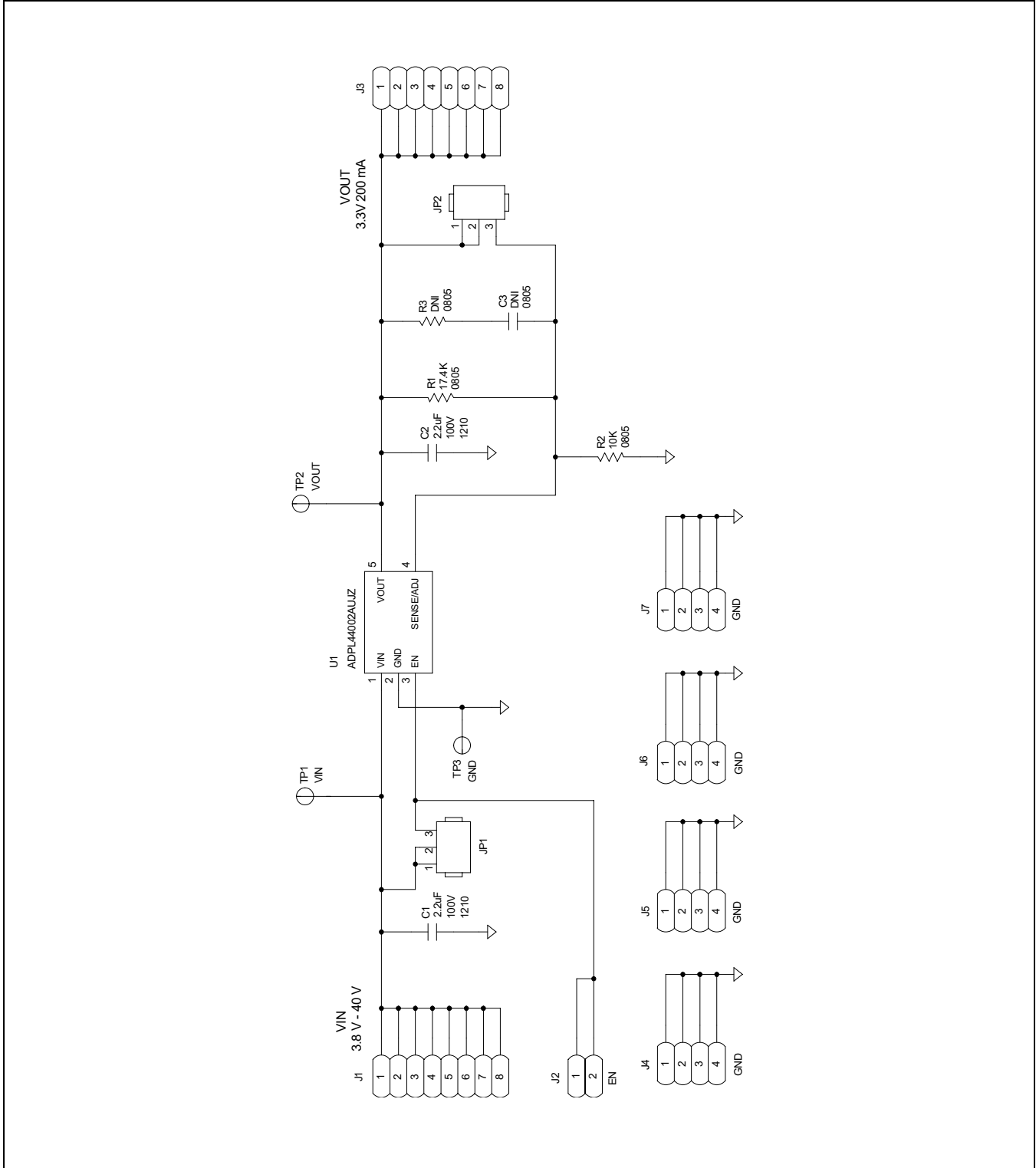

LCFSP Package Evaluation Board PCB Layout

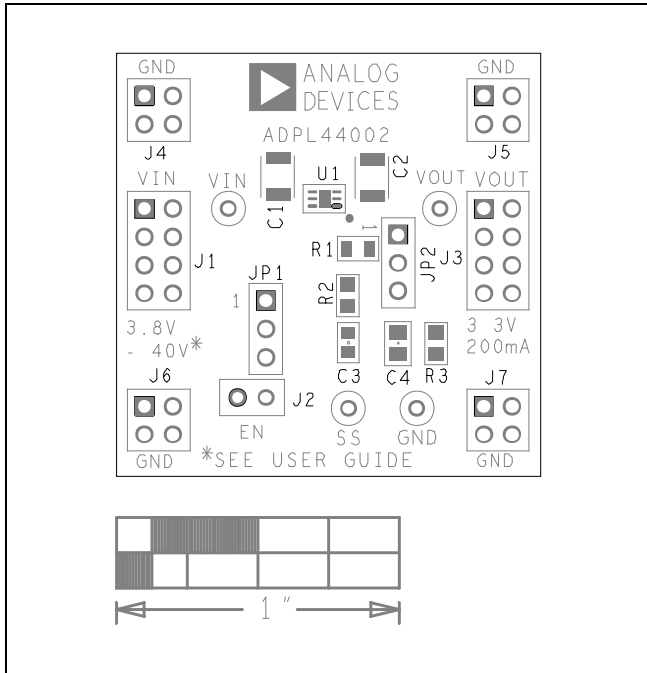

LCFSP Package Evaluation Board—Top Silkscreen

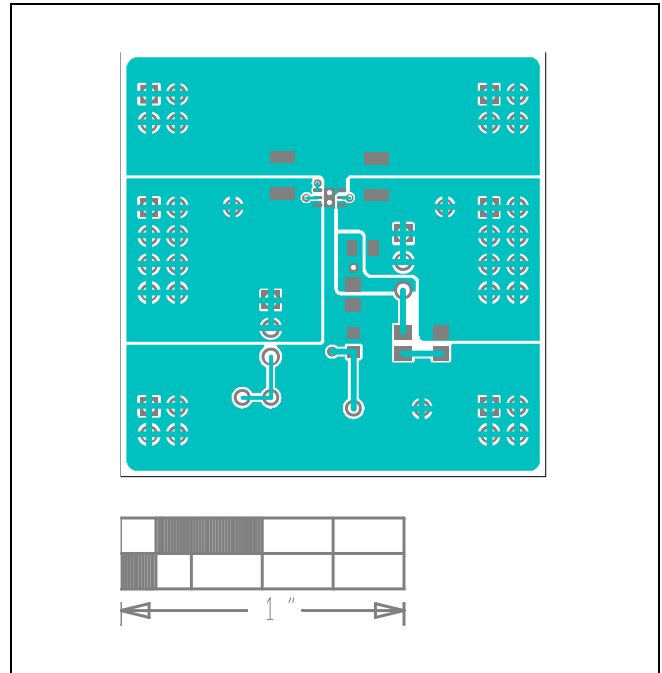

LCFSP Package Evaluation Board—Top

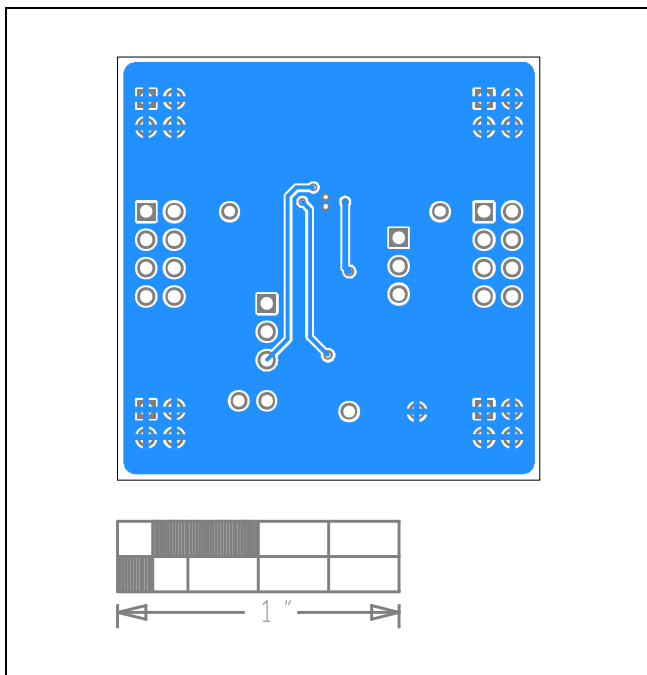

LCFSP Package Evaluation Board—Bottom

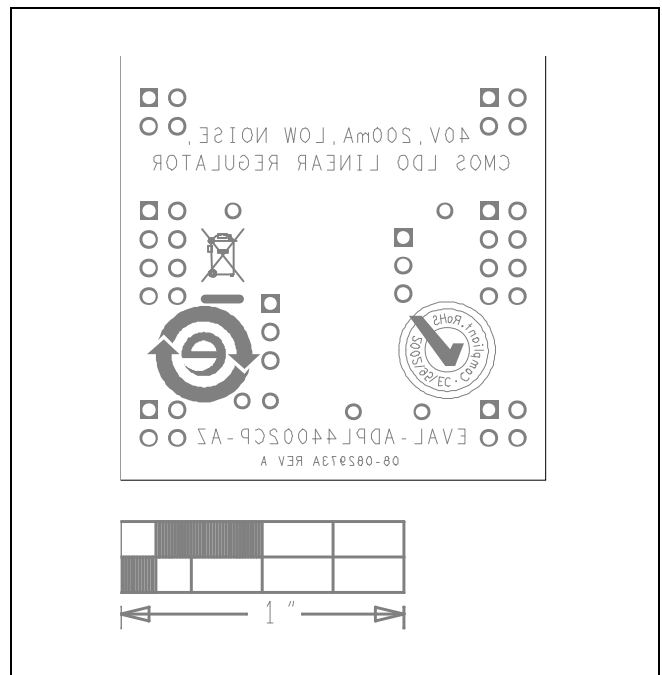

LCFSP Package Evaluation Board—Bottom Silkscreen

TSOT Package Evaluation Board PCB Layout

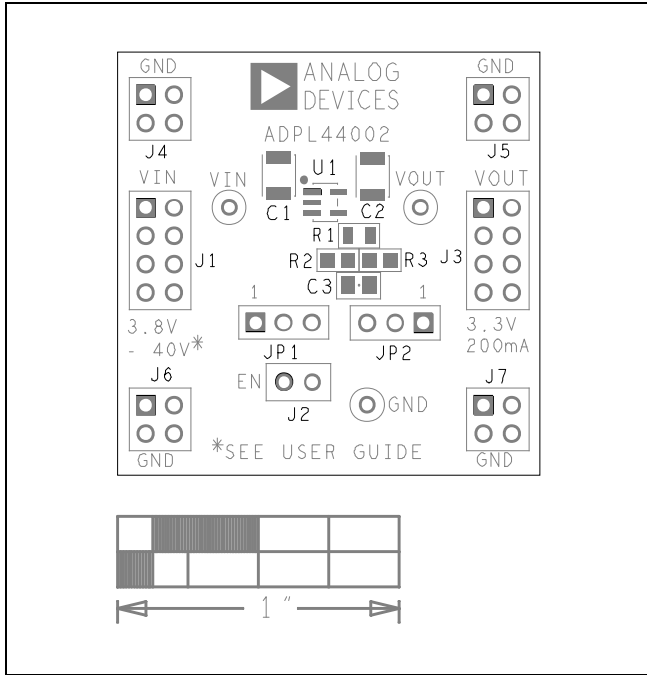

TSOT Package Evaluation Board—Top Silkscreen

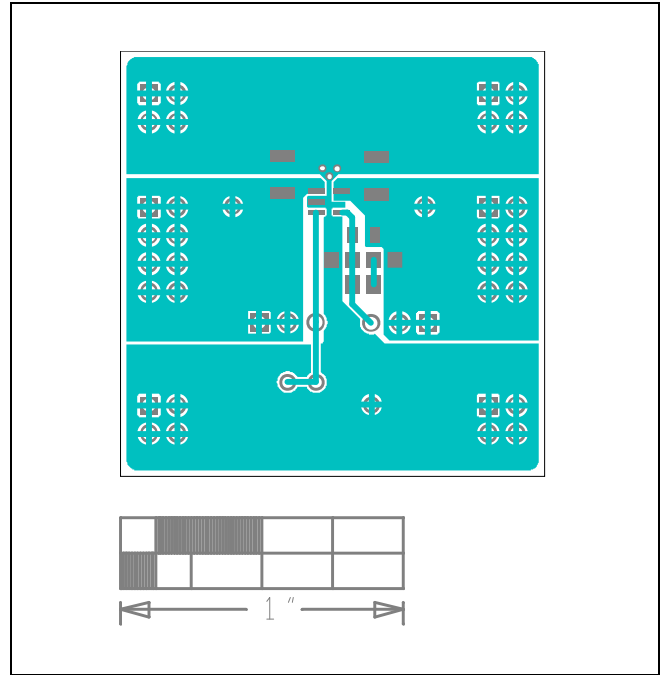

TSOT Package Evaluation Board—Top

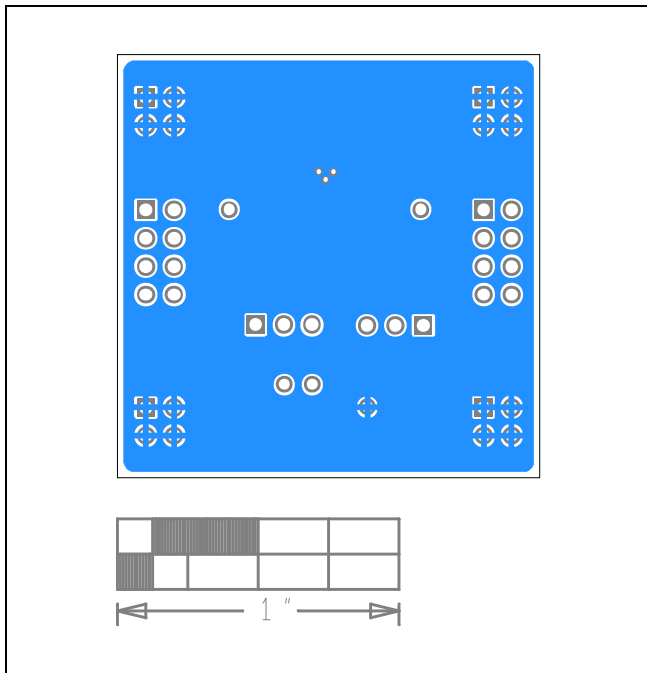

TSOT Package Evaluation Board—Bottom

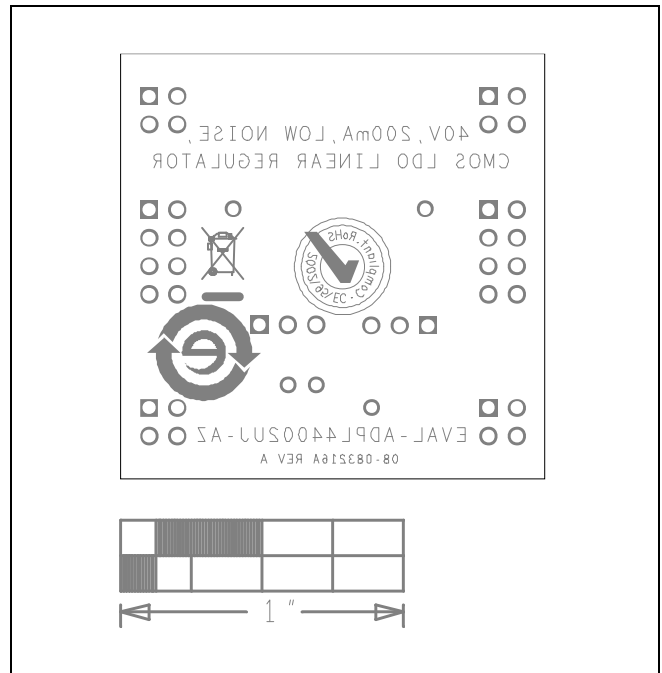

TSOT Package Evaluation Board—Bottom Silkscreen

Revision History

REVISION NUMBER	REVISION DATE	DESCRIPTION	PAGES CHANGED
0	09/24	Initial release	—

Notes

ALL INFORMATION CONTAINED HEREIN IS PROVIDED “AS IS” WITHOUT REPRESENTATION OR WARRANTY. NO RESPONSIBILITY IS ASSUMED BY ANALOG DEVICES FOR ITS USE, NOR FOR ANY INFRINGEMENTS OF PATENTS OR OTHER RIGHTS OF THIRD PARTIES THAT MAY RESULT FROM ITS USE. SPECIFICATIONS ARE SUBJECT TO CHANGE WITHOUT NOTICE. NO LICENSE, EITHER EXPRESSED OR IMPLIED, IS GRANTED UNDER ANY ADI PATENT RIGHT, COPYRIGHT, MASK WORK RIGHT, OR ANY OTHER ADI INTELLECTUAL PROPERTY RIGHT RELATING TO ANY COMBINATION, MACHINE, OR PROCESS, IN WHICH ADI PRODUCTS OR SERVICES ARE USED. TRADEMARKS AND REGISTERED TRADEMARKS ARE THE PROPERTY OF THEIR RESPECTIVE OWNERS. ALL ANALOG DEVICES PRODUCTS CONTAINED HEREIN ARE SUBJECT TO RELEASE AND AVAILABILITY.

Mouser Electronics

Authorized Distributor

Click to View Pricing, Inventory, Delivery & Lifecycle Information:

[Analog Devices Inc.:](#)

[EVAL-ADPL44002CP-AZ](#) [EVAL-ADPL44002UJ-AZ](#)