

## Evaluating the ADA4620-2 36 V, Precision, Low Noise, 16.5 MHz JFET Op Amp

### Features

- Full-featured evaluation board for the ADA4620-2
- Enables quick prototyping
- Provisions for user-defined circuit configuration
- Footprint provision for a photodiode for rapid evaluation
- Edge-mounted connectors and test point provisions

### General Description

The EVAL-ADA4620-2ARZ is an evaluation board designed for the ADA4620-2, a 36 V, precision, low noise, low offset drift, JFET op amp, available in an 8-lead SOIC package. The ADA4620-2 is preconfigured on this board as a unity-gain follower buffer. This four-layer evaluation board includes edge-mounted subminiature version A (SMA) connectors on both the inputs and outputs, facilitating efficient connections to test and measurement equipment or external circuits.

The evaluation board's ground plane, component placement, and power supply decoupling are optimized for maximum circuit flexibility and performance.

Additionally, the evaluation board features a variety of unpopulated resistor and capacitor pads, offering multiple choices and extensive flexibility for various application circuits and configurations, such as active loop filter, transimpedance amplifier (TIA), and charge amplifier. Furthermore, a combination of test points and edge-mounted SMA connectors are utilized for inputs, output, and signal measurements.

The evaluation board includes provisions for photodiode footprints, facilitating easy configuration of a TIA.

Additionally, the evaluation board offers provisions for constructing various types of filters. To select specific component values and design filters, refer to <https://tools.analog.com/en/filterwizard>.

The ADA4620-2 data sheet covers the specifications, details of device operation, and application circuit configurations and guidance. Consult the data sheet with this user guide for a better understanding of the device operation, especially when powering up the evaluation board for the first time.

### EV Kit Photo

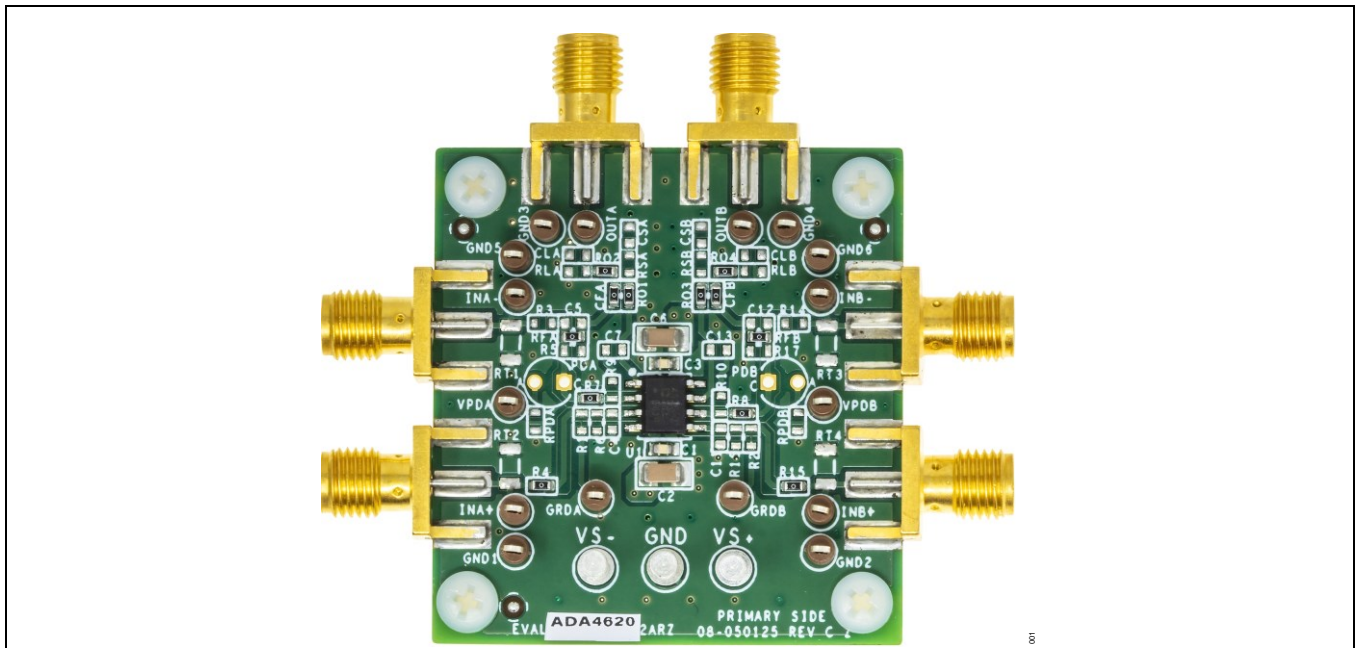

## Evaluation Board Quick Start Operation

### Overview

The following sections outline the basic prepopulated configuration of the EVAL-ADA4620-2ARZ required to test the basic functionality of the ADA4620-2. The board has provisions to make it highly configurable for many applications. The connectors available on the board provide an easy interface to various bench equipment.

### Equipment Needed

- A signal generator
- A dual output DC power supply
- An oscilloscope

### Amplifier Configuration

The EVAL-ADA4620-2ARZ board is configured in a noninverting configuration with a default gain of +1. Preinstalled resistors accommodate this configuration.

### Power Supply Connection

The terminal turret connectors, designated by VS+, VS-, and GND, power the evaluation board. Connect the DC power with the correct polarity and voltage. Reversing the polarity or applying overvoltage can permanently damage the evaluation board. Permissible supply voltages range from 4.5 V to 36 V for the single supply configuration and from  $\pm 2.25$  V to  $\pm 18$  V for dual supply configuration. Applying higher voltages may damage the amplifier. Decoupling capacitors of 10  $\mu$ F and 0.1  $\mu$ F come preinstalled on the board for immediate operation.

### Board Evaluation Connections

To start the initial evaluation, use the following connection procedure:

1. Ensure the power supply is off. Connect the positive supply, negative supply, and ground to the terminal turret connectors labelled VS+, VS-, and GND, respectively.
2. Ensure the signal generator output is disabled. Connect the signal source to INA+ or TP\_INA+, and set the signal source to high impedance (high Z) output.
3. Connect the output SMA connector (OUTA) to the oscilloscope.

### Power-Up Procedure

Follow this procedure to power up the board once the connection process (as discussed in the previous section) is complete. [Figure 1](#) illustrates the necessary connections.

1. Set the V+ supply to +15 V and the V- supply to -15 V.
2. Turn on the power supply. The typical supply current of the ADA4620-2 is 1.3 mA per amplifier.
3. Configure the signal source to output a 10 kHz sine wave with a 5 V peak-to-peak amplitude with 0 V DC offset.
4. Enable the signal source. The oscilloscope must show a 5 V peak-to-peak sine wave at the output with the same frequency of the input signal.

### Transimpedance Amplifier (TIA) Configuration

The low input bias current and low input capacitance of the ADA4620-2 amplifier makes it a good choice for transimpedance configurations. The evaluation board has an on-board provision for a photodiode (radial package). When operating in a TIA configuration, a bias voltage can be applied to the VPD to bias the anode of the photodiode. If no bias voltage needs to be applied, install a 0  $\Omega$  resistor at the R5 footprint. For this TIA configuration, install the

photodiode at the PD footprint and connect a feedback resistor at the RF1 footprint. A feedback capacitor at the CF1 footprint can be added for stability of the circuit.

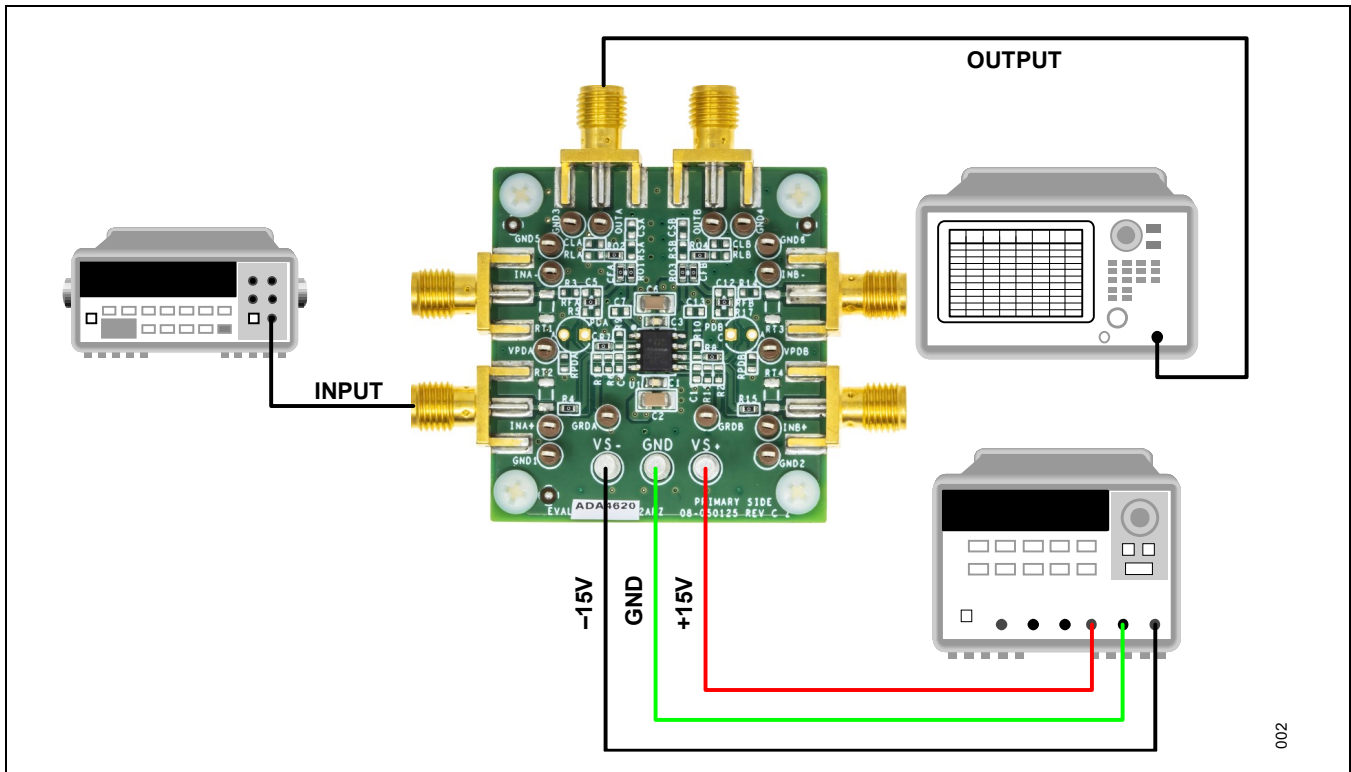
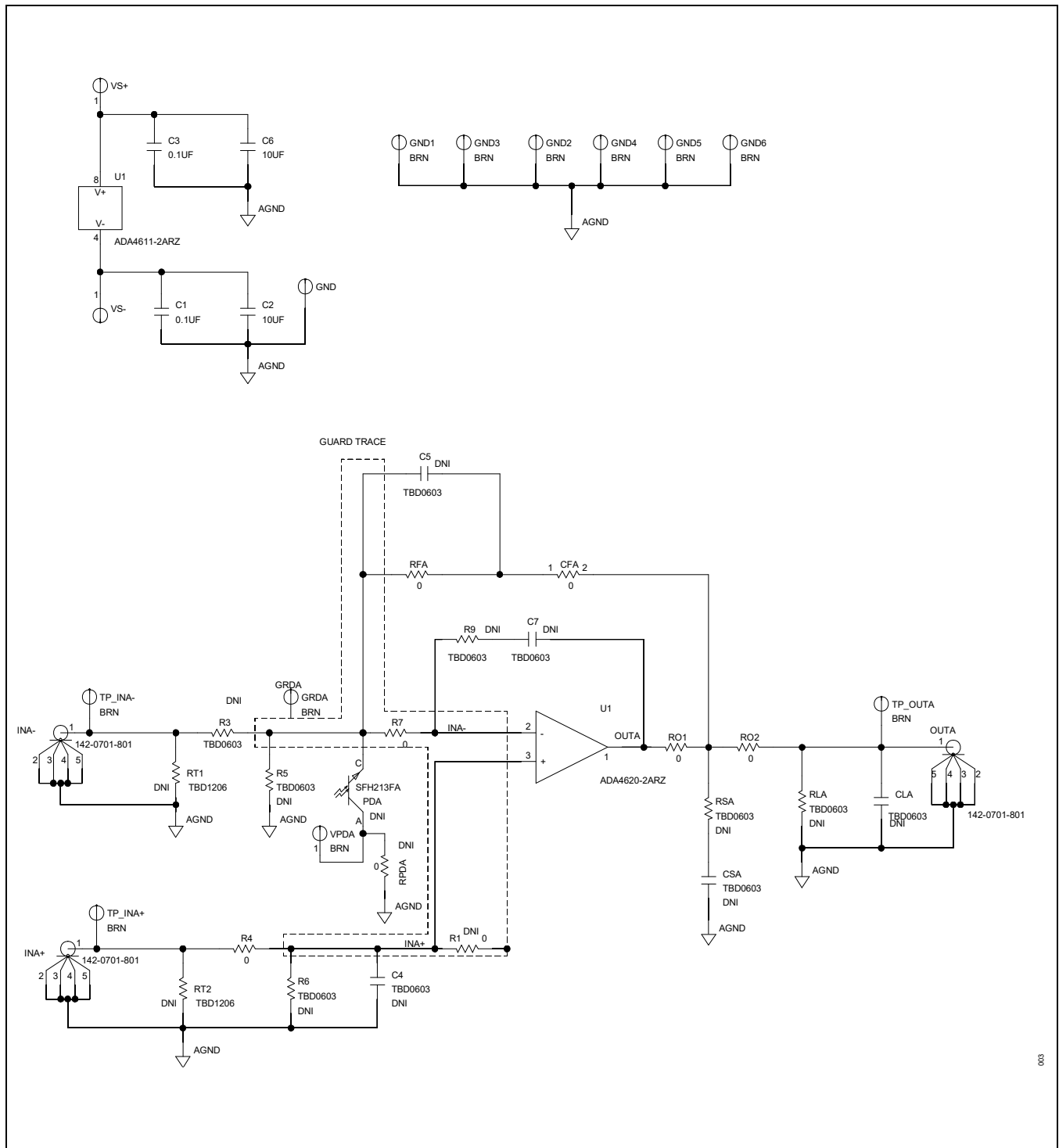

Figure 1. ADA4620-2 EV Board Connection

## Bill of Materials

Quantity	Reference Designator	Description	Manufacturer	Part Number
<b>The following components are installed on the PCB.</b>				
2	C1, C3	0.1 $\mu$ F capacitor ceramic X7R C0603	Vishay	VJ0603Y104KXAAC31X
2	C2, C6	10 $\mu$ F capacitor ceramic X5R C1206H71	TDK	C3216X5R1H106K160AB
12	CFA, CFB, R4, R7, R8, R15, RFA, RFB, RO1, RO2, RO3, RO4	0 R resistor film surface-mounted device R0603	Panasonic	ERJ-3GEY0R00V
3	GND, VS+, VS-	Connector-PCB solder terminal turrets	Mill-Max	2501-2-00-80-00-00-07-0
16	GND1, GND2, GND3, GND4, GND5, GND6, GRDA, GRDB, TP_INA+, TP_INA, TP_INB+, TP_INB, TP_OUTA, TP_OUTB, VPDA, VPDB	Connector-PCB test point brown	Keystone Electronics	5115
6	INA+, INA-, INB+, INB-, OUTA, OUTB	Connector-PCB coaxial SMA end launch	Cinch Connectivity Solutions	142-0701-801
1	U1	IC-ADI low noise, precision, JFET operational amplifier, SOIC 8	Analog Devices	ADA4620-2ARZ
<b>The following components are mechanical parts.</b>				
4	NA	Standoff, nylon hex female 6.35 MM O.D, 4-40 thread, 1/2 inch long	Keystone	1902C
4	NA	Screw, machine nylon pan head Phillips 4-40 thread, 1/4 inch long	B&F Fastener Supply	NY PMS 440 0025 PH
<b>The following components are NOT installed by default.</b>				
10	C4, C5, C7, C11, C12, C13, CLA, CLB, CSA, CSB	C0603	NA	NA
2	PDA, PDB	Photodiode	Osram Opto Semiconductors	SFH213FA
4	R1, R2, RPDA, RPDB	0R resistor film surface-mounted device 0603 1 W/10 W R0603	Panasonic	ERJ-3GEY0R00V
12	RT1, RT2, RT3, RT4	R1206	NA	NA
4	R3, R5, R6, R9, R10, R14, R16, R17, RLA, RLB, RSA, RSB	R0603	NA	NA

ADA4620-2 EV Schematic



003

ADA4620-2 EV Schematic (continued)

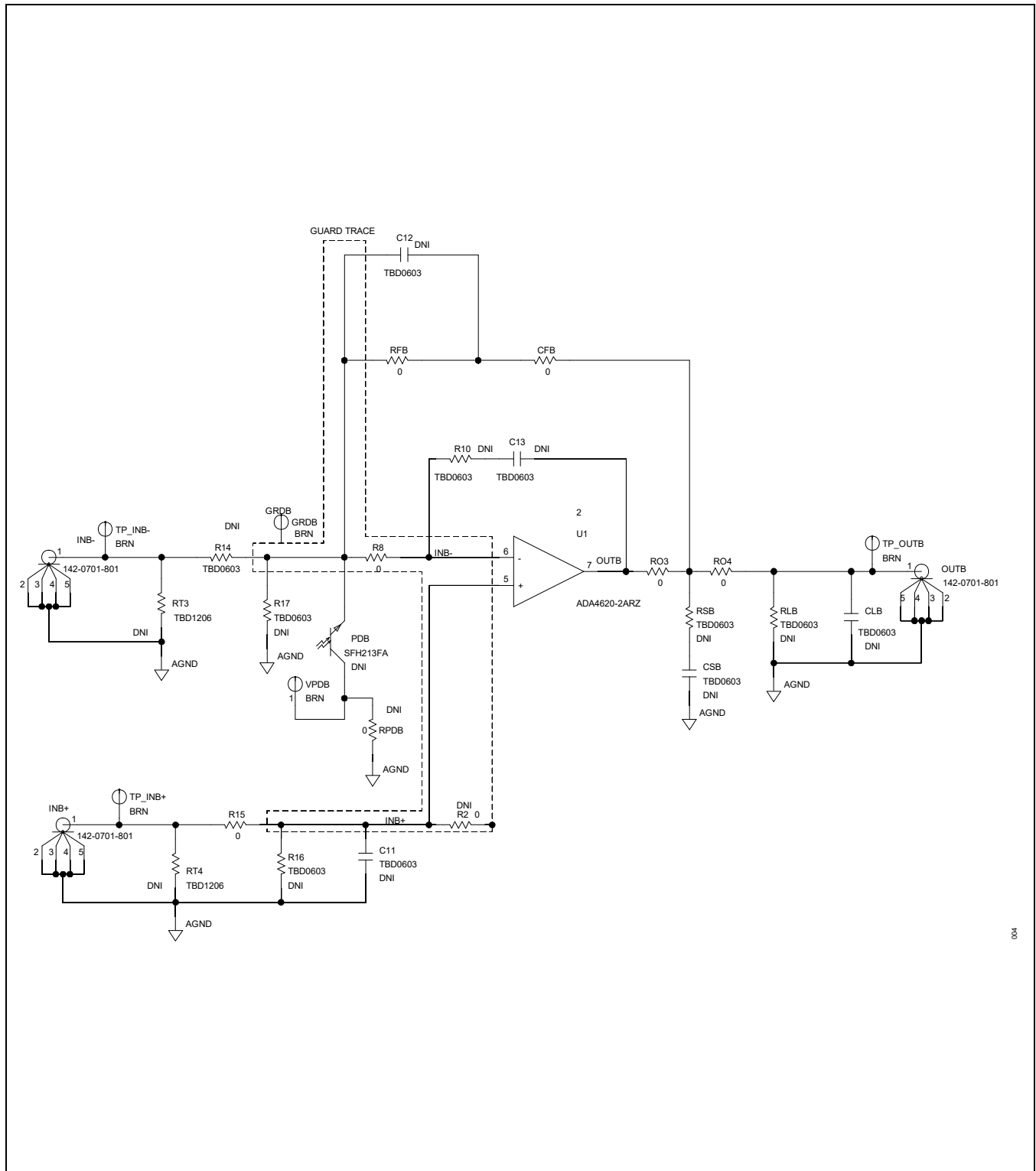

ADA4620-2 EV PCB Layout

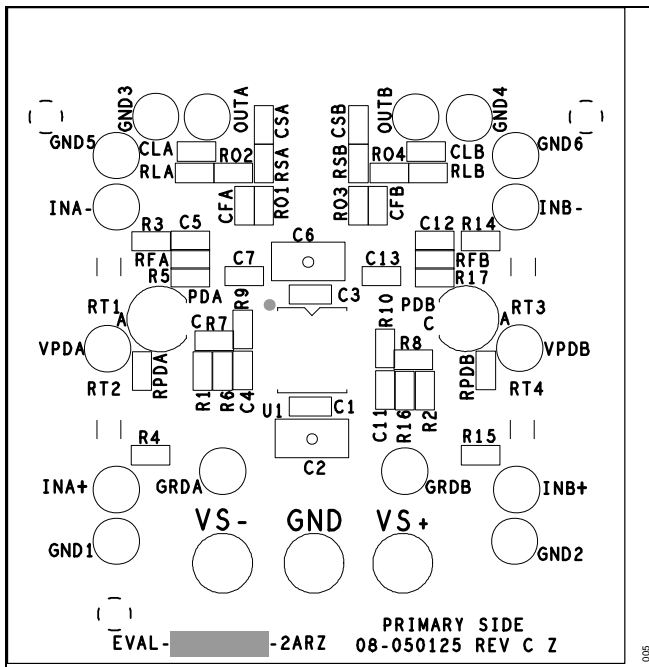

ADA4620-2 EV Component Placement Guide—Top Silkscreen

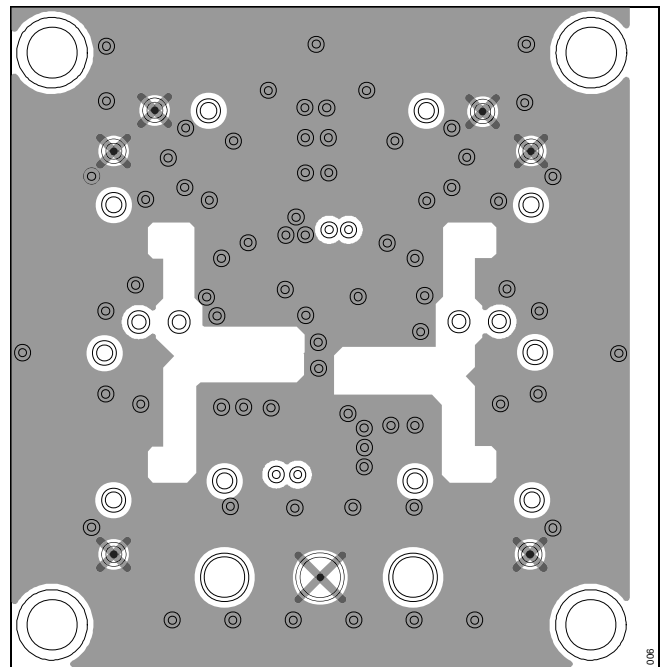

ADA4620-2 EV PCB Layout—Layer 2

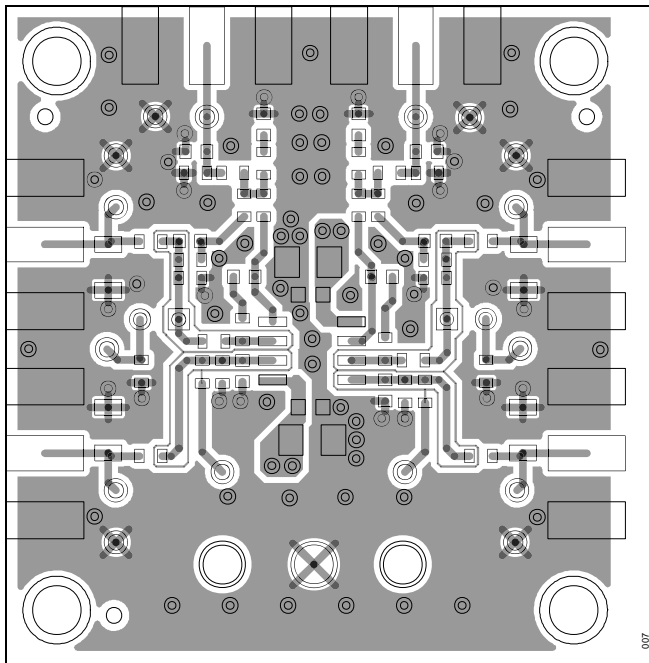

ADA4620-2 EV Kit PCB Layout—Top

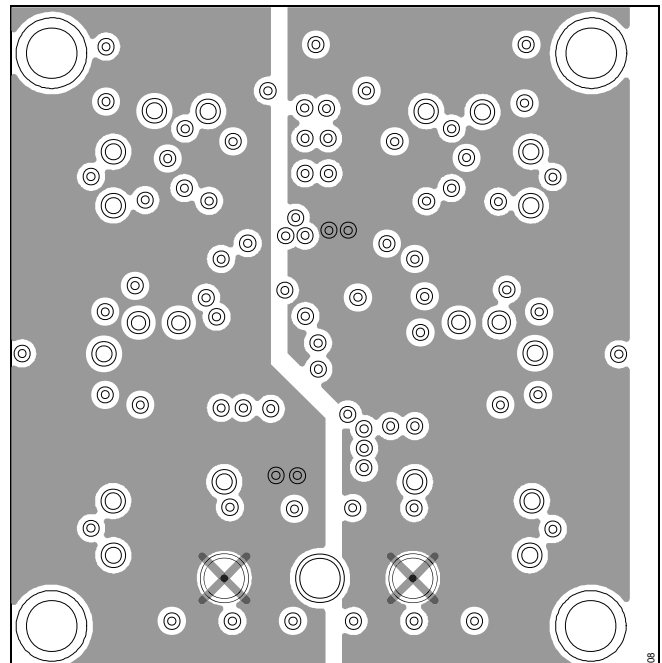

ADA4620-2 EV PCB Layout—Layer 3

ADA4620-2 EV PCB Layout (continued)

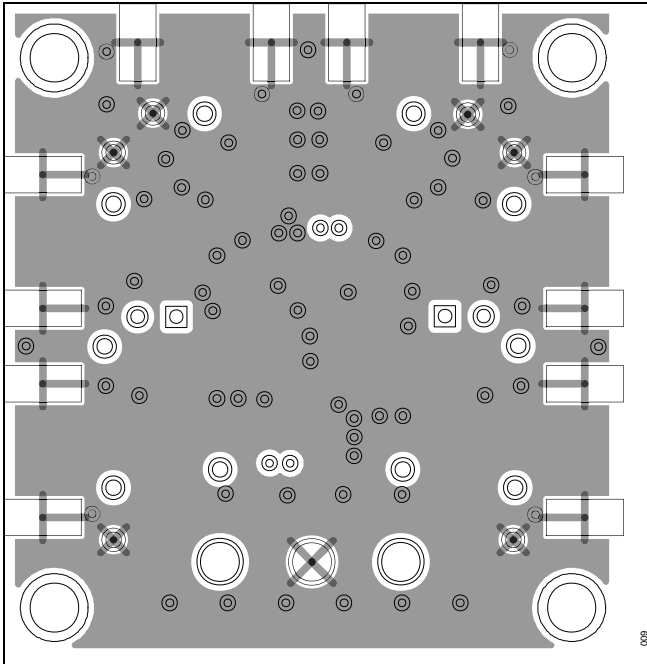

ADA4620-2 EV PCB Layout—Bottom

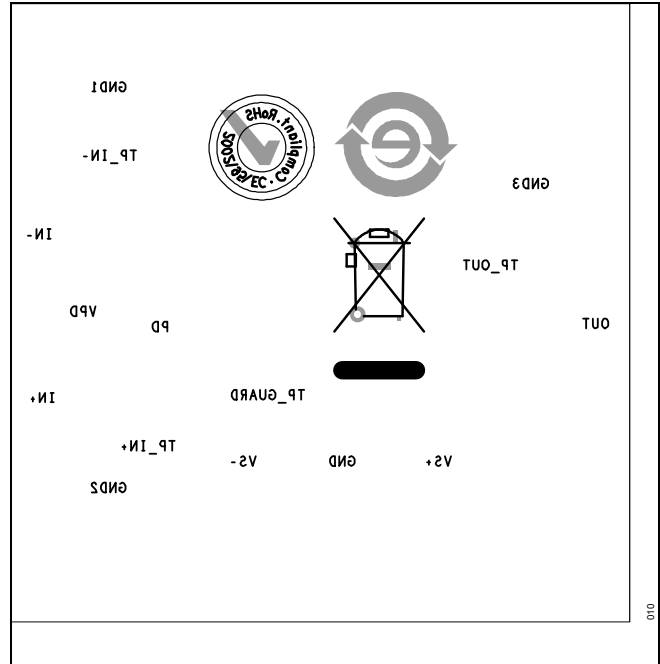

ADA4620-2 EV Component Placement Guide—Bottom Silkscreen



### Revision History

REVISION NUMBER	REVISION DATE	DESCRIPTION	PAGES CHANGED
0	10/24	Initial release	—

## Notes

ALL INFORMATION CONTAINED HEREIN IS PROVIDED “AS IS” WITHOUT REPRESENTATION OR WARRANTY. NO RESPONSIBILITY IS ASSUMED BY ANALOG DEVICES FOR ITS USE, NOR FOR ANY INFRINGEMENTS OF PATENTS OR OTHER RIGHTS OF THIRD PARTIES THAT MAY RESULT FROM ITS USE. SPECIFICATIONS ARE SUBJECT TO CHANGE WITHOUT NOTICE. NO LICENSE, EITHER EXPRESSED OR IMPLIED, IS GRANTED UNDER ANY ADI PATENT RIGHT, COPYRIGHT, MASK WORK RIGHT, OR ANY OTHER ADI INTELLECTUAL PROPERTY RIGHT RELATING TO ANY COMBINATION, MACHINE, OR PROCESS, IN WHICH ADI PRODUCTS OR SERVICES ARE USED. TRADEMARKS AND REGISTERED TRADEMARKS ARE THE PROPERTY OF THEIR RESPECTIVE OWNERS. ALL ANALOG DEVICES PRODUCTS CONTAINED HEREIN ARE SUBJECT TO RELEASE AND AVAILABILITY.

# Mouser Electronics

Authorized Distributor

Click to View Pricing, Inventory, Delivery & Lifecycle Information:

[Analog Devices Inc.:](#)

[EVAL-ADA4620-2ARZ](#)