User Guide for ADA4342-2 Evaluation Board

General Description

The EVAL-ADA4352-2EBZ is designed to evaluate the ADA4352-2, a compact, monolithic, dual-channel, precision, programmable gain transimpedance amplifier (PGTIA) that integrates four current-to-voltage gain selections per channel, in which the gain is programmable using two logic pins per channel, offered in a 3 mm x 3 mm x 0.75 mm 16-lead lead frame chip scale package (LFCSP).

The EVAL-ADA4352-2EBZ is a four-layer printed circuit board with dimensions of 2.9 in x 2.25 in. [Figure 1](#) and [Figure 2](#) show the board's front and back view. The evaluation board comes populated with key components to run and evaluate the board quickly and easily. It also allots unpopulated resistor/capacitor provisions on its input and output stages, allowing to install components with user-defined values for circuits such as a low pass filter or voltage divider.

The evaluation board is accessible through SMA female socket edge mounts to directly connect test equipment to the inputs and outputs of both channels, as well as the gain switch control pins. It also comes with an unpopulated photodiode slot on each channel, allowing for quick prototyping.

Features and Benefits

- Full featured evaluation board for the ADA4352-2, a small, dual-channel, complete PGTIA and AFE solution in a 3 mm x 3 mm 16-lead LFCSP package.
- Enables quick prototyping.
- Provision for PGTIA logic control through two-pin headers or SMA connectors.
- Provisions for user-defined circuit configuration, including provisions for photodiodes.
- Available edge-mounted SMA connectors and test points to easily connect with test equipment.

[Ordering Information](#) appears at end of data sheet.

Evaluation Board Kit Contents

- One populated EVAL-ADA4352-2EBZ evaluation board
- Six shunt connectors (four usable, two extra)

Document Needed

- ADA4352-2 data sheet

Equipment Needed

Hardware

- Digital multimeter (Agilent 34401A)
- Power supplies (Agilent E3631)
- Source meter (Keithley 2400) for current source input
- High precision voltage source (Datel DVC-8500) for voltage source input

Cables and Components

- SMA (male) to BNC connector (male) cables
- BNC connector (female) to dual banana plug adapter
- Banana to test clip cables
- SMA 50 Ω termination

Evaluation Board Photos

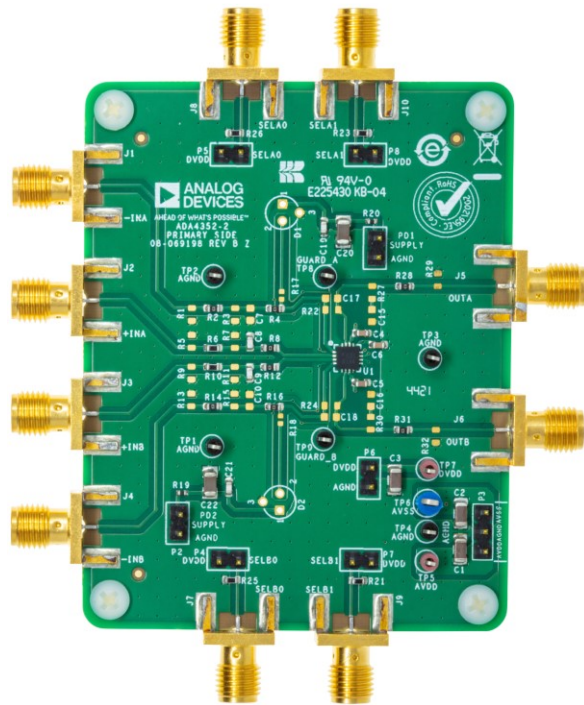

16

Figure 1. EVAL-ADA4352-2EBZ Digital Photograph (Top View)

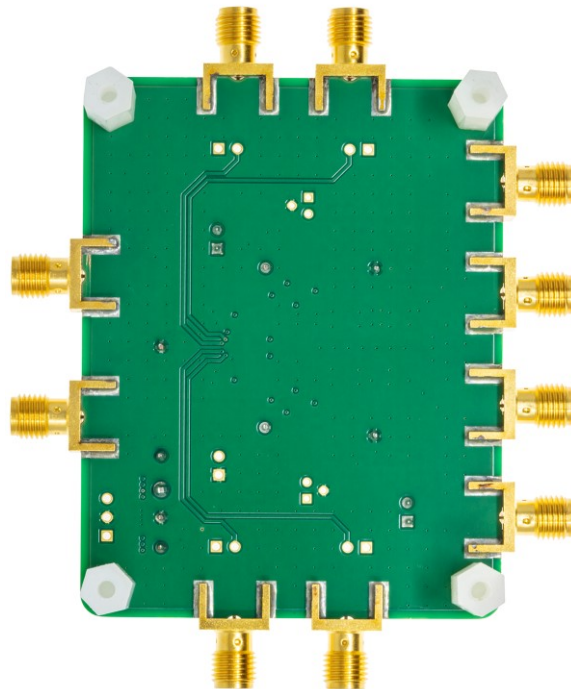

17

Figure 2. EVAL-ADA4352-2EBZ Digital Photograph (Bottom View)

TABLE OF CONTENTS

General Description 1

Features and Benefits 1

Evaluation Board Kit Contents 1

Document Needed 1

Equipment Needed 1

Evaluation Board Photos 2

Evaluation Board Hardware Guide 4

 Power Supplies 5

 Supplying Through Pin Headers 5

 Supplying Through Test Points 5

 Gain Switch Control 6

 Switch Control Using SMA Connectors 6

 Switch Control Using Pin Headers 6

 Gain Setting 7

 Photodiode Circuit 8

Evaluation Board Quick Start Guide 9

Evaluation Board Schematic and Artwork 11

Ordering Information 13

Revision History 14

Evaluation Board Hardware Guide

The EVAL-ADA4352-2EBZ provides features for easier evaluation and operation. *Figure 3* and *Table 1* show the key components of the evaluation board as well as the designators. This section discusses how to access and operate these features.

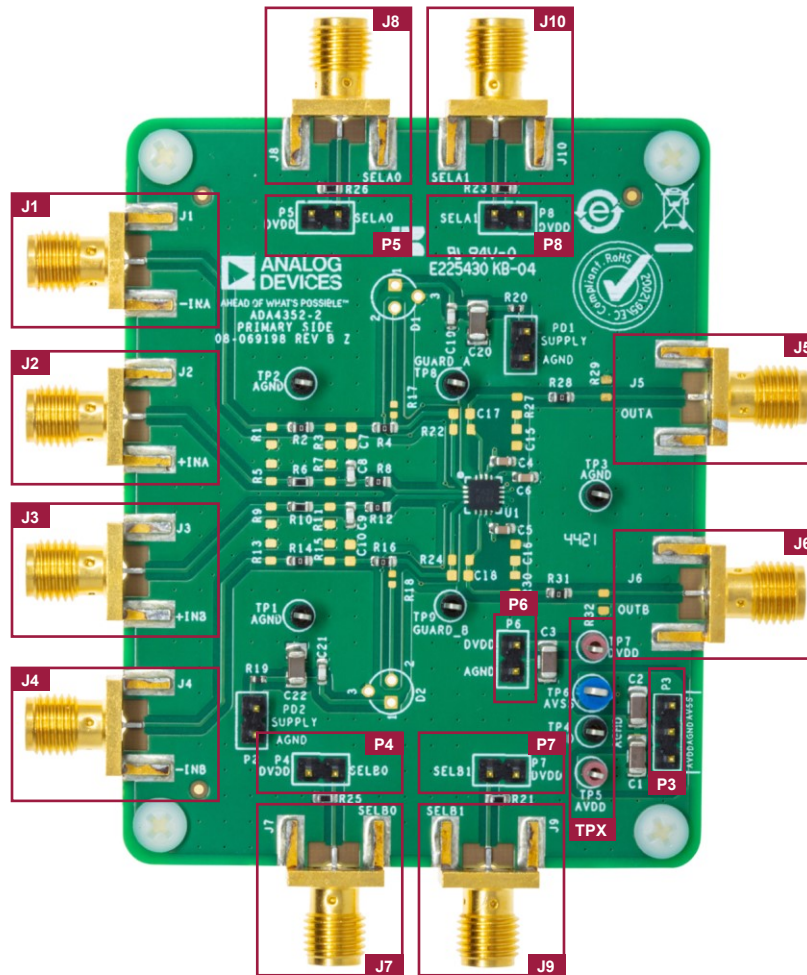

Figure 3. Designator Map of EVAL-ADA4352-2EBZ

Table 1. Designator Lookup Table

| Designator | Description |
|------------|--|
| J1 | Inverting input terminal on channel A amplifier |
| J2 | Noninverting input terminal on channel A amplifier |
| J3 | Noninverting input terminal on channel B amplifier |
| J4 | Inverting input terminal on channel B amplifier |
| J5 | Output of channel A amplifier |
| J6 | Output of channel B amplifier |
| J7 | SMA input used to set the value of SW SEL0 B to digital 0 or 1 |
| J8 | SMA input used to set the value of SW SEL0 A to digital 0 or 1 |
| J9 | SMA input used to set the value of SW SEL1 B to digital 0 or 1 |
| J10 | SMA input used to set the value of SW SEL1 A to digital 0 or 1 |

| | |
|-----|---|
| P3 | Analog power supplies -3 pin connector (from top to bottom, AVSS, AGND, and AVDD) |
| P4 | Jumper used to manually set the value of SW SEL0 B to digital 0 or 1 |
| P5 | Jumper used to manually set the value of SW SEL0 A to digital 0 or 1 |
| P6 | Digital power supplies -2 pin connector (from top to bottom, DVDD and AGND) |
| P7 | Jumper used to manually set the value of SW SEL1 B to digital 0 or 1 |
| P8 | Jumper used to manually set the value of SW SEL1 A to digital 0 or 1 |
| TPx | Test points that connect to the digital and analog power supplies |

Power Supplies

The ADA4352-2 uses two supplies:

- (1) Analog supply, which powers up the PGTIA itself, thereby setting the rails.
- (2) Digital supply, which powers up the switches for both channels A and B.

The two supplies share a common ground plane. [Table 2](#) shows the supply range accepted by the device. Refer to the data sheet for absolute maximum ratings.

The EVAL-ADA4352-2EBZ provides two ways to power up the part:

- (1) Through pin headers.
- (2) Through test points.

Table 2. Analog and Digital Supply Ranges for EVAL-ADA4352-2EBZ

| Supply | Supply Range | |
|---------|--------------|---------------------|
| Analog | AVDD to AVSS | 2.7 V to 5.5 V |
| | AVSS | -0.5 V to 0 V (GND) |
| Digital | DVDD to DVSS | 1.62 V to 5.5 V |
| | DVSS | 0 V (GND) |

Supplying Through Pin Headers

The evaluation board provides a three-pin header for analog supplies and a two-pin header for digital supplies. For proper connection, see P3 (for analog supplies) and P6 (for digital supplies) in [Figure 3](#) and [Table 1](#).

Supplying Through Test Points

Though intended for measuring the supply voltages, the provided test points can also be used to access the supply planes. See TPx in [Figure 3](#) for its location and [Table 3](#) for proper connection.

Table 3. Designated Test Points for Analog and Digital Supplies

| Power Supply | Test Points |
|--|-----------------------|
| Analog positive supply voltage (AVDD) | TP5 |
| Analog negative supply voltage (AVSS) | TP6 |
| Digital positive supply voltage (DVDD) | TP7 |
| Digital negative supply voltage (DVSS) | N/A (soldered to GND) |

Gain Switch Control

The ADA4352-2 has two channels, A and B. Each channel is connected to four internal feedback paths, each with a unique corresponding gain setting that can each be accessed by toggling the switch control pins, SW SEL0 A and SW SEL1 A for channel A, and SW SEL0 B and SW SEL1 B for channel B, to either low or high. [Figure 4](#) shows the simplified diagram of a single channel of the ADA4352-2.

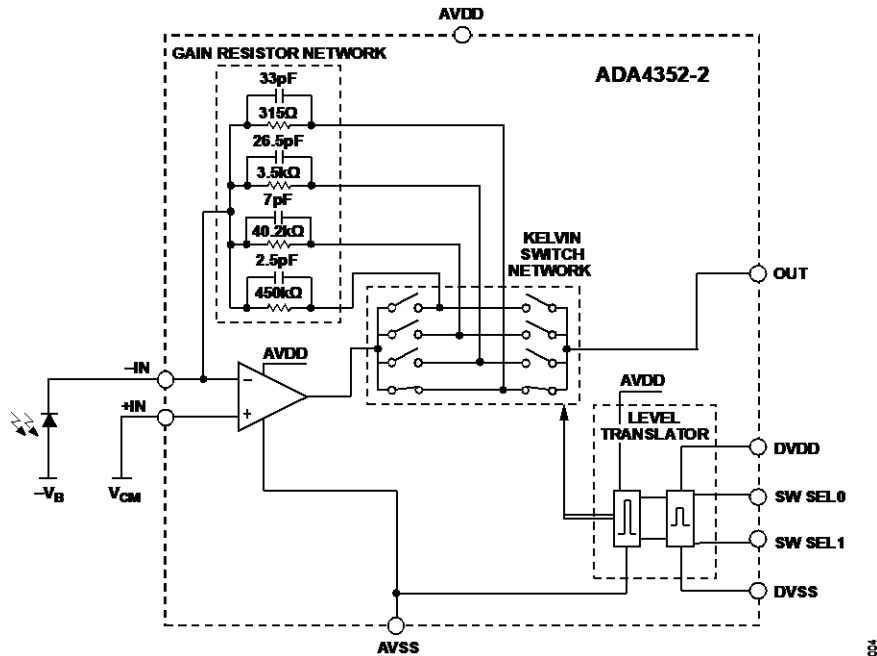

Figure 4. Simplified Block Diagram of an ADA4352-2 Channel

The EVAL-ADA4352-2EBZ provides two methods of controlling the gain switch:

- (1) Through pin headers.
- (2) Through the mounted SMA connectors.

Moreover, the ADA4352-2 has a pull-down feature on each of its switch control pins that automatically sets the switch control input to LOW when connections to the switch control pins are left open. [Table 5](#) details which feedback path is active based on the switch control's state.

Switch Control Using SMA Connectors

The evaluation board comes with two mounted SMA female connectors for each channel. These may be used to connect a power supply or any other voltage source, such as pulse generators or batteries, to the switch control pins. The SMA connectors for channel A are J8 (for SW SEL A0) and J10 (for SW SEL A1), and for channel B, they are J7 (for SW SEL B0) and J9 (for SW SEL B1), as seen in [Figure 3](#). For the required voltage level to toggle the switches to HIGH or LOW input, see [Table 4](#).

Table 4. Threshold Voltage for Digital Input Pins

| Threshold Voltage | Minimum | Maximum |
|--------------------------|--------------|--------------|
| Input high voltage (VIH) | DVDD – 0.7 V | — |
| Input low voltage (VIL) | — | DVSS + 0.5 V |

Switch Control Using Pin Headers

The EVAL-ADA4352-2EBZ provides pin headers which, when shorted, connect to the DVDD supply, changing the switch state from LOW to HIGH. The pin headers for channel A are P5 (SW SEL0 A) and P8 (SW SEL1 A), as seen in [Figure 3](#), while the pin headers for channel B are P4 (SW SEL0 B) and P7 (SW SEL1 B).

Gain Setting

As mentioned, each channel of the ADA4352-2 has four internal feedback paths and each contains an internal resistor (315 Ω, 3.5 kΩ, 40.2 kΩ, and 450 kΩ), which declares the gain of the channel. To select a specific gain setting, a correct combination of SW SEL0 x and SW SEL1 x switch states (with “x” pertaining to the channel of interest) must be employed. [Table 5](#) presents the truth table for accessing specific gain settings.

See the schematic in [Figure 8](#) for the circuit.

Table 5. Switch Control and Gain Setting

| Channel | Default Gain Setting (Feedback Path) | Gain Control Switch 1 State (SW SEL1 x) P8 or J10 for A; P7 or J9 for B | Gain Control Switch 0 State (SW SEL0 x) P5 or J8 for A; P4 or J7 for B | Switch Setting Methods | |
|---------|--------------------------------------|--|---|---|--|
| | | | | Pin Header Connection | SMA Connection |
| A | 315 Ω | Low | Low | Leave P8 and P5 open. | Set the voltage level to less than DVSS + 0.5 V for J10 and J8. |
| | 3.5 kΩ | Low | High | Leave P8 open. Install jumper at P5. | Set the voltage level to less than DVSS + 0.5 V for J10. Set the voltage level to greater than DVDD - 0.7 V for J8. |
| | 40.2 kΩ | High | Low | Install jumper at P8. Leave P5 open. | Set the voltage level to greater than DVDD - 0.7 V for J10. Set the voltage level to less than DVSS + 0.5 V for J8. |
| | 450 kΩ | High | High | Install jumper at P8 and P5. | Set the voltage level to greater than DVDD - 0.7 V for J10 and J8. |
| B | 315 Ω | Low | Low | Leave P7 and P4 open. | Set the voltage level to less than DVSS + 0.5 V for J9 and J7. |
| | 3.5 kΩ | Low | High | Leave P7 open. Install jumper at P4. | Set the voltage level to less than DVSS + 0.5 V for J9. Set the voltage level to greater than DVDD - 0.7 V for J7. |
| | 40.2 kΩ | High | Low | Install jumper at P7. Leave P4 open. | Set the voltage level to greater than DVDD - 0.7 V for J9. Set the voltage level to less than DVSS + 0.5 V for J7. |
| | 450 kΩ | High | High | Install jumper at P7 and P4. | Set the voltage level to greater than DVDD - 0.7 V for J9 and J7. |

Photodiode Circuit

The EVAL-ADA4352-2EBZ comes with on-board layout provision for a simple photodiode (PD) circuit. The unpopulated D1 (for channel A) and D2 (for channel B) slots allow for three-pin photodiodes on TO packages or fiber optic receivers. The two-pin headers P1 and P2 can be used to connect the photodiode to external supply. The PD circuit can be connected to the input by installing a 0 Ω resistor to R17 (for channel A) and R18 (for channel B). *Figure 5* shows their location within the board.

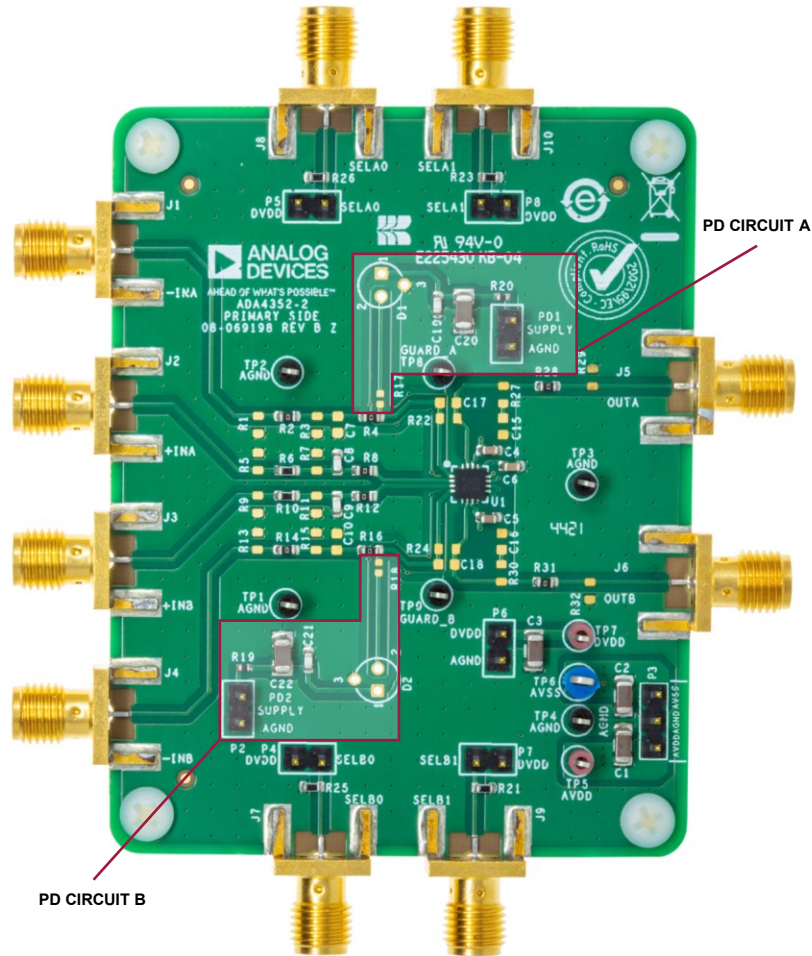

Figure 5. Photodiode Circuits of the EVAL-ADA4352-2EBZ

005

Evaluation Board Quick Start Guide

Follow these steps to quickly get the EVAL-ADA4352-2EBZ up and running using a current source as an input, as well as perform quick functionality tests for it. [Figure 7](#) shows the transimpedance amplifier circuit used for this quick start.

1) Configure and connect the power supplies to be used.

- For this quick start, use the following configuration:
 - Analog positive supply voltage (AVDD): +2.5 V, 0.1 A
 - Analog negative supply voltage (AVSS): -2.5 V, 0.1 A
 - Digital positive supply voltage (DVDD): +1.8 V, 0.1 A
- Connect the supplies to the designated test points, as seen on the evaluation board silk screen from [Figure 6](#).

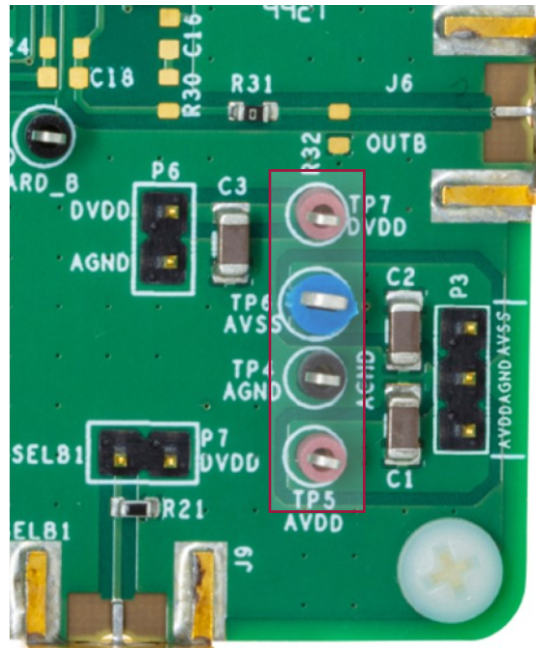

Figure 6. Power Supply Pins (from Top to Bottom: DVDD, AVSS, AGND, AVDD)

- See the “Power Supplies” section for the different ways to power up the board, [Table 2](#) shows the analog and digital supplies operation range.
- 2) Configure the source meter for the input; set it as current source.
- For this quick start, set the current source to 500 μ A (if connecting to lower gain resistors) or 4 μ A (if connecting to higher gain resistors). See [Table 6](#) for the expected outputs of each setting.
- 3) Connect the current source to the inverting pin of the amplifier through the SMA inputs.
- For channel A, connect to J1.
 - For channel B, connect to J4.
- 4) Select the desired gain for each channel by configuring the switch controls (SW SEL0 x and SW SEL1 x).
- For this quick start, leave the switches at default state (open; no shunt connectors installed on P4, P5, P7, and P8). This is configured on a quick functionality test, as seen in [Table 6](#).
 - See [Table 5](#) under the “Gain Switch Control” section for details on how to select and set the gain states for each channel.
- 5) Ground the noninverting input pin of the amplifier using a 0 Ω or 50 Ω SMA termination.
- For channel A, install at J2.
 - For channel B, install at J3.

6) Connect a digital multimeter to the board's SMA output.

- For channel A, connect to J5.
- For channel B, connect to J6.

7) Enable the sources as follows:

- Turn on the power supply for the analog and digital supplies.
- Turn on the current source for the input.
- Toggle the switch control (SW SEL0 x and SW SEL1 x) to HIGH as needed, following the functionality test suggested in [Table 6](#).

8) Record the measured output, as shown in the digital multimeter.

- [Table 6](#) shows the current input and expected output.

[Figure 9](#) shows the full physical setup of one of the ways to get the EVAL-ADA4352-2EBZ up and running. Following this quick start guide should give results, as seen in [Table 5](#). Values should be +/-10% of the expected output, as following.

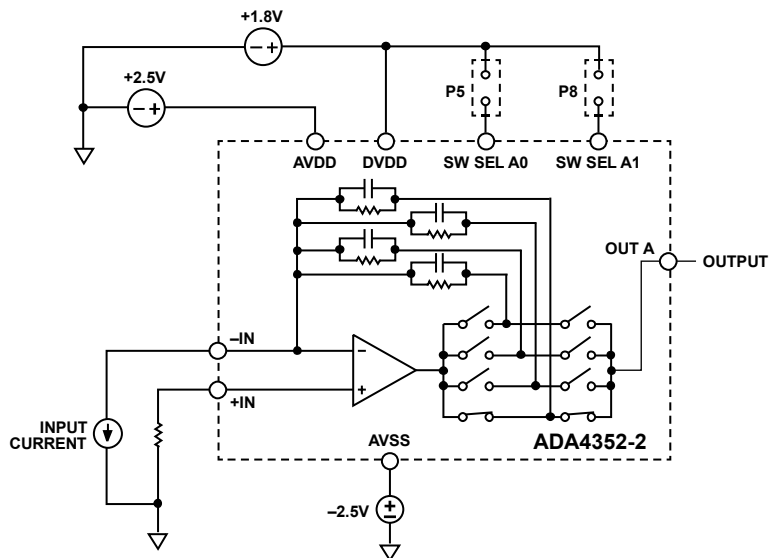

Figure 7. EVAL-ADA4352-2EBZ Quick Start Transimpedance Amplifier Circuit

Table 6. Expected Output

| Input Current | SW_SELx1 P8 or J10 for A; P7 or J9 for B | SW_SELx0 P5 or J8 for A; P4 or for B | Corresponding Gain Resistor | Expected Output (V) |
|---------------|--|--|--------------------------------|---------------------|
| 500 μ A | 0 | 0 | 315 Ω | 0.16 |
| 500 μ A | 0 | 1 | 3.5 k Ω | 1.76 |
| 4 μ A | 1 | 0 | 40.2 k Ω | 0.16 |
| 4 μ A | 1 | 1 | 450 k Ω | 1.80 |

For further understanding of the evaluation board's circuit, see [Figure 8](#) for the whole schematic of the board.

Evaluation Board Schematic and Artwork

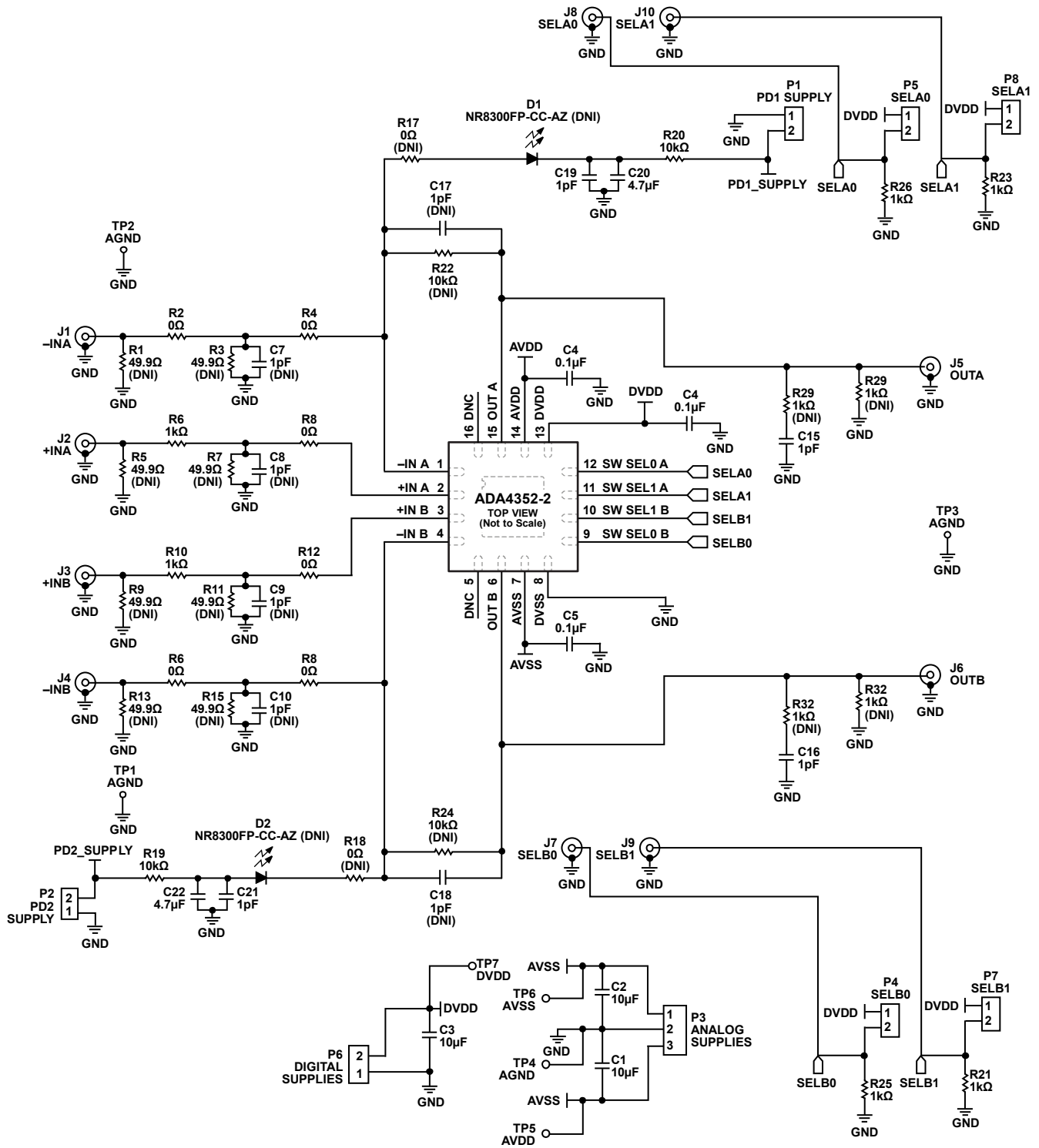
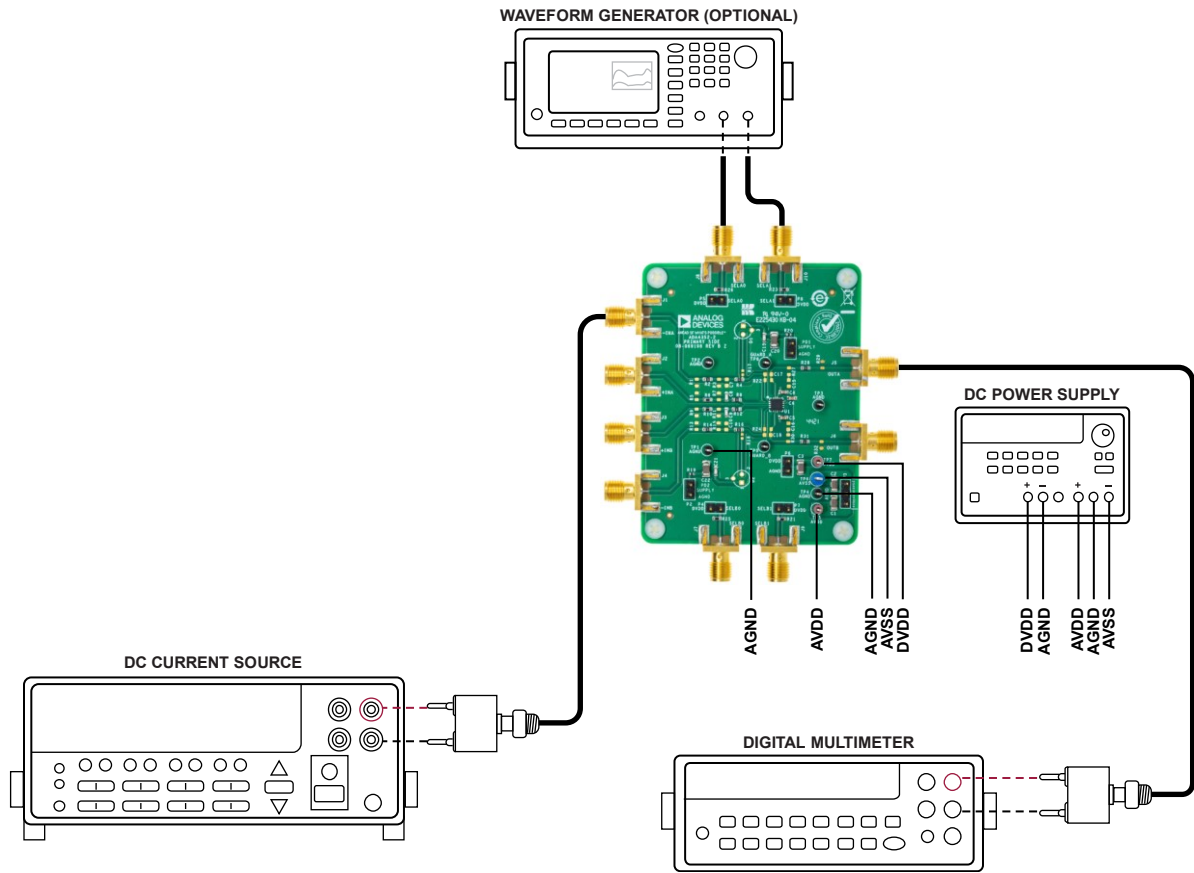

Figure 8. EVAL-ADA4352-2EBZ Full Schematic



009

Figure 9. EVAL-ADA4352-2EBZ Full Setup Example

Ordering Information

Table 7. Bill of Materials

| Quantity | Designator | Description | Manufacturer and Part Number |
|----------|---|---|---|
| 1 | ADA4352-2 (U1) | Compact, dual-channel, precision, PGTIA | Analog Devices, Inc., ADA4352-2ACPZ |
| 3 | C1, C2, C3 | 10 μ F capacitor, 1206 | Murata, GCM31CR71C106KA64K |
| 2 | C20, C22 | 4.7 μ F capacitor, 1206 | Murata, GRM31CR71H475KA12L |
| 3 | C4, C5, C6 | 0.1 μ F capacitor, 0603 | TDK, C1608X8R1E104K080AA |
| 4 | C8, C9, C19, C21 | 1 pF capacitor, 0603 | AVX, 06031A1R0BAT2A |
| 10 | J1, J2, J3, J4, J5, J6, J7, J8, J9, J10 | SMA female, edge-mounted sockets | Cinch, 142-0701-851 |
| 7 | P1, P2, P4, P5, P6, P7, P8 | 2-pin headers, 2.54 mm through hole, vertical | Amphenol FCI, 69157-102HLF |
| 1 | P3 | 3-pin header, 2.54 mm through hole, vertical | Samtec Inc., TSW-103-23-F-S |
| 2 | R19, R20 | 10 k Ω resistor, 0402 | Panasonic, ERJ-2RK1002X |
| 8 | R2, R4, R8, R12, R14, R16, R28, R31 | 0 Ω resistor, 0603 | Panasonic, ERJ-3GEY0R00V |
| 6 | R6, R10, R21, R23, R25, R26 | 1 k Ω resistor, 0603 | Panasonic, ERJ-3EKF1001V |
| 6 | TP1, TP2, TP3, TP4, TP8, TP9 | Black test points, through hole, 1.02 mm diameter | Vero Technologies, 20-2137 |
| 2 | TP5, TP7 | Red test points, through hole, 1.02 mm diameter | Vero Technologies, 20-313137 |
| 1 | TP6 | Blue test point, through hole, 1.02 mm diameter | Components Corporation, TP104-01-06 |
| 1 | Not applicable | ADA4352-2 evaluation board | EVAL-ADA4352-2EBZ |
| 4 | Not applicable | Standoff | Keystone, 1902C |
| 4 | Not applicable | Screw | B&F Fastener Supply, NY PMS 440 0025 PH |

Revision History

| Revision Number | Revision Date | Description | Pages Changed |
|------------------------|----------------------|--------------------|----------------------|
| 0 | 09/24 | Initial release | — |

Notes

ALL INFORMATION CONTAINED HEREIN IS PROVIDED “AS IS” WITHOUT REPRESENTATION OR WARRANTY. NO RESPONSIBILITY IS ASSUMED BY ANALOG DEVICES FOR ITS USE, NOR FOR ANY INFRINGEMENTS OF PATENTS OR OTHER RIGHTS OF THIRD PARTIES THAT MAY RESULT FROM ITS USE. SPECIFICATIONS ARE SUBJECT TO CHANGE WITHOUT NOTICE. NO LICENSE, EITHER EXPRESSED OR IMPLIED, IS GRANTED UNDER ANY ADI PATENT RIGHT, COPYRIGHT, MASK WORK RIGHT, OR ANY OTHER ADI INTELLECTUAL PROPERTY RIGHT RELATING TO ANY COMBINATION, MACHINE, OR PROCESS, IN WHICH ADI PRODUCTS OR SERVICES ARE USED. TRADEMARKS AND REGISTERED TRADEMARKS ARE THE PROPERTY OF THEIR RESPECTIVE OWNERS. ALL ANALOG DEVICES PRODUCTS CONTAINED HEREIN ARE SUBJECT TO RELEASE AND AVAILABILITY.

Mouser Electronics

Authorized Distributor

Click to View Pricing, Inventory, Delivery & Lifecycle Information:

[Analog Devices Inc.:](#)

[EVAL-ADA4352-2EBZ](#)