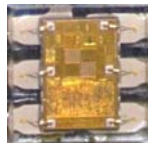

## Features

- **Ambient Light Sensing and Proximity Detection in Single Device**
- **Ambient Light Sensing (ALS)**
  - Approximates Human Eye Response
  - Programmable Analog Gain
  - Programmable Integration Time
  - Programmable Interrupt Function with Upper and Lower Threshold
  - Resolution Up to 16 Bits
  - Very High Sensitivity — Operates Well Behind Darkened Glass
  - Up to 1,000,000:1 Dynamic Range
- **Proximity Detection**
  - Programmable Number of IR Pulses
  - Programmable Current Sink for the IR LED — No Limiting Resistor Needed
  - Programmable Interrupt Function with Upper and Lower Threshold
  - Covers a 2000:1 Dynamic Range
- **Programmable Wait Timer**
  - Programmable from 2.72 ms to > 8 Seconds
  - Wait State — 65  $\mu$ A Typical Current

## PACKAGE FN DUAL FLAT NO-LEAD (TOP VIEW)

V <sub>DD</sub> 1		6 SDA
SCL 2		5 INT
GND 3		4 LDR

- **I<sup>2</sup>C Interface Compatible**
  - Up to 400 kHz (I<sup>2</sup>C Fast Mode)
  - Dedicated Interrupt Pin
- **Small 2 mm × 2 mm ODFN Package**
- **Sleep Mode — 2.5  $\mu$ A Typical Current**

## Applications

- **Cell Phone Backlight Dimming**
- **Cell Phone Touch Screen Disable**
- **Notebook/Monitor Security**
- **Automatic Speakerphone Enable**
- **Automatic Menu Popup**

## Description

The TSL2771 family of devices provides both ambient light sensing (ALS) and proximity detection (when coupled with an external IR LED). The ALS approximates human eye response to light intensity under a variety of lighting conditions and through a variety of attenuation materials. The proximity detection feature allows a large dynamic range of operation for use in short distance detection behind dark glass such as in a cell phone or for longer distance measurements for applications such as presence detection for monitors or laptops. The programmable proximity detection enables continuous measurements across the entire range. In addition, an internal state machine provides the ability to put the device into a low power mode in between ALS and proximity measurements providing very low average power consumption.

While useful for general purpose light sensing, the TSL2771 is particularly useful for display management with the purpose of extending battery life and providing optimum viewing in diverse lighting conditions. Display panel and keyboard backlighting can account for up to 30 to 40 percent of total platform power. The ALS features are ideal for use in notebook PCs, LCD monitors, flat-panel televisions, and cell phones.

The proximity function is targeted specifically towards cell phone, LCD monitor, laptop, and flat-panel television applications. In cell phones, the proximity detection can detect when the user positions the phone close to their ear. The device is fast enough to provide proximity information at a high repetition rate needed when answering a phone call. It can also detect both close and far distances so the application can implement more complex algorithms to provide a more robust interface. In laptop or monitor applications, the product is sensitive enough to determine whether a user is in front of the laptop using the keyboard or away from the desk. This provides both improved “green” power saving capability and the added security to lock the computer when the user is not present.

# TSL2771 LIGHT-TO-DIGITAL CONVERTER with PROXIMITY SENSING

TAOS100A – FEBRUARY 2010

## Functional Block Diagram

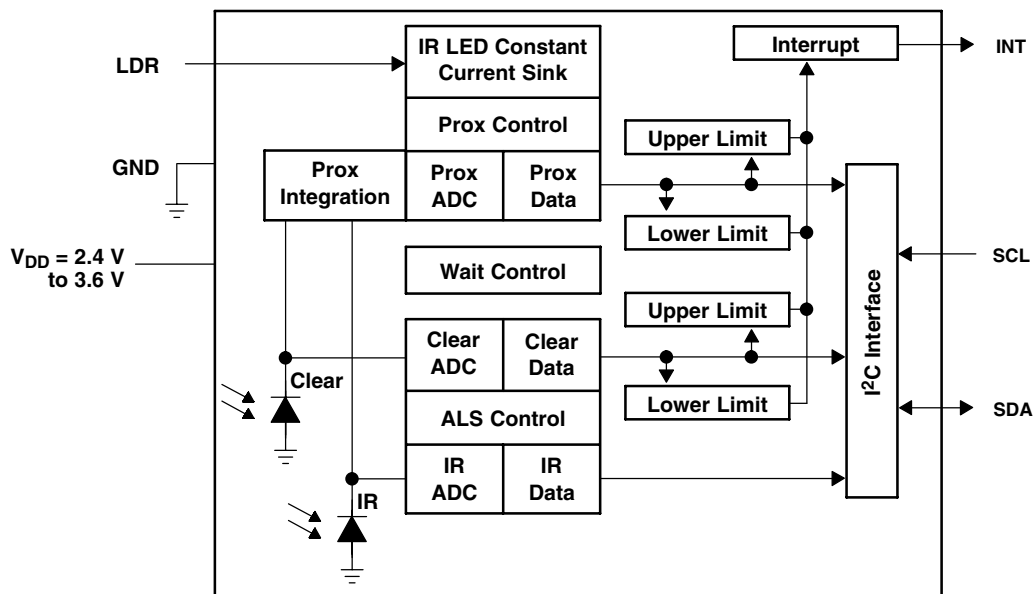

## Detailed Description

The TSL2771 light-to-digital device provides on-chip clear and IR diodes, integrating amplifiers, ADCs, accumulators, clocks, buffers, comparators, a state machine and an I<sup>2</sup>C interface. Each device combines one clear photodiode (visible plus infrared) and one infrared-responding (IR) photodiode. Two integrating ADCs simultaneously convert the amplified photodiode currents into a digital value providing up to 16 bits of resolution. Upon completion of the conversion cycle, the conversion result is transferred to the clear and IR data registers. This digital output can be read by a microprocessor through which the illuminance (ambient light level) in Lux is derived using an empirical formula to approximate the human eye response.

Communication to the device is accomplished through a fast (up to 400 kHz), two-wire I<sup>2</sup>C serial bus for easy connection to a microcontroller or embedded controller. The digital output of the TSL2771 device is inherently more immune to noise when compared to an analog interface.

The TSL2771 provides a separate pin for level-style interrupts. When interrupts are enabled and a pre-set value is exceeded, the interrupt pin is asserted and remains asserted until cleared by the controlling firmware. The interrupt feature simplifies and improves system efficiency by eliminating the need to poll a sensor for a light intensity or proximity value. An interrupt is generated when the value of an ALS or proximity conversion exceeds either an upper or lower threshold. In addition, a programmable interrupt persistence feature allows the user to determine how many consecutive exceeded thresholds are necessary to trigger an interrupt. Interrupt thresholds and persistence settings are configured independently for both ALS and proximity.

Proximity detection requires only a single external IR LED. An internal LED driver can be configured to provide a constant current sink of 12.5 mA, 25 mA, 50 mA, or 100 mA of current. No external current limiting resistor is required. The number of proximity LED pulses can be programmed from 1 to 255 pulses. Each pulse has a 16- $\mu$ s period. This LED current coupled with the programmable number of pulses provides a 2000:1 contiguous dynamic range.

### Terminal Functions

TERMINAL FN PKG NO.	NAME	TYPE	DESCRIPTION
1	V <sub>DD</sub>		Supply voltage.
2	SCL	I	I <sup>2</sup> C serial clock input terminal — clock signal for I <sup>2</sup> C serial data.
3	GND		Power supply ground. All voltages are referenced to GND.
4	LDR	O	LED driver for proximity emitter — up to 100 mA, open drain.
5	INT	O	Interrupt — open drain.
6	SDA	I/O	I <sup>2</sup> C serial data I/O terminal — serial data I/O for I <sup>2</sup> C .

### Available Options

DEVICE	PACKAGE – LEADS	INTERFACE DESCRIPTION	ORDERING NUMBER
TSL27711	FN-6	I <sup>2</sup> C Vbus = V <sub>DD</sub> Interface	TSL27711FN
TSL27713	FN-6	I <sup>2</sup> C Vbus = 1.8 V Interface	TSL27713FN

### Absolute Maximum Ratings over operating free-air temperature range (unless otherwise noted)<sup>†</sup>

Supply voltage, V <sub>DD</sub> (see Note 1)	3.8 V
Digital output voltage range, V <sub>O</sub>	–0.5 V to 3.8 V
Digital output current, I <sub>O</sub>	–1 mA to 20 mA
Storage temperature range, T <sub>stg</sub>	–40°C to 85°C
ESD tolerance, human body model	2000 V

<sup>†</sup> Stresses beyond those listed under “absolute maximum ratings” may cause permanent damage to the device. These are stress ratings only, and functional operation of the device at these or any other conditions beyond those indicated under “recommended operating conditions” is not implied. Exposure to absolute-maximum-rated conditions for extended periods may affect device reliability.

NOTE 1: All voltages are with respect to GND.

### Recommended Operating Conditions

	MIN	NOM	MAX	UNIT
Supply voltage, V <sub>DD</sub>	2.4	3	3.6	V
Operating free-air temperature, T <sub>A</sub>	–30		70	°C

# TSL2771 LIGHT-TO-DIGITAL CONVERTER with PROXIMITY SENSING

TAOS100A – FEBRUARY 2010

## Operating Characteristics, $V_{DD} = 3\text{ V}$ , $T_A = 25^\circ\text{C}$ (unless otherwise noted)

PARAMETER		TEST CONDITIONS	MIN	TYP	MAX	UNIT
$I_{DD}$	Supply current	Active — $ATIME = 100\text{ ms}$		175	250	$\mu\text{A}$
		Wait mode		65		
		Sleep mode		2.5	4	
$V_{OL}$	INT, SDA output low voltage	3 mA sink current	0		0.4	V
		6 mA sink current	0		0.6	
$I_{LEAK}$	Leakage current, SDA, SCL, INT pins		-5		5	$\mu\text{A}$
$I_{LEAK}$	Leakage current, LDR pin		$\pm 10$			$\mu\text{A}$
$V_{IH}$	SCL, SDA input high voltage	TSL27711	$0.7 V_{DD}$			V
		TSL27713	1.25			
$V_{IL}$	SCL, SDA input low voltage	TSL27711	$0.3 V_{DD}$			V
		TSL27713	0.54			

## ALS Characteristics, $V_{DD} = 3\text{ V}$ , $T_A = 25^\circ\text{C}$ , Gain = 16, AEN = 1 (unless otherwise noted) (Notes 1, 2, 3)

PARAMETER		TEST CONDITIONS	CHANNEL	MIN	TYP	MAX	UNIT
Dark ALS ADC count value		$E_e = 0$ , $AGAIN = 120\times$ , $ATIME = 0x\text{DB}$ (100 ms)	Clear	0	1	5	counts
			IR	0	1	5	
ALS ADC integration time step size		$ATIME = 0x\text{FF}$		2.58	2.72	2.9	ms
ALS ADC Number of integration steps				1		256	steps
Full scale ADC counts per step				1024			steps
Full scale ADC count value		$ATIME = 0x\text{C0}$		65535			steps
ALS ADC count value		$\lambda_p = 625\text{ nm}$ , $E_e = 171.6\ \mu\text{W}/\text{cm}^2$ , $ATIME = 0x\text{F6}$ (27 ms), $GAIN = 16\times$ See note 2.	Clear	4000	5000	6000	counts
			IR	790			
		$\lambda_p = 850\text{ nm}$ , $E_e = 219.7\ \mu\text{W}/\text{cm}^2$ , $ATIME = 0x\text{F6}$ (27 ms), $GAIN = 16\times$ See note 3.	Clear	4000	5000	6000	
			IR	2800			
ALS ADC count value ratio: Clear/IR		$\lambda_p = 625\text{ nm}$ , $ATIME = 0x\text{F6}$ (27 ms) See note 2.		10.8	15.8	20.8	%
		$\lambda_p = 850\text{ nm}$ , $ATIME = 0x\text{F6}$ (27 ms) See note 3.		41	56	68	
$R_e$	Irradiance responsivity	$\lambda_p = 625\text{ nm}$ , $ATIME = 0x\text{F6}$ (27 ms) See note 2.	Clear	29.1			counts/ ( $\mu\text{W}/\text{cm}^2$ )
			IR	4.6			
		$\lambda_p = 850\text{ nm}$ , $ATIME = 0x\text{F6}$ (27 ms) See note 3.	Clear	22.8			
			IR	12.7			
Gain scaling, relative to 1 $\times$ gain setting		8 $\times$		-10		10	%
		16 $\times$		-10		10	
		120 $\times$		-10		10	

- NOTES: 1. Optical measurements are made using small-angle incident radiation from light-emitting diode optical sources. Visible 625 nm LEDs and infrared 850 nm LEDs are used for final product testing for compatibility with high-volume production.
2. The 625 nm irradiance  $E_e$  is supplied by an AlInGaP light-emitting diode with the following typical characteristics: peak wavelength  $\lambda_p = 625\text{ nm}$  and spectral halfwidth  $\Delta\lambda_{1/2} = 20\text{ nm}$ .
3. The 850 nm irradiance  $E_e$  is supplied by a GaAs light-emitting diode with the following typical characteristics: peak wavelength  $\lambda_p = 850\text{ nm}$  and spectral halfwidth  $\Delta\lambda_{1/2} = 42\text{ nm}$ .

# TSL2771 LIGHT-TO-DIGITAL CONVERTER with PROXIMITY SENSING

TAOS100A – FEBRUARY 2010

## Proximity Characteristics, $V_{DD} = 3\text{ V}$ , $T_A = 25^\circ\text{C}$ , Gain = 16, PEN = 1 (unless otherwise noted)

PARAMETER	TEST CONDITIONS	CONDITION	MIN	TYP	MAX	UNIT
$I_{DD}$ Supply current — LDR pulse on				3		mA
ADC conversion time step size	PTIME = 0xFF		2.58	2.72	2.9	ms
ALS ADC number of integration steps			1		256	steps
Full scale ADC counts per step				1024		steps
Proximity IR LED pulse count			0		255	pulses
Proximity pulse period	Two or more pulses			16		$\mu\text{s}$
Proximity pulse — LED on time				7.33		$\mu\text{s}$
Proximity LED Drive	$I_{SINK}$ sink current @ 600 mV, LDR pin	PDRIVE=0	75	100	125	mA
		PDRIVE=1		50		
		PDRIVE=2		25		
		PDRIVE=3		12.5		
Proximity distance §				18		inches

§ Proximity Distance is dependent upon emitter properties the reflective properties of the proximity reflecting surface. The nominal value shown uses an IR emitter with a peak wavelength of 850nm and a 20° half angle. The proximity reflecting surface used is a 16" x 20" Kodak 90% grey card. 60 mw/SR, 100 mA, 64 pulses, open view (no glass). **Note:** Greater distances are achievable with appropriate system considerations.

## Wait Characteristics, $V_{DD} = 3\text{ V}$ , $T_A = 25^\circ\text{C}$ , Gain = 16, WEN = 1 (unless otherwise noted)

PARAMETER	TEST CONDITIONS	CHANNEL	MIN	TYP	MAX	UNIT
Wait step size	WTIME = 0xFF		2.58	2.72	2.9	ms
Wait number of integration steps			1		256	steps

## AC Electrical Characteristics, $V_{DD} = 3\text{ V}$ , $T_A = 25^\circ\text{C}$ (unless otherwise noted)

PARAMETER†	TEST CONDITIONS	MIN	TYP	MAX	UNIT
$f_{(SCL)}$ Clock frequency (I <sup>2</sup> C only)		0		400	kHz
$t_{(BUF)}$ Bus free time between start and stop condition		1.3			$\mu\text{s}$
$t_{(HDSTA)}$ Hold time after (repeated) start condition. After this period, the first clock is generated.		0.6			$\mu\text{s}$
$t_{(SUSTA)}$ Repeated start condition setup time		0.6			$\mu\text{s}$
$t_{(SUSTO)}$ Stop condition setup time		0.6			$\mu\text{s}$
$t_{(HDDAT)}$ Data hold time		0			$\mu\text{s}$
$t_{(SUDAT)}$ Data setup time		100			ns
$t_{(LOW)}$ SCL clock low period		1.3			$\mu\text{s}$
$t_{(HIGH)}$ SCL clock high period		0.6			$\mu\text{s}$
$t_F$ Clock/data fall time				300	ns
$t_R$ Clock/data rise time				300	ns
$C_i$ Input pin capacitance				10	pF

† Specified by design and characterization; not production tested.

**TSL2771**  
**LIGHT-TO-DIGITAL CONVERTER**  
**with PROXIMITY SENSING**

TAOS100A – FEBRUARY 2010

**PARAMETER MEASUREMENT INFORMATION**

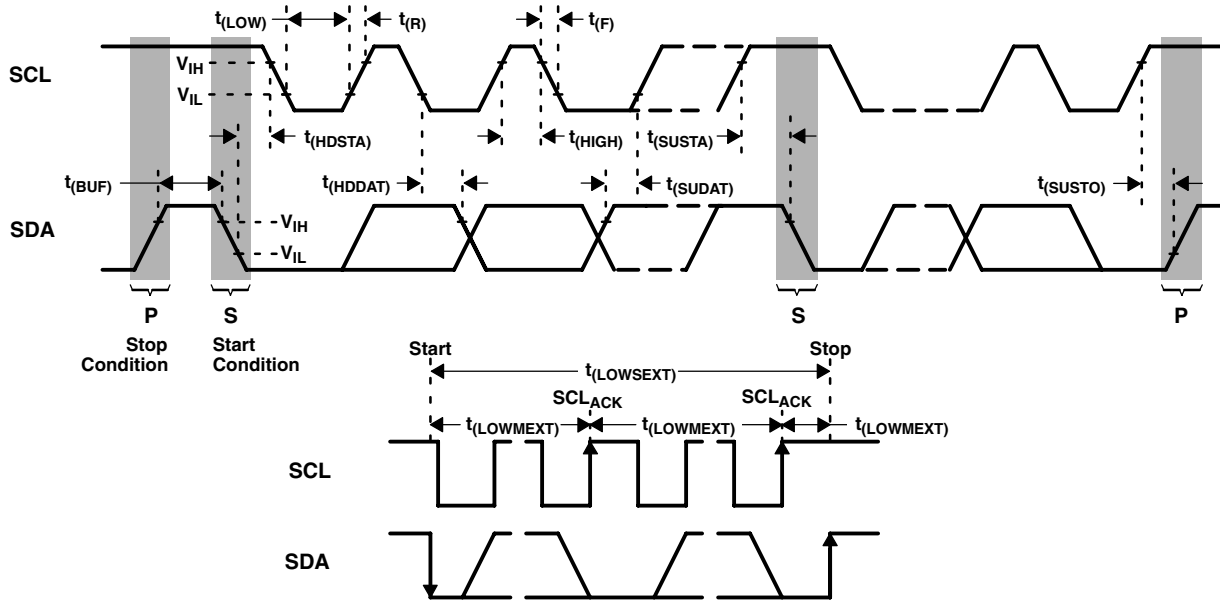

**Figure 1. Timing Diagrams**

**TYPICAL CHARACTERISTICS**

**SPECTRAL RESPONSIVITY**

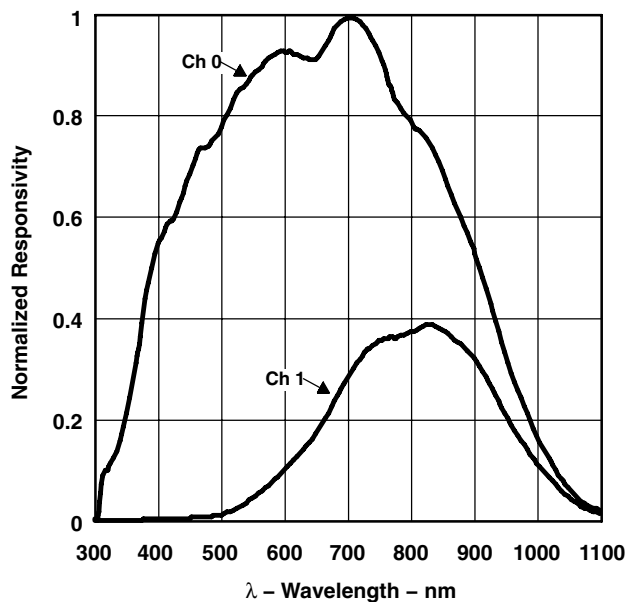

**Figure 2**

**LDR OUTPUT COMPLIANCE**

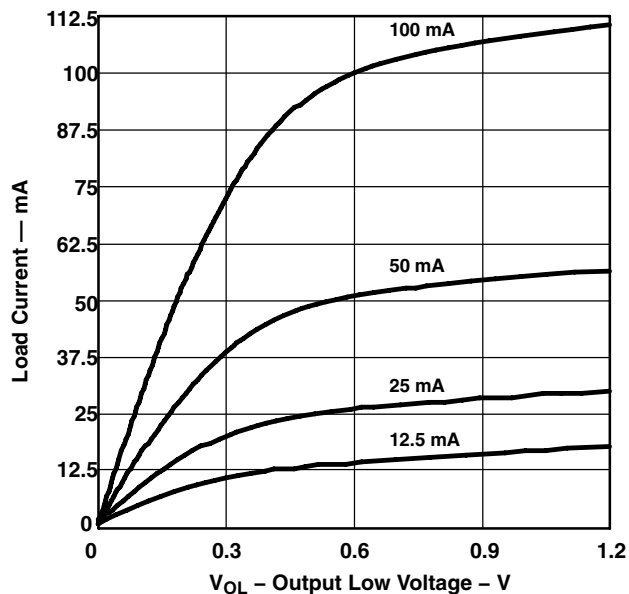

**Figure 3**

**NORMALIZED  $I_{DD}$   
 vs.  
 $V_{DD}$  and TEMPERATURE**

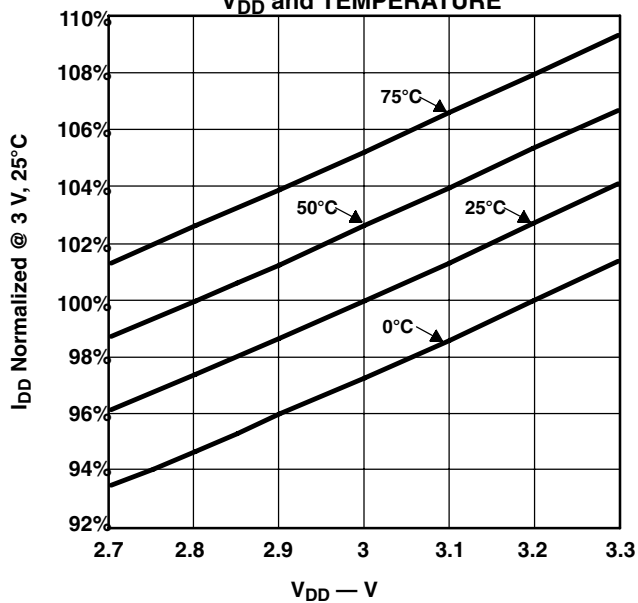

**Figure 4**

**NORMALIZED RESPONSIVITY  
 vs.  
 ANGULAR DISPLACEMENT**

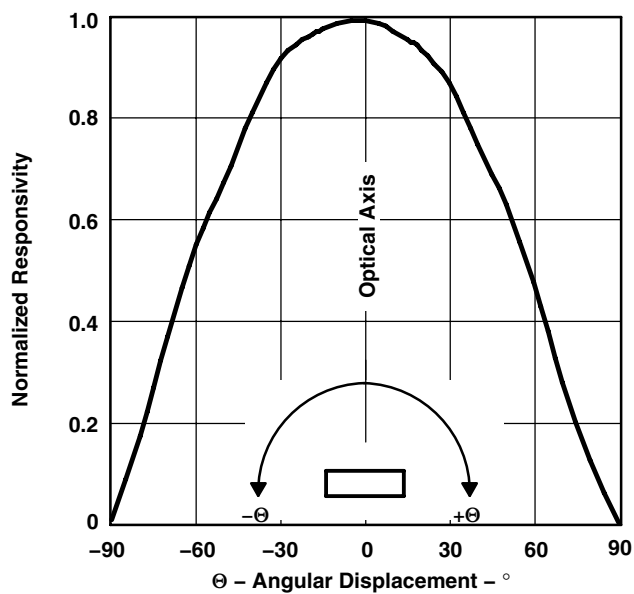
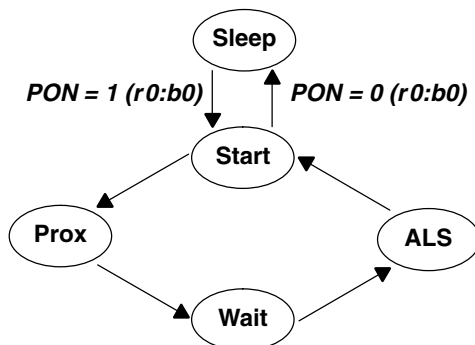

**Figure 5**

**PRINCIPLES OF OPERATION**

**System State Machine**

The TSL2771 provides control of ALS, proximity detection, and power management functionality through an internal state machine (Figure 6). After a power-on-reset, the device is in the sleep mode. As soon as the PON bit is set, the device will move to the start state. It will then continue through the Prox, Wait, and ALS states. If these states are enabled, the device will execute each function. If the PON bit is set to 0, the state machine will continue until all conversions are completed and then go into a low power sleep mode.



**Figure 6. Simplified State Diagram**

**NOTE:** In this document, the nomenclature uses the bit field name in italics followed by the register number and bit number to allow the user to easily identify the register and bit that controls the function. For example, the power on (PON) is in register 0, bit 0. This is represented as *PON (r0:b0)*.

**Clear and IR Diodes**

Conventional silicon detectors respond strongly to infrared light, which the human eye does not see. This can lead to significant error when the infrared content of the ambient light is high (such as with incandescent lighting) due to the difference between the silicon detector response and the brightness perceived by the human eye.

This problem is overcome in the TSL2771 through the use of two photodiodes. One of the photodiodes, referred to as the clear channel, is sensitive to both visible and infrared light while the second photodiode is sensitive primarily to infrared light. Two integrating ADCs convert the photodiode currents to digital outputs. The IRDATA digital value is used to compensate for the effect of the infrared component of light on the CDATA (clear) digital value. The ADC digital outputs from the two channels are used in a formula to obtain a value that approximates the human eye response in units of lux.



## ALS Operation

The ALS engine contains ALS gain control (AGAIN) and two integrating analog-to-digital converters (ADC) for the clear and IR photodiodes (Figure 7). The ALS integration time (ATIME) impacts both the resolution and the sensitivity of the ALS reading. Integration of both channels occurs simultaneously and upon completion of the conversion cycle, the results are transferred to the clear and IR data registers (CDATAx and IR DATAx). This data is also referred to as channel *count*. The transfers are double-buffered to ensure that invalid data is not read during the transfer. After the transfer, the device automatically moves to the next state in accordance with the configured state machine.

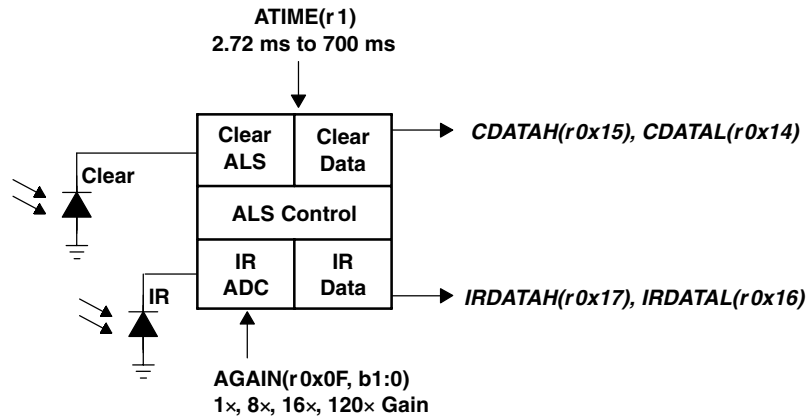

**Figure 7. ALS Operation**

The ALS gain can be set to amplify the clear channel and IR channel by 1, 8, 16, or 120X. The register bits CONTROL (r0x0F, b1:0) are used to set the gain.

Integration time can be set from 2.7ms to 700ms. The registers for programming the integration and wait times are a 2's compliment values. The actual time can be calculated as follows:

$$ATIME = 256 - \text{Integration Time} / 2.72 \text{ ms}$$

Inversely, the time can be calculated from the register value as follows:

$$\text{Integration Time} = 2.72 \text{ ms} \times (256 - ATIME)$$

For example, if a 100-ms integration time is needed, the device needs to be programmed to:

$$256 - (100 / 2.72) = 256 - 37 = 219 = 0xDB$$

Conversely, the programmed value of 0xC0 would correspond to:

$$(256 - 0xC0) \times 2.72 = 64 \times 2.72 = 172 \text{ ms.}$$

# TSL2771 LIGHT-TO-DIGITAL CONVERTER with PROXIMITY SENSING

TAOS100A – FEBRUARY 2010

## Calculating Lux

The lux calculation is a function of several factors including the clear channel count (CDATA), IR channel count (IRDATA), ALS gain (AGAIN), and ALS integration time (ATIME). The Clear and IR channel information is used to calculate an *IR Factor* (IRF) and IR adjusted count (IAC), which indicates the attenuation to the clear channel to account for the IR content in the signal. The IR Factor is calculated based on empirical device measurements under different lighting conditions. Count per lux (CPL) is a function of the AGAIN, ATIME, light attenuation, and a device factor (DF).

Lux is also dependent upon light attenuation, referred to as *glass attenuation* (GA). This is used to scale the lux value to account for some interference such as an aperture, neutral density filter, or a light pipe. If light is attenuated equally across the spectrum (300 nm to 1100 nm), then a linear GA can be used to compensate for the light loss of the system. If the sensor is exposed to light without an aperture in an open-air system, then GA is unity. If the GA is nonlinear, then the IR Factor and LPC will need to be derived under the new conditions.

The lux value can be calculated from the following equation:

$$\text{lux} = \text{IR Adjusted Count (IAC)} \times \text{Counts per lux (CPL)}$$

Where:

$$\text{IAC} = \text{IRF} \times \text{CDATA}$$

$$\text{CPL} = \text{Integration Time} \times \text{Gain} / \text{GA} \times \text{DF}$$

For the TSL2771x FN package in open air to the light source, this factor is 52.

## RAW Channel Data

Lux is calculated as a function of the clear count (CDATA) and IR count (IRDATA). Because all registers are byte-oriented, 16-bit DATA must be created from two register reads:

$$\text{CDATA} = 256 \times \text{CDATAH (r0x15)} + \text{CDATA (r0x14)}$$

Likewise:

$$\text{IRDATA} = 256 \times \text{IRDATAH (r0x17)} + \text{IRDATA (r0x16)}$$

## Saturation

The device can saturate if the light is brighter than can be accumulated with the light-to-frequency conversion. The full scale value for saturation will depend upon the integration time programmed into the device. In saturation, the device accumulates 1024 counts for each 2.72 ms of integration time programmed. For each ATIME programmed, the maximum count (saturation level) is the lesser of  $(1024 \times (256 - \text{ATIME}))$  or 65,535.

There is also a second condition that impacts saturation. If there is ripple in the received signal, such as under fluorescent lights, then the signal will go in and out of saturation and the value read from clear or IR channel will be less than the maximum but still have some effects of being saturated. Because of this, it is necessary to lower gain if channel values are above 70% of the saturated calculation. This is especially true in high gain mode with AC-modulated light sources that produce flicker. Under this condition, a channel reading may be slightly below the saturated calculation but in reality be saturated during the peaks, resulting in a value less than the actual light level.

If the ALS integration time is greater than 172  $\mu\text{s}$ , the saturation level is 50,000, otherwise it is calculated as:

$$\text{SATURATION} = 0.75 \times (1024 \times (256 - \text{ATIME}) - 1)$$

## IR Factor and IAC

The IR factor (IRF) is derived from the clear channel (CDATA), which is sensitive to both visible and infrared light, and the IR channel (IRDATA), which is sensitive primarily to infrared light. The IR Factor is calculated based on the ratio of the two photodiodes, which provides an optimized equation.

$$\text{RATIO} = \text{IRDATA} / \text{CDATA}$$

Because the two photodiodes have different spectral responses, the ratio of the channels will vary depending on a particular light source's spectral power distribution (SPD). Light sources such as an incandescent bulb or sunlight have high amounts of infrared energy, while fluorescent bulbs have virtually no infrared energy. Fluorescent lights have an IR Factor of approximately 80%; while incandescent light sources, with large amounts IR, have IR Factors between 10% and 20%.

For RATIO = 0% to 30%	IRF = (1.000 – 1.846 × RATIO)
For RATIO = 30% to 38%	IRF = (1.268 – 2.740 × RATIO)
For RATIO = 38% to 45%	IRF = (0.749 – 1.374 × RATIO)
For RATIO = 45% to 54%	IRF = (0.477 – 0.769 × RATIO)
For RATIO > 54%	IRF = 0

IRF is used in understanding the light attenuation under different circumstances. However, it is seldom calculated in the actual implementation. IAC is typically used such that the RATIO not needed in this calculation.

For RATIO = 0% to 30%	IAC = (1.000 × CDATA – 1.846 × IRDATA)
For RATIO = 30% to 38%	IAC = (1.268 × CDATA – 2.740 × IRDATA)
For RATIO = 38% to 45%	IAC = (0.749 × CDATA – 1.374 × IRDATA)
For RATIO = 45% to 54%	IAC = (0.477 × CDATA – 0.769 × IRDATA)
For RATIO > 54%	IAC = 0

## Sample Lux Calculation

Assume:

GA = 1, Gain = 16, Integration Time = 200 ms  
 Clear Data = 19476, IR Data = 1438 decimal

First, calculate IAC

$$\text{Ratio} = \text{IRDATA} / \text{CDATA} = 1438 / 19476 = 7.4\%$$

For a ratio of 7.4%, use the first equation:

$$\begin{aligned} \text{IAC} &= (1.000 \times \text{CDATA} - 1.846 \times \text{IRDATA}) \\ \text{IAC} &= (1.000 \times 19476 - 1.846 \times 1438) \\ \text{IAC} &= 16821 \end{aligned}$$

Next, calculate CPL:

$$\begin{aligned} \text{CPL} &= (\text{Integration Time} \times \text{Gain}) / \text{GA} \times \text{DF} \\ \text{CPL} &= 200 \times 16 / (1 \times 52) \\ \text{CPL} &= 61.5 \end{aligned}$$

Finally, calculate lux:

$$\begin{aligned} \text{lux} &= 16821 / 61.5 \\ \text{lux} &= 273 \end{aligned}$$

Various techniques can be used to eliminate floating point calculations such as multiplying coefficients by 1000 or 1024. Care must be taken to keep the math in the integer size allocated and to keep the appropriate amount of precision to avoid round-off errors.



# TSL2771 LIGHT-TO-DIGITAL CONVERTER with PROXIMITY SENSING

TAOS100A – FEBRUARY 2010

## Fluorescent Ripple Rejection

There are many factors that will impact the decision on which value to use for integration time and gain. One of the first factors is 50/60-Hz ripple rejection for fluorescent lighting. The programmed value needs to be multiples of 10 / 8.3 ms, or the half cycle time. Both frequencies can be rejected with a programmed value of 50 ms (ATIME=0xED). With this value, the resolution will be 1.3 lux per count. If higher resolution is needed, a longer integration time may be needed. In this case, the integration time should be programmed in multiples of 50.

## Recommended ALS Operations

With the programming versatility of the integration time and gain, it can be difficult to understand when to use the different modes. Figure 8 shows a plot of the IRF equations. Figure 9 shows a log-log plot of the lux vs. integration time and gain with a spectral factor of unity and no IR present.

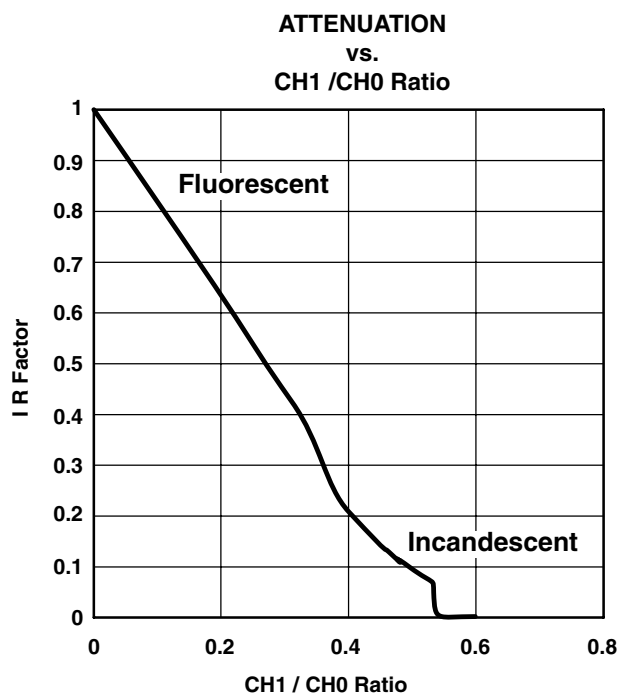

Figure 8

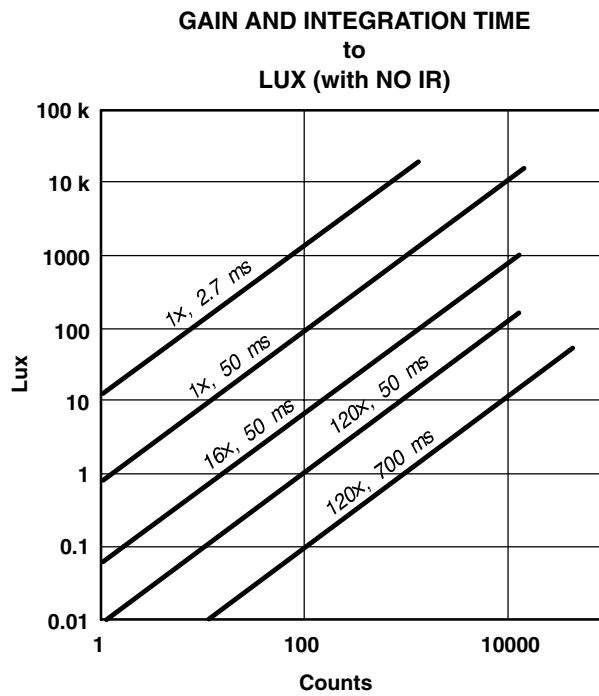

Figure 9

The maximum illuminance that can be measured is approximately 19 k-lux with no IR present. The intercept with a count of 1 shows the resolution of each setting. The lux values in the table increase as the SF increases (spectral attenuation increases). For example, if a 10% transmissive glass is used, the lux values would all be multiplied by 10. The lux values in the table decrease as the IR Factor decreases. For example, with a 10% IR Factor, which corresponds to a strong incandescent light, the Lux value would need to be divided by 10.

The light level is the next determining factor for configuring device settings. Under bright conditions, the count will be fairly high. If a low light measurement is needed, a higher gain and/or longer integration time will be needed. As a general rule, it is recommended to have a clear channel count of at least 10 to accurately apply the lux equation.

The digital accumulation is limited to 16 bits, which occurs at an integration time of 173 ms. This is the maximum recommended programmed integration time before increasing the gain. (150 ms is the maximum to reduce the fluorescent ripple.)

## Proximity Detection

Proximity sensing uses an external light source (generally an infrared emitter) to emit light, which is then viewed by the integrated light detector to measure the amount of reflected light when an object is in the light path (Figure 10). The amount of light detected from a reflected surface can then be used to determine an object's proximity to the sensor.

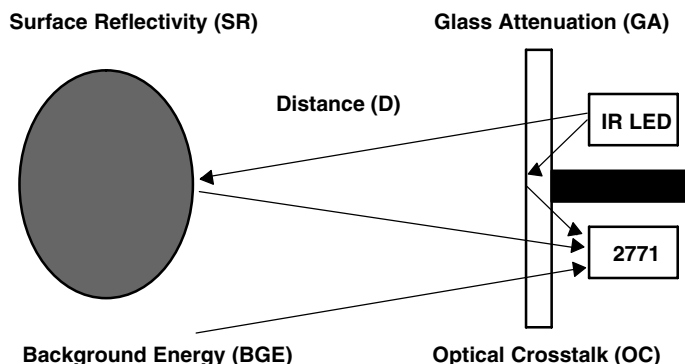

**Figure 10. Proximity Detection**

The TSL2771 has controls for the number of IR pulses (PPCOUNT), the integration time (PTIME), the LED drive current (PDRIVE), and the photodiode configuration (PDIODE) (Figure 11). The photodiode configuration can be set to infrared diode (recommended), clear diode, or a combination of both diodes. At the end of the integration cycle, the results are latched into the proximity data (PDATA) register.

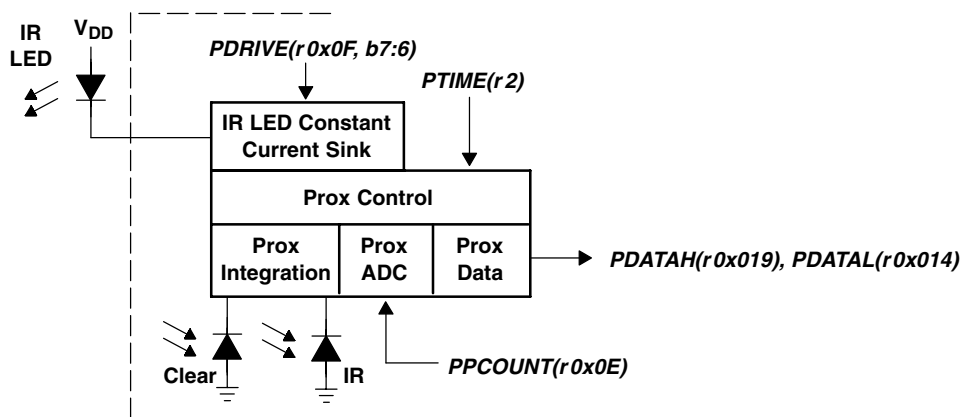

**Figure 11. Proximity Detection Operation**

The LED drive current is controlled by a regulated current sink on the LDR pin. This feature eliminates the need to use a current limiting resistor to control LED current. The LED drive current can be configured for 12.5 mA, 25 mA, 50 mA, or 100 mA. For higher LED drive requirements, an external P type transistor can be used to control the LED current.

The number of LED pulses can be programmed to any value between 1 and 255 pulses as needed. Increasing the number of LED pulses at a given current will increase the sensor sensitivity. Sensitivity grows by the square root of the number of pulses. Each pulse has a 16- $\mu$ s period.

**TSL2771**  
**LIGHT-TO-DIGITAL CONVERTER**  
**with PROXIMITY SENSING**

TAOS100A – FEBRUARY 2010

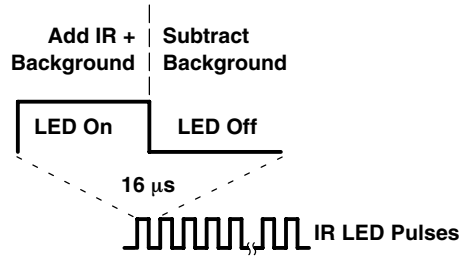

**Figure 12. Proximity IR LED Waveform**

The proximity integration time (PTIME) is the period of time that the internal ADC converts the analog signal to a digital count. It is recommend that this be set to a minimum of PTIME = 0xFF or 2.72 ms.

The combination of LED power and number of pulses can be used to control the distance at which the sensor can detect proximity. Figure 13 shows an example of the distances covered with settings such that each curve covers 2x the distance. Counts up to 64 pulses provide a 16x range.

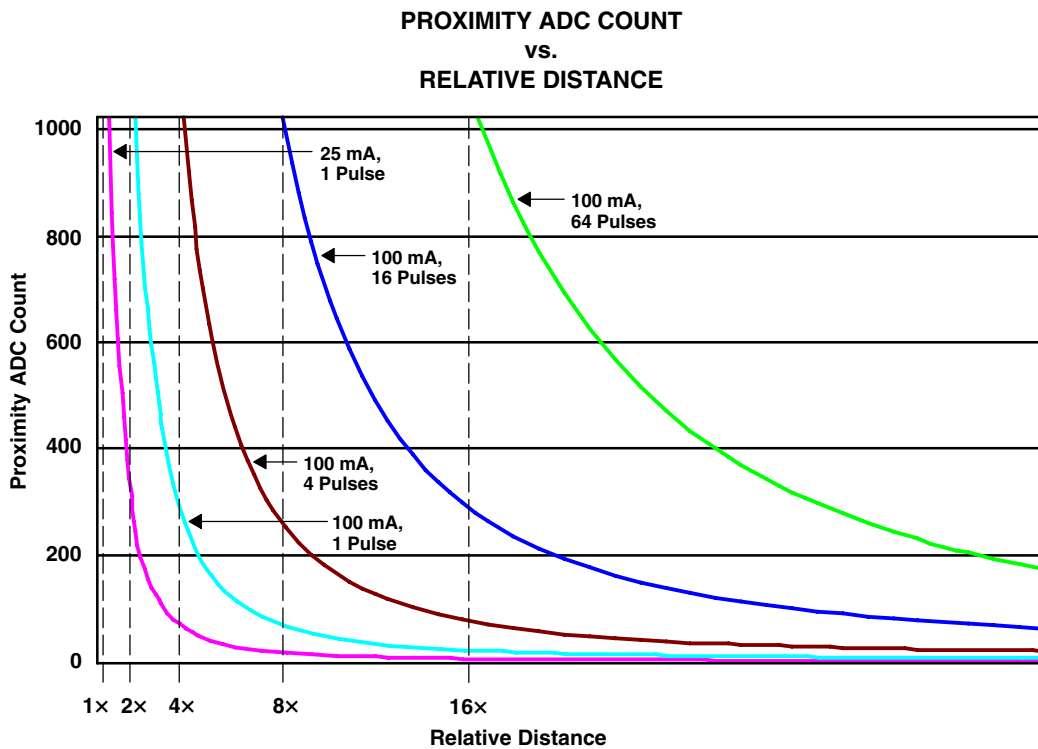

**Figure 13**

## Interrupts

The interrupt feature of the TSL2771 simplifies and improves system efficiency by eliminating the need to poll the sensor for a light intensity or proximity value. The interrupt mode is determined by the PIEN or AIEN field in the ENABLE register.

The TSL2771 implements four 16-bit-wide interrupt threshold registers that allow the user to define thresholds above and below a desired light level. For ALS, an interrupt can be generated when the ALS clear data (CDATA) exceeds the upper threshold value (AIHTx) or falls below the lower threshold (AILTx). For proximity, an interrupt can be generated when the proximity data (PDATA) exceeds the upper threshold value (PIHTx) or falls below the lower threshold (PILTx).

To further control when an interrupt occurs, the TSL2771 provides an interrupt persistence feature. This feature allows the user to specify a number of conversion cycles for which an event exceeding the ALS interrupt threshold must persist (APERS) or the proximity interrupt threshold must persist (PPERS) before actually generating an interrupt. Refer to the register descriptions for details on the length of the persistence.

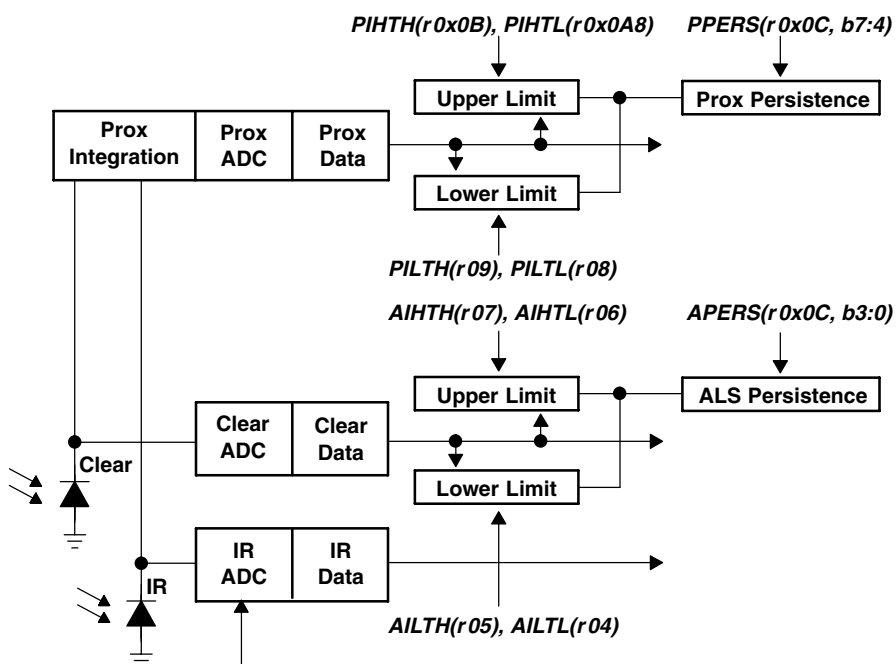

**Figure 14. Programmable Interrupt**

# TSL2771 LIGHT-TO-DIGITAL CONVERTER with PROXIMITY SENSING

TAOS100A – FEBRUARY 2010

## State Diagram

Figure 15 shows a more detailed flow for the state machine. The device starts in the sleep mode. The PON bit is written to enable the device. A 2.7-ms delay will occur before entering the start state. If the PEN bit is set, the state machine will step through the proximity states of proximity accumulate and then proximity ADC conversion. As soon as the conversion is complete, the state machine will move to the following state.

If the WEN bit is set, the state machine will then cycle through the wait state. If the WLONG bit is set, the wait cycles are extended by 12× over normal operation. When the wait counter terminates, the state machine will step to the ALS state.

The AEN should always be set, even in proximity-only operation. In this case, a minimum of 1 integration time step should be programmed. The ALS state machine will continue until it reaches the terminal count at which point the data will be latched in the ALS register and the interrupt set, if enabled.

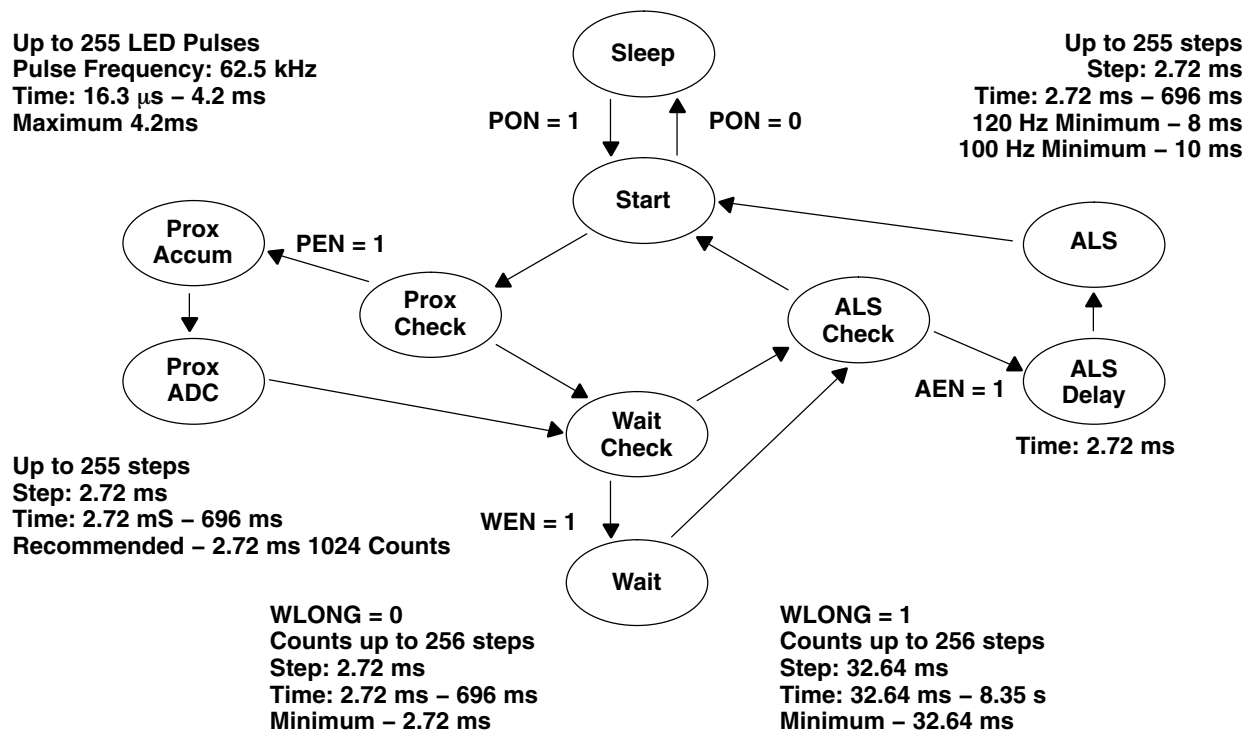
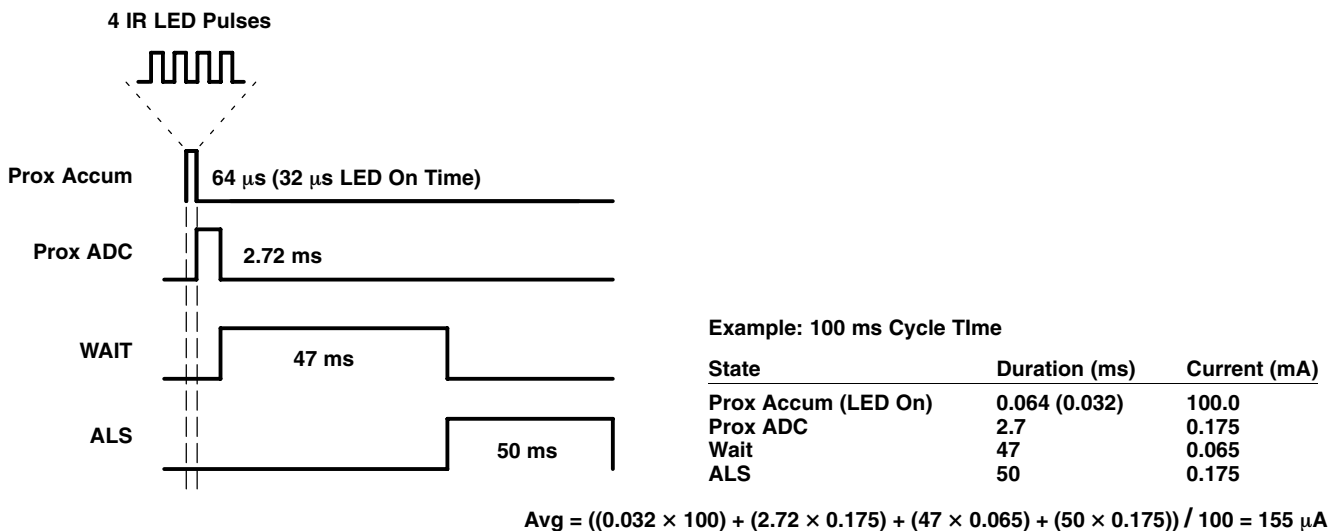

Figure 15. Expanded State Diagram



## Power Management

Power consumption can be controlled through the use of the wait state timing because the wait state consumes only 65  $\mu\text{A}$  of power. Figure 16 shows an example of using the power management feature to achieve an average power consumption of 155  $\mu\text{A}$  current with four 100-mA pulses of proximity detection and 50 ms of ALS detection. For I<sup>2</sup>C read and write transactions, if the PON bit is set to 0 the bit is overridden allowing the oscillator to be enabled.



**Figure 16. Power Consumption Calculations**

# TSL2771 LIGHT-TO-DIGITAL CONVERTER with PROXIMITY SENSING

TAOS100A – FEBRUARY 2010

---

## Basic Software Operation

The following pseudo code shows how to do basic initialization of the TSL2771.

```
unit8 ATIME, PIME, WTIME, PPCOUNT;
ATIME = 0xff;           // 2.72ms - minimum ALS integration time
WTIME = 0xff;           // 2.72ms - minimum Wait time
PTIME = 0xff;           // 2.72ms - minimum Prox integration time
PPCOUNT = 1;          // Minimum prox pulse count

WriteRegData(0, 0);     //Disable and Powerdown
WriteRegData (1, ATIME);
WriteRegData (2, PTIME);
WriteRegData (3, WTIME);
WriteRegData (0xe, PPCOUNT);

unit8 PDRIVE, PDIODE, PGAIN, AGAIN;
PDRIVE = 0;             //100mA of LED Power
PDIODE = 0x20;          // IR Diode
PGAIN = 0;              //1x Prox gain
AGAIN = 0;              //1x ALS gain

WriteRegData (0xf, PDRIVE | PDIODE | PGAIN | AGAIN);

unit8 WEN, PEN, AEN, PON;
WEN = 8;                // Enable Wait
PEN = 4;                // Enable Prox
AEN = 2;                // Enable ALS
PON = 1;                // Enable Power On
WriteRegData (0, WEN | PEN | AEN | PON);      // WriteRegData(0,0x0f);

Wait(12);                //Wait for 12 ms

int Clear_data, IR_data, Prox_data;

Clear_data = Read_Word(0x14);
IR_data = Read_Word(0x16);
Prox_data = Read_Word(0x18);

WriteRegData (unit8 reg, unit 8 data);
{
    m_I2CBus.WriteI2C(0x39, 0x80 | reg | &data);
}

unit16 Read_Word (unit8 reg);
{
    unit8 barr [2];
    m_I2CBus.ReadI2C(0x39, 0xA0 | reg, 2, ref barr);
    return (uint16)(barr[0] + 256 * barr[1]);
}
```

## I<sup>2</sup>C Protocol

Interface and control of the TSL2771 is accomplished through an I<sup>2</sup>C serial compatible interface (standard or fast mode) to a set of registers that provide access to device control functions and output data. The device supports a single slave address of 0x39 hex using 7-bit addressing protocol. (Contact factory for other addressing options.)

The I<sup>2</sup>C standard provides for three types of bus transaction: read, write, and a combined protocol (Figure 17). During a write operation, the first byte written is a command byte followed by data. In a combined protocol, the first byte written is the command byte followed by reading a series of bytes. If a read command is issued, the register address from the previous command will be used for data access. Likewise, if the MSB of the command is not set, the device will write a series of bytes at the address stored in the last valid command with a register address. The command byte contains either control information or a 5-bit register address. The control commands can also be used to clear interrupts.

For a complete description of I<sup>2</sup>C protocols, please review the I<sup>2</sup>C Specification at:

<http://www.semiconductors.philips.com>.

- A** Acknowledge (0)
- N** Not Acknowledged (1)
- P** Stop Condition
- R** Read (1)
- S** Start Condition
- S** Repeated Start Condition
- W** Write (0)
- ... Continuation of protocol
- Master-to-Slave
- Slave-to-Master

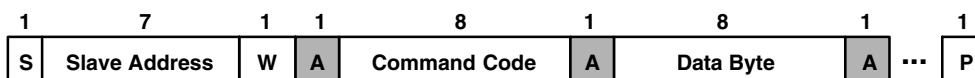

**I<sup>2</sup>C Write Protocol**



**I<sup>2</sup>C Read Protocol**

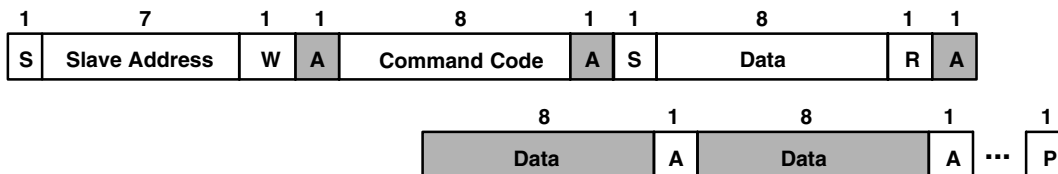

**I<sup>2</sup>C Read Protocol — Combined Format**

**Figure 17. I<sup>2</sup>C Protocols**

# TSL2771 LIGHT-TO-DIGITAL CONVERTER with PROXIMITY SENSING

TAOS100A – FEBRUARY 2010

## Register Set

The TSL2771 is controlled and monitored by data registers and a command register accessed through the serial interface. These registers provide for a variety of control functions and can be read to determine results of the ADC conversions. The register set is summarized in Table 1.

**Table 1. Register Address**

ADDRESS	REGISTER NAME	R/W	REGISTER FUNCTION	RESET VALUE
--	COMMAND	W	Specifies register address	0x00
0x00	ENABLE	R/W	Enables states and interrupts	0x00
0x01	ATIME	R/W	ALS ADC time	0xFF
0x02	PTIME	R/W	Proximity ADC time	0xFF
0x03	WTIME	R/W	Wait time	0xFF
0x04	AILTL	R/W	ALS interrupt low threshold low byte	0x00
0x05	AILTH	R/W	ALS interrupt low threshold high byte	0x00
0x06	AIHTL	R/W	ALS interrupt high threshold low byte	0x00
0x07	AIHTH	R/W	ALS interrupt high threshold high byte	0x00
0x08	PILTL	R/W	Proximity interrupt low threshold low byte	0x00
0x09	PILTH	R/W	Proximity interrupt low threshold high byte	0x00
0x0A	PIHTL	R/W	Proximity interrupt high threshold low byte	0x00
0x0B	PIHTH	R/W	Proximity interrupt high threshold high byte	0x00
0x0C	PERS	R/W	Interrupt persistence filters	0x00
0x0D	CONFIG	R/W	Configuration	0x00
0x0E	PPCOUNT	R/W	Proximity pulse count	0x00
0x0F	CONTROL	R/W	Gain control register	0x00
0x12	ID	R	Device ID	ID
0x13	STATUS	R	Device status	0x00
0x14	CDATA	R	Clear ADC low data register	0x00
0x15	CDATAH	R	Clear ADC high data register	0x00
0x16	IRDATA	R	IR ADC low data register	0x00
0x17	IRDATAH	R	IR ADC high data register	0x00
0x18	PDATA	R	Proximity ADC low data register	0x00
0x19	PDATAH	R	Proximity ADC high data register	0x00

The mechanics of accessing a specific register depends on the specific protocol used. See the section on I<sup>2</sup>C protocols on the previous pages. In general, the COMMAND register is written first to specify the specific control/status register for following read/write operations.

## Command Register

The command registers specifies the address of the target register for future write and read operations.

**Table 2. Command Register**

	7	6	5	4	3	2	1	0	
<b>COMMAND</b>	<b>COMMAND</b>	<b>TYPE</b>			<b>ADD</b>				--

FIELD	BITS	DESCRIPTION	
COMMAND	7	Select Command Register. Must write as 1 when addressing COMMAND register.	
TYPE	6:5	Selects type of transaction to follow in subsequent data transfers:	
		<b>FIELD VALUE</b>	<b>INTEGRATION TIME</b>
		00	Repeated byte protocol transaction
		01	Auto-increment protocol transaction
		10	Reserved — Do not use
		11	Special function — See description below
		Transaction type 00 will repeatedly read the same register with each data access. Transaction type 01 will provide an auto-increment function to read successive register bytes.	
ADD	4:0	Address register/special function register. Depending on the transaction type, see above, this field either specifies a special function command or selects the specific control-status-register for following write and read transactions:	
		<b>FIELD VALUE</b>	<b>READ VALUE</b>
		00000	Normal — no action
		00101	Proximity interrupt clear
		00110	ALS interrupt clear
		00111	Proximity and ALS interrupt clear
other	Reserved — Do not write		
		ALS/Proximity Interrupt Clear. Clears any pending ALS/Proximity interrupt. This special function is self clearing.	

# TSL2771 LIGHT-TO-DIGITAL CONVERTER with PROXIMITY SENSING

TAOS100A – FEBRUARY 2010

## Enable Register (0x00)

The ENABLE register is used to power the TSL2571 device on/off, enable functions, and interrupts.

**Table 3. Enable Register**

	7	6	5	4	3	2	1	0	
ENABLE	Reserved		PIEN	AIEN	WEN	PEN	AEN	PON	Address 0x00

FIELD	BITS	DESCRIPTION
Reserved	7:6	Reserved. Write as 0.
PIEN	5	Proximity interrupt mask. When asserted, permits proximity interrupts to be generated.
AIEN	4	ALS interrupt mask. When asserted, permits ALS interrupts to be generated.
WEN	3	Wait Enable. This bit activates the wait feature. Writing a 1 activates the wait timer. Writing a 0 disables the wait timer.
PEN	2	Proximity enable. This bit activates the proximity function. Writing a 1 enables proximity. Writing a 0 disables proximity.
AEN	1	ALS Enable. This bit activates the two channel ADC. Writing a 1 activates the ALS. Writing a 0 disables the ALS.
PON <sup>1,2</sup>	0	Power ON. This bit activates the internal oscillator to permit the timers and ADC channels to operate. Writing a 1 activates the oscillator. Writing a 0 disables the oscillator.

- NOTES: 1. See Power Management section for more information.  
 2. A minimum interval of 2.72 ms must pass after PON is asserted before either a proximity or ALS can be initiated. This required time is enforced by the hardware in cases where the firmware does not provide it.

### ALS Timing Register (0x01)

The ALS timing register controls the internal integration time of the ALS clear and IR channel ADCs in 2.72 ms increments.

**Table 4. ALS Timing Register**

FIELD	BITS	DESCRIPTION			
		VALUE	INTEG_CYCLES	TIME	MAX COUNT
ATIME	7:0	0xFF	1	2.72 ms	1024
		0xF6	10	27.2 ms	10240
		0xDB	37	100 ms	37888
		0xC0	64	174 ms	65535
		0x00	256	696 ms	65535

### Proximity Time Control Register (0x02)

The proximity timing register controls the integration time of the proximity ADC in 2.72 ms increments. It is recommended that this register be programmed to a value of 0xFF (1 cycle, 1024 bits).

**Table 5. Proximity Time Control Register**

FIELD	BITS	DESCRIPTION			
		VALUE	INTEG_CYCLES	TIME	MAX COUNT
PTIME	7:0	0xFF	1	2.72 ms	1024

### Wait Time Register (0x03)

Wait time is set 2.72 ms increments unless the WLONG bit is asserted in which case the wait times are 12X longer. WTIME is programmed as a 2's complement number.

**Table 6. Wait Time Register**

FIELD	BITS	DESCRIPTION			
		REGISTER VALUE	WAIT TIME	TIME (WLONG = 0)	TIME (WLONG = 1)
WTIME	7:0	0xFF	1	2.72 ms	0.032 sec
		0xB6	74	200 ms	2.4 sec
		0x00	256	700 ms	8.3sec

NOTE: The Proximity Wait Time Register should be configured before PEN and/or AEN is/are asserted.

**TSL2771**  
**LIGHT-TO-DIGITAL CONVERTER**  
**with PROXIMITY SENSING**

TAOS100A – FEBRUARY 2010

**ALS Interrupt Threshold Register (0x04 – 0x07)**

The ALS interrupt threshold registers provides the values to be used as the high and low trigger points for the comparison function for interrupt generation. If the value generated by the ALS channel crosses below the low threshold specified, or above the higher threshold, an interrupt is asserted on the interrupt pin.

**Table 7. ALS Interrupt Threshold Register**

REGISTER	ADDRESS	BITS	DESCRIPTION
AILTL	0x04	7:0	ALS clear channel low threshold lower byte
AILTH	0x05	7:0	ALS clear channel low threshold upper byte
AIHTL	0x06	7:0	ALS clear channel high threshold lower byte
AIHTH	0x07	7:0	ALS clear channel high threshold upper byte

**Proximity Interrupt Threshold Register (0x08 – 0x0B)**

The proximity interrupt threshold registers provide the values to be used as the high and low trigger points for the comparison function for interrupt generation. If the value generated by proximity channel crosses below the lower threshold specified, or above the higher threshold, an interrupt is signaled to the host processor.

**Table 8. Proximity Interrupt Threshold Register**

REGISTER	ADDRESS	BITS	DESCRIPTION
PILTL	0x08	7:0	Proximity ADC channel low threshold lower byte
PILTH	0x09	7:0	Proximity ADC channel low threshold upper byte
PIHTL	0x0A	7:0	Proximity ADC channel high threshold lower byte
PIHTH	0x0B	7:0	Proximity ADC channel high threshold upper byte



**Persistence Register (0x0C)**

The persistence register controls the filtering interrupt capabilities of the device. Configurable filtering is provided to allow interrupts to be generated after each ADC integration cycle or if the ADC integration has produced a result that is outside of the values specified by threshold register for some specified amount of time. Separate filtering is provided for proximity and ALS functions.

ALS interrupts are generated by looking only at the ADC integration results of CDATA.

**Table 9. Persistence Register**

	7	6	5	4	3	2	1	0	
<b>PERS</b>	<b>PPERS</b>						<b>APERS</b>		<b>Address 0x0C</b>

FIELD	BITS	DESCRIPTION		
PPERS	7:4	Proximity interrupt persistence. Controls rate of proximity interrupt to the host processor.		
		<b>FIELD VALUE</b>	<b>MEANING</b>	<b>INTERRUPT PERSISTENCE FUNCTION</b>
		0000	---	Every proximity cycle generates an interrupt
		0001	1	1 proximity value out of range
		0010	2	2 consecutive proximity values out of range
		...	...	...
1111	15	15 consecutive proximity values out of range		
APERS	3:0	Interrupt persistence. Controls rate of interrupt to the host processor.		
		<b>FIELD VALUE</b>	<b>MEANING</b>	<b>INTERRUPT PERSISTENCE FUNCTION</b>
		0000	Every	Every ALS cycle generates an interrupt
		0001	1	1 clear channel value outside of threshold range
		0010	2	2 clear channel consecutive values out of range
		0011	3	3 clear channel consecutive values out of range
		0100	5	5 clear channel consecutive values out of range
		0101	10	10 clear channel consecutive values out of range
		0110	15	15 clear channel consecutive values out of range
		0111	20	20 clear channel consecutive values out of range
		1000	25	25 clear channel consecutive values out of range
		1001	30	30 clear channel consecutive values out of range
		1010	35	35 clear channel consecutive values out of range
		1011	40	40 clear channel consecutive values out of range
		1100	45	45 clear channel consecutive values out of range
		1101	50	50 clear channel consecutive values out of range
1110	55	55 clear channel consecutive values out of range		
1111	60	60 clear channel consecutive values out of range		

**TSL2771**  
**LIGHT-TO-DIGITAL CONVERTER**  
**with PROXIMITY SENSING**

TAOS100A – FEBRUARY 2010

**Configuration Register (0x0D)**

The configuration register sets the wait long time.

**Table 10. Configuration Register**

	7	6	5	4	3	2	1	0	
CONFIG	Reserved						WLONG	Reserved	Address 0x0D
FIELD	BITS	DESCRIPTION							
Reserved	7:2	Reserved. Write as 0.							
WLONG	1	Wait Long. When asserted, the wait cycles are increased by a factor 12X from that programmed in the WTIME register.							
Reserved	0	Reserved. Write as 0.							

**Proximity Pulse Count Register (0x0E)**

The proximity pulse count register sets the number of proximity pulses that will be transmitted. When proximity detection is enabled, a proximity detect cycle occurs after each ALS cycle. PPULSE defines the number of pulses to be transmitted at a 62.5-kHz rate.

**NOTE:** The ATIME register will be used to time the interval between proximity detection events even if the ALS function is disabled.

**Table 11. Proximity Pulse Count Register**

	7	6	5	4	3	2	1	0	
PPULSE	PPULSE								Address 0x0E
FIELD	BITS	DESCRIPTION							
PPULSE	7:0	Proximity Pulse Count. Specifies the number of proximity pulses to be generated.							

### Control Register (0x0F)

The Control register provides eight bits of miscellaneous control to the analog block. These bits typically control functions such as gain settings and/or diode selection.

**Table 12. Gain Register**

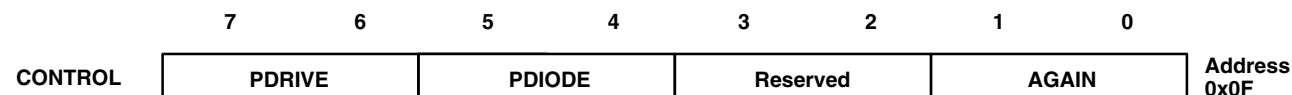

FIELD	BITS	DESCRIPTION	
PDRIVE	7:6	LED Drive Strength.	
		<b>FIELD VALUE</b>	<b>LED STRENGTH</b>
		00	100 mA
		01	50 mA
		10	25 mA
		11	12.5 mA
PDIODE	5:4	Proximity Diode Select.	
		<b>FIELD VALUE</b>	<b>DIODE SELECTION</b>
		00	Reserved
		01	Proximity uses the clear (broadband) diode
		10	Proximity uses the IR diode
		11	Proximity uses both the clear diode and the IR 1 diode
Reserved	3:2	Reserved. Write bits as zero (0:0)	
AGAIN	1:0	ALS Gain Control.	
		<b>FIELD VALUE</b>	<b>ALS GAIN VALUE</b>
		00	1× gain
		01	8× gain
		10	16× gain
		11	120× gain

### ID Register (0x12)

The ID Register provides the value for the part number. The ID register is a read-only register.

**Table 13. ID Register**

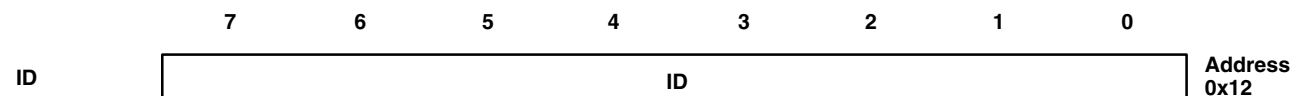

FIELD	BITS	DESCRIPTION	
ID	7:0	Part number identification	0x00 = TSL27711
			0x08 = TSL27713



# TSL2771 LIGHT-TO-DIGITAL CONVERTER with PROXIMITY SENSING

TAOS100A – FEBRUARY 2010

## Status Register (0x13)

The Status Register provides the internal status of the device. This register is read only.

**Table 14. Status Register**

	7	6	5	4	3	2	1	0	
STATUS	Reserved		PINT	AINT	Reserved		AVALID		Address 0x13

FIELD	BIT	DESCRIPTION
Reserved	7:6	Reserved.
PINT	5	Proximity Interrupt. Indicates that the device is asserting a proximity interrupt.
AINT	4	ALS Interrupt. Indicates that the device is asserting an ALS interrupt.
Reserved	3:1	Reserved.
AVALID	0	ALS Valid. Indicates that the ALS clear / IR channels have completed an integration cycle.

## ADC Channel Data Registers (0x14 – 0x17)

ALS clear and IR data are stored as two 16-bit values. To ensure the data is read correctly, a two-byte read I<sup>2</sup>C transaction should be used with auto increment protocol bits set in the command register. With this operation, when the lower byte register is read, the upper eight bits are stored in a shadow register, which is read by a subsequent read to the upper byte. The upper register will read the correct value even if additional ADC integration cycles end between the reading of the lower and upper registers.

**Table 15. ADC Channel Data Registers**

REGISTER	ADDRESS	BITS	DESCRIPTION
CDATAL	0x14	7:0	ALS clear data low byte
CDATAH	0x15	7:0	ALS clear data high byte
IRDATAH	0x16	7:0	ALS IR data low byte
IRDATAL	0x17	7:0	ALS IR data high byte

## Proximity Data Register (0x18 – 0x19h)

Proximity data is stored as a 16-bit value. To ensure the data is read correctly, a two-byte read I<sup>2</sup>C transaction should be utilized with auto increment protocol bits set in the command register. With this operation, when the lower byte register is read, the upper eight bits are stored into a shadow register, which is read by a subsequent read to the upper byte. The upper register will read the correct value even if the next ADC cycle ends between the reading of the lower and upper registers.

**Table 16. PDATA Registers**

REGISTER	ADDRESS	BITS	DESCRIPTION
PDATAH	0x18	7:0	Proximity data low byte
PDATAL	0x19	7:0	Proximity data high byte

**APPLICATION INFORMATION: HARDWARE**

**LED Driver Pin with Proximity Detection**

The application hardware circuit with proximity detection requires an LED connected as shown in Figure 18.  $V_{bat}$  may be an independent power source. If  $V_{bat} = V_{dd}$  (same source), however, tie the two power lines together as close to the source as possible.

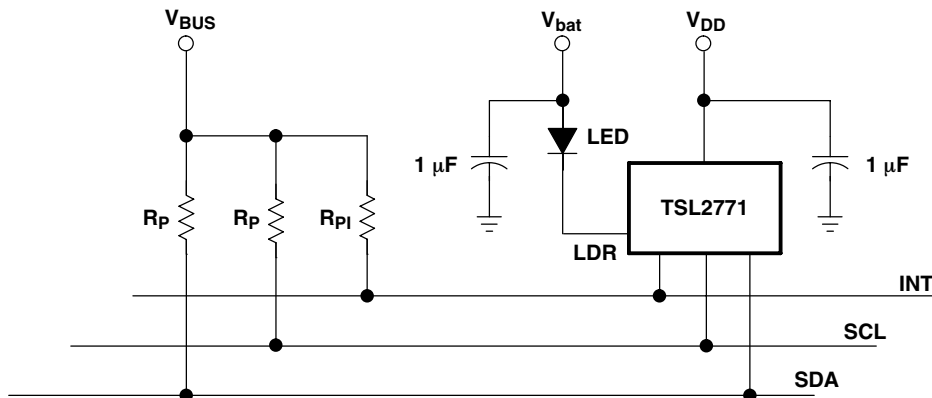

**Figure 18. Application Hardware Circuit for Proximity Sensing with Internal LED Driver**

If the hardware application requires more than 100 mA of current to drive the LED, then an external transistor should be used. Note, R2 should be sized adequately to bias the gate voltage given the LDR current mode setting. See Figure 19.

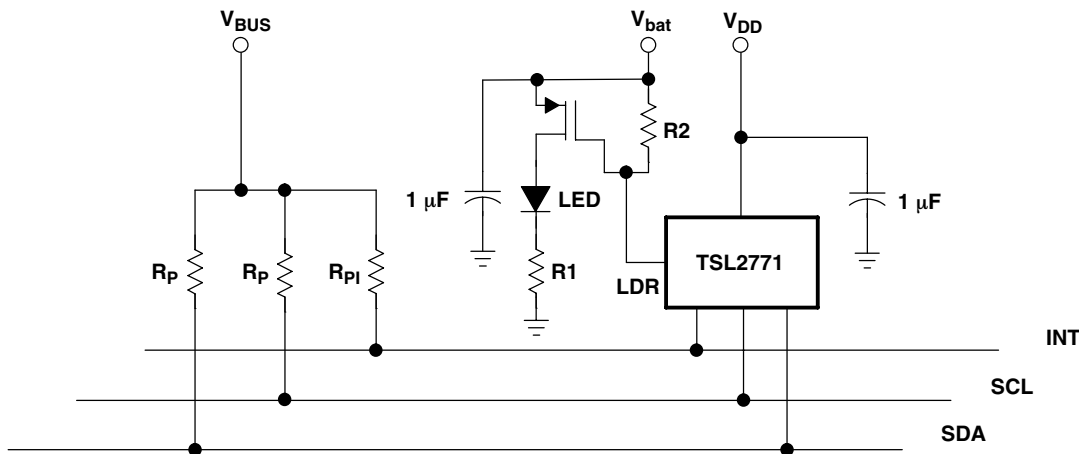

**Figure 19. Application Hardware Circuit for Proximity Sensing with External LED Driver Using P-FET Transistor**

# TSL2771 LIGHT-TO-DIGITAL CONVERTER with PROXIMITY SENSING

TAOS100A – FEBRUARY 2010

## APPLICATION INFORMATION: HARDWARE

### PCB Pad Layout

Suggested PCB pad layout guidelines for the Dual Flat No-Lead (FN) surface mount package are shown in Figure 20.

Note: Pads can be extended further if hand soldering is needed.

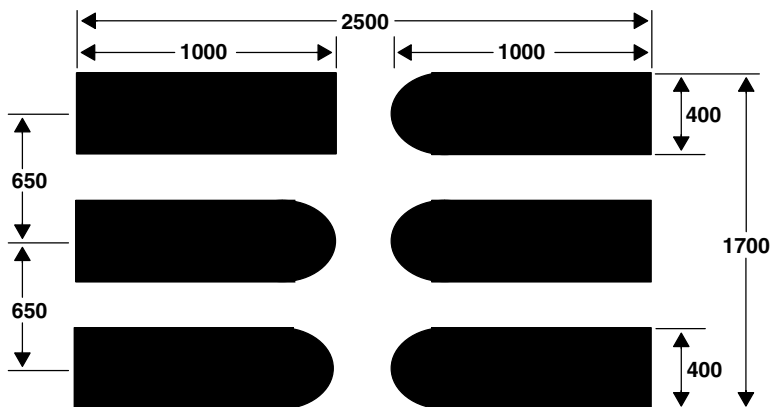

- NOTES: A. All linear dimensions are in micrometers.  
B. This drawing is subject to change without notice.

Figure 20. Suggested FN Package PCB Layout

**MECHANICAL DATA**

**PACKAGE FN**

**Dual Flat No-Lead**

**TOP VIEW**

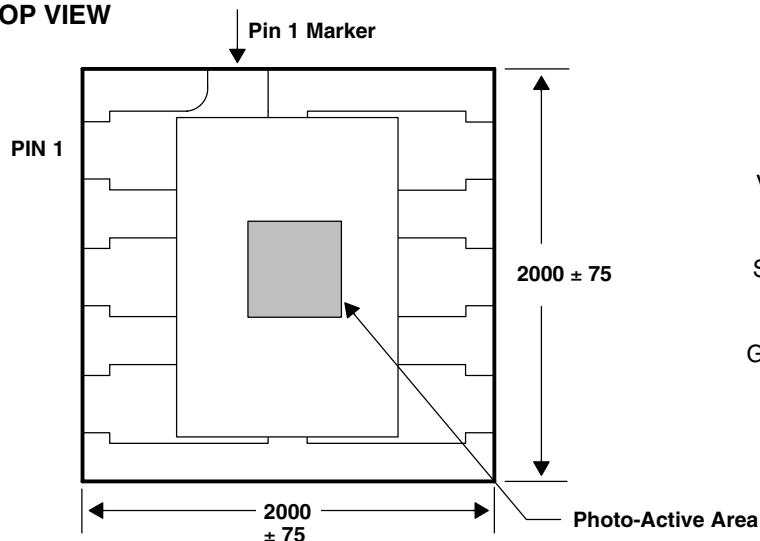

**PIN OUT TOP VIEW**

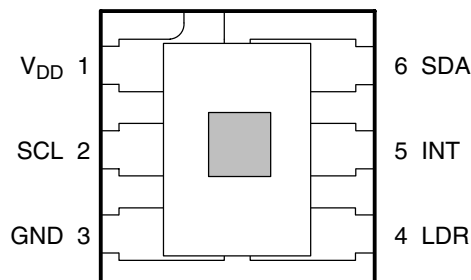

**END VIEW**



**SIDE VIEW**

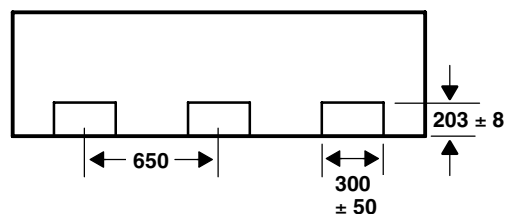

**BOTTOM VIEW**

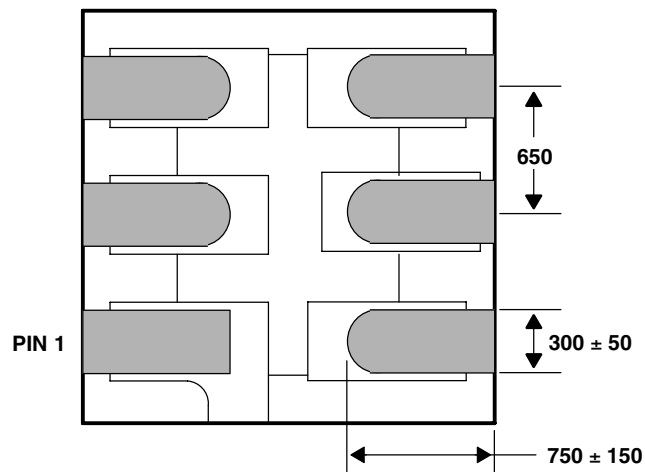

**Lead Free**

- NOTES: A. All linear dimensions are in micrometers. Dimension tolerance is ± 20 μm unless otherwise noted.  
 B. The photodiode active area is 466 μm square and its center is 140 μm above and 20 μm to the right of the package center. The die placement tolerance is ± 75 μm in any direction.  
 C. Package top surface is molded with an electrically nonconductive clear plastic compound having an index of refraction of 1.55.  
 D. Contact finish is copper alloy A194 with pre-plated NiPdAu lead finish.  
 E. This package contains no lead (Pb).  
 F. This drawing is subject to change without notice.

**Figure 21. Package FN — Dual Flat No-Lead Packaging Configuration**

**TSL2771**  
**LIGHT-TO-DIGITAL CONVERTER**  
**with PROXIMITY SENSING**

TAOS100A – FEBRUARY 2010

**MECHANICAL DATA**

**TOP VIEW**

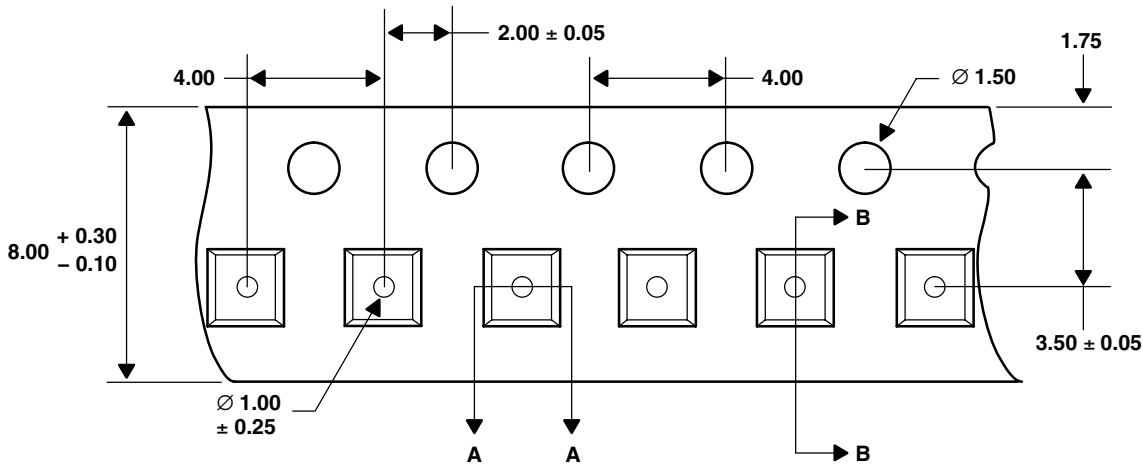

**DETAIL A**

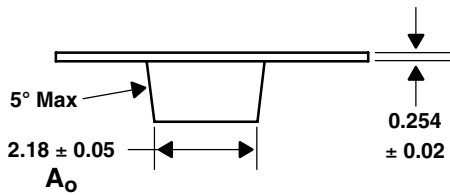

**DETAIL B**

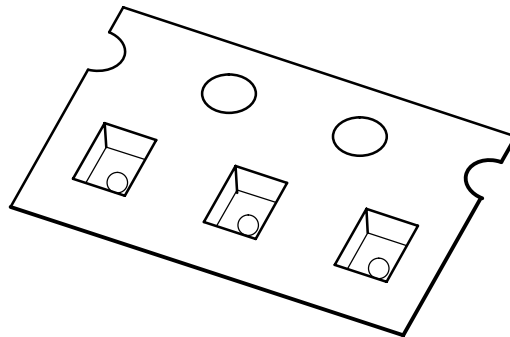
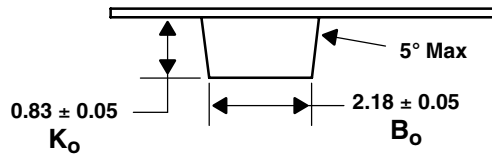

- NOTES: A. All linear dimensions are in millimeters. Dimension tolerance is  $\pm 0.10$  mm unless otherwise noted.  
 B. The dimensions on this drawing are for illustrative purposes only. Dimensions of an actual carrier may vary slightly.  
 C. Symbols on drawing  $A_0$ ,  $B_0$ , and  $K_0$  are defined in ANSI EIA Standard 481-B 2001.  
 D. Each reel is 178 millimeters in diameter and contains 3500 parts.  
 E. TAOS packaging tape and reel conform to the requirements of EIA Standard 481-B.  
 F. In accordance with EIA standard, device pin 1 is located next to the sprocket holes in the tape.  
 G. This drawing is subject to change without notice.

**Figure 22. Package FN Carrier Tape**



**MANUFACTURING INFORMATION**

The FN package has been tested and has demonstrated an ability to be reflow soldered to a PCB substrate. The process, equipment, and materials used in these test are detailed below.

The solder reflow profile describes the expected maximum heat exposure of components during the solder reflow process of product on a PCB. Temperature is measured on top of component. The components should be limited to a maximum of three passes through this solder reflow profile.

**Table 17. TSL2771 Solder Reflow Profile**

PARAMETER	REFERENCE	TSL2771
Average temperature gradient in preheating		2.5°C/sec
Soak time	$t_{soak}$	2 to 3 minutes
Time above 217°C	$t_1$	Max 60 sec
Time above 230°C	$t_2$	Max 50 sec
Time above $T_{peak} - 10^\circ\text{C}$	$t_3$	Max 10 sec
Peak temperature in reflow	$T_{peak}$	260°C
Temperature gradient in cooling		Max -5°C/sec

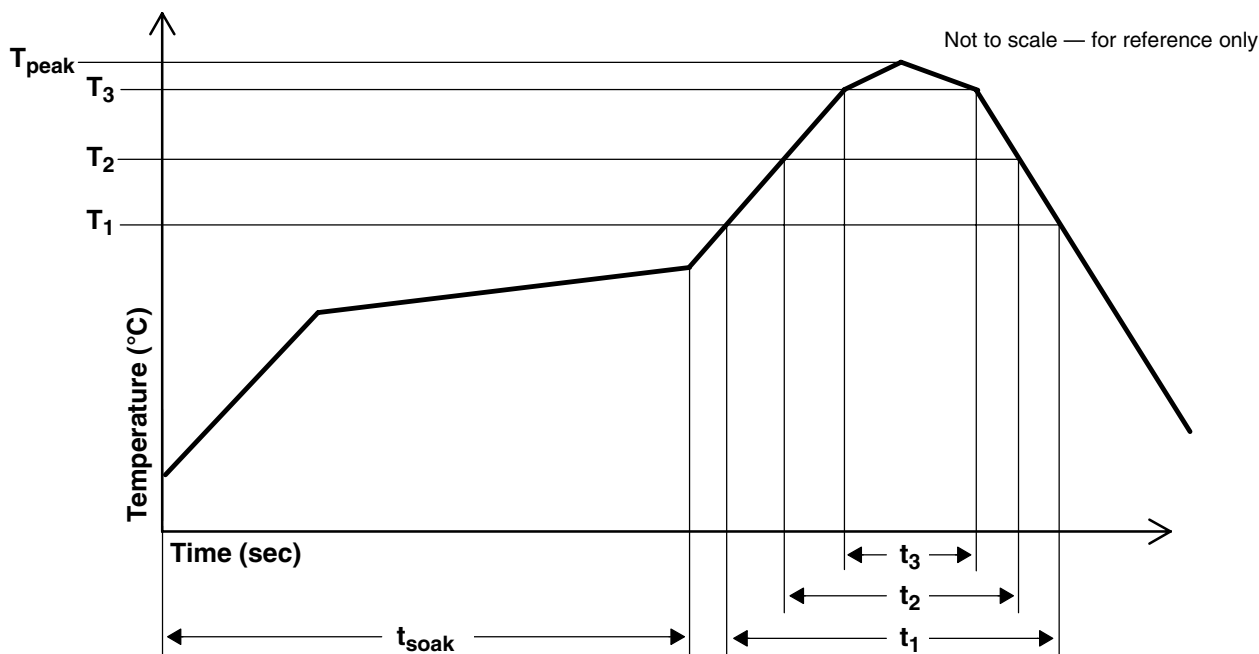

**Figure 23. TSL2771 Solder Reflow Profile Graph**

## MANUFACTURING INFORMATION

### Moisture Sensitivity

Optical characteristics of the device can be adversely affected during the soldering process by the release and vaporization of moisture that has been previously absorbed into the package. To ensure the package contains the smallest amount of absorbed moisture possible, each device is dry-baked prior to being packed for shipping. Devices are packed in a sealed aluminized envelope called a moisture barrier bag with silica gel to protect them from ambient moisture during shipping, handling, and storage before use.

The Moisture Barrier Bags should be stored under the following conditions:

Temperature Range	< 40°C
Relative Humidity	< 90%
Total Time	No longer than 12 months from the date code on the aluminized envelope if unopened.

Rebaking of the reel will be required if the devices have been stored unopened for more than 12 months and the Humidity Indicator Card shows the parts to be out of the allowable moisture region.

Opened reels should be used within 168 hours if exposed to the following conditions:

Temperature Range	< 30°C
Relative Humidity	< 60%

If rebaking is required, it should be done at 50°C for 12 hours.

The FN package has been assigned a moisture sensitivity level of MSL 3.

**PRODUCTION DATA** — information in this document is current at publication date. Products conform to specifications in accordance with the terms of Texas Advanced Optoelectronic Solutions, Inc. standard warranty. Production processing does not necessarily include testing of all parameters.

### ***LEAD-FREE (Pb-FREE) and GREEN STATEMENT***

**Pb-Free (RoHS)** TAOS' terms *Lead-Free* or *Pb-Free* mean semiconductor products that are compatible with the current RoHS requirements for all 6 substances, including the requirement that lead not exceed 0.1% by weight in homogeneous materials. Where designed to be soldered at high temperatures, TAOS Pb-Free products are suitable for use in specified lead-free processes.

**Green (RoHS & no Sb/Br)** TAOS defines *Green* to mean Pb-Free (RoHS compatible), and free of Bromine (Br) and Antimony (Sb) based flame retardants (Br or Sb do not exceed 0.1% by weight in homogeneous material).

**Important Information and Disclaimer** The information provided in this statement represents TAOS' knowledge and belief as of the date that it is provided. TAOS bases its knowledge and belief on information provided by third parties, and makes no representation or warranty as to the accuracy of such information. Efforts are underway to better integrate information from third parties. TAOS has taken and continues to take reasonable steps to provide representative and accurate information but may not have conducted destructive testing or chemical analysis on incoming materials and chemicals. TAOS and TAOS suppliers consider certain information to be proprietary, and thus CAS numbers and other limited information may not be available for release.

### **NOTICE**

Texas Advanced Optoelectronic Solutions, Inc. (TAOS) reserves the right to make changes to the products contained in this document to improve performance or for any other purpose, or to discontinue them without notice. Customers are advised to contact TAOS to obtain the latest product information before placing orders or designing TAOS products into systems.

TAOS assumes no responsibility for the use of any products or circuits described in this document or customer product design, conveys no license, either expressed or implied, under any patent or other right, and makes no representation that the circuits are free of patent infringement. TAOS further makes no claim as to the suitability of its products for any particular purpose, nor does TAOS assume any liability arising out of the use of any product or circuit, and specifically disclaims any and all liability, including without limitation consequential or incidental damages.

TEXAS ADVANCED OPTOELECTRONIC SOLUTIONS, INC. PRODUCTS ARE NOT DESIGNED OR INTENDED FOR USE IN CRITICAL APPLICATIONS IN WHICH THE FAILURE OR MALFUNCTION OF THE TAOS PRODUCT MAY RESULT IN PERSONAL INJURY OR DEATH. USE OF TAOS PRODUCTS IN LIFE SUPPORT SYSTEMS IS EXPRESSLY UNAUTHORIZED AND ANY SUCH USE BY A CUSTOMER IS COMPLETELY AT THE CUSTOMER'S RISK.

LUMENOLOGY, TAOS, the TAOS logo, and Texas Advanced Optoelectronic Solutions are registered trademarks of Texas Advanced Optoelectronic Solutions Incorporated.

**TSL2771**  
**LIGHT-TO-DIGITAL CONVERTER**  
**with PROXIMITY SENSING**

TAOS100A – FEBRUARY 2010

---

# Mouser Electronics

Authorized Distributor

Click to View Pricing, Inventory, Delivery & Lifecycle Information:

[ams OSRAM:](#)

[TSL27711FN](#) [TSL27713FN](#)