

# TSL2581, TSL2583

## Light-to-Digital Converter

### General Description

The TSL2581 and TSL2583 are very-high sensitivity light-to-digital converters that transform light intensity to a digital signal output capable of direct I<sup>2</sup>C interface. Each device combines one broadband photodiode (visible plus infrared) and one infrared-responding photodiode on a single CMOS integrated circuit capable of providing a near-photopic response over an effective 16-bit dynamic range (16-bit resolution). Two integrating ADCs convert the photodiode currents to a digital output that represents the irradiance measured on each channel. This digital output can be input to a microprocessor where illuminance (ambient light level) in lux is derived using an empirical formula to approximate the human eye response. The TSL2581 device supports a traditional level style interrupt that remains asserted until the firmware clears it.

While useful for general purpose light sensing applications, the TSL2581/83 devices are designed particularly for displays (LCD, OLED, etc.) with the purpose of extending battery life and providing optimum viewing in diverse lighting conditions. Display panel backlighting, which can account for up to 50 to 60 percent of total platform power, can be automatically managed. Both devices are also ideal for controlling keyboard illumination based upon ambient lighting conditions. Illuminance information can further be used to manage exposure control in digital cameras. The TSL2581/83 devices are ideal in notebook/tablet PCs, LCD monitors, flat-panel televisions, cell phones, and digital cameras. In addition, other applications include street light control, security lighting, sunlight harvesting, machine vision, and automotive instrumentation clusters.

*[Ordering Information](#) and [Content Guide](#) appear at end of datasheet.*

## Key Benefits & Features

The benefits and features of TSL2581, TSL2583, Light-to-Digital Converter are listed below:

**Figure 1:**  
**Added Value Of Using TSL2581, TSL2583**

Benefits	Features
<ul style="list-style-type: none"> <li>Enables Operation in IR Light Environments</li> </ul>	<ul style="list-style-type: none"> <li>Patented Dual-Diode Architecture</li> </ul>
<ul style="list-style-type: none"> <li>Enables Dark Room to High Lux Sunlight Operation</li> </ul>	<ul style="list-style-type: none"> <li>Programmable Analog Gain and Integration Time Supporting 1,000,000-to-1 Dynamic Range</li> </ul>
<ul style="list-style-type: none"> <li>Digital Interface is Less Susceptible to Noise</li> </ul>	<ul style="list-style-type: none"> <li>I<sup>2</sup>C Digital Interface</li> </ul>
<ul style="list-style-type: none"> <li>Enables Low Standby Power Consumption</li> </ul>	<ul style="list-style-type: none"> <li>Low Quiescent Current 3μA in Power Down Mode</li> </ul>
<ul style="list-style-type: none"> <li>Reduces Board Space Requirements while Simplifying Designs</li> </ul>	<ul style="list-style-type: none"> <li>Available in Ultra-Small 1.25 mm × 1.75 mm Chip-scale Package and Small 2 mm × 2 mm Flat No-Lead Package</li> </ul>

- 30x More Sensitive Than the TSL2560/61 Device
- Approximates Human Eye Response
- Programmable ALS Interrupt Function with User-Defined Upper and Lower Threshold Settings
- 16-Bit Digital Output with I<sup>2</sup>C Fast-Mode at 400 kHz
- Automatically Rejects 50/60-Hz Lighting Ripple

## Applications

TSL2581, TSL2583, Light-to-Digital Converter is ideal for Ambient Light Sensor (ALS) for Display Brightness Control

## End Products and Market Segments

- HDTVs
- Laptops and Tablets
- Mobile Handsets
- Monitors

### Block Diagram

The functional blocks of this device are shown below:

**Figure 2:**  
TSL2581, TSL2583 Block Diagram

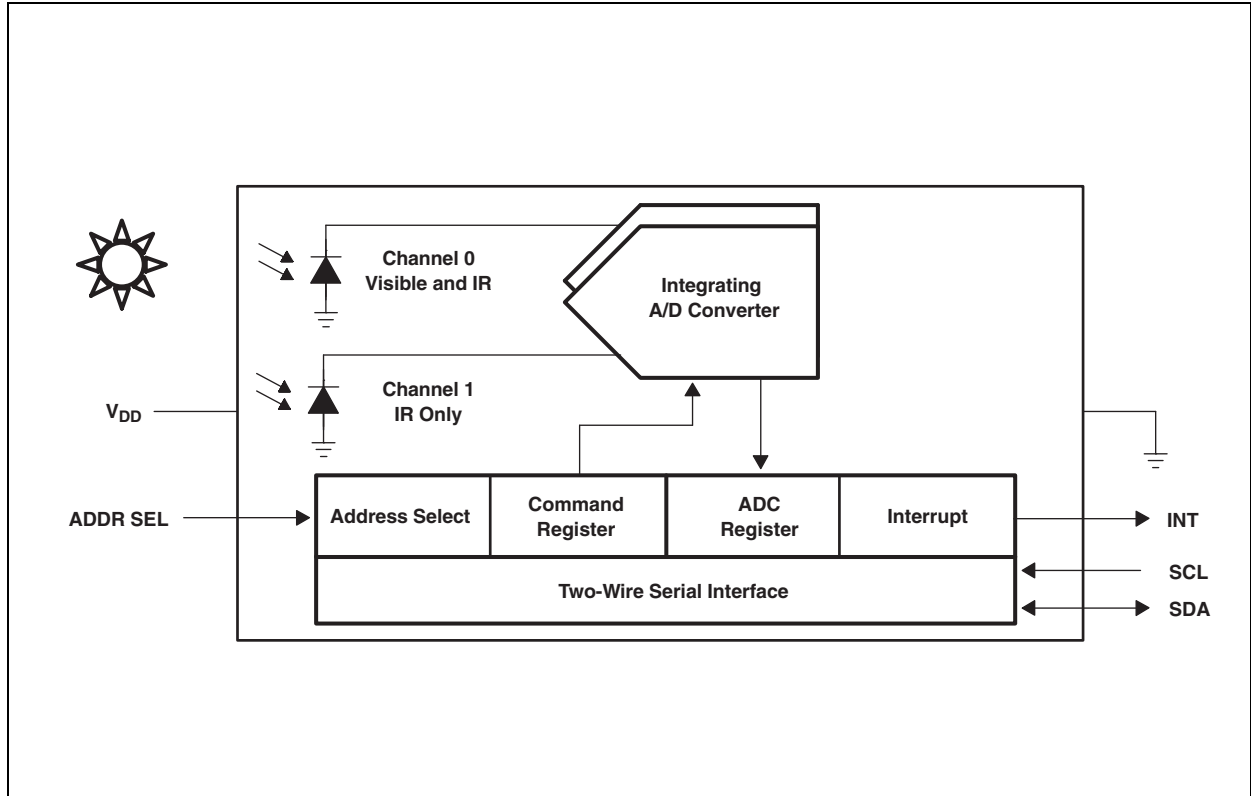

## Pin Assignments

**Figure 3:**  
Package CS 6-Lead Chipscale (Top View)

**Package CS 6-Lead Chipscale:**  
Package Drawings are Not to Scale

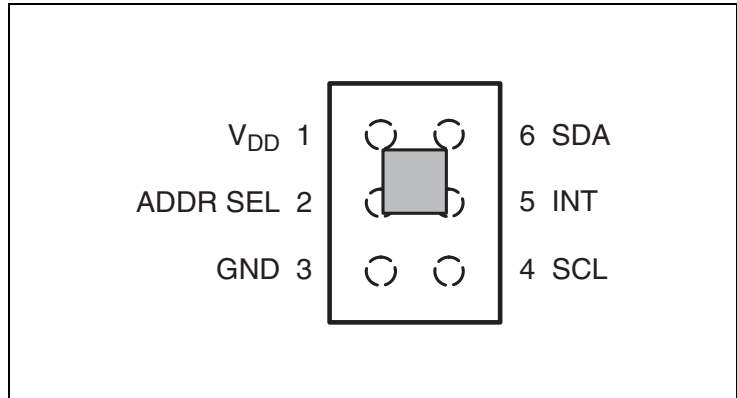

**Figure 4:**  
Package FN Dual Flat No-Lead (Top View)

**Package FN Dual Flat No-Lead:**  
Package Drawings are Not to Scale

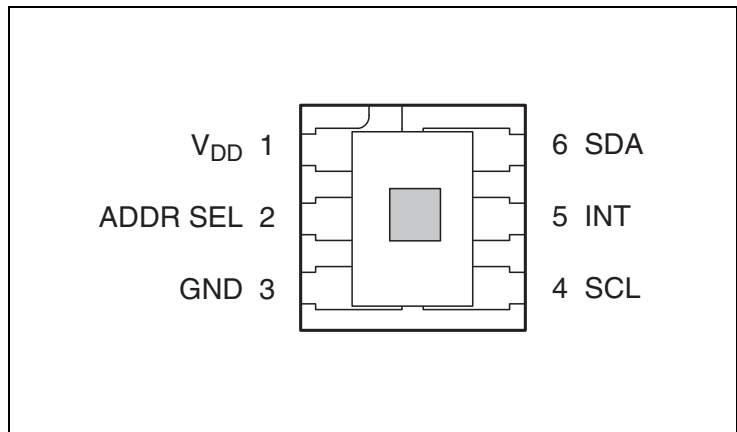

**Figure 5:**  
Terminal Functions

Terminal		Type	Description
Name	No		
V <sub>DD</sub>	1		Supply voltage
ADDR SEL	2	I	Address select — three-state
GND	3		Power supply ground. All voltages are referenced to GND.
SCL	4	I	Serial clock input terminal — clock signal
INT	5	O	Interrupt — open drain
SDA	6	I/O	Serial data I/O terminal — serial data I/O

## Detailed Description

The TSL2581 and TSL2583 are second-generation ambient light sensor devices. Each contains two integrating analog-to-digital converters (ADC) that integrate currents from two photodiodes. Integration of both channels occurs simultaneously. Upon completion of the conversion cycle, the conversion result is transferred to the Channel 0 and Channel 1 data registers, respectively. The transfers are double-buffered to ensure that the integrity of the data is maintained. After the transfer, the device automatically begins the next integration cycle.

Communication to the device is accomplished through a standard, two-wire I<sup>2</sup>C serial bus. Consequently, the TSL258x device can be easily connected to a microcontroller or embedded controller. No external circuitry is required for signal conditioning, thereby saving PCB real estate as well. Because the output of the TSL258x device is digital, the output is effectively immune to noise when compared to an analog signal.

The TSL258x devices also support an interrupt feature that simplifies and improves system efficiency by eliminating the need to poll a sensor for a light intensity value. The primary purpose of the interrupt function is to detect a meaningful change in light intensity. The concept of a *meaningful change* can be defined by the user both in terms of light intensity and time, or persistence, of that change in intensity. The TSL258x devices have the ability to define a threshold above and below the current light level. An interrupt is generated when the value of a conversion exceeds either of these limits.

## Absolute Maximum Ratings

Stresses beyond those listed under [Absolute Maximum Ratings](#) may cause permanent damage to the device. These are stress ratings only, and functional operation of the device at these or any other conditions beyond those indicated under [Recommended Operating Conditions](#) is not implied. Exposure to absolute-maximum-rated conditions for extended periods may affect device reliability.

**Figure 6:**  
**Absolute Maximum Ratings Over Operating Free-Air Temperature Range (unless otherwise noted)**

Symbol	Parameter	Min	Max	Units
$V_{DD}^{(1)}$	Supply voltage		3.8	V
$V_O$	Digital output voltage range	-0.5	3.8	V
$I_O$	Digital output current	-1	20	mA
$T_{STRG}$	Storage temperature range	-40	85	°C
$ESD_{HBM}$	ESD tolerance, human body model	±2000		V

**Note(s):**

1. All voltages are with respect to GND.

## Electrical Characteristics

**Figure 7:**  
Recommended Operating Conditions

Symbol	Parameter	Min	Nom	Max	Unit
$V_{DD}$	Supply voltage	2.7	3	3.6	V
$T_A$	Operating free-air temperature	-30		70	°C
$V_{IL}$	SCL, SDA input low voltage	TSL2581 <sup>(1)</sup>		$0.3 V_{DD}$	V
		TSL2583 <sup>(2)</sup>		0.54	
$V_{IH}$	SCL, SDA input high voltage	TSL2581 <sup>(1)</sup>	$0.7 V_{DD}$		V
		TSL2583 <sup>(2)</sup>	1.25		

**Note(s):**

1. Meets I<sup>2</sup>C specifications where  $V_{BUS} = V_{DD}$ .
2. Meets I<sup>2</sup>C specifications where  $V_{BUS} = 1.8$  V.

**Figure 8:**  
Electrical Characteristics Over Recommended Operating Free-Air Temperature Range

Symbol	Parameter	Test Conditions	Min	Typ	Max	Unit
$I_{DD}$	Supply current	Active		175	250	μA
		Power down — I <sup>2</sup> C activity		3	10	μA
$V_{OL}$	INT, SDA output low voltage	3mA sink current	0		0.4	V
		6mA sink current	0		0.6	V
$I_{LEAK}$	Leakage current		-5		5	μA

**Figure 9:**  
**Operating Characteristics;  $V_{DD} = 3\text{ V}$ ,  $T_A = 25^\circ\text{C}$  (unless otherwise noted) (1) (2) (3) (4)**

Parameter	Test Conditions	Channel	Min	Typ	Max	Unit
$f_{osc}$ Oscillator frequency			705	750	795	kHz
Dark ADC count value	$E_e = 0$ , ATIME = 0xB6 (200 ms), gain=16X	CH0	0	1	5	counts
		CH1	0	1	5	
Full scale ADC count value	ATIME = 0xDB (100 ms)	CH0			37887	counts
		CH1			37887	
	ATIME = 0x6C (400 ms)	CH0			65535	
		CH1			65535	
ADC count value	$\lambda_p = 625\text{ nm}$ , ATIME = 0xF6 (27 ms), $E_e = 171.6\ \mu\text{W}/\text{cm}^2$ , gain = 16X	CH0	4000	5000	6000	counts
		CH1		700		
	$\lambda_p = 850\text{ nm}$ , ATIME = 0xF6 (27 ms), $E_e = 220\ \mu\text{W}/\text{cm}^2$ , gain = 16X	CH0	4000	5000	6000	
		CH1		2750		
ADC count value ratio: CH1/CH0	$\lambda_p = 625\text{ nm}$		10.8	15.8	20.8	%
	$\lambda_p = 850\text{ nm}$		41	55	68	
$R_e$ Irradiance responsivity	$\lambda_p = 625\text{ nm}$ , ATIME = 0xF6 (27 ms)	CH0		29.1		counts/ ( $\mu\text{W}/\text{cm}^2$ )
		CH1		4		
	$\lambda_p = 850\text{ nm}$ , ATIME = 0xF6 (27 ms)	CH0		22.8		
		CH1		12.5		
Gain scaling (relative to 1x)	8x	CH0	7	8	9	x
		CH1	7	8	9	
	16x	CH0	15	16	17	
		CH1	15	16	17	
	111x, decoupling capacitor 25 mm from $V_{DD}$ pin (5)	CH0	97	107	115	
		CH1	100	115	125	

**Note(s):**

- Optical measurements are made using small-angle incident radiation from light-emitting diode optical sources. Visible 640 nm LEDs and infrared 850 nm LEDs are used for final product testing for compatibility with high-volume production.
- The 625 nm irradiance  $E_e$  is supplied by an AlInGaP light-emitting diode with the following characteristics: peak wavelength  $\lambda_p = 625\text{ nm}$  and spectral halfwidth  $\Delta\lambda_{1/2} = 20\text{ nm}$ .
- The 850 nm irradiance  $E_e$  is supplied by a light-emitting diode with the following characteristics: peak wavelength  $\lambda_p = 850\text{ nm}$  and spectral halfwidth  $\Delta\lambda_{1/2} = 42\text{ nm}$ .



4. The integration time  $T_{int}$  is dependent on internal oscillator frequency ( $f_{osc}$ ) and on the number of integration cycles (ATIME) in the Timing Register (0xFF) as described in the Register section. For nominal  $f_{osc} = 750$  kHz, nominal  $T_{int} = 2.7$  ms  $\times$  ATIME.
5. 111x gain is affected by the line inductance between the  $V_{DD}$  pin and the decoupling capacitor. See Figure 3 for 111x gain scale versus line inductance characteristic.

**Figure 10:**  
AC Electrical Characteristics;  $V_{DD} = 3$  V,  $T_A = 25^\circ\text{C}$ , (unless otherwise noted)

Symbol	Parameter <sup>(1)</sup>	Test Conditions	Min	Typ	Max	Unit
$t_{(CONV)}$	Conversion time		2.7		688	ms
$f_{(SCL)}$	Clock frequency		0		400	kHz
$t_{(BUF)}$	Bus free time between start and stop condition		1.3			$\mu\text{s}$
$t_{(HDSTA)}$	Hold time after (repeated) start condition. After this period, the first clock is generated.		0.6			$\mu\text{s}$
$t_{(SUSTA)}$	Repeated start condition setup time		0.6			$\mu\text{s}$
$t_{(SUSTO)}$	Stop condition setup time		0.6			$\mu\text{s}$
$t_{(HDDAT)}$	Data hold time		0		0.9	$\mu\text{s}$
$t_{(SUDAT)}$	Data setup time		100			ns
$t_{(LOW)}$	SCL clock low period		1.3			$\mu\text{s}$
$t_{(HIGH)}$	SCL clock high period		0.6			$\mu\text{s}$
$t_F$	Clock/data fall time				300	ns
$t_R$	Clock/data rise time				300	ns
$C_i$	Input pin capacitance				10	pF

**Note(s):**

1. Specified by design and characterization; not production tested.

Parameter Measurement Information

Figure 11:  
Timing Diagrams

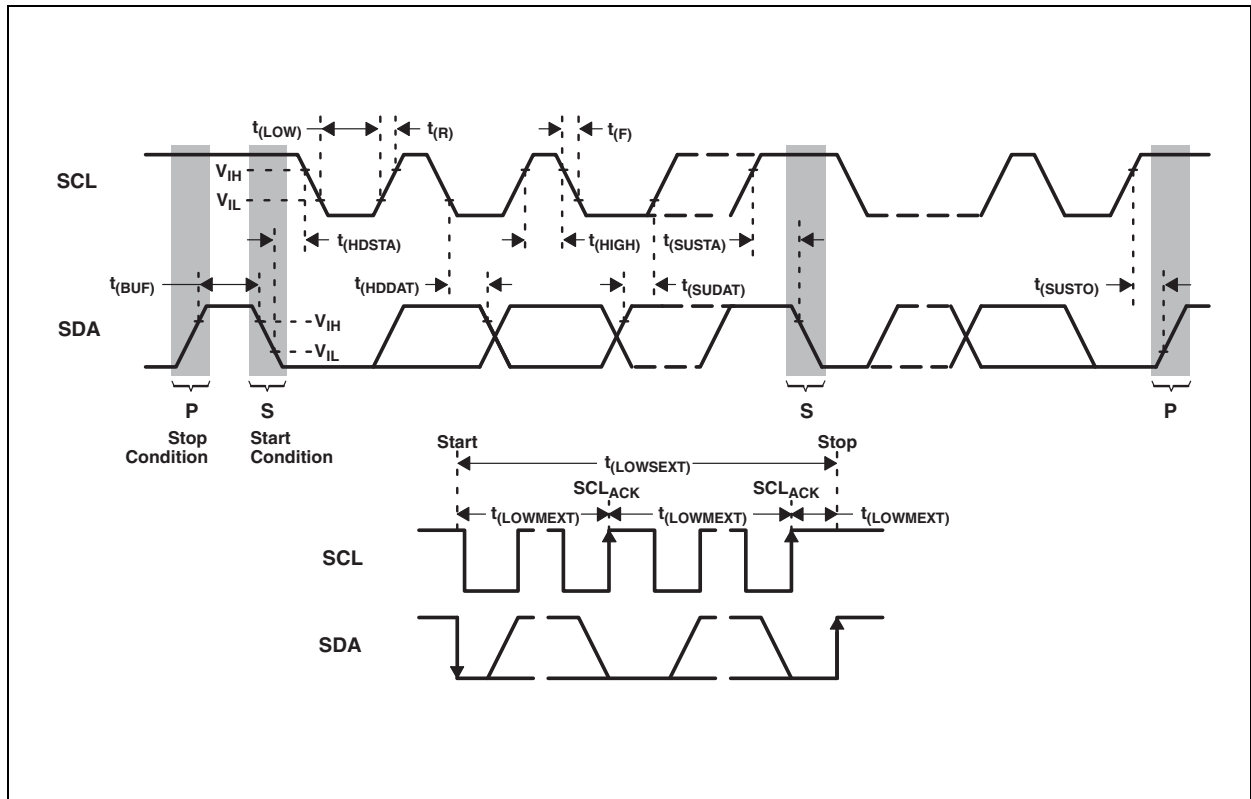

## Typical Characteristics

Figure 12:  
Spectral Responsivity

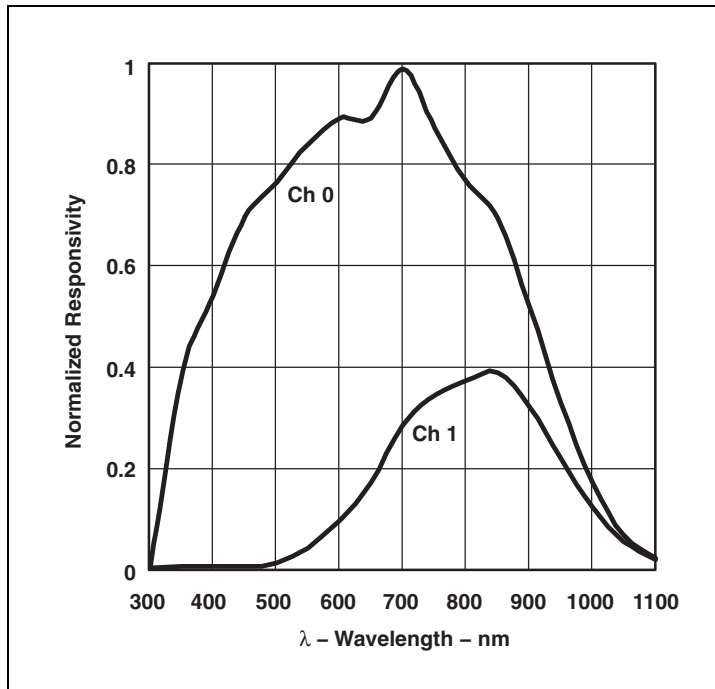
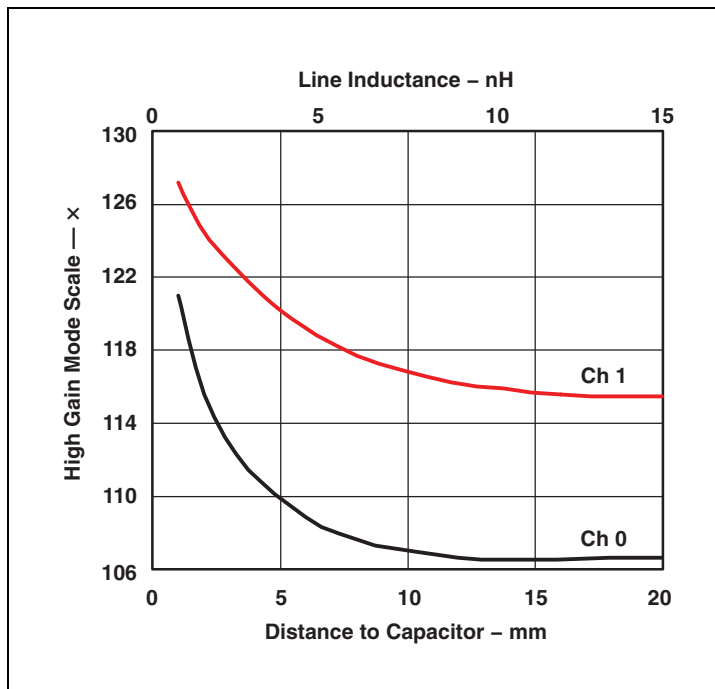
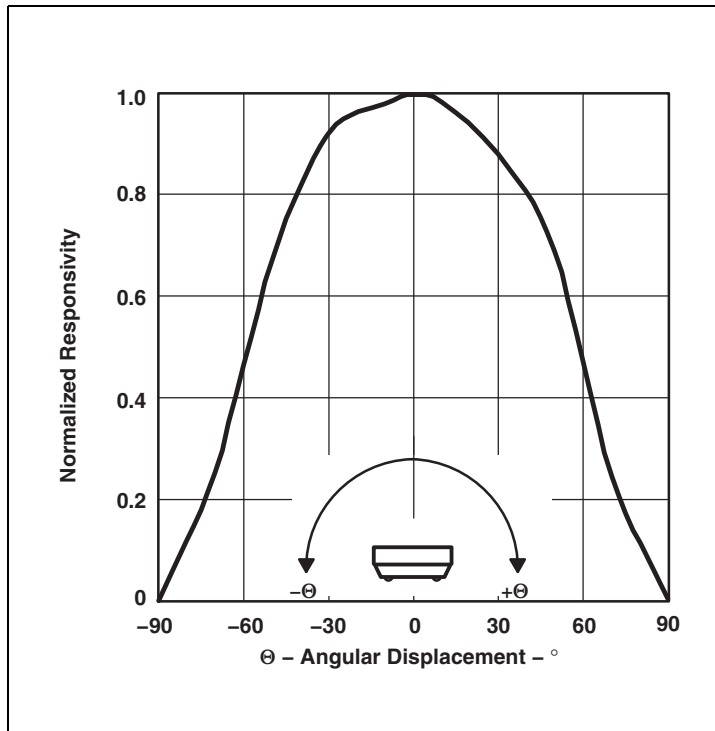

Figure 13:  
111 Gain Scale vs. Line Inductance



**Figure 14:**  
**Normalized Responsivity vs. Angular Displacement**



## Principles Of Operation

### Analog-to-Digital Converter

The TSL258x contains two integrating analog-to-digital converters (ADC) that integrate the currents from the channel 0 and channel 1 photodiodes. Integration of both channels occurs simultaneously, and upon completion of the conversion cycle the conversion result is transferred to the channel 0 and channel 1 data registers, respectively. The transfers are double buffered to ensure that invalid data is not read during the transfer. After the transfer, the device automatically begins the next integration cycle.

### Digital Interface

Interface and control of the TSL258x is accomplished through a two-wire serial interface to a set of registers that provide access to device control functions and output data. The serial interface is compatible with I<sup>2</sup>C bus Fast-Mode. The TSL258x offers three slave addresses that are selectable via an external pin (ADDR SEL). The slave address options are shown in [Figure 15](#).

**Figure 15:**  
Slave Address Selection

Addr Sel Terminal Level	Slave Address
GND	0101001
Float	0111001
V <sub>DD</sub>	1001001

**Note(s):**



1. A read/write bit should be appended to the slave address by the master device to properly communicate with the TSL258x device.

## I<sup>2</sup>C Protocols

Interface and control are accomplished through an I<sup>2</sup>C serial compatible interface (standard or fast mode) to a set of registers that provide access to device control functions and output data. The devices support the 7-bit I<sup>2</sup>C addressing protocol.

The I<sup>2</sup>C standard provides for three types of bus transaction: read, write, and a combined protocol (Figure 16). During a write operation, the first byte written is a command byte followed by data. In a combined protocol, the first byte written is the command byte followed by reading a series of bytes. If a read command is issued, the register address from the previous command will be used for data access. Likewise, if the MSB of the command is not set, the device will write a series of bytes at the address stored in the last valid command with a register address. The command byte contains either control information or a 5-bit register address. The control commands can also be used to clear interrupts.

The I<sup>2</sup>C bus protocol was developed by Philips (now NXP). For a complete description of the I<sup>2</sup>C protocol, please review the NXP I<sup>2</sup>C design specification at [www.i2c-bus.org/references/](http://www.i2c-bus.org/references/).

A	Acknowledge (0)
N	Not Acknowledged (1)
P	Stop Condition
R	Read (1)
S	Start Condition
S	Repeated Start Condition
W	Write (0)
...	Continuation of protocol
	Master-to-Slave
	Slave-to-Master

**Figure 16:**  
**I<sup>2</sup>C Protocol**

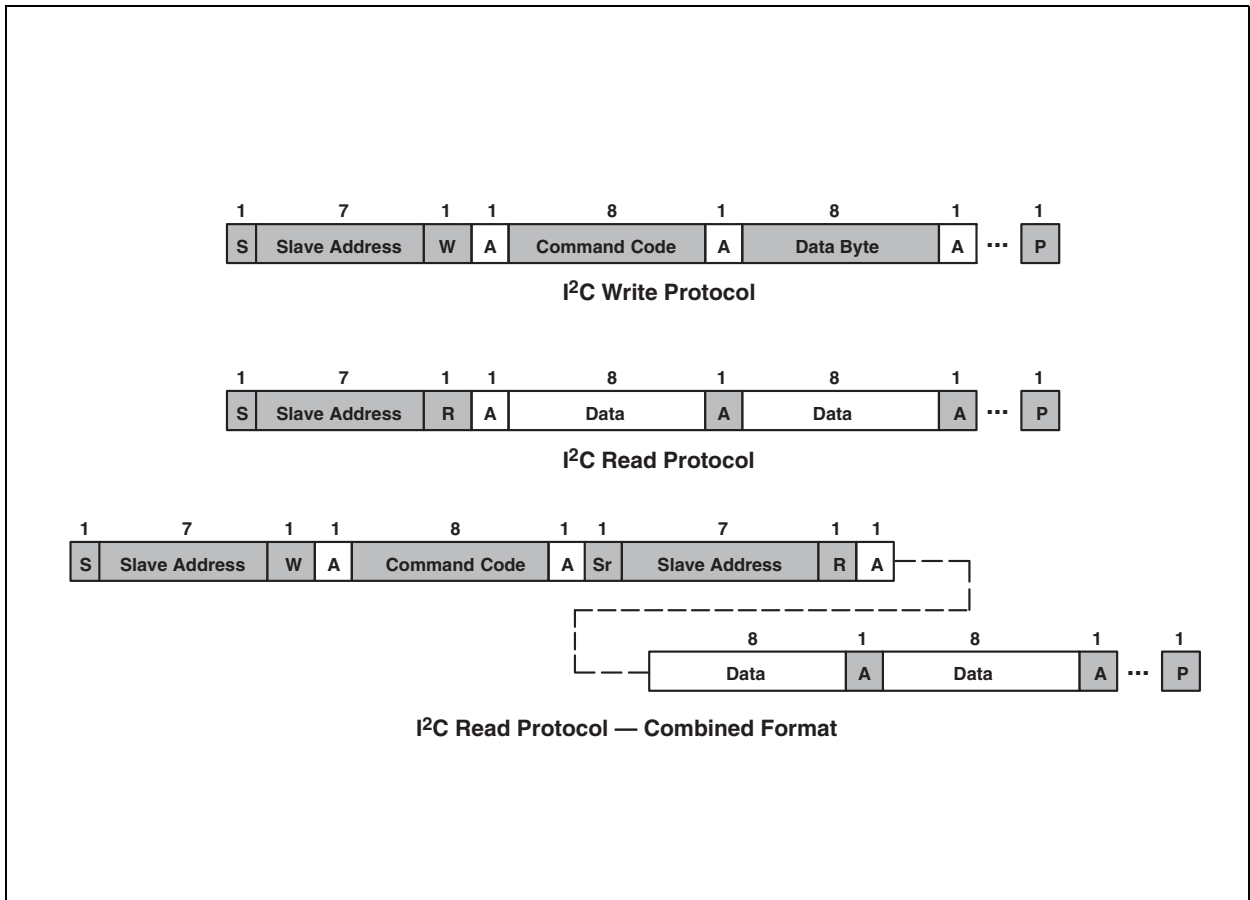

## Register Set

The TSL258x is controlled and monitored by sixteen registers and a command register accessed through the serial interface. These registers provide for a variety of control functions and can be read to determine results of the ADC conversions. The register set is summarized in [Figure 17](#).

**Figure 17:**  
Register Address

Address	Register Name	Register Function	R/W
--	COMMAND	Specifies register address	W
00h	CONTROL	Control of basic functions	R/W
01h	TIMING	Integration time/gain control	
02h	INTERRUPT	Interrupt control	
03h	TLOW	Low byte of low interrupt threshold	
04h	TLHIGH	High byte of low interrupt threshold	
05h	THLOW	Low byte of high interrupt threshold	
06h	THHIGH	High byte of high interrupt threshold	
07h	ANALOG	Analog control register	
12h	ID	Part number / Rev ID	R
14h	DATA0LOW	ADC channel 0 LOW data register	
15h	DATA0HIGH	ADC channel 0 HIGH data register	
16h	DATA1LOW	ADC channel 1 LOW data register	
17h	DATA1HIGH	ADC channel 1 HIGH data register	
18h	TIMERLOW	Manual integration timer LOW register	
19h	TIMERHIGH	Manual integration timer HIGH register	
1Eh	ID2	TSL2581 / TSL2583 ID	R/W

The mechanics of accessing a specific register is given in the I<sup>2</sup>C Protocol section. In general, the COMMAND register is written first to specify the specific control/status register for following read/write operations.



## Command Register

The command register specifies the address of the target register for subsequent read and write operations and contains eight bits as described in Figure 18. The command register defaults to 00h at power on.

**Figure 18:**  
Command Register

7	6	5	4	3	2	1	0
CMD	TRANSACTION			ADDRESS			

Field	Bits	Description	
CMD	7	Select Command Register. Must write as 1 when addressing COMMAND register.	
TRANSACTION	6:5	Selects type of transaction to follow in subsequent data transfers:	
		<b>FIELD VALUE</b>	<b>DESCRIPTION</b>
		00	Repeated byte protocol transaction
		01	Auto-increment protocol transaction
		10	Reserved — Do not use
		11	Special function — See description below
		Transaction type 00 will repeatedly read the same register with each data access. Transaction type 01 will provide an auto-increment function to read successive register bytes.	
ADDRESS	4:0	Address field/special function field. Depending on the transaction type, see above, this field either specifies a special function command or selects the specific control-status-register for following write and read transactions. The field values listed below apply only to special function commands:	
		<b>FIELD VALUE</b>	<b>DESCRIPTION</b>
		00000	Reserved. Write as 0000b.
		00001	Clear any pending interrupt and is a write–once–to–clear bit
		00010	When the Timing Register is set to 00h, a SendByte command with the ADDRESS field set to 0010b will stop a manual integration. The actual length of the integration cycle may be read in the MANUAL INTEGRATION TIMER Register.
		00011	When the Timing Register is set to 00h, a SendByte command with the ADDRESS field set to 0011b will start a manual integration. The actual length of the integration cycle may be read in the MANUAL INTEGRATION TIMER Register.
		x11xx	Reserved. Write as 11xxb.

**Note(s):**

1. An I<sup>2</sup>C block transaction will continue until the Master sends a stop condition. Only the Send Byte Protocol should be used when clearing interrupts

### Control Register (00h)

The CONTROL register primarily used to power the TSL258x device up and down as shown in [Figure 19](#).

**Figure 19:**  
Control Register

7	6	5	4	3	2	1	0
Reserved		ADC_INTR	ADC_VALID	Reserved		ADC_EN	POWER

Field	Bits	Description
Reserved	7:6	Reserved. Write as 0.
ADC_INTR	5	ADC Interrupt. Read only. Indicates that the device is asserting an interrupt.
ADC_VALID	4	ADC Valid. Read only. Indicates that the ADC channel has completed an integration cycle.
Reserved	3:2	Reserved. Write as 0.
ADC_EN	1	ADC Enable. This field enables the two ADC channels to begin integration. Writing a 1 activates the ADC channels, and writing a 0 disables the ADCs.
POWER	0	Power On. Writing a 1 powers on the device, and writing a 0 turns it off.

**Note(s):**

1. ADC\_EN and POWER must be asserted before the ADC changes will operate correctly. After POWER is asserted, a 2-ms delay is required before asserting ADC\_EN.
2. The TSL258x device registers should be configured before ADC\_EN is asserted.

### Timing Register (01h)

The TIMING register controls the internal integration time of the ADC channels in 2.7 ms increments. The TIMING register defaults to 00h at power on.

**Figure 20:**  
Timing Register

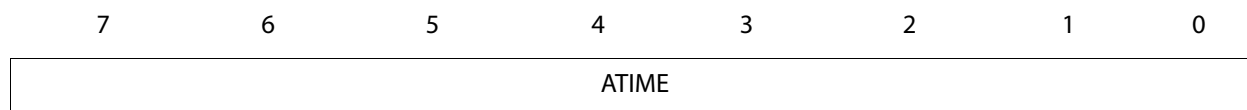

Field	Bits	Description																											
ATIME	7:0	<p>Integration Cycles. Specifies the integration time in 2.7-ms intervals. Time is expressed as a 2's complement number. So, to quickly work out the correct value to write: (1) determine the number of 2.7-ms intervals required, and (2) then take the 2's complement. For example, for a 1 × 2.7-ms interval, 0xFF should be written. For 2 × 2.7-ms intervals, 0xFE should be written. The maximum integration time is 688.5 ms (0000001b).</p> <p>Writing a 0x00 to this register is a special case and indicates manual timing mode. See CONTROL and MANUAL INTEGRATION TIMER Registers for other device options related to manual integration.</p>																											
		<table border="1" style="width: 100%; border-collapse: collapse;"> <thead> <tr> <th style="width: 33%;">INTEG_CYCLES</th> <th style="width: 33%;">TIME</th> <th style="width: 33%;">VALUE</th> </tr> </thead> <tbody> <tr> <td style="text-align: center;">–</td> <td style="text-align: center;">Manual integration</td> <td style="text-align: center;">00000000</td> </tr> <tr> <td style="text-align: center;">1</td> <td style="text-align: center;">2.7 ms</td> <td style="text-align: center;">11111111</td> </tr> <tr> <td style="text-align: center;">2</td> <td style="text-align: center;">5.4 ms</td> <td style="text-align: center;">11111110</td> </tr> <tr> <td style="text-align: center;">19</td> <td style="text-align: center;">51.3 ms</td> <td style="text-align: center;">11101101</td> </tr> <tr> <td style="text-align: center;">37</td> <td style="text-align: center;">99.9 ms</td> <td style="text-align: center;">11011011</td> </tr> <tr> <td style="text-align: center;">74</td> <td style="text-align: center;">199.8 ms</td> <td style="text-align: center;">10110110</td> </tr> <tr> <td style="text-align: center;">148</td> <td style="text-align: center;">399.6 ms</td> <td style="text-align: center;">01101100</td> </tr> <tr> <td style="text-align: center;">255</td> <td style="text-align: center;">688.5 ms</td> <td style="text-align: center;">00000001</td> </tr> </tbody> </table>	INTEG_CYCLES	TIME	VALUE	–	Manual integration	00000000	1	2.7 ms	11111111	2	5.4 ms	11111110	19	51.3 ms	11101101	37	99.9 ms	11011011	74	199.8 ms	10110110	148	399.6 ms	01101100	255	688.5 ms	00000001
		INTEG_CYCLES	TIME	VALUE																									
		–	Manual integration	00000000																									
		1	2.7 ms	11111111																									
		2	5.4 ms	11111110																									
		19	51.3 ms	11101101																									
		37	99.9 ms	11011011																									
		74	199.8 ms	10110110																									
		148	399.6 ms	01101100																									
255	688.5 ms	00000001																											

**Note(s):**

1. The Send Byte protocol cannot be used when ATIME is greater than 127 (for example ATIME[7] = 1) since the upper bit is set aside for write transactions in the COMMAND register.

### Interrupt Register (02h)

The INTERRUPT register controls the extensive interrupt capabilities of the device. The open-drain interrupt pin is active low and requires a pull-up resistor to  $V_{BUS}$  in order to pull high in the inactive state. The Interrupt Register provides control over when a meaningful interrupt will occur. The concept of meaningful change can be defined by the user both in terms of light intensity and time, or persistence of that change in intensity. The value must cross the threshold (as configured in the Threshold Registers 03h through 06h) and persist for some period of time, as outlined in [Figure 23](#).

When a level Interrupt is selected, an interrupt is generated whenever the last conversion results in a value outside of the programmed threshold window. The interrupt is active-low and remains asserted until cleared by writing an 11 in the TRANSACTION field in the COMMAND register.

**Note(s):** Interrupts are based on the value of Channel 0 only.

**Figure 21:**  
Interrupt Control Register

7	6	5	4	3	2	1	0
Resv	INTR_STOP	Resv	INTR	PERSIST			

Field	Bits	Description
Resv	7	Reserved. Write as 0.
INTR_STOP	6	Stop ADC integration on interrupt. When high, ADC integration will stop once an interrupt is asserted. To resume operation (1) de-assert ADC_EN using CONTROL register, (2) clear interrupt using COMMAND register, and (3) re-assert ADC_EN using CONTROL register. <sup>(1)</sup>
Resv	5	Reserved. Write as 0.
INTR	4	INTR Control Select. This field determines mode of interrupt logic according to <a href="#">Figure 22</a> , below.
PERSIST	3:0	Interrupt persistence. Controls rate of interrupts to the host processor as shown in <a href="#">Figure 23</a> , below.

**Note(s):**

1. Use this bit to isolate a particular condition when the sensor is continuously integrating.

**Figure 22:**  
**Interrupt Control Select**

Intr Field Value	Read Value
0	Interrupt output disabled
1	Level Interrupt

**Figure 23:**  
**Interrupt Persistence Select**

Persist Field Value	Interrupt Persist Function
0000	Every ADC cycle generates interrupt
0001	Any value outside of threshold range
0010	2 integration time periods out of range
0011	3 integration time periods out of range
0100	4 integration time periods out of range
0101	5 integration time periods out of range
0110	6 integration time periods out of range
0111	7 integration time periods out of range
1000	8 integration time periods out of range
1001	9 integration time periods out of range
1010	10 integration time periods out of range
1011	11 integration time periods out of range
1100	12 integration time periods out of range
1101	13 integration time periods out of range
1110	14 integration time periods out of range
1111	15 integration time periods out of range

### Interrupt Threshold Register (03h - 06h)

The interrupt threshold registers store the values to be used as the high and low trigger points for the comparison function for interrupt generation. If the value generated by channel 0 crosses below or is equal to the low threshold specified, an interrupt is asserted on the interrupt pin. If the value generated by channel 0 crosses above the high threshold specified, an interrupt is asserted on the interrupt pin. Registers TLOW and TLHIGH provide the low byte and high byte, respectively, of the lower interrupt threshold. Registers THLOW and THHIGH provide the low and high bytes, respectively, of the upper interrupt threshold. The high and low bytes from each set of registers are combined to form a 16-bit threshold value. The interrupt threshold registers default to 00h on power up.

**Figure 24:**  
Interrupt Threshold Register

Register	Address	Bits	Description
TLOW	3h	7:0	ADC channel 0 lower byte of the low threshold
TLHIGH	4h	7:0	ADC channel 0 upper byte of the low threshold
THLOW	5h	7:0	ADC channel 0 lower byte of the high threshold
THHIGH	6h	7:0	ADC channel 0 upper byte of the high threshold

**Note(s):**

1. Since two 8-bit values are combined for a single 16-bit value for each of the high and low interrupt thresholds, the Send Byte protocol should not be used to write to these registers. Any values transferred by the Send Byte protocol with the MSB set would be interpreted as the COMMAND field and stored as an address for subsequent read/write operations and not as the interrupt threshold information as desired. The Write Word protocol should be used to write byte-paired registers. For example, the TLOW and TLHIGH registers (as well as the THLOW and THHIGH registers) can be written together to set the 16-bit ADC value in a single transaction.

### Analog Register (07h)

The ANALOG register provides eight bits of control to the analog block. These bits control the analog gain settings of the device.

**Figure 25:**  
**Analog Register**

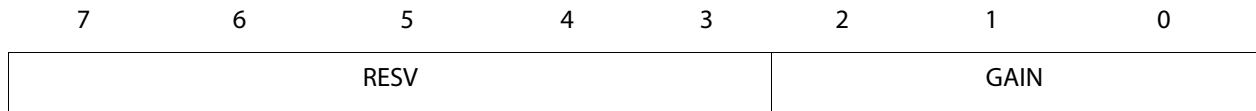

Field	Bits	Description	
Resv	7:3	Reserved. Write as 0.	
Gain	2:0	Gain Control. Sets the analog gain of the device according to the following table.	
		FIELD VALUE	GAIN VALUE
		X00	1x
		X01	8x
		X10	16x
X11	111x		

### ID Register (12h)

The ID register provides the value for both the part number and silicon revision number for that part number. It is a read-only register whose value never changes.

**Figure 26:**  
ID Register

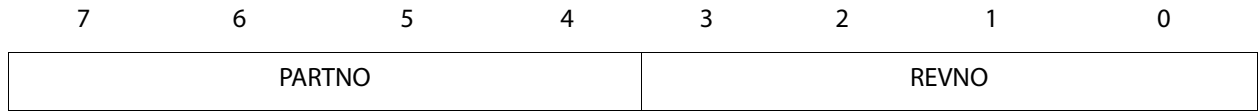

Field	Bits	Description
PARTNO	7:4	Part Number Identification: field value 1001b
REVNO	3:0	Revision number identification



### ADC Channel Data Registers (14h - 17h)

The ADC channel data are expressed as 16-bit values spread across two registers. The ADC channel 0 data registers, DATA0LOW and DATA0HIGH provide the lower and upper bytes, respectively, of the ADC value of channel 0. Registers DATA1LOW and DATA1HIGH provide the lower and upper bytes, respectively, of the ADC value of channel 1. All channel data registers are read-only and default to 00h on power up.

**Figure 27:**  
ADC Channel Data Registers

Register	Address	Bits	Description
DATA0LOW	14h	7:0	ADC channel 0 lower byte
DATA0HIGH	15h	7:0	ADC channel 0 upper byte
DATA1LOW	16h	7:0	ADC channel 1 lower byte
DATA1HIGH	17h	7:0	ADC channel 1 upper byte

The upper byte data registers can only be read following a read to the corresponding lower byte register. When the lower byte register is read, the upper eight bits are strobed into a shadow register, which is read by a subsequent read to the upper byte. The upper register will read the correct value even if additional ADC integration cycles end between the reading of the lower and upper registers.

**Note(s):** The Read Word protocol can be used to read byte-paired registers. For example, the DATA0LOW and DATA0HIGH registers (as well as the DATA1LOW and DATA1HIGH registers) may be read together to obtain the 16-bit ADC value in a single transaction

### Manual Integration Timer Registers (18h - 19h)

The MANUAL INTEGRATION TIMER registers provide the number of cycles in 10.9  $\mu$ s increments that occurred during a manual start/stop integration period. The timer is expressed as a 16-bit value across two registers. See [Control Register \(00h\)](#) and [Timing Register \(01h\)](#) for further instructions in configuring a manual integration. The maximum time that can be derived without an overflow is 714.3 ms.

**Figure 28:**  
Manual Integration Timer Registers

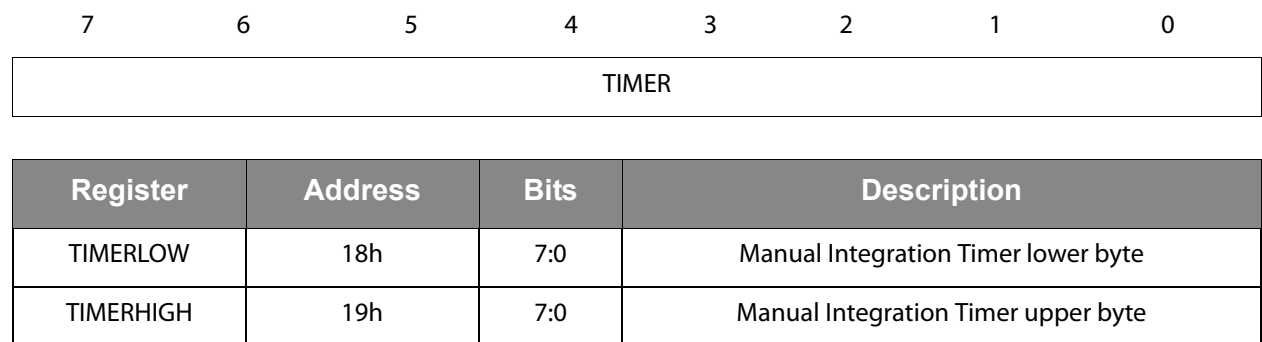

### ID2 Register (1Eh)

In combination with the ID register, the ID2 register provides a means to identify the device as a TSL2581 or a TSL2583. Although this is a W/R register, it is strongly advised that this register not be written to. Any value written to this register could adversely affect the performance of the device.

**Figure 29:**  
ID2 Register

	7	6	5	4	3	2	1	0
	Reserved		ID		Reserved			

Field	Bit	Description
Reserved	7:6	Reserved.
ID	5:4	ID. 00b = TSL2581, 11b = TSL2583
Reserved	3:0	Reserved.

**Application Information:  
Software**

**Basic Operation**

After applying  $V_{DD}$ , the device will initially be in the power-down state. To operate the device, issue a command to access the CONTROL register followed by the data value 01h to the CONTROL register to power up the device. The TIMING register should be configured for the preferred integration period, and then the ADC\_EN should be set to 1 to enable both ADC channels.

For example code that illustrates initializing and reading the device, see DN42: *TSL258x: Accurate ADC Readings after Enable*.

**Figure 30:  
State Diagram**

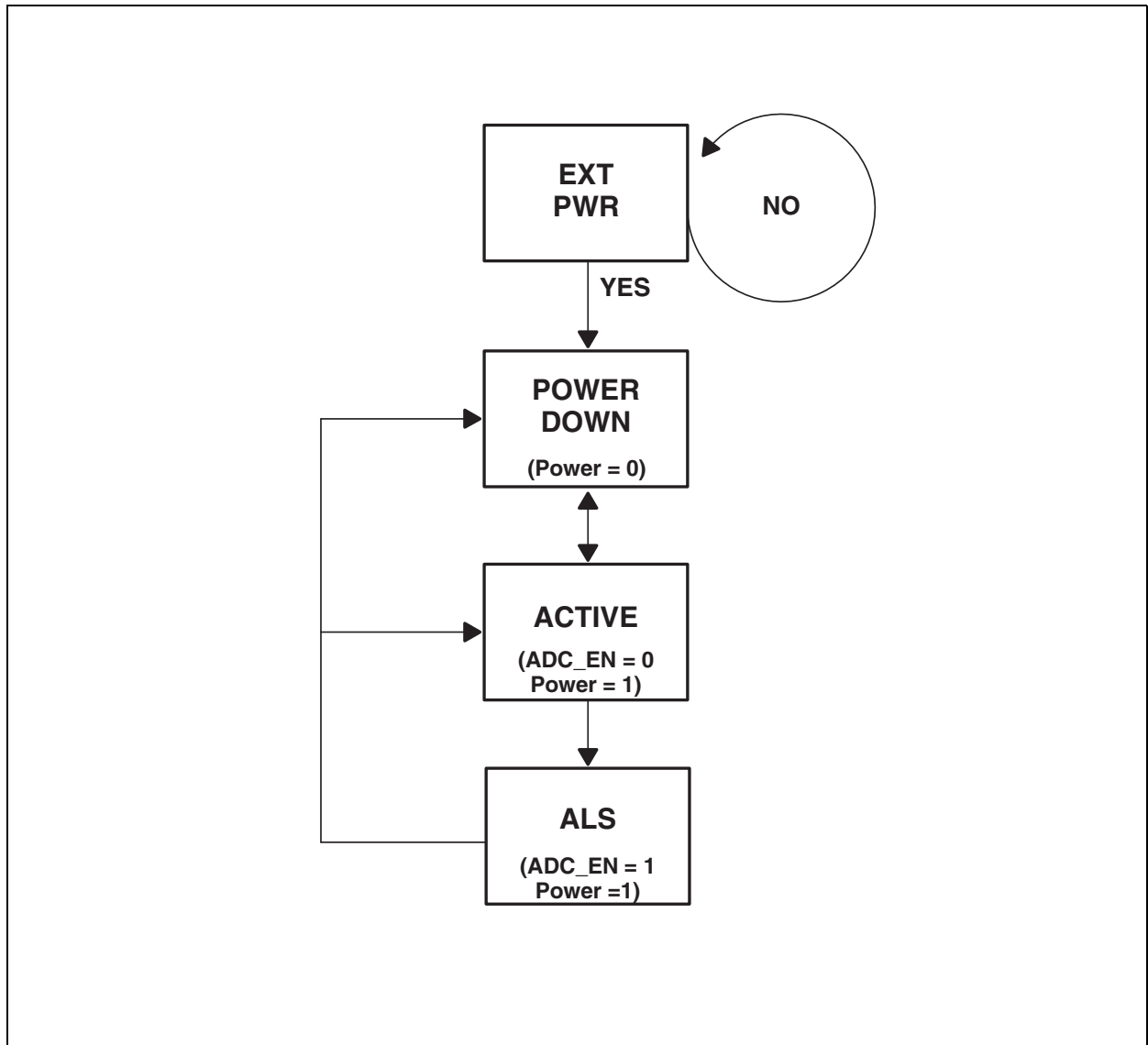

## Interrupts

The interrupt feature of the TSL258x device simplifies and improves system efficiency by eliminating the need to poll the sensor for a light intensity value. Interrupt mode is determined by the INTR field in the INTERRUPT CONTROL Register. The interrupt feature may be disabled by writing a field value of 00h to the Interrupt Control Register (02h) so that polling can be performed.

The versatility of the interrupt feature provides many options for interrupt configuration and usage. The primary purpose of the interrupt function is to signal a meaningful change in light intensity. However, it can also be used as an end-of-conversion signal. The concept of a meaningful change can be defined by the user both in terms of light intensity and time, or persistence, of that change in intensity. The TSL258x device implements two 16-bit-wide interrupt threshold registers that allow the user to define thresholds above and below a desired light level. An interrupt will then be generated when the value of a conversion exceeds either of these limits. For simplicity of programming, the threshold comparison is accomplished only with Channel 0. This simplifies calculation of thresholds that are based, for example, on a percent of the current light level. It is adequate to use only one channel when calculating light intensity differences because, for a given light source, the channel 0 and channel 1 values are linearly proportional to each other and thus both values scale linearly with light intensity.

To further control when an interrupt occurs, the TSL258x device provides an interrupt persistence feature. This feature allows the user to specify a number of conversion cycles for which a light intensity exceeding either interrupt threshold must persist before actually generating an interrupt. This can be used to prevent transient changes in light intensity from generating an unwanted interrupt. With a value of 1, an interrupt occurs immediately whenever either threshold is exceeded. With values of N, where N can range from 2 to 15, N consecutive conversions must result in values outside the interrupt window for an interrupt to be generated. For example, if N is equal to 10 and the integration time is 402 ms, then an interrupt will not be generated unless the light level persists for more than 4 seconds outside the threshold.

The interrupt line goes active low and remains low until the interrupt is cleared by selecting the Special Function in the COMMAND register and writing a 0 to the Interrupt Clear field value.

To configure the interrupt as an end-of-conversion signal so that every ADC integration cycle generates an interrupt, the interrupt PERSIST field in the Interrupt Control Register (02h) is set to 0000b. An interrupt will be generated upon completion of each conversion. The interrupt threshold registers are ignored.

## System Considerations

There are three system design considerations to take into account when using this device:

- The initial Channel 0 and Channel 1 ADC values (14h~17h) after ADC\_EN is asserted should be discarded because the first ADC values are affected by transients associated with the power up of the analog circuitry.
- It is recommended that the ADC\_EN be disabled before changing the analog gain (GAIN) in the Analog register (07h) because the change will affect the integration in progress, yielding an indeterminate result.
- The integration time (ITIME) in the Timing register (01h) can be changed at any time; however, the change will take effect only upon completion of the current ALS cycle.

Regarding the first design consideration, there are several ways that the initial ADC values can be discarded. One option is to use the interrupt persistence (PERSIST) in the Interrupt Control register (02h) equal to 2 (0010b), such that an interrupt is generated after the second ADC cycle when the values are valid. To ensure an interrupt, the interrupt high and low threshold registers (03h~06h) can both be set to 0, which is the default value. Once the interrupt occurs, the interrupt thresholds and PERSIST can be modified as desired.

To ensure the shortest time in the initial ADC cycle, another option is to set ITIME to the minimum, assert ADC\_EN, and then change ITIME to the preferred integration time. Clear the first interrupt produced by the minimum integration time cycle so subsequent interrupts are the result of the modified integration time.

For example code that satisfies the system considerations listed above, see DN42: *TSL258x: Accurate ADC Readings after Enable*.

## Calculating Lux

The TSL258x is intended for use in ambient light detection applications such as display backlight control, where adjustments are made to display brightness or contrast based on the brightness of the ambient light, as perceived by the human eye. Conventional silicon detectors respond strongly to infrared light, which the human eye does not see. This can lead to significant error when the infrared content of the ambient light is high, such as with incandescent lighting, due to the difference between the silicon detector response and the brightness perceived by the human eye.

This problem is overcome in the TSL258x through the use of two photodiodes. One of the photodiodes (channel 0) is sensitive to both visible and infrared light, while the second photodiode (channel 1) is sensitive primarily to infrared light. An integrating ADC converts the photodiode currents to digital outputs. Channel 1 digital output is used to compensate for the effect of the infrared component of light on the channel 0 digital output. The ADC digital outputs from the two channels are used in a formula to obtain a value that approximates the human eye response in the commonly used Illuminance unit of Lux:

### **Chipscale Package**

For  $CH1/CH0 = 0.00$  to  $0.25$  Lux =  $0.105 \times CH0 - 0.208 \times CH1$

For  $CH1/CH0 = 0.25$  to  $0.38$  Lux =  $0.1088 \times CH0 - 0.2231 \times CH1$

For  $CH1/CH0 = 0.38$  to  $0.45$  Lux =  $0.0729 \times CH0 - 0.1286 \times CH1$

For  $CH1/CH0 = 0.45$  to  $0.60$  Lux =  $0.060 \times CH0 - 0.10 \times CH1$

For  $CH1/CH0 > 0.60$  Lux/ $CH0 = 0$

### **FN Package**

For  $CH1/CH0 = 0.00$  to  $0.30$  Lux =  $0.130 \times CH0 - 0.240 \times CH1$

For  $CH1/CH0 = 0.30$  to  $0.38$  Lux =  $0.1649 \times CH0 - 0.3562 \times CH1$

For  $CH1/CH0 = 0.38$  to  $0.45$  Lux =  $0.0974 \times CH0 - 0.1786 \times CH1$

For  $CH1/CH0 = 0.45$  to  $0.54$  Lux =  $0.062 \times CH0 - 0.100 \times CH1$

For  $CH1/CH0 > 0.54$  Lux/ $CH0 = 0$

The formulas shown above were obtained by optical testing with fluorescent and incandescent light sources, and apply only to open-air applications. Optical apertures (e.g. light pipes) will affect the incident light on the device.

## Simplified Lux Calculation

Below is the argument and return value including source code for calculating lux with the TSL2583FN. The source code is intended for embedded and/or microcontroller applications. All floating point arithmetic operations have been eliminated since embedded controllers and microcontrollers generally do not support these types of operations. Because floating point has been removed, scaling must be performed prior to calculating illuminance if the integration time is not 400 msec and/or if the gain is not 1X as denoted in the source code on the following pages.

```

//*****
//
// Copyright ams AG.
//
// THIS CODE AND INFORMATION IS PROVIDED "AS IS" WITHOUT WARRANTY OF ANY
// KIND, EITHER EXPRESSED OR IMPLIED, INCLUDING BUT NOT LIMITED TO THE
// IMPLIED WARRANTIES OF MERCHANTABILITY AND/OR FITNESS FOR A PARTICULAR
// PURPOSE.
//
// Module Name:
// lux.cpp
//
//*****

#define LUX_SCALE 16 // scale by 2^16
#define RATIO_SCALE 9 // scale ratio by 2^9

//-----
// Integration time scaling factors
//-----

#define CH_SCALE 16 // scale channel values by 2^16
#define NOM_INTEG_CYCLE 148 // Nominal 400 ms integration. See Timing Register
//-----
// Gain scaling factors
//-----
#define CH0GAIN128X 107 // 128X gain scalar for Ch0
#define CH1GAIN128X 115 // 128X gain scalar for Ch1
//-----
// FN Package coefficients
//-----
// For Ch1/Ch0=0.00 to 0.30:
//Lux=0.130*Ch0-0.240*Ch1

// For Ch1/Ch0=0.30 to 0.38:
// Lux=0.1649*Ch0-0.3562*Ch1

//
// For Ch1/Ch0=0.38 to 0.45:

```



```
// Lux=0.0974*Ch0-0.1786*Ch1
//
// For Ch1/Ch0=0.45 to 0.54:
// Lux=0.062*Ch0-0.10*Ch1
//
// For Ch1/Ch0>0.54:
// Lux/Ch0=0
//
//-----
#define K1C 0x009A // 0.30 * 2^RATIO_SCALE
#define B1C 0x2148 // 0.130 * 2^LUX_SCALE
#define M1C 0x3d71 // 0.240 * 2^LUX_SCALE

#define K2C 0x00c3 // 0.38 * 2^RATIO_SCALE
#define B2C 0x2a37 // 0.1649 * 2^LUX_SCALE
#define M2C 0x5b30 // 0.3562 * 2^LUX_SCALE

#define K3C 0x00e6 // 0.45 * 2^RATIO_SCALE
#define B3C 0x18ef // 0.0974 * 2^LUX_SCALE
#define M3C 0x2db9 // 0.1786 * 2^LUX_SCALE

#define K4C 0x0114 // 0.54 * 2^RATIO_SCALE
#define B4C 0x0fdf // 0.062 * 2^LUX_SCALE
#define M4C 0x199a // 0.10 * 2^LUX_SCALE

#define K5C 0x0114 // 0.54 * 2^RATIO_SCALE
#define B5C 0x0000 // 0.00000 * 2^LUX_SCALE
#define M5C 0x0000 // 0.00000 * 2^LUX_SCALE
```

```

// lux equation approximation without floating point calculations
//
// Routine: unsigned int CalculateLux(unsigned int ch0, unsigned int ch1, int iType)
//
// Description: Calculate the approximate illuminance (lux) given the raw
// channel values of the TSL2583. The equation is implemented
// as a piece-wise linear approximation.
//
// Arguments: unsigned int iGain - gain, where 0:1X, 1:8X, 2:16X, 3:128X
// unsigned int tIntCycles - INTEG_CYCLES defined in Timing Register
// unsigned int ch0 - raw channel value from channel 0 of TSL2583
// unsigned int ch1 - raw channel value from channel 1 of TSL2583
// unsigned int iType - package type (1:CS)
//
// Return: unsigned int - the approximate illuminance (lux)
//
unsigned int CalculateLux(unsigned int iGain, unsigned int tIntCycles, unsigned int ch0,
unsigned int ch1, int iType)
{
    //-----
    // first, scale the channel values depending on the gain and integration time
    // 1X, 400ms is nominal setting

    unsigned long chScale0;
    unsigned long chScale1;
    unsigned long channel1;
    unsigned long channel0;

    // No scaling if nominal integration (148 cycles or 400 ms) is used
    if (tIntCycles == NOM_INTEG_CYCLE)
        chScale0 = (1 << CH_SCALE);
    else
        chScale0 = (NOM_INTEG_CYCLE << CH_SCALE) / tIntCycles;

    switch (iGain)
    {
        case 0: // 1x gain
            chScale1 = chScale0; // No scale. Nominal setting
            break;
        case 1: // 8x gain
            chScale0 = chScale0 >> 3; // Scale/multiply value by 1/8
            chScale1 = chScale0;
            break;
        case 2: // 16x gain
            chScale0 = chScale0 >> 4; // Scale/multiply value by 1/16
            chScale1 = chScale0;
            break;
        case 3: // 128x gain
            chScale1 = chScale0 / CH1GAIN128X; //Ch1 gain correction factor applied
    }
}

```

```

        chScale0 = chScale0 / CH0GAIN128X;           //Ch0 gain correction factor applied
        break;
    }
    // scale the channel values
    channel0 = (ch0 * chScale0) >> CH_SCALE;
    channel1 = (ch1 * chScale1) >> CH_SCALE;
    //-----
    // find the ratio of the channel values (Channel1/Channel0)
    // protect against divide by zero
    unsigned long ratio1 = 0;
    if (channel0 != 0) ratio1 = (channel1 << (RATIO_SCALE+1)) / channel0;
    // round the ratio value
    unsigned long ratio = (ratio1 + 1) >> 1;

    // is ratio <= eachBreak?
    unsigned int b, m;
    switch (iType)
    {
        case 1: // CS package
            if ((ratio >= 0) && (ratio <= K1C))
                {b=B1C; m=M1C;}
            else if (ratio <= K2C)
                {b=B2C; m=M2C;}
            else if (ratio <= K3C)
                {b=B3C; m=M3C;}
            else if (ratio <= K4C)
                {b=B4C; m=M4C;}
            else if (ratio > K5C)
                {b=B5C; m=M5C;}
            break;
    }

    unsigned long temp;
    unsigned long lux;
    temp = ((channel0 * b) - (channel1 * m));

    // round lsb (2^(LUX_SCALE-1))
    temp += (1 << (LUX_SCALE-1));
    // strip off fractional portion
    lux = temp >> LUX_SCALE;

    return(lux);
}

```

## Application Information: Hardware

### Power Supply Decoupling and Application Hardware Circuit

The power supply lines must be decoupled with a  $0.1\mu\text{F}$  capacitor placed as close to the device package as possible (Figure 31). The bypass capacitor should have low effective series resistance (ESR) and low effective series inductance (ESL), such as the common ceramic types, which provide a low impedance path to ground at high frequencies to handle transient currents caused by internal logic switching.

Figure 13 shows how the  $111\times$  gain is impacted by the line inductance between the  $V_{\text{DD}}$  pin and the decoupling capacitor.

Figure 31:  
Bus Pull-Up Resistors

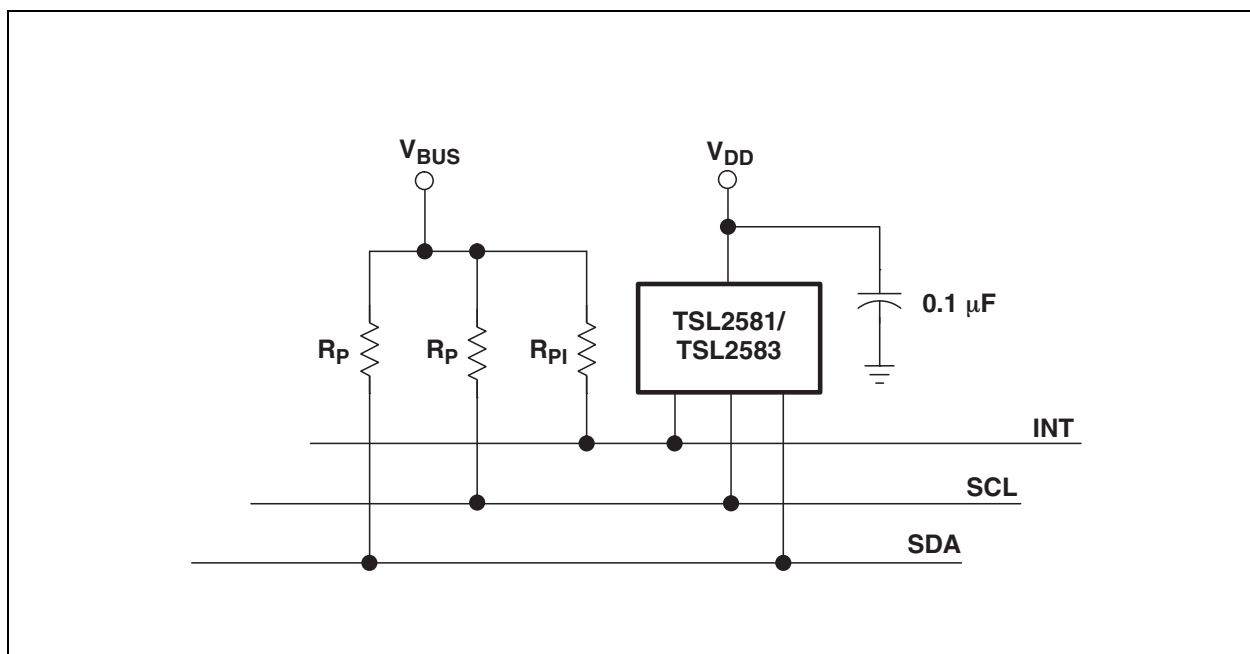

Pull-up resistors ( $R_P$ ) maintain the SCL and SDA lines at a high level when the bus is free and ensure the signals are pulled up from a low to a high level within the required rise time. The I<sup>2</sup>C bus protocol was developed by Philips (now NXP). The pull-up resistor ( $R_P$ ) value is a function of the I<sup>2</sup>C bus speed, the supply voltage, and the capacitive bus loading. Users should consult the NXP I<sup>2</sup>C design specification ([www.i2c-bus.org/references/](http://www.i2c-bus.org/references/)) for assistance. With a lightly loaded bus running at 400 kbps and  $V_{\text{BUS}} = 3\text{ V}$ ,  $1.5\text{ k}\Omega$  resistors have been found to be viable.

A pull-up resistor ( $R_{PI}$ ) is also required for the interrupt (INT), which functions as a wired-AND signal in a similar fashion to the SCL and SDA lines. A typical impedance value between  $10\text{ k}\Omega$  and  $100\text{ k}\Omega$  can be used.

### PCB Pad Layouts

Suggested PCB pad layout guidelines for the CS chipscale package are shown in [Figure 32](#).

**Figure 32:**  
Suggested CS Package PCB Layout

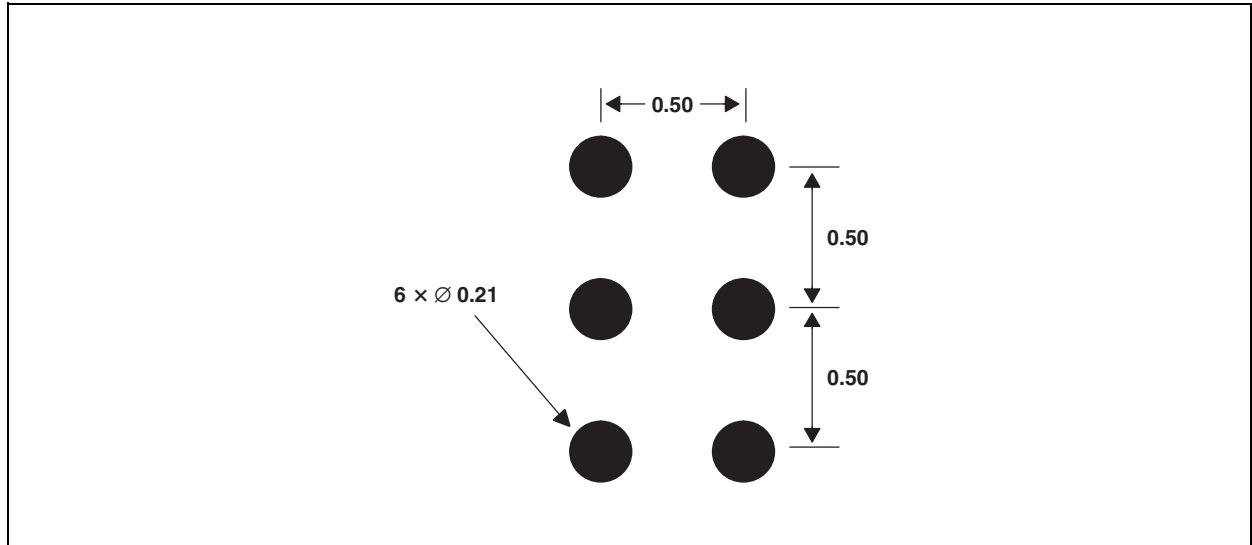

**Note(s):**

1. All linear dimensions are in millimeters.
2. This drawing is subject to change without notice.

Suggested PCB pad layout guidelines for the Dual Flat No-Lead (FN) surface mount package are shown in [Figure 33](#).

**Figure 33:**  
Suggested FN Package PCB Layout

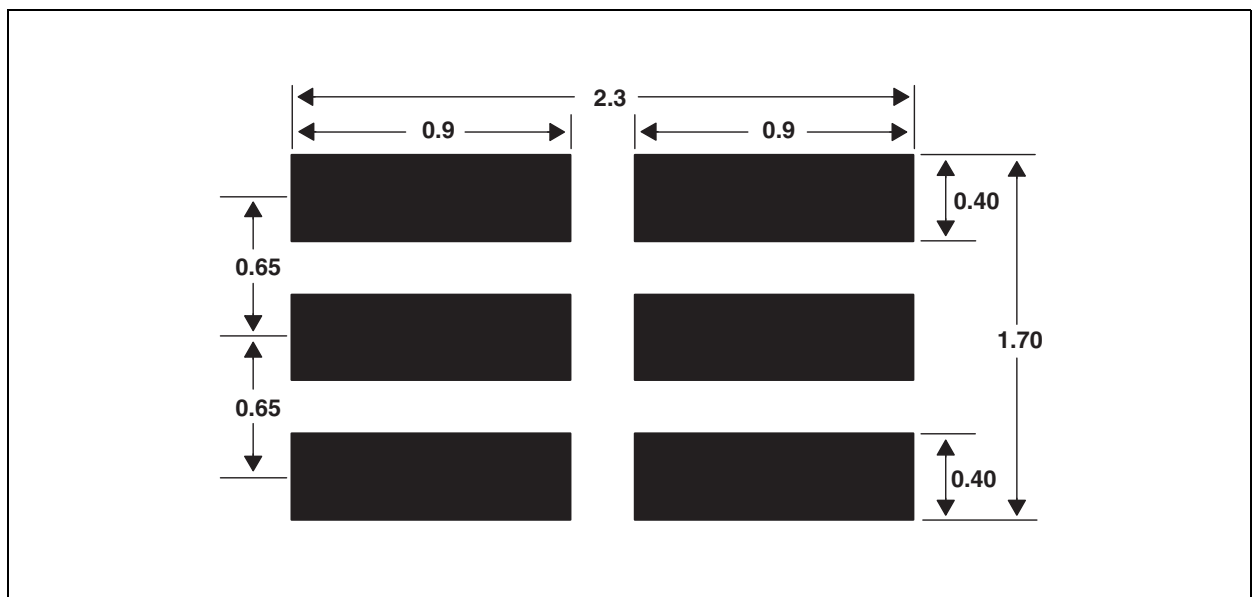

**Note(s):**

1. All linear dimensions are in millimeters.
2. This drawing is subject to change without notice.

### Package Information

Figure 34:  
Package CS — Six-Lead Chipscale Packaging Configuration

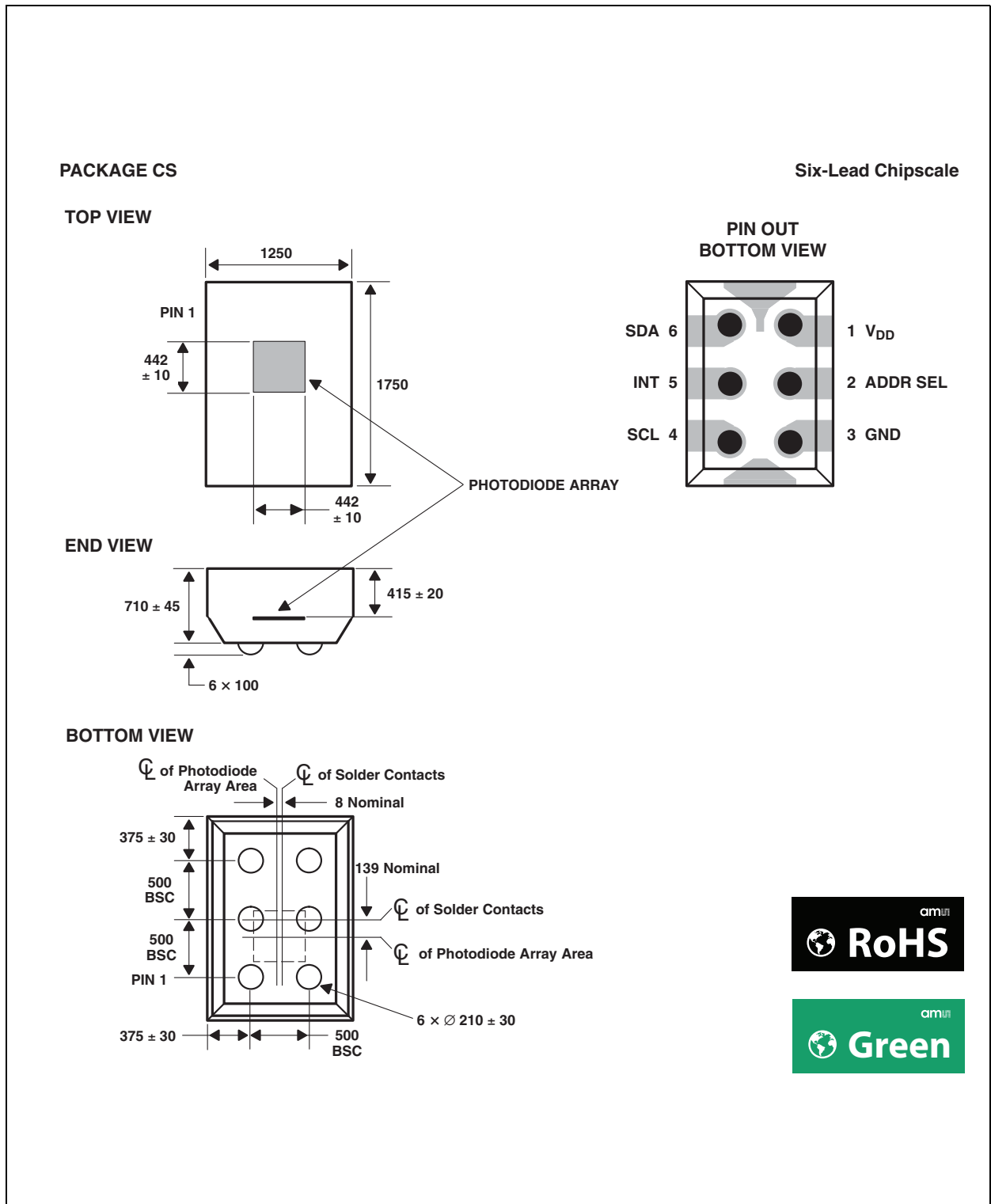

**Note(s):**

1. All linear dimensions are in micrometers. Dimension tolerance is ± 25µm unless otherwise noted.
2. Solder bumps are formed of Sn (96.5%), Ag (3%), and Cu (0.5%).
3. The layer above the photodiode is glass and epoxy with an index of refraction of 1.53.
4. This drawing is subject to change without notice.

**Figure 35:**  
**Package FN — Dual Flat No-Lead Packaging Configuration**

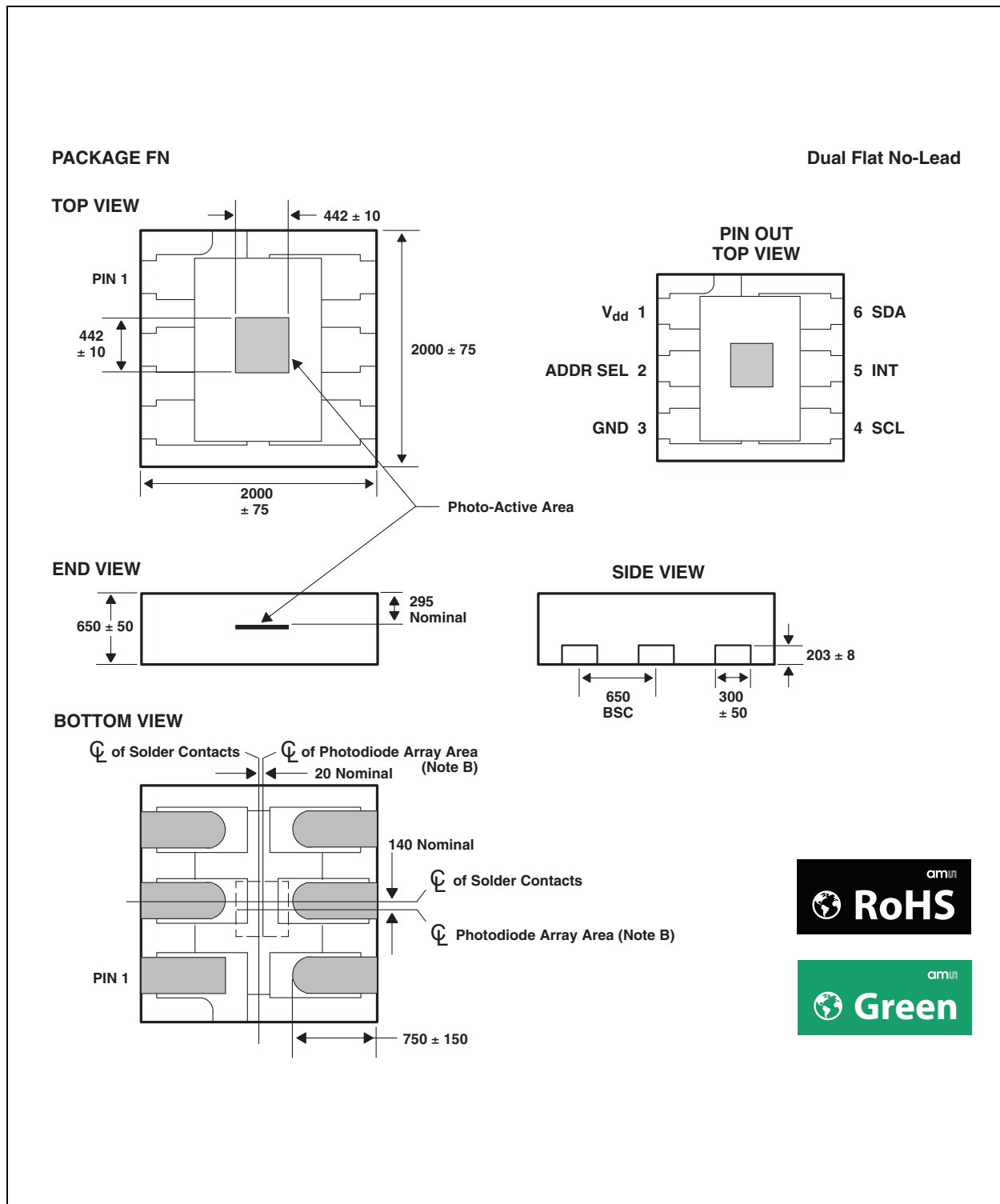

**Note(s):**

1. All linear dimensions are in micrometers. Dimension tolerance is  $\pm 20 \mu\text{m}$  unless otherwise noted.
2. The die is centered within the package within a tolerance of  $\pm 75 \mu\text{m}$ .
3. Package top surface is molded with an electrically nonconductive clear plastic compound having an index of refraction of 1.55.
4. Contact finish is copper alloy A194 with pre-plated NiPdAu lead finish.
5. This package contains no lead (Pb).
6. This drawing is subject to change without notice.

### Carrier Tape & Reel Information

Figure 36:  
Package CS Carrier Tape

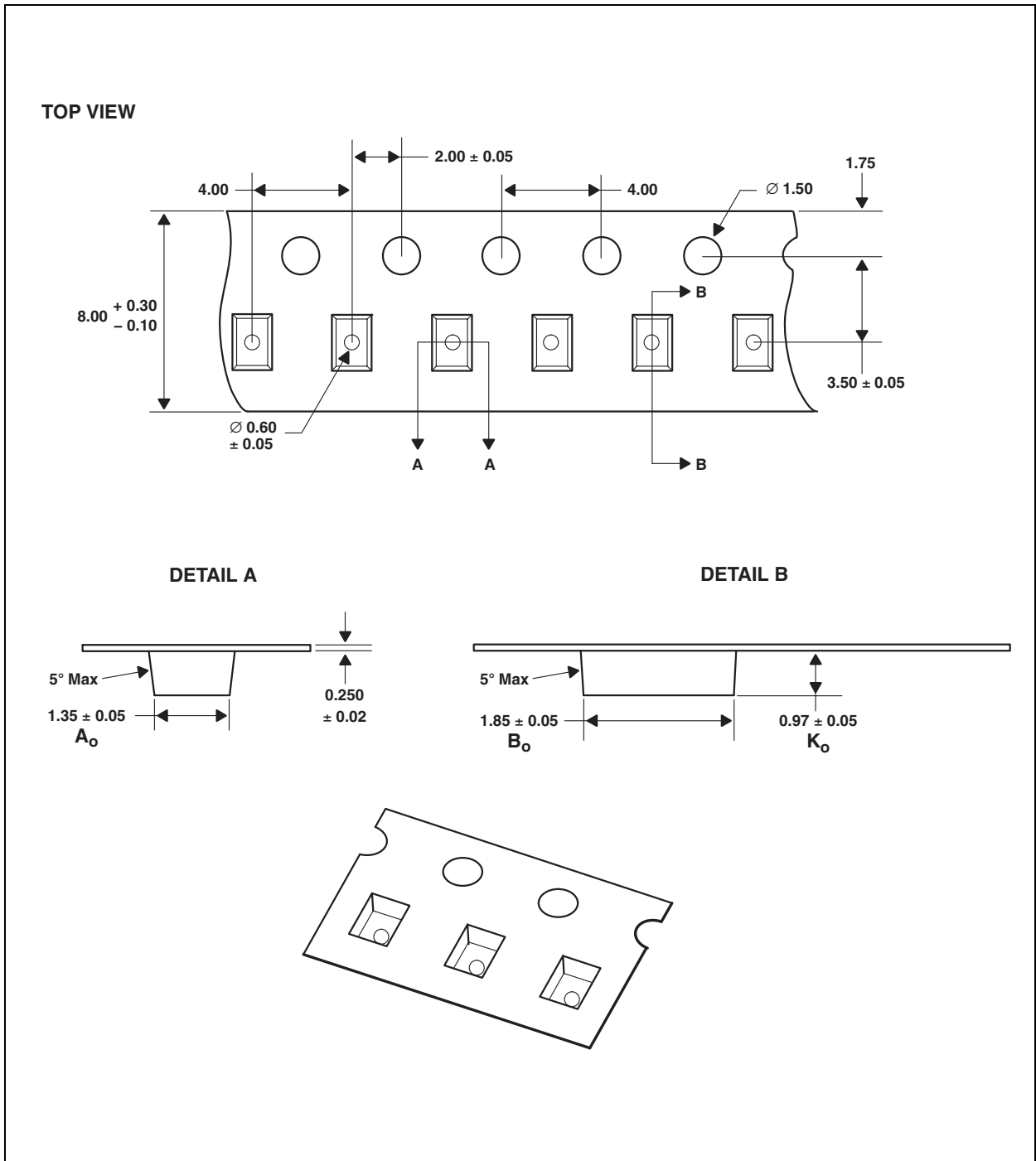

**Note(s):**

1. All linear dimensions are in millimeters. Dimension tolerance is  $\pm 0.10$  mm unless otherwise noted.
2. The dimensions on this drawing are for illustrative purposes only. Dimensions of an actual carrier may vary slightly.
3. Symbols on drawing  $A_o$ ,  $B_o$ , and  $K_o$  are defined in ANSI EIA Standard 481-B 2001.
4. Each reel is 178 millimeters in diameter and contains 3500 parts.
5. ams packaging tape and reel conform to the requirements of EIA Standard 481-B.
6. In accordance with EIA standard, device pin 1 is located next to the sprocket holes in the tape.
7. This drawing is subject to change without notice.



**Figure 37:**  
**Package FN Carrier Tape**

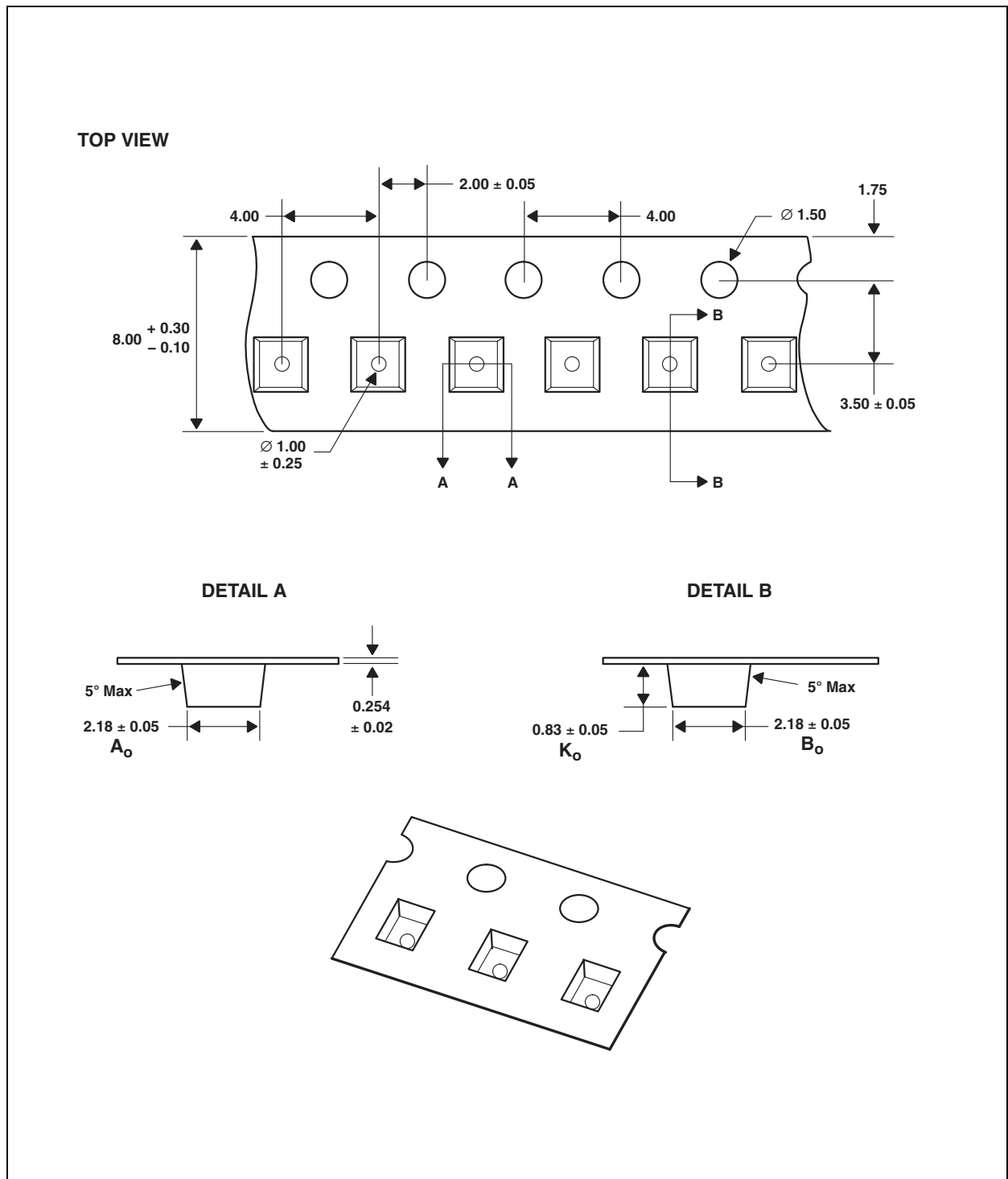

**Note(s):**

1. All linear dimensions are in millimeters. Dimension tolerance is  $\pm 0.10$  mm unless otherwise noted.
2. The dimensions on this drawing are for illustrative purposes only. Dimensions of an actual carrier may vary slightly.
3. Symbols on drawing  $A_0$ ,  $B_0$ , and  $K_0$  are defined in ANSI EIA Standard 481-B 2001.
4. Each reel is 178 millimeters in diameter and contains 3500 parts.
5. **ams** packaging tape and reel conform to the requirements of EIA Standard 481-B.
6. In accordance with EIA standard, device pin 1 is located next to the sprocket holes in the tape.
7. This drawing is subject to change without notice.

### Soldering Information

The package has been tested and have demonstrated an ability to be reflow soldered to a PCB substrate.

The solder reflow profile describes the expected maximum heat exposure of components during the solder reflow process of product on a PCB. Temperature is measured on top of component. The components should be limited to a maximum of three passes through this solder reflow profile.

**Figure 38:**  
Solder Reflow Profile

Parameter	Reference	Device
Average temperature gradient in preheating		2.5°C/s
Soak time	$t_{soak}$	2 to 3 minutes
Time above 217°C ( $T_1$ )	$t_1$	Max 60 s
Time above 230°C ( $T_2$ )	$t_2$	Max 50 s
Time above $T_{peak} - 10^\circ\text{C}$	$t_3$	Max 10 s
Peak temperature in reflow	$T_{peak}$	260°C (-0°C/ 5°C)
Temperature gradient in cooling		Max -5°C/s

**Figure 39:**  
Solder Reflow Profile Graph

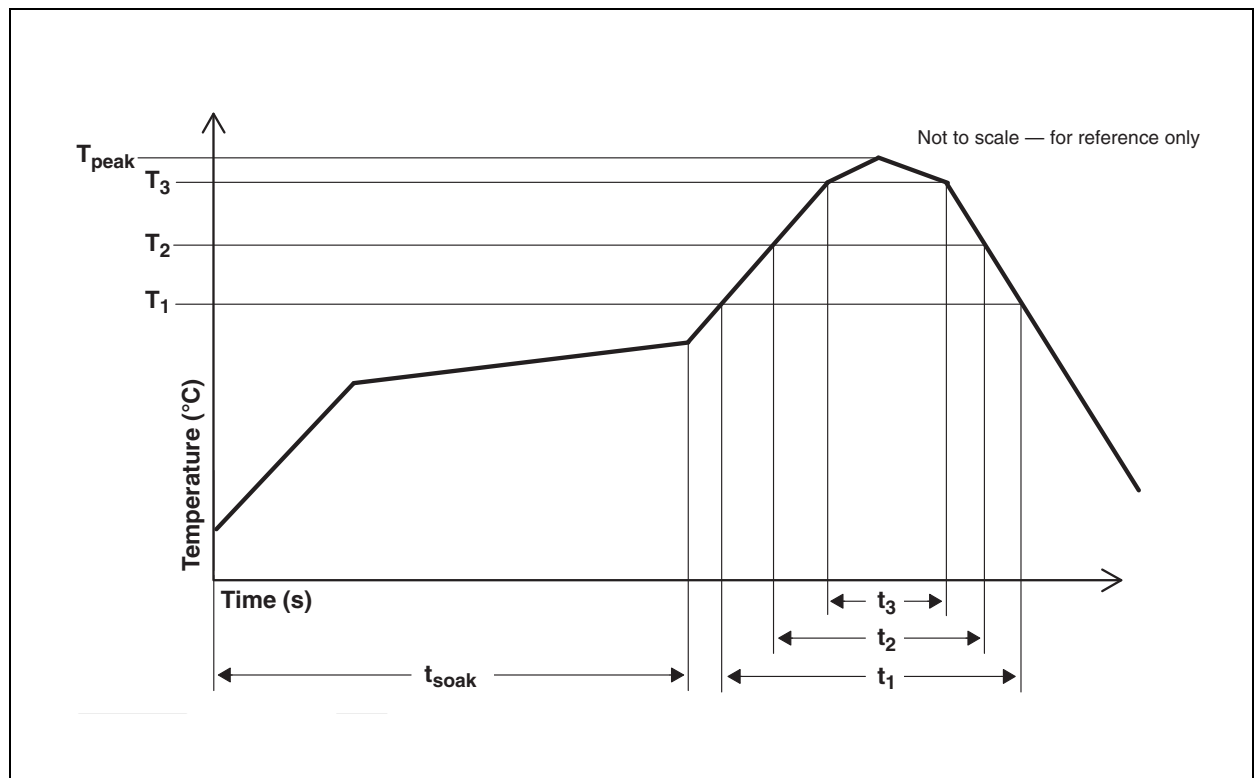

## Storage Information

### **Moisture Sensitivity**

Optical characteristics of the device can be adversely affected during the soldering process by the release and vaporization of moisture that has been previously absorbed into the package molding compound. To ensure the package molding compound contains the smallest amount of absorbed moisture possible, each device is dry-baked prior to being packed for shipping. Devices are packed in a sealed aluminized envelope with silica gel to protect them from ambient moisture during shipping, handling, and storage before use.

### **CS Package**

The CS package has been assigned a moisture sensitivity level of MSL 2 and the devices should be stored under the following conditions:

- Temperature Range: 5°C to 50°C
- Relative Humidity: 60% maximum
- Floor Life: 1 year out of bag at ambient < 30°C / 60% RH

Rebaking will be required if the aluminized envelope has been open for more than 1 year. If rebaking is required, it should be done at 50°C for 12 hours.

### **FN Package**

The FN package has been assigned a moisture sensitivity level of MSL 3 and the devices should be stored under the following conditions:

- Temperature Range: 5°C to 50°C
- Relative Humidity: 60% maximum
- Total Time: 12 months from the date code on the aluminized envelope — if unopened
- Opened Time: 168 hours or fewer

Rebaking will be required if the devices have been stored unopened for more than 12 months or if the aluminized envelope has been open for more than 168 hours. If rebaking is required, it should be done at 50°C for 12 hours.

## Ordering & Contact Information

Figure 40:  
Ordering Information

Ordering Code	Device	Package - Leads	Interface Type
TSL2581CS	TSL2581	CS-6	I <sup>2</sup> C Bus = VDD
TSL2581FN	TSL2581	FN-6	I <sup>2</sup> C Bus = VDD
TSL2583CS	TSL2583 <sup>(1)</sup>	CS-6	I <sup>2</sup> C Bus = 1.8 V
TSL2583FN	TSL2583	FN-6	I <sup>2</sup> C Bus = 1.8 V

**Note(s):**

1. Contact **ams** for availability.

Buy our products or get free samples online at:  
[www.ams.com/ICdirect](http://www.ams.com/ICdirect)

Technical Support is available at:  
[www.ams.com/Technical-Support](http://www.ams.com/Technical-Support)

Provide feedback about this document at:  
[www.ams.com/Document-Feedback](http://www.ams.com/Document-Feedback)

For further information and requests, e-mail us at:  
[ams\\_sales@ams.com](mailto:ams_sales@ams.com)

For sales offices, distributors and representatives, please visit:  
[www.ams.com/contact](http://www.ams.com/contact)

**Headquarters**

ams AG  
Tobelbaderstrasse 30  
8141 Premstaetten  
Austria, Europe

Tel: +43 (0) 3136 500 0

Website: [www.ams.com](http://www.ams.com)

## RoHS Compliant & ams Green Statement

**RoHS:** The term RoHS compliant means that ams AG products fully comply with current RoHS directives. Our semiconductor products do not contain any chemicals for all 6 substance categories, including the requirement that lead not exceed 0.1% by weight in homogeneous materials. Where designed to be soldered at high temperatures, RoHS compliant products are suitable for use in specified lead-free processes.

**ams Green (RoHS compliant and no Sb/Br):** ams Green defines that in addition to RoHS compliance, our products are free of Bromine (Br) and Antimony (Sb) based flame retardants (Br or Sb do not exceed 0.1% by weight in homogeneous material).

**Important Information:** The information provided in this statement represents ams AG knowledge and belief as of the date that it is provided. ams AG bases its knowledge and belief on information provided by third parties, and makes no representation or warranty as to the accuracy of such information. Efforts are underway to better integrate information from third parties. ams AG has taken and continues to take reasonable steps to provide representative and accurate information but may not have conducted destructive testing or chemical analysis on incoming materials and chemicals. ams AG and ams AG suppliers consider certain information to be proprietary, and thus CAS numbers and other limited information may not be available for release.

## Copyrights & Disclaimer

Copyright ams AG, Tobelbader Strasse 30, 8141 Premstaetten, Austria-Europe. Trademarks Registered. All rights reserved. The material herein may not be reproduced, adapted, merged, translated, stored, or used without the prior written consent of the copyright owner.

Devices sold by ams AG are covered by the warranty and patent indemnification provisions appearing in its General Terms of Trade. ams AG makes no warranty, express, statutory, implied, or by description regarding the information set forth herein. ams AG reserves the right to change specifications and prices at any time and without notice. Therefore, prior to designing this product into a system, it is necessary to check with ams AG for current information. This product is intended for use in commercial applications. Applications requiring extended temperature range, unusual environmental requirements, or high reliability applications, such as military, medical life-support or life-sustaining equipment are specifically not recommended without additional processing by ams AG for each application. This product is provided by ams AG "AS IS" and any express or implied warranties, including, but not limited to the implied warranties of merchantability and fitness for a particular purpose are disclaimed.

ams AG shall not be liable to recipient or any third party for any damages, including but not limited to personal injury, property damage, loss of profits, loss of use, interruption of business or indirect, special, incidental or consequential damages, of any kind, in connection with or arising out of the furnishing, performance or use of the technical data herein. No obligation or liability to recipient or any third party shall arise or flow out of ams AG rendering of technical or other services.

## Document Status

Document Status	Product Status	Definition
Product Preview	Pre-Development	Information in this datasheet is based on product ideas in the planning phase of development. All specifications are design goals without any warranty and are subject to change without notice
Preliminary Datasheet	Pre-Production	Information in this datasheet is based on products in the design, validation or qualification phase of development. The performance and parameters shown in this document are preliminary without any warranty and are subject to change without notice
Datasheet	Production	Information in this datasheet is based on products in ramp-up to full production or full production which conform to specifications in accordance with the terms of ams AG standard warranty as given in the General Terms of Trade
Datasheet (discontinued)	Discontinued	Information in this datasheet is based on products which conform to specifications in accordance with the terms of ams AG standard warranty as given in the General Terms of Trade, but these products have been superseded and should not be used for new designs

## Revision Information

Changes from 134A (2012-Jul) to current revision 1-00 (2016-Mar-17)	Page
Content of TAOS datasheet was updated to latest <b>ams</b> design	
Added Benefits & Features table	2

**Note(s):**

1. Page and figure numbers for the previous version may differ from page and figure numbers in the current revision
2. Correction of typographical errors is not explicitly mentioned.



## Content Guide

<b>1</b>	<b>General Description</b>
2	Key Benefits & Features
2	Applications
2	End Products and Market Segments
3	Functional Block Diagram
3	Pin Assignments
4	Detailed Description
<b>6</b>	<b>Absolute Maximum Ratings</b>
9	Parameter Measurement Information
<b>10</b>	<b>Typical Characteristics</b>
<b>12</b>	<b>Principles Of Operation</b>
12	Analog-to-Digital Converter
12	Digital Interface
12	I <sup>2</sup> C Protocols
14	Register Set
15	Command Register
16	Control Register (0x0F)
17	Timing Register (01h)
18	Interrupt Register (02h)
19	Interrupt Threshold Register (03h - 06h)
20	Analog Register (07h)
21	ID Register (12h)
21	ADC Channel Data Registers (14h - 17h)
22	Manual Integration Timer (18h - 19h)
22	ID2 Register (1Eh)
<b>23</b>	<b>Application Information: Software</b>
23	Basic Operation
23	Interrupts
24	System Considerations
25	Calculating Lux
25	Chipscale Package
26	ODFN Package
27	Simplified Lux Calculation
<b>31</b>	<b>Application Information: Hardware</b>
31	Power Supply Decoupling and Application Hardware Circuit
32	PCB Pad Layouts
<b>33</b>	<b>Package Information</b>
<b>35</b>	<b>Carrier Tape And Reel Information</b>
<b>37</b>	<b>Soldering Information</b>
<b>38</b>	<b>Storage Information</b>
38	Moisture Sensitivity
38	CS package
38	FN package

- 39 Ordering & Contact Information**
- 40 RoHS Compliant & ams Green Statement**
- 41 Copyrights & Disclaimer**
- 42 Document Status**
- 43 Revision Information**

# Mouser Electronics

Authorized Distributor

Click to View Pricing, Inventory, Delivery & Lifecycle Information:

[ams OSRAM:](#)

[TSL2581FN](#) [TSL2581CS](#)