



Eval Kit Manual

AS5600L

Adapter Board

AS5600L-WL_EK_AB

Content Guide

1	Introduction	3
1.1	Kit Content	3
2	Board description	4
2.1	Mounting the AS5600L adapter board	5
3	AS5600L adapter board and pinout	6
4	Operation case	7
4.1	I2C Mode	7
5	AS5600L-WL_EK_AB Hardware	8
5.1	AS5600L-WL_EK_AB schematics	8
5.2	AS5600L-WL_EK_AB PCB layout	9
6	Ordering & Contact Information	10
7	Copyrights & Disclaimer	11

1 Introduction

The AS5600L adapter board is a small PCB allowing simple and quick testing or evaluation of the AS5600L magnetic position sensor without the need to build a test fixture or design an own PCB.

1.1 Kit Content

Figure 1: Kit content

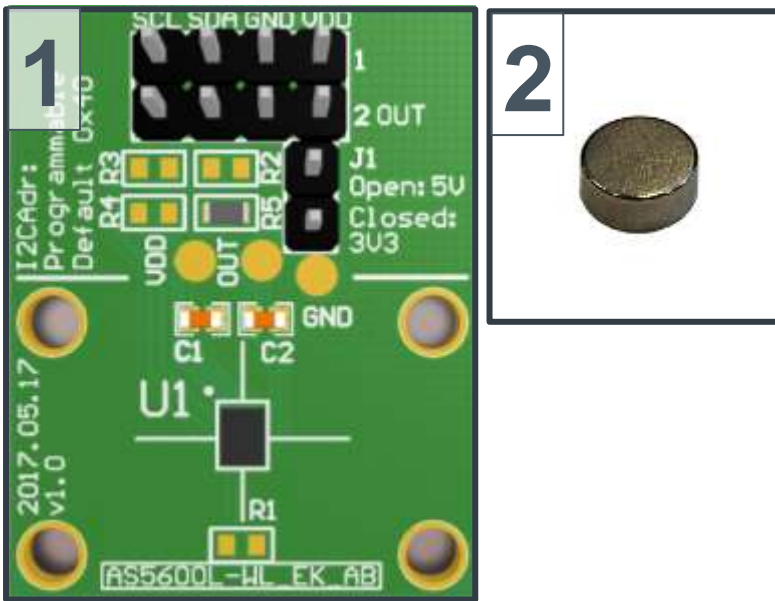

Pos.	Item	Comment
1	AS5600L-WL_EK_AB	Adapter board
2	AS5000-MD6H-2	Diametric Magnet, D6x2.5mm, NdFeB, Bomatec AG

2 Board description

The PCB can either be connected to an external microcontroller or to the USB I&P Box which is available on our webpage. ([USB I&P Box](#))

P1 is populated with a 2x4 90 degree pin header and is required for power supply as well as I2C (SCL, SDA) and PWM(OUT).

The connector J1 allows you to select between 5V or 3.3V operation (Open=5V/Closed=3.3V)

The optional resistor R1 (0R – 0603 package) allows you to enable the 3 wire zero programming feature, where you can set the zero and maximum position without using a μC . (for more details refer to AS5600L datasheet)

R2 and R3 are the optional pull-up resistors for SCL and SDA line.

C1 and C2 are decoupling capacitors.

R4 & R5 are used for the direction polarity. Populate R5 for increasing value in clockwise direction, R4 for counterclockwise.

Figure 2: AS5600L adapter board

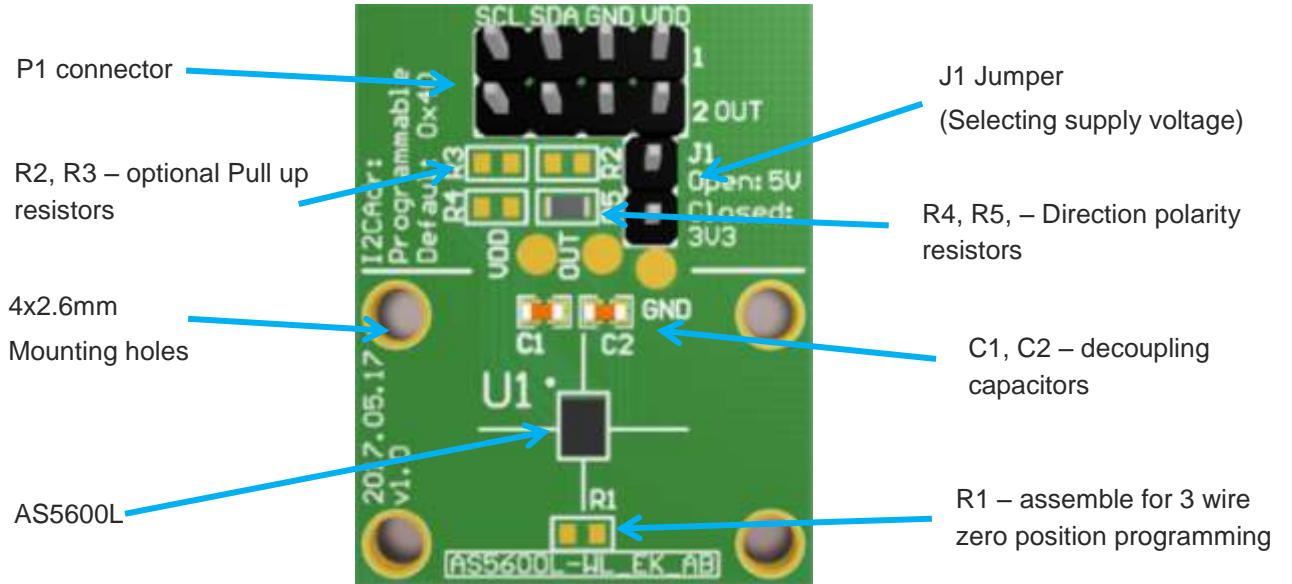

2.1 Mounting the AS5600L adapter board

Figure 3: Mounting and dimensions

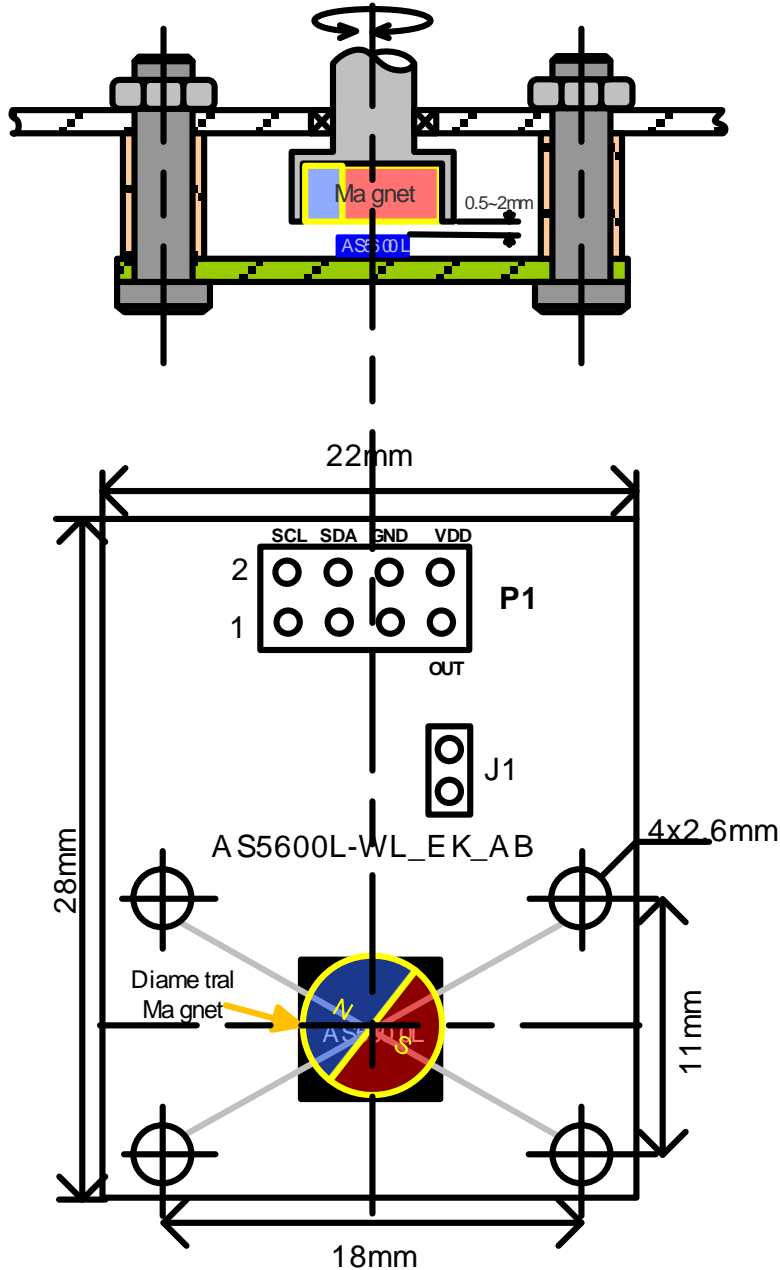

A 6x2.5mm diametric magnet has to be placed over or under the AS5600L sensor, and should be centered on the middle of the sensors hall array (for hall array center please refer to AS5600L Datsheet). The airgap between the magnet surface and the package should be maintained in the range 0.5mm to 3mm. The magnet holder must not be ferromagnetic. Materials as brass, copper, aluminum, stainless steel are the best choices to make this part.

3 AS5600L adapter board and pinout

Figure 4: AS5600L adapter board and sensor pinout (WLCSP)

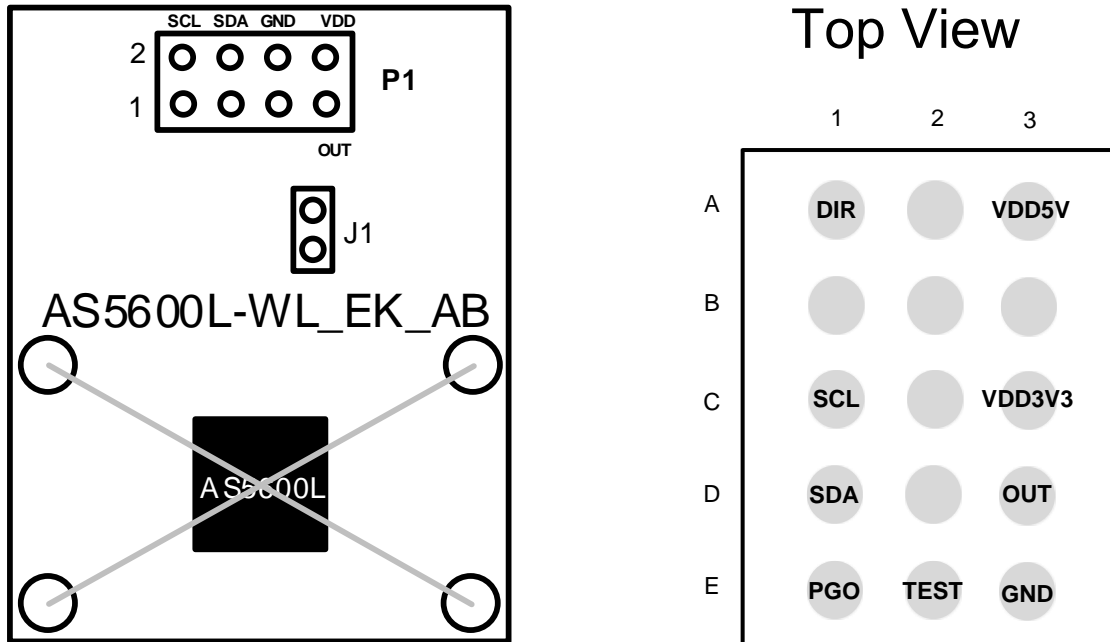

Pin# Board	Pin# AS5600L	Symbol board	Type	Description
P1 - 1	-	nc	-	Not connected
P1 - 2	C1	SCL	Digital input	I ² C Clock line
P1 - 3	-	nc	-	Not connected
P1 - 4	D1	SDA	Digital input/output	I ² C Data line
P1 - 5	-	nc	-	Not connected
P1 - 6	E3	GND	Power supply	Ground
P1 - 7	D3	OUT	Digital output	PWM output
P1 - 8	A3/C3	VDD	Power supply	Positive voltage supply (5V / 3,3V mode)

4 Operation case

4.1 I2C Mode

The AS5600L adapter board can be directly connected to an industry standard I2C port of a microcontroller. The minimum connection requirements for bidirectional communication between the microcontroller and the AS5600L is VDD, GND, SCL and SDA. The slave address is 0x40.

Figure 5: I2C Mode

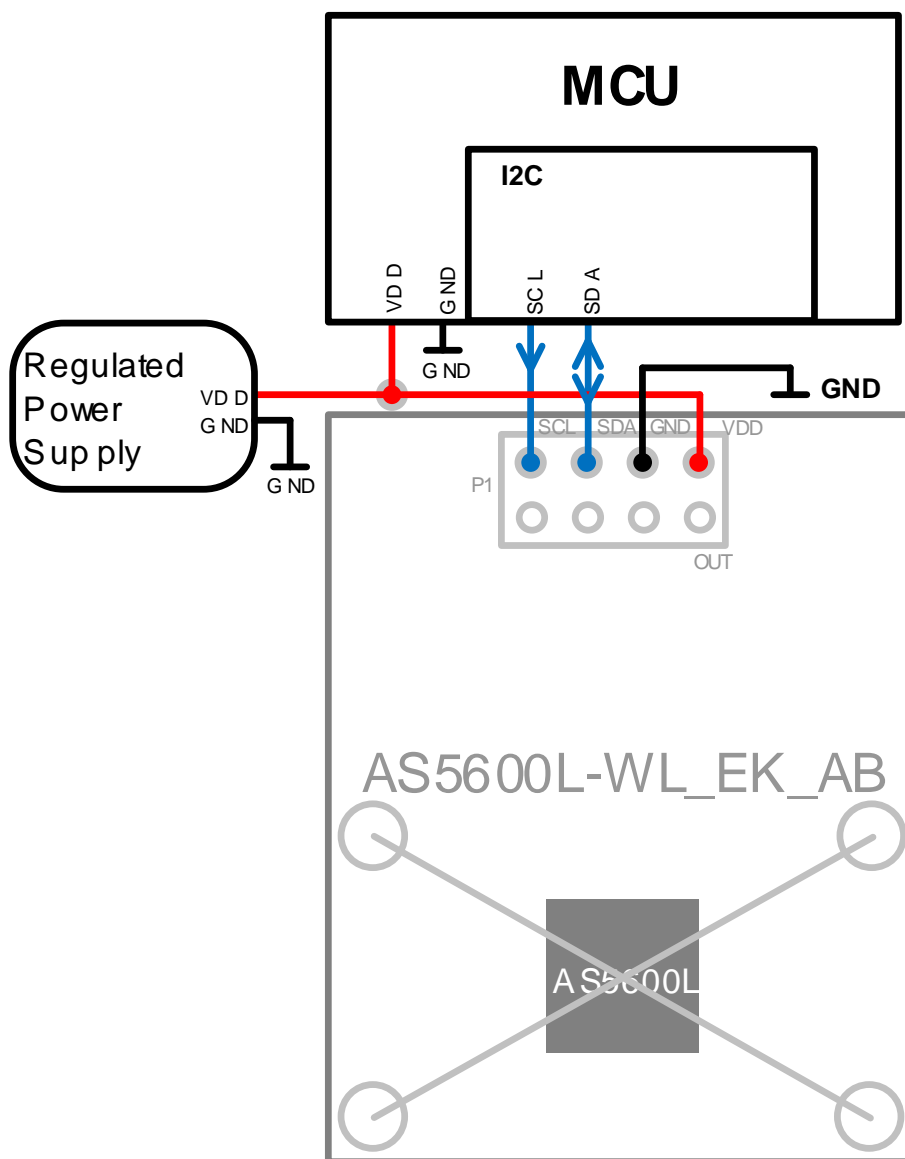

5 AS5600L-WL_EK_AB Hardware

5.1 AS5600L-WL_EK_AB schematics

Figure 6: AS5600L-WL_EK_AB schematics

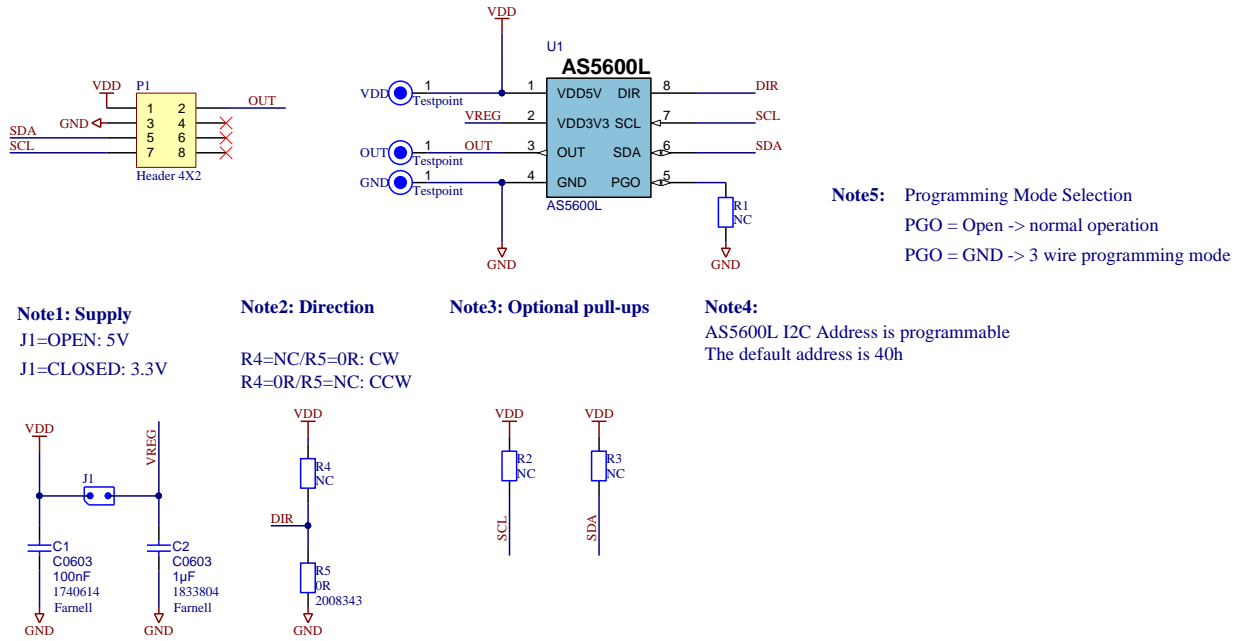

A4

5.2 AS5600L-WL_EK_AB PCB layout

Figure 7: AS5600L-WL_EK_AB PCB layout

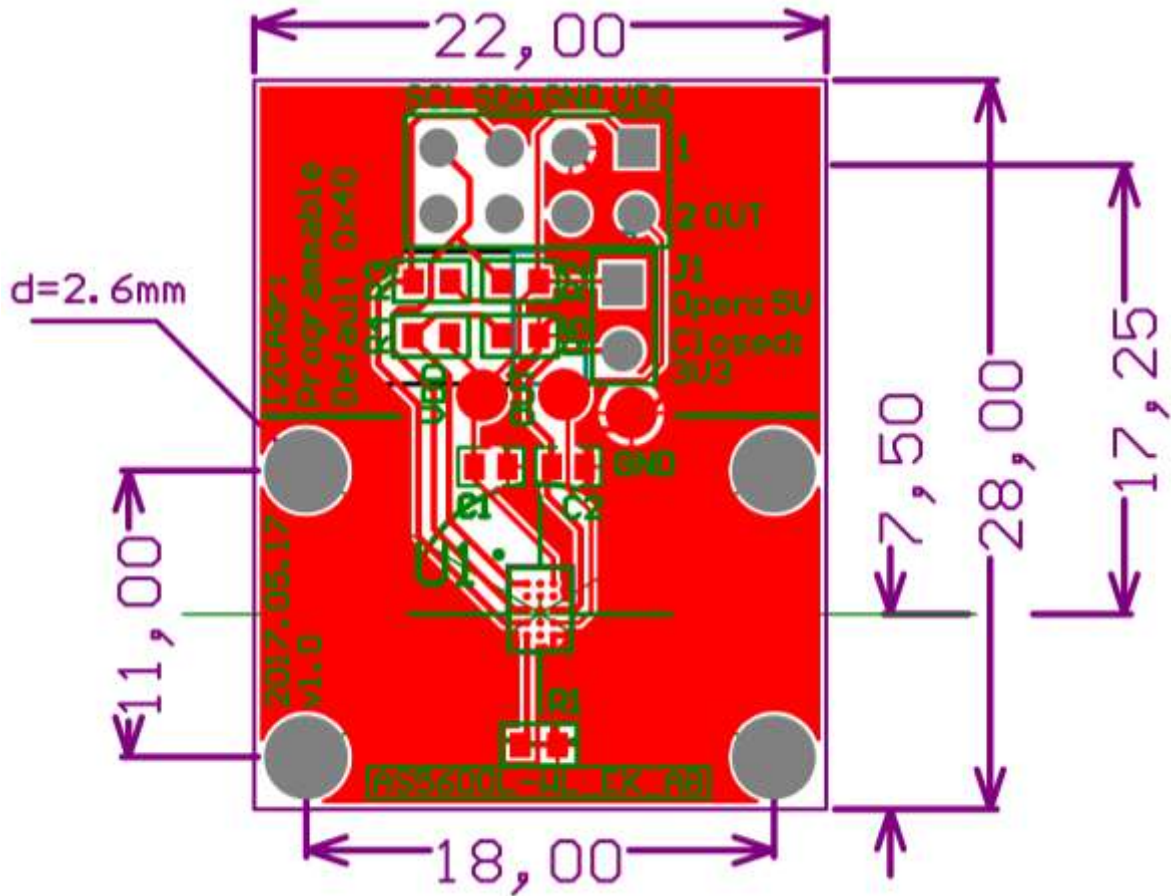

6 Ordering & Contact Information

Ordering Code	Description
AS5600L-WL_EK_AB	AS5600L Eval Kit Adapter Board

Buy our products or get free samples online at:

www.ams.com/ICdirect

Technical Support is available at:

www.ams.com/Technical-Support

Provide feedback about this document at:

www.ams.com/Document-Feedback

For further information and requests, e-mail us at:

ams_sales@ams.com

For sales offices, distributors and representatives, please visit:

www.ams.com/contact

Headquarters

ams AG

Tobelbader Strasse 30

8141 Premstaetten

Austria, Europe

Tel: +43 (0) 3136 500 0

Website: www.ams.com

7 Copyrights & Disclaimer

Copyright ams AG, Tobelbader Strasse 30, 8141 Premstaetten, Austria-Europe. Trademarks Registered. All rights reserved. The material herein may not be reproduced, adapted, merged, translated, stored, or used without the prior written consent of the copyright owner.

Demo Kits, Evaluation Kits and Reference Designs are provided to recipient on an “as is” basis for demonstration and evaluation purposes only and are not considered to be finished end-products intended and fit for general consumer use, commercial applications and applications with special requirements such as but not limited to medical equipment or automotive applications. Demo Kits, Evaluation Kits and Reference Designs have not been tested for compliance with electromagnetic compatibility (EMC) standards and directives, unless otherwise specified. Demo Kits, Evaluation Kits and Reference Designs shall be used by qualified personnel only.

ams AG reserves the right to change functionality and price of Demo Kits, Evaluation Kits and Reference Designs at any time and without notice.

Any express or implied warranties, including, but not limited to the implied warranties of merchantability and fitness for a particular purpose are disclaimed. Any claims and demands and any direct, indirect, incidental, special, exemplary or consequential damages arising from the inadequacy of the provided Demo Kits, Evaluation Kits and Reference Designs or incurred losses of any kind (e.g. loss of use, data or profits or business interruption however caused) as a consequence of their use are excluded.

ams AG shall not be liable to recipient or any third party for any damages, including but not limited to personal injury, property damage, loss of profits, loss of use, interruption of business or indirect, special, incidental or consequential damages, of any kind, in connection with or arising out of the furnishing, performance or use of the technical data herein. No obligation or liability to recipient or any third party shall arise or flow out of ams AG rendering of technical or other services.

8 Revision Information

Changes from previous version to current revision 1-00 (2017-Aug-11)	Page
Initial version 1-00	

Note: Page numbers for the previous version may differ from page numbers in the current revision.
Correction of typographical errors is not explicitly mentioned.

Mouser Electronics

Authorized Distributor

Click to View Pricing, Inventory, Delivery & Lifecycle Information:

[ams OSRAM:](#)

[AS5600L-SO_EK_AB](#)