

# SL13A

## Smart Sensory Tag Chip For Unique Identification, Monitoring and Data Logging

### General Description

The SL13A is a semi-active tag chip optimized for single-cell, battery-powered smart labels with sensor functionality. It also supports fully-passive operation without battery. The chip is ideal for applications using thin and flexible batteries but can also be powered from the RF field (electromagnetic waves from an RFID reader).

The chip has a fully integrated temperature sensor with a nonlinearity of  $\pm 0.5^{\circ}\text{C}$ . The external sensor interface ( $S_{\text{EXT}}$ ) is an analog input and allows the connection of an external sensor.

*Ordering Information and Content Guide appear at end of datasheet.*

### Key Benefits & Features

The benefits and features of SL13A, Smart Sensory Tag Chip For Unique Identification, Monitoring and Data Logging are listed below:

**Figure 1:**  
Added Value of using SL13A

Benefits	Features
Versatile data logging with selectable options	Programmable logging modes High temperature range: $-40^{\circ}\text{C}$ to $110^{\circ}\text{C}$
Logging storage capacity up to 762 events with time stamp	On-chip 8k-bit EEPROM
	Real-time clock (RTC)
Supports data logging from various sensors	On-chip temperature sensor
	Analog input for resistive external sensor
Flexible supply options <b>Note:</b> After battery is exhausted, the chip will continue working in passive mode (no RTC)	Fully passive mode: no battery Semi-passive (BAP) mode: 1.5V or 3V battery
Provides supply for external circuitry	Energy harvesting from reader field providing up to 4mA @3.4V
Long battery life of >1 year (with 25 mAH printed battery)	Standby current (RTC running): $2 \mu\text{A}_{\text{Typ}}$ (@1.5V) Operating current (logging, 20ms): $150 \mu\text{A}_{\text{Typ}}$ (@1.5V)
Works with NFC-enabled phones and HF RFID readers	ISO 15693 /NFC-V compliant cool-Log™ supporting logging functions

Benefits	Features
Parameter setting via serial interface	SPI port (slave) with access to EEPROM
Precludes manipulation and unauthorized usage of data	Perpetual password-protected EEPROM access from reader
Works in multi-tag environment	Anti-collision capability
Flexible delivery form	16-LD QFN (5x5 mm) Tested wafer (8")

### Applications

The SL13A applications include:

- Monitoring and tracking of temperature-sensitive products
- Temperature monitoring of medical products
- Pharmaceutical logistics
- Monitoring of fragile goods transportation

### Block Diagram

The functional blocks of this device for reference are shown below:

Figure 2:  
SL13A Block Diagram

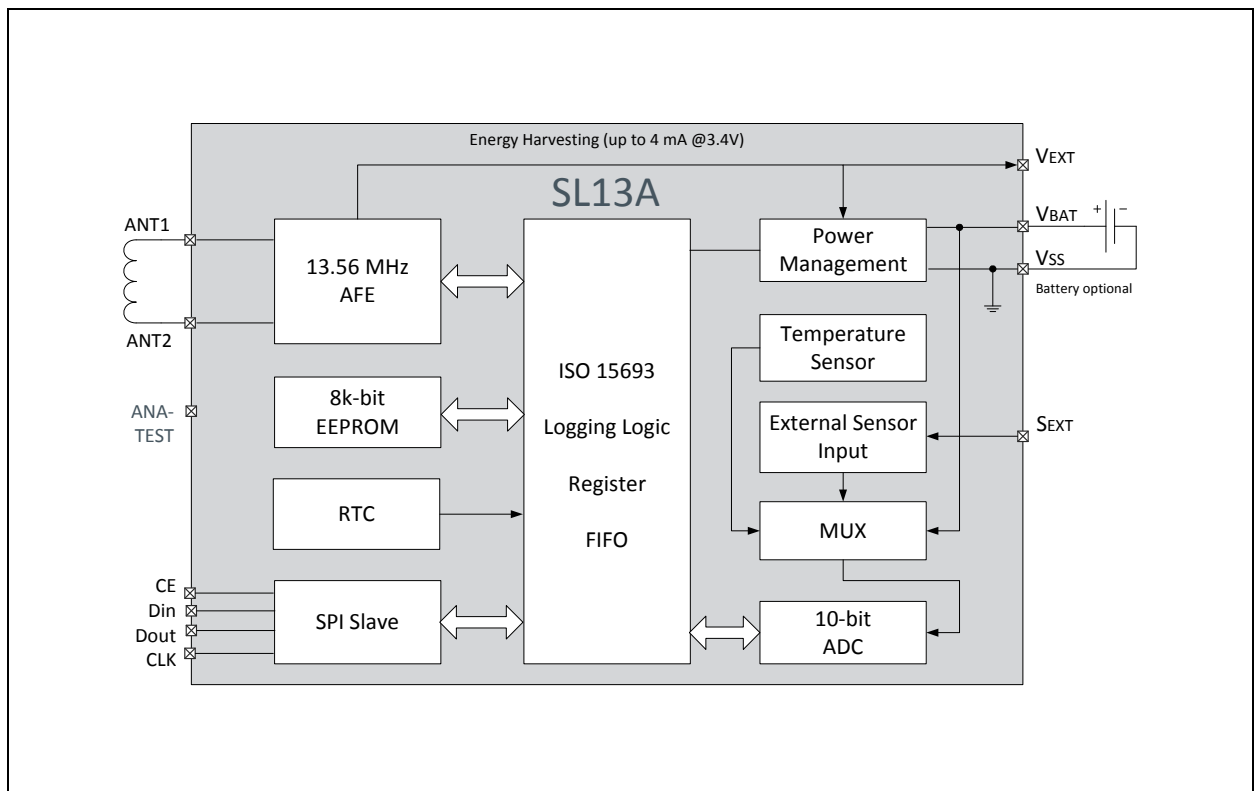

## Pin and Pad Layout

The SL13A pin and pad layout is described below.

**Figure 3:**  
QFN 16 Pinout

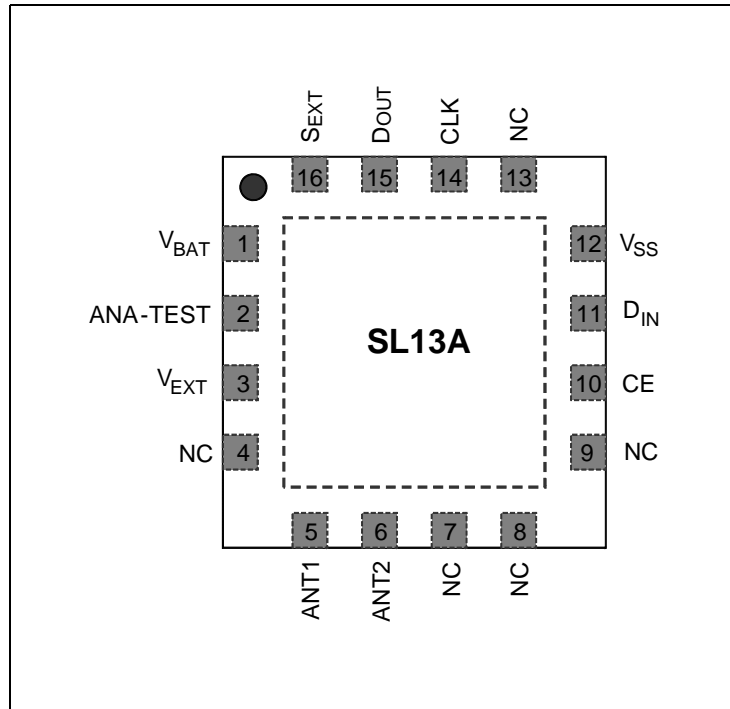

**Figure 4:**  
Die Pad Layout

### Die Pad Layout

All dimensions are in microns. Origin is on lower left corner of the chip, the values show the pad center position.

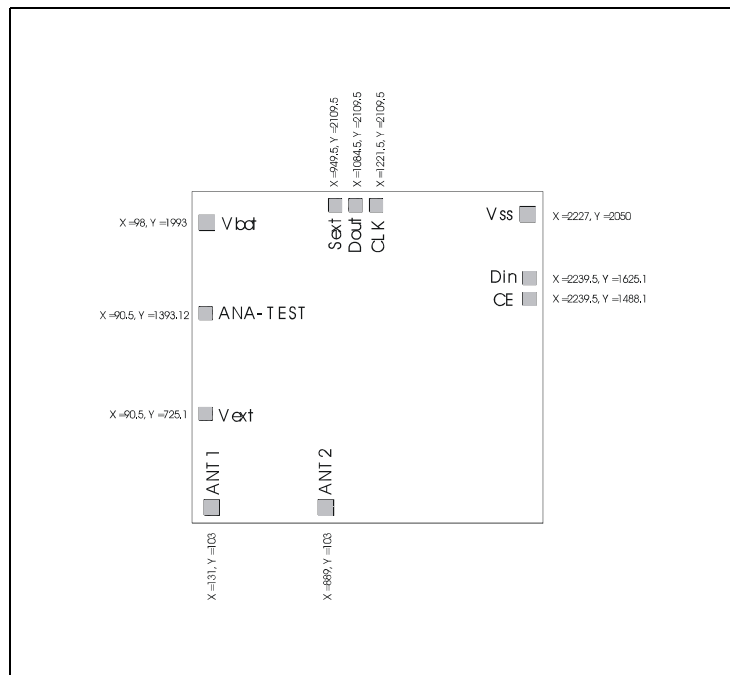

**Figure 5:**  
**Pin Description**

Pin Number	Pin Name	Description
1	V <sub>BAT</sub>	Battery input
2	ANA-TEST	Analog test output
3	V <sub>EXT</sub>	Power output for external circuit (rectified RF voltage)
4	NC	Not connected
5	ANT1	Antenna coil
6	ANT2	Antenna coil
7	NC	Not connected
8	NC	Not connected
9	NC	Not connected
10	CE	SPI enable input
11	D <sub>IN</sub>	SPI data in
12	V <sub>SS</sub>	Negative supply and ground
13	NC	Not connected
14	CLK	SPI clock
15	D <sub>OUT</sub>	SPI data out
16	S <sub>EXT</sub>	Analog input for external sensor. The input voltage range is 0.3V to 0.6V

## Absolute Maximum Ratings

Stresses beyond those listed under “Absolute Maximum Ratings” may cause permanent damage to the device. These are stress ratings only. Functional operation of the device at these or any other conditions beyond those indicated under “Operating Conditions” on page 5 is not implied. Exposure to absolute maximum rating conditions for extended periods may affect device reliability.

**Figure 6:**  
Absolute Maximum Ratings

Parameter	Min	Max	Unit	Note
Input Voltage Range	-0.3	3.7	V	All voltage values are with respect to substrate ground terminal V <sub>SS</sub>
Maximum Current V <sub>EXT</sub> , ANT1, ANT2		1	A	
ESD Rating, HBM		2	kV	
Maximum Operating Virtual Junction Temperature, T <sub>J</sub>		+150	°C	
Storage Temperature Range, T <sub>stg</sub>	-65	+150	°C	
Lead Temperature (soldering, 10 sec.)		+300	°C	

## Operating Conditions

(Operating free-air temperature range)

**Figure 7:**  
Operating Conditions

Symbol	Parameter	Min	Typ	Max	Unit
V <sub>BAT</sub>	Input Supply Voltage	1.2	1.5	3.3	V
T <sub>A</sub>	Operating ambient temperature range	-40		+110	°C

**Electrical Characteristics**

$T_A = 0^\circ\text{C}$  to  $+85^\circ\text{C}$ ,  $V_{\text{BAT}} = 1.5\text{V}$ ,  $\text{EN} = V_{\text{BAT}}$ ,  $R_{\text{LOAD}} = \infty$ , unless otherwise noted. Typical values are at  $T_A = 35^\circ\text{C}$ . <sup>(2)</sup>

**Figure 8:**  
Electrical Characteristics

Symbol	Parameter	Conditions	Min	Typ	Max	Unit
$V_{\text{BAT}}$	Operating Input Voltage	$T_A = 35^\circ\text{C}$	1.2		3.3	V
$V_{\text{BAT(SU)}}$	Minimum Start-Up Input Voltage	$T_A = 35^\circ\text{C}$		1.3		V
$I_{\text{BAT-OP}}$	Operating Current into $V_{\text{BAT}}$	Sensor and A/D converter active	100	150	300	$\mu\text{A}$
$I_{\text{BAT-SD}}$	Shutdown Current into $V_{\text{BAT}}$	$V_{\text{BAT}} = 1.5\text{V}$ ; $T_A = 35^\circ\text{C}$		100	500	nA
$V_{\text{EXT}}$	Output Voltage	see note (1)	3.2	3.4	3.5	V
$I_{\text{EXT}}$	Maximum Current, External	When RF field is present, from the $V_{\text{EXT}}$ pin		4		mA
$V_{\text{IL}}$	Input Voltage Threshold, Low	CE, SCLK, SDATA	$V_{\text{SS}}-0.3$		$V_{\text{SS}}+0.3$	V
$V_{\text{IH}}$	Input Voltage Threshold, High	CE, SCLK, SDATA	$V_{\text{BAT}} - 0.3$		$V_{\text{BAT}} + 0.3$	V
$V_{\text{OL}}$	Output Voltage level, Low	DIGI_OUT	$V_{\text{SS}}-0.3$		$V_{\text{SS}}+0.3$	V
$V_{\text{OH}}$	Output Voltage level, High	DIGI_OUT	$V_{\text{BAT}} - 0.3$		$V_{\text{BAT}} + 0.3$	V
$V_{\text{S-EXT}}$	Sensor Input Voltage Range	$S_{\text{EXT}}$	0.3		0.6	V
$f_c$	Carrier Frequency		13.553	13.56	13.567	MHz
$T_{\text{S-R}}$	Temperature Sensor Range		-20		60	$^\circ\text{C}$
$T_{\text{E-R}}$	Extended temperature sensor range		-40		74	$^\circ\text{C}$
$T_{\text{S-O}}$	Temperature Sensor Offset at $35^\circ\text{C}$	One-point calibration at $35^\circ\text{C}$ <sup>(3)</sup>	-0.6		+0.6	$^\circ\text{C}$
$T_{\text{S-GN}}$	Temperature Sensor Gain and nonlinearity error			$\pm 0.5$		$^\circ\text{C}$
$t_{\text{RTC-I}}$	Real-Time Clock, Interval	Programmable	1		32,768	Sec
$t_{\text{RTC-AT}}$	Real-Time Clock, Accuracy at $35^\circ\text{C}$	see note (4)	-0.5		+0.5	%

Symbol	Parameter	Conditions	Min	Typ	Max	Unit
$t_{\text{RTC-AF}}$	Real-Time Clock, Accuracy over the specified temperature range		-3		+3	%
$EW_{\text{CYC}}$	EEPROM Erase/Write Cycles	$T = 25^{\circ}\text{C}$	10,000			Cycles
$t_{\text{DR}}$	EEPROM Data Retention Time	$T = 55^{\circ}\text{C}$	10			Years
$t_{\text{E/W}}$	EEPROM Erase/Write Time	$T_{\text{A}} = 0^{\circ}$ to $55^{\circ}\text{C}$	4	6	8	ms
$C_{\text{T}}$	Internal Tuning Capacitor	Between ANT1 and ANT2 pins		25		pF

**Note(s) and/or Footnote(s):**

1.  $V_{\text{EXT}}$  is rectified RF voltage, for power supply of external circuits. It is limited to 3.4V, when enough signal is present on the coil. The maximum output current is 5mA and is dependent on the strength of the RF field.
2. Limits are 100% production tested at  $T_{\text{A}} = 35^{\circ}\text{C}$ . Limits over the operating temperature range are guaranteed by design.
3. During calibration on wafer sort, the chuck temperature variation is  $\pm 0.5^{\circ}\text{C}$ , which amounts to the major part of the accuracy error.
4. The real time oscillator frequency is trimmed on wafer sort at  $35^{\circ}\text{C}$ .

## Detailed Description

The SL13A is designed for use in smart active labels (SAL) and smart passive labels. Smart active labels are defined as thin and flexible labels that contain an integrated circuit and a power source. SAL includes in its definition both “fully active” smart labels, and semi-active smart labels, also known as battery-assisted back-scattered passive labels, both of which enable enhanced functionality and superior performance over existing passive labels. The SL13A can be used in semi-active or fully-passive smart labels. The IC includes sensor functionality and logging of sensor data (see Figure 1 below).

The SL13A is operating at 13.56 MHz and is fully ISO 15693 compliant. The chip is supplied from a single-cell battery of typically 1.5V. The on-chip temperature sensor and real-time clock (RTC) accommodate temperature data logging.

### Supply Arrangement

The SL13A is supplied from either the battery or through the electromagnetic waves from a reader. The device is normally supplied from the battery unless the battery voltage is too low - in this case the device is powered from the RF field. This functionality enables the read out of the log data even in case the battery is exhausted.

The chip automatically detects whether a 1.5V or 3V battery is connected and adapts accordingly. The voltage step-up converter provides an input voltage for the voltage regulator, which provides a regulated voltage of 2V nominal (internal digital supply). The maximum current available from  $V_{EXT}$  for external circuitry is 4mA (only when RF field is present) and is limited to 3.4V.

### Analog Front End (AFE)

The analog front end is designed for 13.56 MHz according to ISO 15693. The incoming data are demodulated from the received ASK (Amplitude Shift Keying) signal which is 10 ~ 30% or 100% modulated. Outgoing data are generated by the SL13A load variation using Manchester coding with one or two sub-carrier frequencies of 423.75 KHz ( $f_c/32$ ) or 484.28 KHz ( $f_c/28$ ). The SL13A is compliant with the ISO 15693 recommendation for radio frequency power and signal interface.



## Processing and Digital Control

The SL13A is fully ISO 15693 compliant. Both data coding modes (1 out of 256 and 1 out of 4) are supported by the SL13A. The reader (interrogator) makes mode selection within the SOF (Start of Frame).

The 1-of-256 data coding mode has a data rate of 1.65 kbit/s ( $f_c/8192$ ) meaning that the transmission of one byte takes 4.833 ms. The 1-of-4 coding has a rate of 26.48 kbit/s ( $f_c/512$ ) with the transmission of one byte taken 302.08  $\mu$ s.

**Figure 9:**  
Response Data Rate

Data Rate	One Sub-carrier	Two Sub-carrier
Low	6.62 kbit/s ( $f_c/2048$ )	6.67 kbit/s ( $f_c/2032$ )
High	26.48 kbit/s ( $f_c/512$ )	26.69 kbit/s ( $f_c/508$ )

## Serial Interface (SPI)

The integrated serial interface (SPI) can be used to read and write the embedded EEPROM and to set the parameters. The SPI interface is a secondary and test interface - the main interface is the RF ISO15693 interface.

## Real-Time Clock (RTC)

The on-chip real-time clock (RTC) is started through the **START-LOG** command in which the start time is programmed in UTC format. The interval for sensing and data logging can be programmed in the range from 1 second up to 9 hours. The accuracy of the timer is  $\pm 3\%$ .

## Temperature Sensor

The on-chip temperature sensor can measure the temperature in the range from  $-20^\circ\text{C}$  to  $60^\circ\text{C}$  within the specified accuracy. The reference voltage for the A/D conversion is supplied from an on chip calibrated Bandgap reference.

## External Sensor

The external sensor pin ( $S_{EXT}$ ) can be used to connect an external sensor to the A/D converter. The voltage input range is 300mV – 600mV and is fixed. For extra low power applications the CE pin can switch the battery voltage for the time of the external sensor A/D converter, so the current from the battery into the sensor will flow only for this short time (max 5ms). This can be enabled when the External-sensor flag is set to 1 and the bit 19 in the Internal calibration data is set.

## **A/D Converter**

An integrated 10-bit dual slope converter is used for the temperature, battery and external sensor voltage conversions.

## ***EEPROM Organization and Security***

The EEPROM is organized into 3 areas - the System area, User area and Measurement area. The System area has a fixed size and can be accessed only by the proprietary commands. It is protected by the Level 1 password - the System password. The User and Measurement areas reside in the same address space (256 blocks), but have separated passwords - the User password and the Measurement password. The User and Measurement areas can be accessed by the standard ISO15693 read and write commands. The User area size can be set by the Initialize command. The minimum User area size is 1 block, the maximum is 256 blocks. The size of the Measurement area is 256 blocks minus User area. All blocks are 32 bits wide.

The password protection restricts only the write-type commands. Read commands are always open. The password protection can be activated for every area individually by writing a value not equal to 0 to the password blocks.

The chip also supports a One-time use secure mode. When this mode is used, all Measurement blocks are automatically locked by the chip with the Start Log command. Those blocks cannot be unlocked anymore even if the Level 3 (measurement) password is known. This mode is intended for high security applications where the 32-bit password does not provide enough confidence.

## **Fully Passive Operation**

The chip can be used in fully passive mode without a battery supply. In this mode all functions are active only when the antenna is in a RF field. For extended operation range in fully passive mode, connect a 2.2 $\mu$ F capacitor between the V<sub>EXT</sub> and V<sub>SS</sub> pins. The chip can be used also without this capacitor.

## Functional Description

Figure 11, “State Transition Diagram,” on page 13 shows the command overview.

Figure 14, “cool-Log™ Command Overview,” on page 14 shows the different states and their interactions.

### Initializing the Chip

A virgin chip (not initialized) can be initialized either through the SPI bus or through the electromagnetic field from a reader in the standby mode. The power source is either from a battery ( $V_{BAT}$ ) or extracted from the RF field via the AFE circuit. After the initializing procedure, the chip will enter the ready mode.

If the External-Sensor flag is set, an external analog output sensor can be connected to the  $S_{EXT}$  pin.

### Ready State

In the ready mode, all parameters can be set, read and changed through a reader with the appropriate passwords.

### Active State

In active mode, the real-time clock (RTC) is running, the desired parameters are set and the on-chip temperature sensor is in standby.

### Logging State

A log flag from the timer will enable the logging mode in which the sensor and the A/D converter will be activated, and the measured value will be stored in the EEPROM together with the time of the event. If the External Sensor flag is set, the external sensor will also be activated and the measured data stored. The A/D converter can be multiplexed between internal temperature sensor, external sensor or battery voltage. After the event, the chip will return to the active mode.

During the time of the logging procedure, the chip will not be able to receive any RF command. If an RF command is sent during this time, the chip will ignore it and will not send any reply.

### Passive State

In passive mode, the chip waits for the presence of an RF field or for CE signal to go high. Current consumption from the battery in passive mode is <300nA.

**Figure 10:**  
Overview of Operation States

State	CE	Description	$I_{BAT}$ (Typ.)	Power from AFE
Passive	Low	Chip in passive state No current into $V_{BAT}$	<0.1 $\mu A$	No
Serial	High	Enables initializing and executing of all commands via the SPI bus		No
Ready	Low	Chip is initialized and all commands can be executed via the reader		Yes
Active	Low	RTC running Sensor standby	3 $\mu A$	No
Logging	Low	Sensor reading (on-chip temperature sensor, battery voltage level and/or external sensor through the $S_{EXT}$ pin) Measured data stored in EEPROM RTC time stored in EEPROM	100 $\mu A$	No

## State Diagram

Figure 11:  
State Transition Diagram

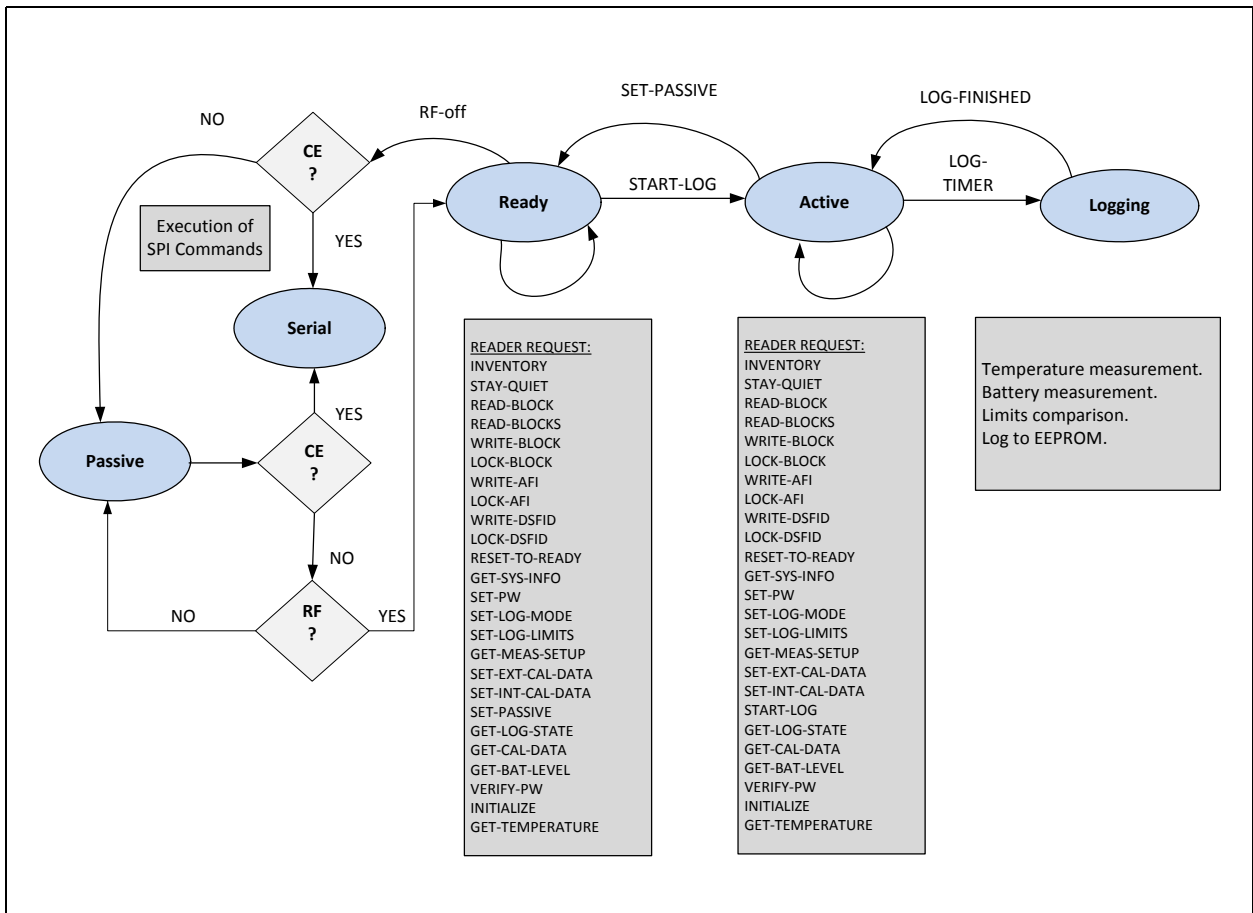

## Commands

### Request Command Structure

All commands, the standard ISO15693 and the cool-Log™ commands, have the same structure. All fields are sent LSbit first.

Figure 12:  
Request Command Structure

SOF	Flags	Command Code	Parameters / Data	CRC	EOF
	8 bits	8 bits	n*8 bits	16 bits	

## Response Structure

Figure 13:  
Response Structure

SOF	Flags	Parameters / Data	CRC	EOF
	8 bits	n*8 bits	16 bits	

Figure 14:  
cool-Log™ Command Overview

#	Command	Command Code	Allowed in Modes					Mode Change	Security Level	Definition
			Logging	Serial	Ready	Active	Passive			
01	Inventory	0x01	-	√	√	√	-	No	0	Multi-tag request, anti-collision
02	Stay Quiet	0x02	-	√	√	√	-	Yes	0	Sets the chip to quiet state within its basic mode
03	Read Block	0x20	-	√	√	√	-	No	0	Reads the requested block
04	Read Blocks	0x23	-	√	√	√	-	No	0	Reads the requested blocks
05	Write Block	0x21	-	√	√	√	-	No	2 or 3	Writes the requested block
06	Lock Block	0x22	-	√	√	√	-	No	2 or 3	Locks the requested block
07	Write AFI	0x27	-	√	√	√	-	No	1	Writes AFI (application family identifier) number into chip
08	Lock AFI	0x28	-	√	√	√	-	No	1	Locks the AFI block
09	Write DSF	0x29	-	√	√	√	-	No	1	Writes the DSF (data storage format) number into the chip
10	Lock DSFID	0x2A	-	√	√	√	-	No	1	Locks the DSFID block
11	Reset to ready	0x26	-	√	√	√	-	Yes	0	Resets from Quiet state
12	Get System Info	0x2B	-	√	√	√	-	No	0	Read the System information block
13	Set PW	0xA0	-	√	√	√	-	No	1, 2, 3	Sets the passwords to EEPROM or opens access to the requested area
14	Set Log Mode	0xA1	-	√	√	-	-	No	1	Sets logging mode
15	Set Log Limits	0xA2	-	√	√	-	-	No	1	Sets the measurement limits for limits logging mode

#	Command	Command Code	Allowed in Modes					Mode Change	Security Level	Definition
			Logging	Serial	Ready	Active	Passive			
16	Get measurement setup	0xA3	-	√	√	√	-	No	0	Reads 4 system blocks - Start time, Log limits, Log mode, and Delay time + user area size
17	Set Ext. Calibration data	0xA4	-	√	√	-	-	No	1	Sets the calibration data for the external sensor
18	Set Int. calibration Data	0xA5	-	√	√	-	-	No	1	Sets the calibration data for the temperature sensor and timer
19	Set Passive	0xA6	-	√	-	√	-	Yes	1	Stops the log procedure and returns the chip to Standby mode
20	Start Log	0xA7	-	√	√	-	-	Yes	1	Starts the timer and the selected log procedure
21	Get Log State	0xA8	-	√	√	√	-	No	1	Gets the log state of the chip
22	Get calibration data	0xA9	-	√	√	√	-	No	0	Reads the internal and external calibration data
23	Get Battery level	0xAA	-	√	√	√	-	No	0	Measures the battery voltage
24	Verify PW	0xAB	-	√	√	√	-	No	0	Verifies the password for the requested area
25	Initialize	0xAC	-	√	√	-	-	No	0	Initializes the chip and sets the user area size and the logging delay
26	Get temperature	0xAD	-	√	√	√	-	No	0	Measures the temperature

## Command Description

The commands are described below in detail.

- Inventory - #01  
After receiving an **INVENTORY** request, all chips respond with their respective unique serial numbers (UID). One slot and multiple slot for anti-collision is supported.
- Stay Quiet - #02  
When a chip receives a **STAY-QUIET** command, it enters the quiet state. In this state, the chip will not respond to Inventory commands. The chip leaves the Quiet state after receiving the Reset to Ready command.
- Read Block - #03  
A memory block can be read with the **READ-BLOCK** command. Only the User and Measurement area are accessed by this command.
- Read Blocks - #04  
Multiple blocks can be read with the **READ-BLOCKS** command. The maximum numbers of blocks in this command is 256.
- Write Block - #05  
The **WRITE-BLOCK** command writes the requested block with the data contained in the request. Only User and Measurement data are accessed by this command.  
Security levels: 2 for User data and 3 for Measurement data.
- Lock Block - #06  
The **LOCK-BLOCK** command locks the requested block in the User and Measurement area. A locked block is permanently locked and cannot be unlocked anymore.  
Security levels: 2 for User area and 3 for Measurement area.
- Write AFI - #07  
The **WRITE-AFI** command writes the AFI number (application family identifier) into the memory.  
Security level 1.
- Lock AFI - #08  
The **LOCK-AFI** command locks the AFI block. It cannot be unlocked anymore.  
Security level 1.
- Write DSFID - #09  
The **WRITE-DSF** command is used to write the DSF (data storage format) number into the memory.  
Security level 1.



- Lock DSFID - #10  
The **LOCK-DSFID** command locks the DSFID block. It cannot be unlocked anymore.  
Security level 1.
  
- Reset to Ready - #11  
The **RESET-TO-READY** command puts the chip from Quiet to Ready state. It is effective only in Quiet state.
  
- Get System Info - #12  
The **GET-SYSTEM-INFO** command gets the system information of the chip, including info flags, UID, chip revision, blocks and size.
  
- Set PW - #13  
The **SET-PW** command sets the passwords for the selected password level. The passwords are parallel, which means that the user can protect individual areas and not affect the other areas.  
Security levels 1, 2 or 3, respectively.

**Figure 15:**  
**Security Levels Explained**

Security Level	Password	Access
0	No	All open
1	System password	System area
2	User password	User area
3	Measurement password	Measurement area

- Set Log Mode - #14  
The **SET-LOG-MODE** command defines the sensor type (internal/external sensors), logging form, extreme upper limit and storage rules.  
Security level 1.
  
- Set Log Limits - #15  
The **SET-LOG-LIMITS** command sets the logging higher, lower and extreme lower limits. Those limits are used in the Limits modes and ignored in the Dense mode.  
Security level 1.
  
- Get Measurement Setup - #16  
The **GET-MEASUREMENT-SETUP** command reads 4 system blocks - Start time, Log limits, Log mode and Delay time.

- Set External Calibration Data - #17  
The **SET-EXT-CAL-DATA** command sets the user calibration values. Those values have no effect on the internal calibration settings.  
Security level 1.
- Set Internal Calibration Data - #18  
The **SET-INT-CAL-DATA** command sets the calibration values for the internal temperature sensor.  
Security level 1.
- Set Passive - #19  
The **SET-PASSIVE** command stops the logging procedure and returns the chip to passive mode. It also stops the timer.  
Security level 1.
- Start Log - #20  
The **START-LOG** command starts the logging procedure and sets the Start time in UTC format. In logging state the chips automatically performs the measurements and data logging in the specified time intervals. Supported is also a delayed start, which means that the chip will start with the logging procedure with a specified delay after it receives the **START-LOG** command.  
Security level 1.
- Get Log State - #21  
The **GET-LOG-STATE** command gets the log state of following parameters: measurement status and out of limits counter. This gives the ability to quickly check the state of the package without the need to read the whole temperature data log.
- Get Calibration Data - #22  
The **GET-CALIBRATION** command reads the calibration data for the internal and external sensors.
- Get Battery Level - #23  
The **GET-BAT-LEVEL** command measures and reads the voltage level of the battery.
- Verify PW - #24  
The **VERIFY-PW** command is used to verify the various passwords.

- Initialize - #25  
 The **INITIALIZE** command sets the size of the user data area and sets the delay time. If the Secure flag is set, the chip automatically locks all measurement blocks. The command clears the measurement status and limits counter blocks.  
 Security level 1.
- Get temperature - #26  
 The **GET-TEMPERATURE** command measures and reads the current chip temperature. *The measured temperature can be higher than the environment temperature, because of the chip self-heating through the reader RF field. To ensure correct measurement, the reader has to send this command as soon as possible after the RF field is turned on.*

### Inventory - #01

Request:

<b>SOF</b>	<b>FLAGS</b> 8 bits	<b>COMMAND CODE</b> 0x01	<b>MASK LENGTH</b> 8 bits	<b>MASK VALUE</b> 0 - 64 bits	<b>CRC</b> 16 bits	<b>EOF</b>
------------	------------------------	-----------------------------	------------------------------	----------------------------------	-----------------------	------------

**Note:** The AFI field is not supported by the SL13A.

Reply:

<b>SOF</b>	<b>FLAGS</b> 8 bits	<b>DSFID</b> 8 bits	<b>UID</b> 64 bits	<b>CRC</b> 16 bits	<b>EOF</b>
------------	------------------------	------------------------	-----------------------	-----------------------	------------

**Note:** The manufacturers ID is 0x36. The UID consists of 8 bytes: E0 36 XX XX XX XX XX XX.

### Stay Quiet - #02

Request:

<b>SOF</b>	<b>FLAGS</b> 8 bits	<b>COMMAND CODE</b> 0x02	<b>UID</b> 64 bits	<b>CRC</b> 16 bits	<b>EOF</b>
------------	------------------------	-----------------------------	-----------------------	-----------------------	------------

No Reply.

**Read Block - #03**

Request:

<b>SOF</b>	<b>FLAGS</b> 8 bits	<b>COMMAND CODE</b> 0x20	<b>UID</b> 64 bits	<b>BLOCK ADDRESS</b> 8 bits	<b>CRC</b> 16 bits	<b>EOF</b>
------------	------------------------	-----------------------------	-----------------------	--------------------------------	-----------------------	------------

Reply:

<b>SOF</b>	<b>FLAGS</b> 8 bits	<b>BLOCK SECURITY STATUS</b> 8 bits	<b>DATA</b> 32 bits	<b>CRC</b> 16 bits	<b>EOF</b>
------------	------------------------	--	------------------------	-----------------------	------------

**Read Blocks - #04**

Request:

<b>SOF</b>	<b>FLAGS</b> 8 bits	<b>COMMAND CODE</b> 0x23	<b>UID</b> 64 bits	<b>BLOCK ADDRESS</b> 8 bits	<b>NUMBER OF BLOCKS</b> 8 bits	<b>CRC</b> 16 bits	<b>EOF</b>
------------	------------------------	-----------------------------	-----------------------	--------------------------------	-----------------------------------	-----------------------	------------

Reply:

<b>SOF</b>	<b>FLAGS</b> 8 bits	<b>BLOCK SECURITY STATUS</b> 8 bits	<b>DATA</b> 32 bits	<b>CRC</b> 16 bits	<b>EOF</b>
			Repeat As Requested		

**Write Block - #05**

Request:

<b>SOF</b>	<b>FLAGS</b> 8 bits	<b>COMMAND CODE</b> 0x21	<b>UID</b> 64 bits	<b>BLOCK ADDRESS</b> 8 bits	<b>DATA</b> 32 bits	<b>CRC</b> 16 bits	<b>EOF</b>
------------	------------------------	-----------------------------	-----------------------	--------------------------------	------------------------	-----------------------	------------

Reply:

<b>SOF</b>	<b>FLAGS</b> 8 bits	<b>CRC</b> 16 bits	<b>EOF</b>
------------	------------------------	-----------------------	------------

**Lock Block - #06**

Request:

<b>SOF</b>	<b>FLAGS</b> 8 bits	<b>COMMAND CODE</b> 0x22	<b>UID</b> 64 bits	<b>BLOCK ADDRESS</b> 8 bits	<b>CRC</b> 16 bits	<b>EOF</b>
------------	------------------------	-----------------------------	-----------------------	--------------------------------	-----------------------	------------

Reply:

<b>SOF</b>	<b>FLAGS</b> 8 bits	<b>CRC</b> 16 bits	<b>EOF</b>
------------	------------------------	-----------------------	------------

**Write AFI - #07**

Request:

<b>SOF</b>	<b>FLAGS</b> 8 bits	<b>COMMAND CODE</b> 0x27	<b>UID</b> 64 bits	<b>AFI</b> 8 bits	<b>CRC</b> 16 bits	<b>EOF</b>
------------	------------------------	-----------------------------	-----------------------	----------------------	-----------------------	------------

Reply:

<b>SOF</b>	<b>FLAGS</b> 8 bits	<b>CRC</b> 16 bits	<b>EOF</b>
------------	------------------------	-----------------------	------------

**Lock AFI - #08**

Request:

<b>SOF</b>	<b>FLAGS</b> 8 bits	<b>COMMAND CODE</b> 0x28	<b>UID</b> 64 bits	<b>CRC</b> 16 bits	<b>EOF</b>
------------	------------------------	-----------------------------	-----------------------	-----------------------	------------

Reply:

<b>SOF</b>	<b>FLAGS</b> 8 bits	<b>CRC</b> 16 bits	<b>EOF</b>
------------	------------------------	-----------------------	------------

**Write DSFID - #09**

Request:

<b>SOF</b>	<b>FLAGS</b> 8 bits	<b>COMMAND CODE</b> 0x29	<b>UID</b> 64 bits	<b>DSIF</b> 8 bits	<b>CRC</b> 16 bits	<b>EOF</b>
------------	------------------------	-----------------------------	-----------------------	-----------------------	-----------------------	------------

Reply:

<b>SOF</b>	<b>FLAGS</b> 8 bits	<b>CRC</b> 16 bits	<b>EOF</b>
------------	------------------------	-----------------------	------------

**Lock DSFID - #10**

Request:

<b>SOF</b>	<b>FLAGS</b> 8 bits	<b>COMMAND CODE</b> 0x2A	<b>UID</b> 64 bits	<b>CRC</b> 16 bits	<b>EOF</b>
------------	------------------------	-----------------------------	-----------------------	-----------------------	------------

Reply:

<b>SOF</b>	<b>FLAGS</b> 8 bits	<b>CRC</b> 16 bits	<b>EOF</b>
------------	------------------------	-----------------------	------------

**Reset to Ready - #11**

Request:

<b>SOF</b>	<b>FLAGS</b> 8 bits	<b>COMMAND CODE</b> 0x26	<b>UID</b> 64 bits	<b>CRC</b> 16 bits	<b>EOF</b>
------------	------------------------	-----------------------------	-----------------------	-----------------------	------------

Reply:

<b>SOF</b>	<b>FLAGS</b> 8 bits	<b>CRC</b> 16 bits	<b>EOF</b>
------------	------------------------	-----------------------	------------

**Get System Info - #12**

Request:

<b>SOF</b>	<b>FLAGS</b> 8 bits	<b>COMMAND CODE</b> 0x2B	<b>UID</b> 64 bits	<b>CRC</b> 16 bits	<b>EOF</b>
------------	------------------------	-----------------------------	-----------------------	-----------------------	------------

Reply:

<b>SOF</b>	<b>FLAGS</b> 8 bits	<b>INFO FLAGS</b> 8 bits	<b>UID</b> 64 bits	<b>DSFID</b> 8 bits	<b>AFI</b> 8 bits	<b>TAG MEMORY SIZE</b> 16 bits	<b>IC REFERENCE</b> 8 bits	<b>CRC</b> 16 bits	<b>EOF</b>
------------	------------------------	-----------------------------	-----------------------	------------------------	----------------------	-----------------------------------	-------------------------------	-----------------------	------------

Tag memory size field:

MSbit								LSbit
15	13	12	8	7	0			
RFU		BLOCK SIZE			NUMBER OF CLOCKS			

### Set Password - #13

Request:

<b>SOF</b>	<b>FLAGS</b> 8 bits	<b>COMMAND CODE</b> 0xA0	<b>UID</b> 64 bits	<b>PASSWORD LEVEL</b> 8 bits	<b>PASSWORD</b> 32 bits	<b>CRC</b> 16 bits	<b>EOF</b>
------------	------------------------	-----------------------------	-----------------------	---------------------------------	----------------------------	-----------------------	------------

Reply:

<b>SOF</b>	<b>FLAGS</b> 8 bits	<b>CRC</b> 16 bits	<b>EOF</b>
------------	------------------------	-----------------------	------------

Password Level Field:

b0	b1	Password level
0	1	Level 1 - System
1	0	Level 2 - User
1	1	Level 3 - Measurement

b7	Operation
0	Open area
1	Write password

**Set Password:** bit6 - bit2 are all 0.

When bit7 of the Password level field is set to 1, the password is written to the requested level in the EEPROM. This operation enables password protection for the requested area, if the password is not 0. When the bit7 of the Password level field is 0, the requested area is opened with the included password. This command will not send back any error message, if the included password is not correct. One can verify the password with the Verify Password command.

### Set Log Mode - #14

Request:

<b>SOF</b>	<b>FLAGS</b> 8 bits	<b>COMMAND CODE</b> 0xA1	<b>UID</b> 64 bits	<b>LOG MODE</b> 32 bits	<b>CRC</b> 16 bits	<b>EOF</b>
------------	------------------------	-----------------------------	-----------------------	----------------------------	-----------------------	------------

Reply:

<b>SOF</b>	<b>FLAGS</b> 8 bits	<b>CRC</b> 16 bits	<b>EOF</b>
------------	------------------------	-----------------------	------------

**Set Log Limits - #15**

Request:

<b>SOF</b>	<b>FLAGS</b> 8 bits	<b>COMMAND CODE</b> 0xA2	<b>UID</b> 64 bits	<b>LOG LIMITS</b> 32 bits	<b>CRC</b> 16 bits	<b>EOF</b>
------------	------------------------	-----------------------------	-----------------------	------------------------------	-----------------------	------------

Reply:

<b>SOF</b>	<b>FLAGS</b> 8 bits	<b>CRC</b> 16 bits	<b>EOF</b>
------------	------------------------	-----------------------	------------

**Get Measurement Setup - #16**

Request:

<b>SOF</b>	<b>FLAGS</b> 8 bits	<b>COMMAND CODE</b> 0xA3	<b>UID</b> 64 bits	<b>CRC</b> 16 bits	<b>EOF</b>
------------	------------------------	-----------------------------	-----------------------	-----------------------	------------

Reply:

<b>SOF</b>	<b>FLAGS</b> 8 bits	<b>START TIME</b> 32 bits	<b>LOG LIMITS</b> 32 bits	<b>LOG MODE</b> 32 bits	<b>DELAY TIME</b> 32 bits	<b>CRC</b> 16 bits	<b>EOF</b>
------------	------------------------	------------------------------	------------------------------	----------------------------	------------------------------	-----------------------	------------

**Set External Calibration Data - #17**

Request:

<b>SOF</b>	<b>FLAGS</b> 8 bits	<b>COMMAND CODE</b> 0xA4	<b>UID</b> 64 bits	<b>EX. CAL. DATA</b> 32 bits	<b>CRC</b> 16 bits	<b>EOF</b>
------------	------------------------	-----------------------------	-----------------------	---------------------------------	-----------------------	------------

Reply:

<b>SOF</b>	<b>FLAGS</b> 8 bits	<b>CRC</b> 16 bits	<b>EOF</b>
------------	------------------------	-----------------------	------------



**Set Internal Calibration Data - #18**

Request:

<b>SOF</b>	<b>FLAGS</b> 8 bits	<b>COMMAND CODE</b> 0xA5	<b>UID</b> 64 bits	<b>IN. CAL. DATA</b> 32 bits	<b>CRC</b> 16 bits	<b>EOF</b>
------------	------------------------	-----------------------------	-----------------------	---------------------------------	-----------------------	------------

Reply:

<b>SOF</b>	<b>FLAGS</b> 8 bits	<b>CRC</b> 16 bits	<b>EOF</b>
------------	------------------------	-----------------------	------------

**Set Passive - #19**

Request:

<b>SOF</b>	<b>FLAGS</b> 8 bits	<b>COMMAND CODE</b> 0xA6	<b>UID</b> 64 bits	<b>CRC</b> 16 bits	<b>EOF</b>
------------	------------------------	-----------------------------	-----------------------	-----------------------	------------

Reply:

<b>SOF</b>	<b>FLAGS</b> 8 bits	<b>CRC</b> 16 bits	<b>EOF</b>
------------	------------------------	-----------------------	------------

**Start Log - #20**

Request:

<b>SOF</b>	<b>FLAGS</b> 8 bits	<b>COMMAND CODE</b> 0xA7	<b>UID</b> 64 bits	<b>START TIME</b> 32 bits	<b>CRC</b> 16 bits	<b>EOF</b>
------------	------------------------	-----------------------------	-----------------------	------------------------------	-----------------------	------------

Reply:

<b>SOF</b>	<b>FLAGS</b> 8 bits	<b>CRC</b> 16 bits	<b>EOF</b>
------------	------------------------	-----------------------	------------

### Get Log State - #21

Request:

<b>SOF</b>	<b>FLAGS</b> 8 bits	<b>COMMAND CODE</b> 0xA8	<b>UID</b> 64 bits	<b>CRC</b> 16 bits	<b>EOF</b>
------------	------------------------	-----------------------------	-----------------------	-----------------------	------------

Reply:

<b>SOF</b>	<b>FLAGS</b> 8 bits	<b>MEASUREMENT STATUS</b> 32 bits	<b>LIMITS COUNTER</b> 32 bits	<b>CRC</b> 16 bits	<b>EOF</b>
------------	------------------------	--------------------------------------	----------------------------------	-----------------------	------------

### Get Calibration Data - #22

Request:

<b>SOF</b>	<b>FLAGS</b> 8 bits	<b>COMMAND CODE</b> 0xA9	<b>UID</b> 64 bits	<b>CRC</b> 16 bits	<b>EOF</b>
------------	------------------------	-----------------------------	-----------------------	-----------------------	------------

Reply:

<b>SOF</b>	<b>FLAGS</b> 8 bits	<b>INT. CAL. DATA</b> 32 bits	<b>EXT. CAL. DATA</b> 32 bits	<b>CRC</b> 16 bits	<b>EOF</b>
------------	------------------------	----------------------------------	----------------------------------	-----------------------	------------

### Get Battery Level - #23

Request:

<b>SOF</b>	<b>FLAGS</b> 8 bits	<b>COMMAND CODE</b> 0xAA	<b>UID</b> 64 bits	<b>CRC</b> 16 bits	<b>EOF</b>
------------	------------------------	-----------------------------	-----------------------	-----------------------	------------

Reply:

<b>SOF</b>	<b>FLAGS</b> 8 bits	<b>BATTERY LEVEL</b> 8 bits	<b>CRC</b> 16 bits	<b>EOF</b>
------------	------------------------	--------------------------------	-----------------------	------------

**Verify Password - #24**

Request:

<b>SOF</b>	<b>FLAGS</b> 8 bits	<b>COMMAND CODE</b> 0xAB	<b>UID</b> 64 bits	<b>PASSWORD LEVEL</b> 8 bits	<b>CRC</b> 16 bits	<b>EOF</b>
------------	------------------------	-----------------------------	-----------------------	---------------------------------	-----------------------	------------

Reply:

<b>SOF</b>	<b>FLAGS</b> 8 bits	<b>CRC</b> 16 bits	<b>EOF</b>
------------	------------------------	-----------------------	------------

**Initialize - #25**

Request:

<b>SOF</b>	<b>FLAGS</b> 8 bits	<b>COMMAND CODE</b> 0xAC	<b>UID</b> 64 bits	<b>DELAY TIME AND #OF USER BLOCKS</b> 32 bits	<b>CRC</b> 16 bits	<b>EOF</b>
------------	------------------------	-----------------------------	-----------------------	--	-----------------------	------------

Reply:

<b>SOF</b>	<b>FLAGS</b> 8 bits	<b>CRC</b> 16 bits	<b>EOF</b>
------------	------------------------	-----------------------	------------

**Get Temperature - #26**

Request:

<b>SOF</b>	<b>FLAGS</b> 8 bits	<b>COMMAND CODE</b> 0xAD	<b>UID</b> 64 bits	<b>CRC</b> 16 bits	<b>EOF</b>
------------	------------------------	-----------------------------	-----------------------	-----------------------	------------

Reply:

<b>SOF</b>	<b>FLAGS</b> 8 bits	<b>TEMPERATURE</b> 16 bits	<b>CRC</b> 16 bits	<b>EOF</b>
------------	------------------------	-------------------------------	-----------------------	------------

### Flags

The request flags are the same for all specified commands, except for the Inventory command. Flags for the Inventory command are defined in the table below.

**Figure 16:**  
Inventory Command Flags

Flag Bits	Flag Name	Bit Value Meaning	
		0	1
b0	Subcarrier	single subcarrier	double subcarrier
b1	Datarate	low data rate	high data rate
b2	Inventory	x	1 for Inventory
b3	Protocol ext.	always 0	RFU
b4	AFI	Always 0	Not allowed
b5	# of slots	16 slots	1 slot
b6	Option	always 0	RFU
b7	RFU	always 0	RFU

Flags for all other commands are defined in the table below.

**Figure 17:**  
Flags for Other Commands

Flag Bits	Flag Name	Bit Value Meaning	
		0	1
b0	Subcarrier	single subcarrier	double subcarrier
b1	Datarate	low data rate	high data rate
b2	Inventory	0	x
b3	Protocol ext.	always 0	RFU
b4	Select	all tags	selected tag
b5	Address	unaddressed	addressed
b6	Option	always 0	RFU
b7	RFU	always 0	RFU

### Error Handling

Every command request can generate an error response in case an error has been detected. The error response format is the same for all commands:

<b>SOF</b>	<b>FLAGS</b> 8 bits	<b>ERROR CODE</b> 8 bits	<b>CRC</b> 16 bits	<b>EOF</b>
------------	------------------------	-----------------------------	-----------------------	------------

The error codes are defined as below.

**Figure 18:**  
Error Codes

Error Code	Description
0x01	Command not supported - wrong command code
0x02	Command is not recognized - format error
0x03	Option not supported
0x0F	Unknown error
0x10	The specified block is not available
0x11	The specified block is already locked and cannot be locked again
0x12	The specified block is already locked and cannot be written
0xA0	Incorrect password
0xA1	Log parameters missing
0xA2	Battery measurement error
0xA3	Temperature measurement error
0xA5	User data area error
0xA6	EEPROM collision
all other	RFU

### Data Log Format

The SL13A device supports 3 different data log formats. The data log format depends on the Logging form. The data log formats are defined as follows:

Dense mode:

b31 - b30	b29	b20	b19	b10	b9	b0
0	Temp. value 3		Temp. value 2		Temp. value 1	

Limits mode without battery check:

b31	b20	b19	b10	b9	b0
Measurement #		0	Temp. value		

Limits mode with battery check:

b31	b20	b19	b10	b9	b0
Measurement #		Battery value		Temp. value	

In Dense mode there is no Measurement number included, because every measurement is stored to the EEPROM.

The Logging form is set with the Set Log Mode command and is stored in the Bit30 and Bit29 in the Log mode field in the EEPROM.

**Figure 19:**  
Bit30, Bit29

Bit30	Bit29	Logging Form	Description
0	0	Dense	All values are stored to the measurement area. There are 3 10bit temperature values in each EEPROM block. The upper 2 bits are 0. No Battery voltage storage is possible in this mode.
0	1	All values out of limits	All values that are out of the specified limits are stored to the measurement area. There is only 1 measurement in each EEPROM block. The temp. value is in the lower 10 bits (b9 – b0). If Battery check is set to 1, the battery value is stored to the next 10 bits. The upper 12 bits hold the number of the measurement.
1	0	Not allowed	Option not supported
1	1	Limits crossing	Only the crossing point of each limit boundary is stored. There is only 1 measurement in each EEPROM block. The temp. value is in the lower 10 bits (b9 – b0). If Battery check is set to 1, the battery value is stored to the next 10 bits. The upper 12 bits hold the number of the measurement.

## Out-of-Limits Counter

The Out-of-Limits counter can be used as an advanced alarm mechanism. It is enabled in log format with temperature limits and it will display the cumulative number of measurements that are outside the specified limit. The application does not have to read the whole EEPROM content in order to determine if the temperature limits have been exceeded, just the Out-of-Limits block. The Out-of-Limits counter block can be read out with the Get Log State command.

## Logging Timer

The SL13A device has an integrated RC oscillator that is calibrated to 1024Hz. This oscillator drives the logging timer. The logging timer resolution is 1 second, the maximum period is 9.1 hours (32768 seconds).

The measurement real time is derived from 4 parameters - the Start time (ST), the Delay time (DT), the measurement period (MP) and the # of the measurement (NM). This value has to be calculated in the reader by the equation:

$$\text{Real time} = ST + DT + MP * NM$$

## Delay Time

The SL13A supports delayed start of the logging procedure. The Delay time has a resolution of 8.53 minutes and a maximum value of 582 hours (12 bits). The delay time value is set with the Initialize command, while the Delay time counter starts counting when the device receives the Start Log command.

## Temperature Conversion

The calibration data does not have to be included in the temperature conversion equation. The temperature value is calculated as:

$$T(^{\circ}C) = code * 0.169 - 92.7 - 5.4$$

$$LSB = 0.169^{\circ}C$$

$$offset = -92.7^{\circ}C$$

$$offset\ calibration = 0.169 * 32 = 5.4^{\circ}C$$

### Battery Voltage Conversion

The battery voltage conversion is dependent on the initial battery voltage (1.5V or 3V).

For 1.5V battery, the equation is:

$$V = code * 3.35mV + 860mV$$

$$LSB = 3.35mV$$

$$Offset = 860mV$$

For 3V battery:

$$V = code * 6.32mV + 1.62V$$

$$LSB = 6.32mV$$

$$Offset = 1.62V$$

### SPI Operation

Full and unlimited EEPROM access is possible through the SPI interface. The primary function of the SPI interface is production calibration and UID programming, but it can also be used in application, where the ISO15693 interface cannot be used.

Data on the D\_IN pin is latched in on the falling edge of the SCLK signal. Data on the D\_OUT pin is shifted out on the falling edge of the SCLK signal. The bytes are sent MSbit first.

The SPI communication is byte-oriented. It is composed of 3 fields of fixed length: Command field (1 byte), Address field (1 byte) and Data field (4 bytes).

The structure of the Command field is defined in the table below.

**Figure 20:**  
Command Field Structure

Bit Number	Description
b7	EEPROM write
b6	EEPROM read
b5	EEPROM erase
b4	EEPROM write block
b3	EEPROM erase block
b2	Test
b1	RFU
b0	0 - system EEPROM, 1 - user/measurement EEPROM



The Address field holds the EEPROM address. Data field contains the EEPROM data or Test vector.

The SPI communication is always organized into frames of 6 bytes, any other number of bytes will result in a communication error. The communication has to end with a clock pulse - the 'execute' pulse. The whole number of clock pulses in a communication frame is 49.

The only operation that requires more bytes is the EEPROM read operation. After the 49th clock pulse, another 33 clock pulses have to be generated, with a delay of at least 30µs after the 'execute' pulse. The data is shifted out with the last 32 clock pulses.

The SPI supply will send an IRQ on the D\_OUT pin after the command is executed. In the SPI Write command, the D\_OUT signal will go high after the EEPROM write operation is fully completed. This typically takes 12ms. In the SPI Read command, the D\_OUT signal will go high after the data is ready to be read. In order to read the data, the master has to send 1 additional clock pulse – the ACK pulse – before he starts to read the 32 bits of data. In a Read command, the full operation takes 82 clock pulses (48 for command + 1 Execute + 1 ACK + 32 data read).

The SPI interface is referenced to the V<sub>BAT</sub> supply. If the chip is used in fully passive mode with external circuitry, the SPI interface is referenced to the V<sub>EXT</sub> supply.

**Figure 21:**  
**SPI Write Operation**

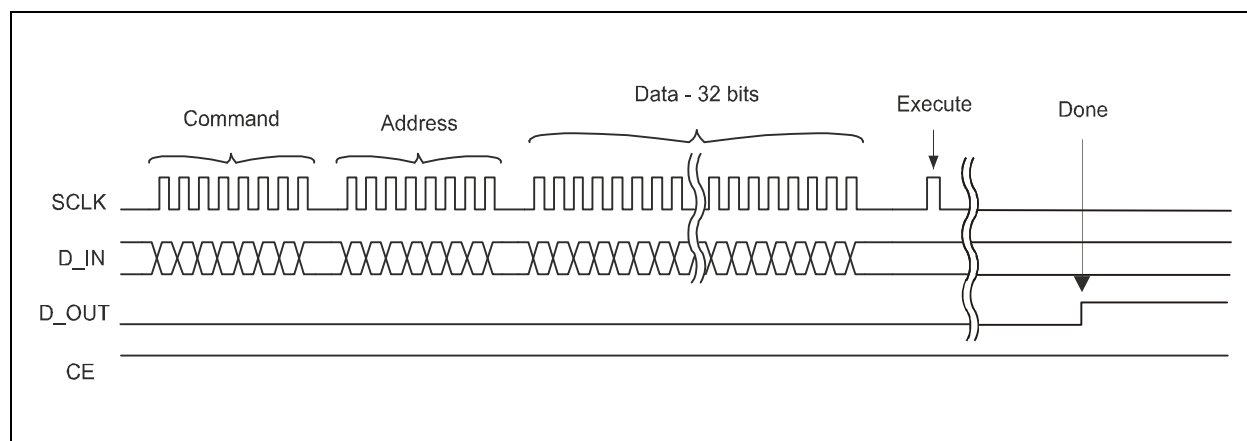

**Figure 22:**  
SPI Read Operation

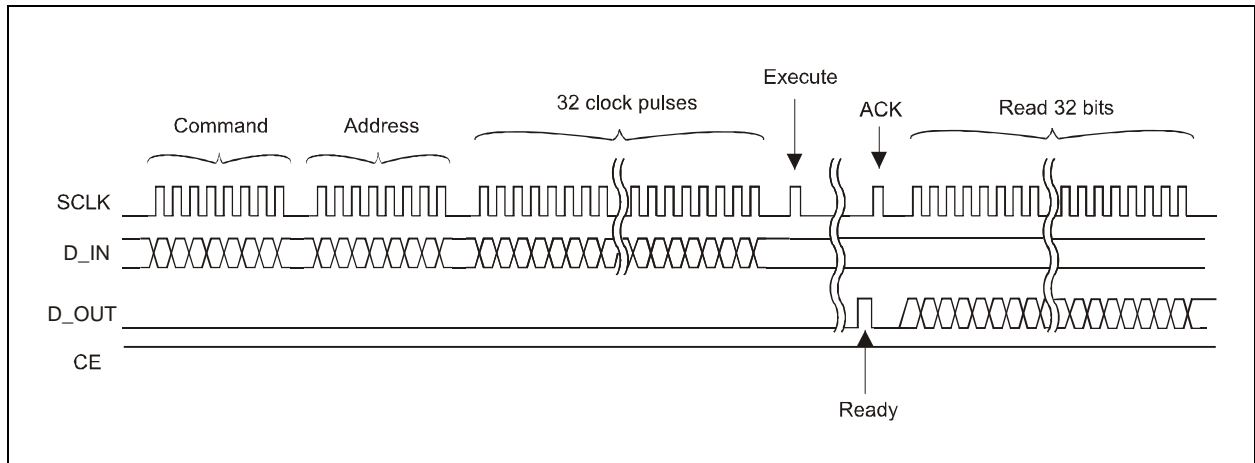

**Figure 23:**  
SPI Enable Procedure

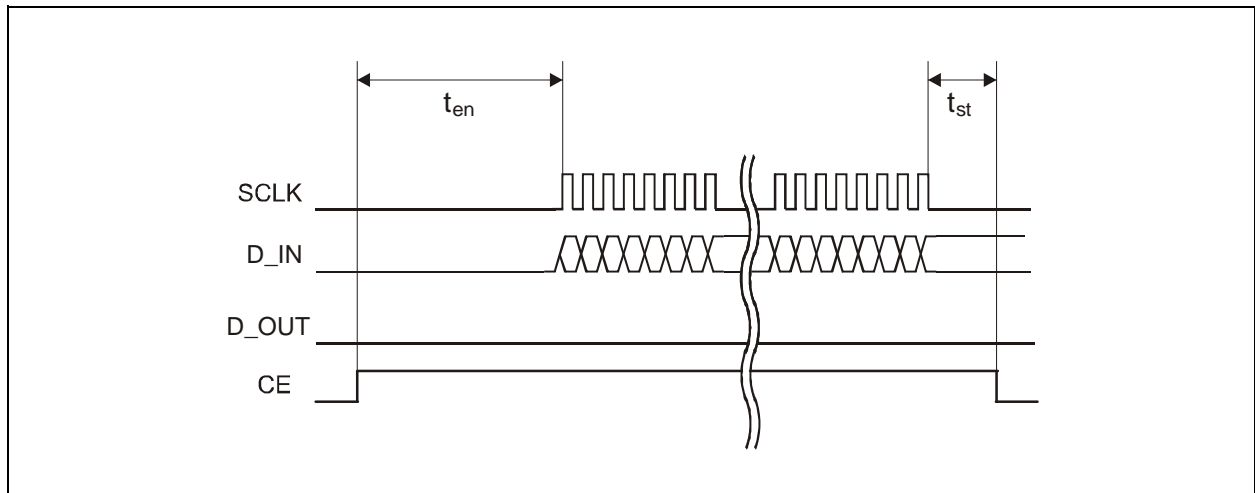

After the CE rising edge the EEPROM supply has to be settled. This happens in 150µs after the rising edge.

**Figure 24:**  
Timing

Time	Value	Description
T <sub>en</sub>	150µs	CE rising edge to SCLK rising edge
T <sub>st</sub>	2 µs	SCLK falling edge to EN falling edge

## Memory Map Overview

Figure 25:  
System Area

Block	Bits	Description
00	00...31	UID lower bits
01	00...31	UID higher bits
02	0 1 2...15 16...23 24...31	AFI/DSFID block DSFID lock bit AFI lock bit TBD DSFID (Data Storage Format Identifier)\ AFI (Application Family Identifier)
03	0...7 8...15 16...23 24...31	Chip info Block size Number of blocks Chip revision number - IC reference TBD
04	0...31	Reserved
05	0...4 5...7 8 9...16 17...18 19 20 21 22 23...24 25 26...31	Internal Calibration data Reference voltage calibration Bandgap reference calibration Reference voltage calibration MSB1 RTC oscillator calibration Low POR calibration - 1.5V battery Enable battery voltage switch to CE pin High POR calibration - 3V battery Bandgap reference calibration LSB TBD 3MHz oscillator calibration Reference voltage calibration MSB2 A/D offset calibration
06	0...31	External calibration data
07	0...31	Reserved
08	0...5 6...11 12...16 17...21 22...25 26...31	Start time - suggested Start time format (YYYY-MM-DD-hh:mm:ss) second minute hour day month year
09	0...9 10...19 20...29 30...31	Limits Extreme lower limit Lower limit Upper limit TBD

Block	Bits	Description
0A	0...9 10...24 25 26 27 28 29...30 31	Log mode + limits Extreme upper limit Log interval (LSB=1 second, maximum=32768 seconds) reserved TBD Storage rule (0 - normal, 1 - rolling) Battery check (0 - no battery measurement, 1 - battery measurement at logging) Logging form Internal/external sensor (0 - internal temp. sensor, 1 - external sensor)
0B	0...7 8...19 20...30 31	Number of blocks for user data Delay time (LSB=8.53 minutes, maximum=582hours) TBD Single use flag (0 - reusable, 1 - single use/secure)
0C	0 1...10 11...13 14...23 24...31	Memory/Measurement status Active (0 - passive, 1 - active/logging) Errors and events Number of memory replacements Number of measurements Measurement address pointer
0D	0...31	<b>Password for System area</b> (password 1)
0E	0...31	<b>Password for User area</b> (password 2)
0F	0...31	<b>Password for Measurement area</b> (password 3)
10 - 17	0...31	Lock bits for User/Measurement area
18	0...7 8...15 16...23 24...31	Out of limits counter Extreme lower limit counter Lower limit counter Higher limit counter Extreme higher limit counter
18 - 1F	0...31	Reserved

**Figure 26:**  
**User and Measurement Area**

Block	Bits	Description
00	00...31	Reserved for user data – no password protection
01 - FF	00...31	User or measurement data

## Temperature Performance

The following graph shows the temperature conversion nonlinearity of 8 SL13A devices.

**Figure 27:**  
Integral Nonlinearity Graph

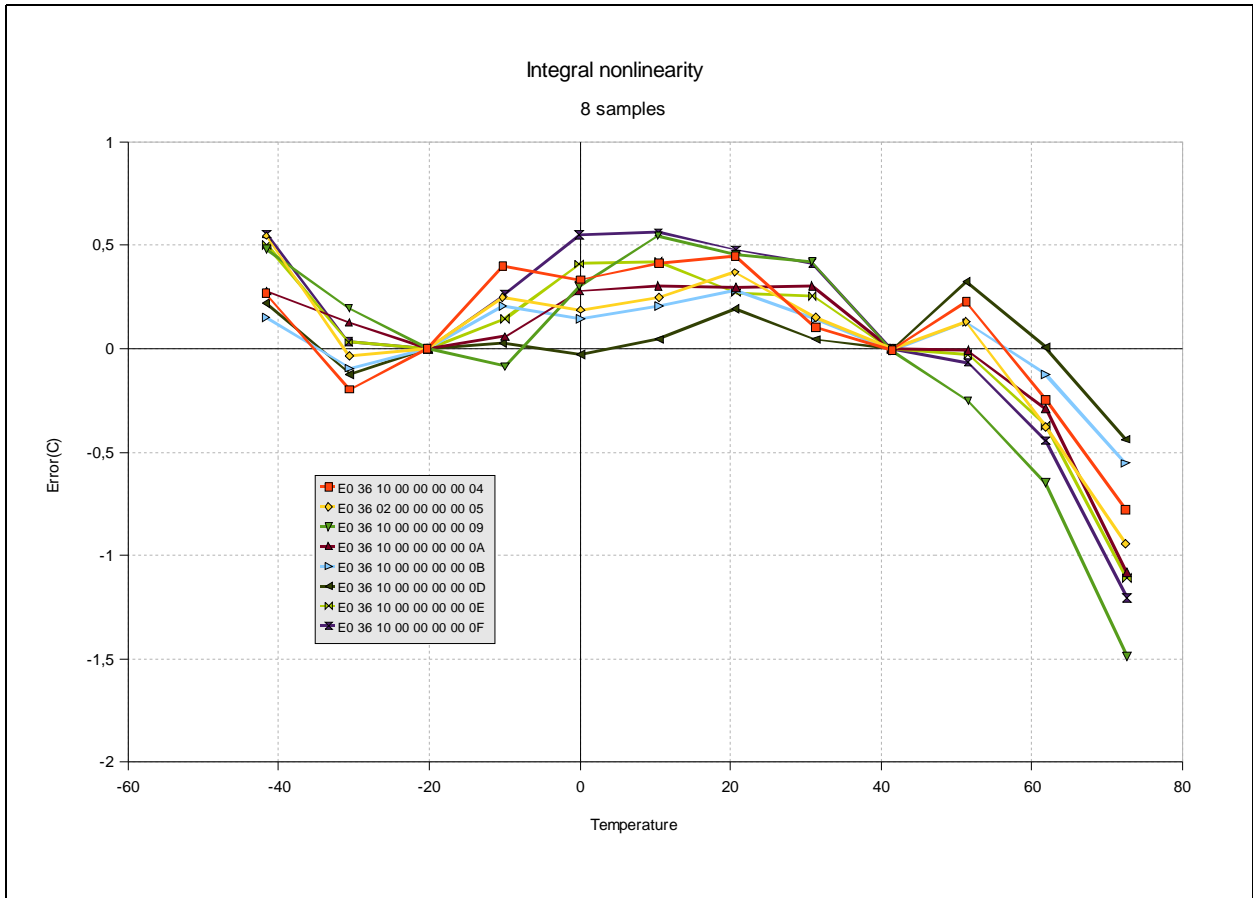

The measurements have been performed on the following equipment:

- Environmental chamber: ESPEC SU-241
- Reference temperature sensor: Testo 735 (system accuracy of 0.05°C)
- Reference temperature probe: Testo High accuracy Pt100 probe (0614 0235)

For each temperature point, 100 measurements were taken using the logging function of the SL13A chip. The RF field of the reader has been turned off during the temperature logging.

**Applications**

**Typical Application**

Figure 28 shows a typical application with a 1.5V battery, an antenna coil and an optional external sensor module (semi-passive mode).

Such application is typically used for automatic data logging from on-chip temperature sensor or an external sensor connected to  $S_{EXT}$ .

The chip can store up to 762 measurement points. The intervals between measurements as well as the limits are programmable. It is possible to store all measuring points, or only the measurements, which are outside predefined limits.

**Figure 28:**  
**Typical Application**

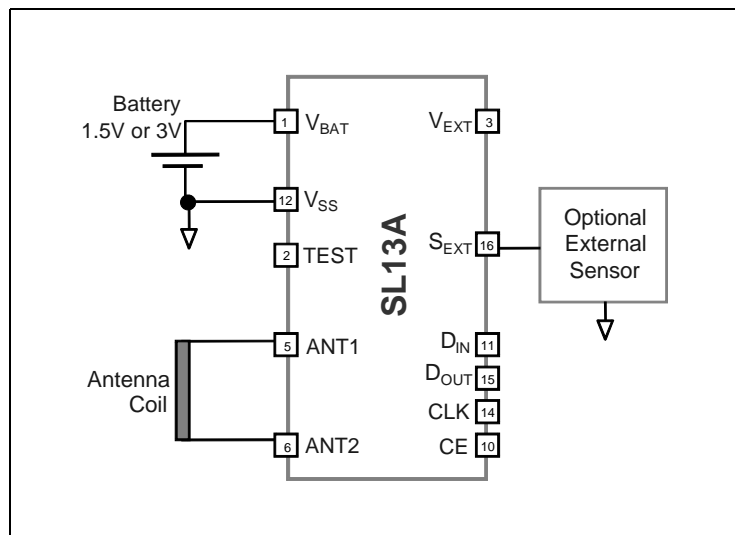

### Passive Mode

Figure 29 shows a typical application without battery (passive mode).

The SL13A chip also works in passive mode with no battery, without the real-time clock function. This approach is intended for applications in which a reader initiates the logging and time-stamps the logging data.

The chip controls whether it takes data from internal or external sensors. Access to the smart label chip is protected through a 3-level password authentication. Users can add other types of external sensors to monitor shock control, humidity, or other factors.

**Figure 29:**  
Typical Passive Mode Application

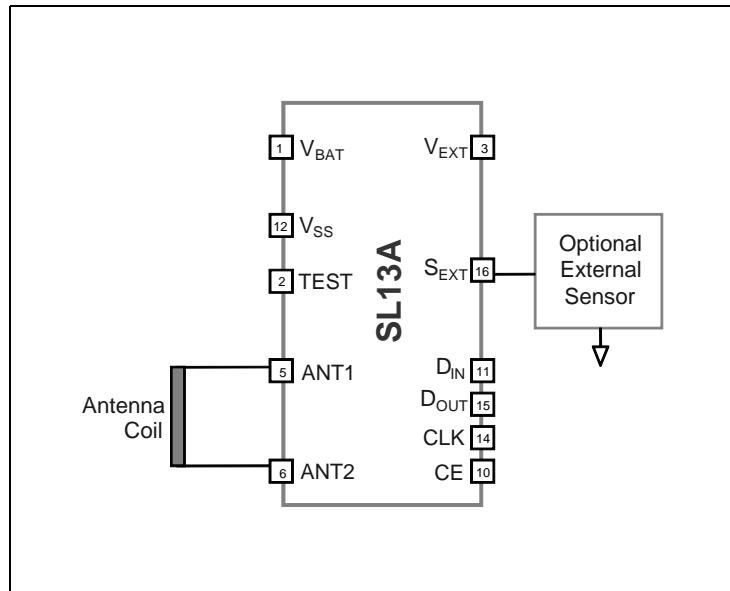

### SPI Communication

Figure 30 shows an application using the SPI interface to communicate with other circuitries.

The Serial Peripheral Interface (SPI) port can be connected to external circuitries for display etc.; this allows further communication between the chip and other circuits such as a wireless transceiver for remote direct access to the logging data and for easy setting of parameters and functions. The chip supports an alarm system and functions that calculate shelf life.

Such applications are possible in both passive and semi-passive mode. In passive mode, the chip provides a supply current of maximum 4 mA from the  $V_{EXT}$  assuming a reader provides sufficient power from its field. The  $V_{EXT}$  voltage is limited at 3.4V.

**Figure 30:**  
Application with SPI Communication

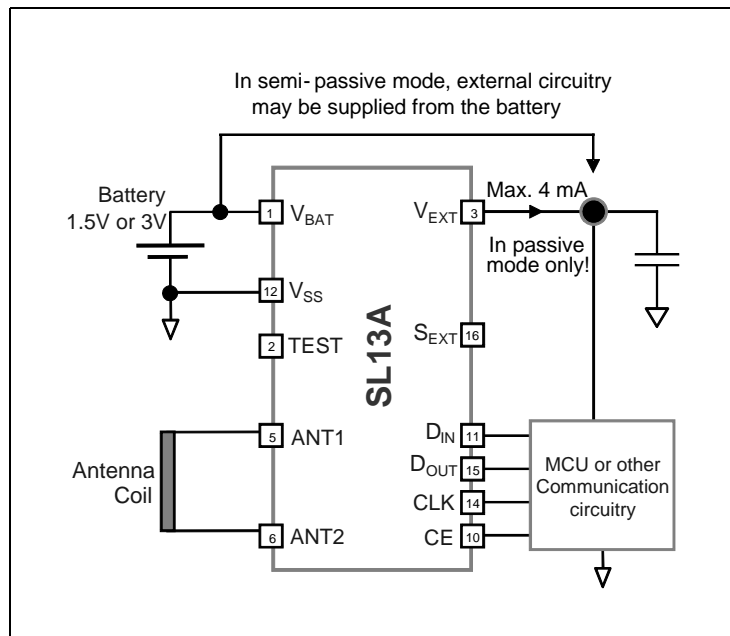



### Packaging Information

Figure 31:  
Package Drawings

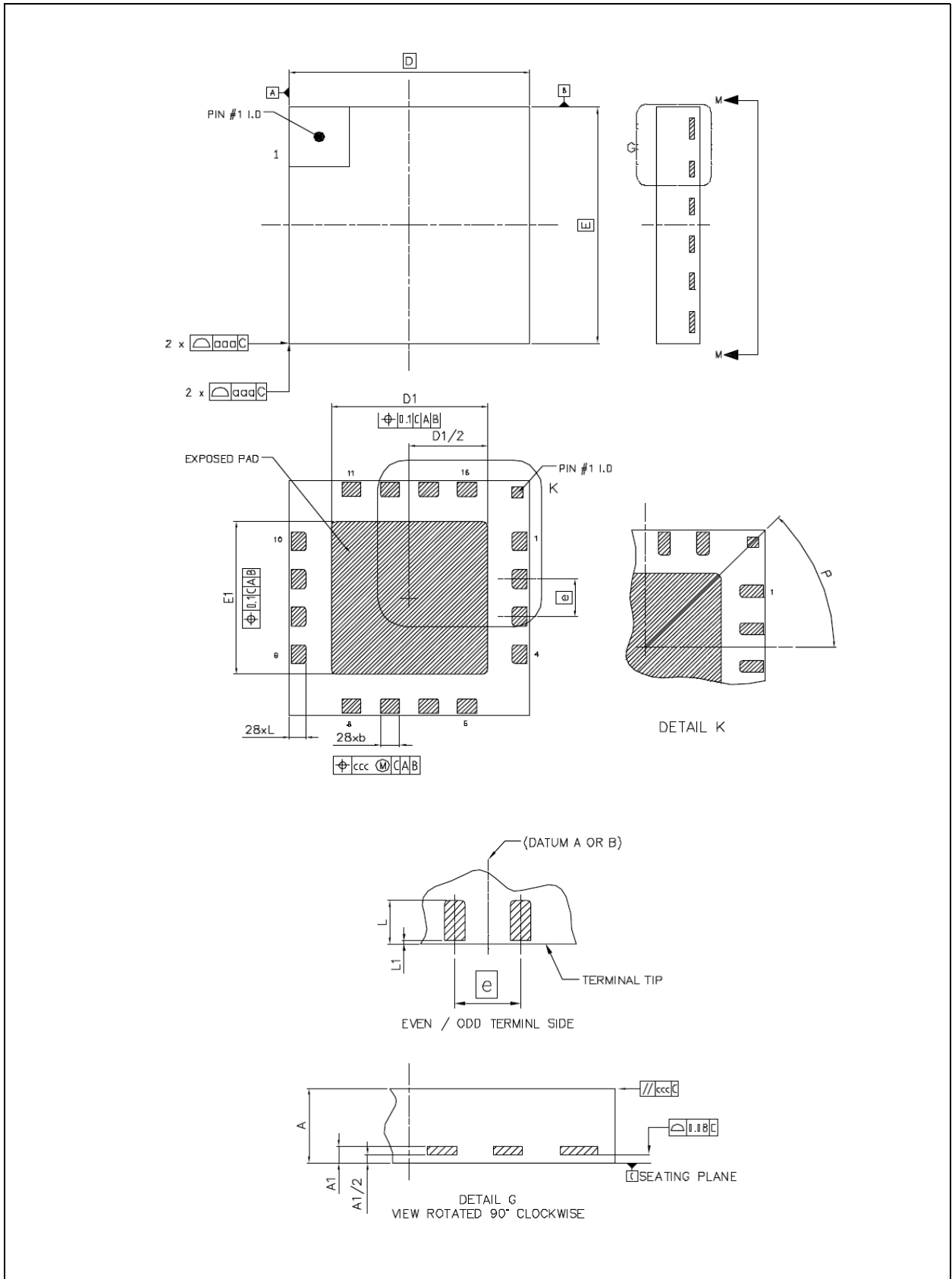

**Figure 32:  
Dimensions**

Dim	Min	Nom	Max	Notes
A	0.80	0.90	1.00	1. Dimensioning and tolerancing confirm to ASME Y14.5M-1994. 2. All dimensions are in millimeters. Angles are in degrees. 3. Dimension b applies to metallized terminal and is measured between 0.25mm and 0.30mm from terminal tip. Dimension L1 represents terminal full back from package edge up to 0.1mm is acceptable. 4. Coplanarity applies to the exposed heat slug as well as the terminal. 5. Radius on terminal is optional.
A1	0.203 REF			
b	0.33	0.40	0.47	
D	5.00 BSC			
E	5.00 BSC			
D1	3.15	3.25	3.35	
E1	3.15	3.25	3.35	
e	-	0.80 BSC	-	
L	0.255	0.355	0.455	
L1			0.10	
P	45° BSC			
aaa		0.10		
ccc		0.10		

**Note(s) and/or Footnote(s):**

1. The reflow peak soldering temperature (body temperature) is specified according IPC/JEDEC J-STD-020C "Moisture/Reflow Sensitivity Classification for Non-hermetic Solid State Surface Mount Devices".

## Ordering & Contact Information

**Figure 33:**  
Ordering Information

Ordering Code	Description	Operating Temperature Range	Package Type	Device Marking	Shipping Form
SL13A-AQFT	Smart active label IC with on-chip temperature sensor and 8k EEPROM	-40°C to 110°C	QFN 16LD (5x5 mm) RoHS <sup>(1)</sup>	SL13A	Tape & reel 1,000 parts/13" reel
SL13A-ASWB		-40°C to 110°C	-		Tested wafers

**Note(s) and/or Footnote(s):**

1. Pb-Free (RoHS compatible), and free of Bromine (Br) and Antimony (Sb) based flame retardants (Br or Sb do not exceed 0.1% by weight in homogeneous material).
2. The tested wafers are not physical inked but are delivered with a wafer map specification in Electroglas format.
3. Order quantities should be a multiple of shipping form.

Buy our products or get free samples online at:

[www.ams.com/ICdirect](http://www.ams.com/ICdirect)

Technical Support is available at:

[www.ams.com/Technical-Support](http://www.ams.com/Technical-Support)

For further information and requests, e-mail us at:

[ams\\_sales@ams.com](mailto:ams_sales@ams.com)

For sales offices, distributors and representatives, please visit:

[www.ams.com/contact](http://www.ams.com/contact)

**Headquarters**

ams AG  
Tobelbaderstrasse 30  
8141 Unterpremstaetten  
Austria, Europe

Tel: +43 (0) 3136 500 0

Website: [www.ams.com](http://www.ams.com)

## RoHS Compliant & ams Green Statement

**RoHS:** The term RoHS compliant means that ams AG products fully comply with current RoHS directives. Our semiconductor products do not contain any chemicals for all 6 substance categories, including the requirement that lead not exceed 0.1% by weight in homogeneous materials. Where designed to be soldered at high temperatures, RoHS compliant products are suitable for use in specified lead-free processes.

**ams Green (RoHS compliant and no Sb/Br):** ams Green defines that in addition to RoHS compliance, our products are free of Bromine (Br) and Antimony (Sb) based flame retardants (Br or Sb do not exceed 0.1% by weight in homogeneous material).

**Important Information:** The information provided in this statement represents ams AG knowledge and belief as of the date that it is provided. ams AG bases its knowledge and belief on information provided by third parties, and makes no representation or warranty as to the accuracy of such information. Efforts are underway to better integrate information from third parties. ams AG has taken and continues to take reasonable steps to provide representative and accurate information but may not have conducted destructive testing or chemical analysis on incoming materials and chemicals. ams AG and ams AG suppliers consider certain information to be proprietary, and thus CAS numbers and other limited information may not be available for release.

## Copyrights & Disclaimer

Copyright ams AG, Tobelbader Strasse 30, 8141 Unterpremstaetten, Austria-Europe. Trademarks Registered. All rights reserved. The material herein may not be reproduced, adapted, merged, translated, stored, or used without the prior written consent of the copyright owner.

Devices sold by ams AG are covered by the warranty and patent indemnification provisions appearing in its Terms of Sale. ams AG makes no warranty, express, statutory, implied, or by description regarding the information set forth herein. ams AG reserves the right to change specifications and prices at any time and without notice. Therefore, prior to designing this product into a system, it is necessary to check with ams AG for current information. This product is intended for use in commercial applications. Applications requiring extended temperature range, unusual environmental requirements, or high reliability applications, such as military, medical life-support or life-sustaining equipment are specifically not recommended without additional processing by ams AG for each application. This product is provided by ams AG "AS IS" and any express or implied warranties, including, but not limited to the implied warranties of merchantability and fitness for a particular purpose are disclaimed.

ams AG shall not be liable to recipient or any third party for any damages, including but not limited to personal injury, property damage, loss of profits, loss of use, interruption of business or indirect, special, incidental or consequential damages, of any kind, in connection with or arising out of the furnishing, performance or use of the technical data herein. No obligation or liability to recipient or any third party shall arise or flow out of ams AG rendering of technical or other services.

## Document Status

Document Status	Product Status	Definition
Product Preview	Pre-Development	Information in this datasheet is based on product ideas in the planning phase of development. All specifications are design goals without any warranty and are subject to change without notice
Preliminary Datasheet	Pre-Production	Information in this datasheet is based on products in the design, validation or qualification phase of development. The performance and parameters shown in this document are preliminary without any warranty and are subject to change without notice
Datasheet	Production	Information in this datasheet is based on products in ramp-up to full production or full production which conform to specifications in accordance with the terms of ams AG standard warranty as given in the General Terms of Trade
Datasheet (discontinued)	Discontinued	Information in this datasheet is based on products which conform to specifications in accordance with the terms of ams AG standard warranty as given in the General Terms of Trade, but these products have been superseded and should not be used for new designs

## Revision Information

Changes from 1-00 (2014-Mar) to current revision 1-01 (2014-May-06)	Page
Removed "Confidential" from the footer	
Updated Figure 8	6

**Note(s) and/or Footnote(s):**

1. Page numbers for the previous version may differ from page numbers in the current revision

**Content Guide**

- 1 General Description**
  - 1 Key Benefits & Features
  - 2 Applications
  - 2 Block Diagram
  
- 3 Pin and Pad Layout**
- 5 Absolute Maximum Ratings**
- 5 Operating Conditions**
- 6 Electrical Characteristics**
  
- 8 Detailed Description**
  - 8 Supply Arrangement
  - 8 Analog Front End (AFE)
  - 9 Processing and Digital Control
  - 9 Serial Interface (SPI)
  - 9 Real-Time Clock (RTC)
  - 9 Temperature Sensor
  - 9 External Sensor
  - 10 A/D Converter
  - 10 EEPROM Organization and Security
  - 10 Fully Passive Operation
  
- 11 Functional Description**
  - 11 Initializing the Chip
  - 11 Ready State
  - 11 Active State
  - 11 Logging State
  - 12 Passive State
  
- 13 State Diagram**
  
- 13 Commands**
  - 13 Request Command Structure
  - 14 Response Structure
  - 16 Command Description
    - 19 Inventory - #01
    - 19 Stay Quiet - #02
    - 20 Read Block - #03
    - 20 Read Blocks - #04
    - 20 Write Block - #05
    - 20 Lock Block - #06
    - 21 Write AFI - #07
    - 21 Lock AFI - #08
    - 21 Write DSFID - #09
    - 22 Lock DSFID - #10
    - 22 Reset to Ready - #11
    - 22 Get System Info - #12
    - 23 Set Password - #13
    - 23 Set Log Mode - #14
    - 24 Set Log Limits - #15
    - 24 Get Measurement Setup - #16
    - 24 Set External Calibration Data - #17
    - 25 Set Internal Calibration Data - #18
    - 25 Set Passive - #19



25	Start Log - #20
26	Get Log State - #21
26	Get Calibration Data - #22
26	Get Battery Level - #23
27	Verify Password - #24
27	Initialize - #25
27	Get Temperature - #26
28	Flags
29	Error Handling
30	Data Log Format
31	Out-of-Limits Counter
31	Logging Timer
31	Delay Time
31	Temperature Conversion
32	Battery Voltage Conversion
32	SPI Operation
<b>35</b>	<b>Memory Map Overview</b>
<b>37</b>	<b>Temperature Performance</b>
<b>38</b>	<b>Applications</b>
38	Typical Application
39	Passive Mode
40	SPI Communication
<b>41</b>	<b>Packaging Information</b>
<b>43</b>	<b>Ordering &amp; Contact Information</b>
<b>44</b>	<b>RoHS Compliant &amp; ams Green Statement</b>
<b>45</b>	<b>Copyrights &amp; Disclaimer</b>
<b>46</b>	<b>Document Status</b>
<b>47</b>	<b>Revision Information</b>

# Mouser Electronics

Authorized Distributor

Click to View Pricing, Inventory, Delivery & Lifecycle Information:

[ams:](#)

[SL13A-AQFM](#)