

NOTES:

1. MATERIAL AND FLAMMABILITY.
 POLYCARBONATE (LIGHT GRAY AND CLEAR) - UL94-HB
 BODY, COVER AND CLEAR COVER (C)
 FLAMMABILITY RATING (UL FILE #E41613)
 SERVICE TEMPERATURE RANGE: -40°C TO +120°C
2. UL 508A (E352997) UL CERT OF COMPLIANCE.: BOXES UL LISTED
 NEMA TYPE 6P STANDARD. DESIGNED MEETS IP68 OF IEC529
 REQUIREMENTS. PC VERSION UV RESISTANT FOR OUT DOOR USE.
3. GASKET (NOT INSTALLED) MOLDED SILICONE WHITE
4. DIMENSIONS ARE INCH

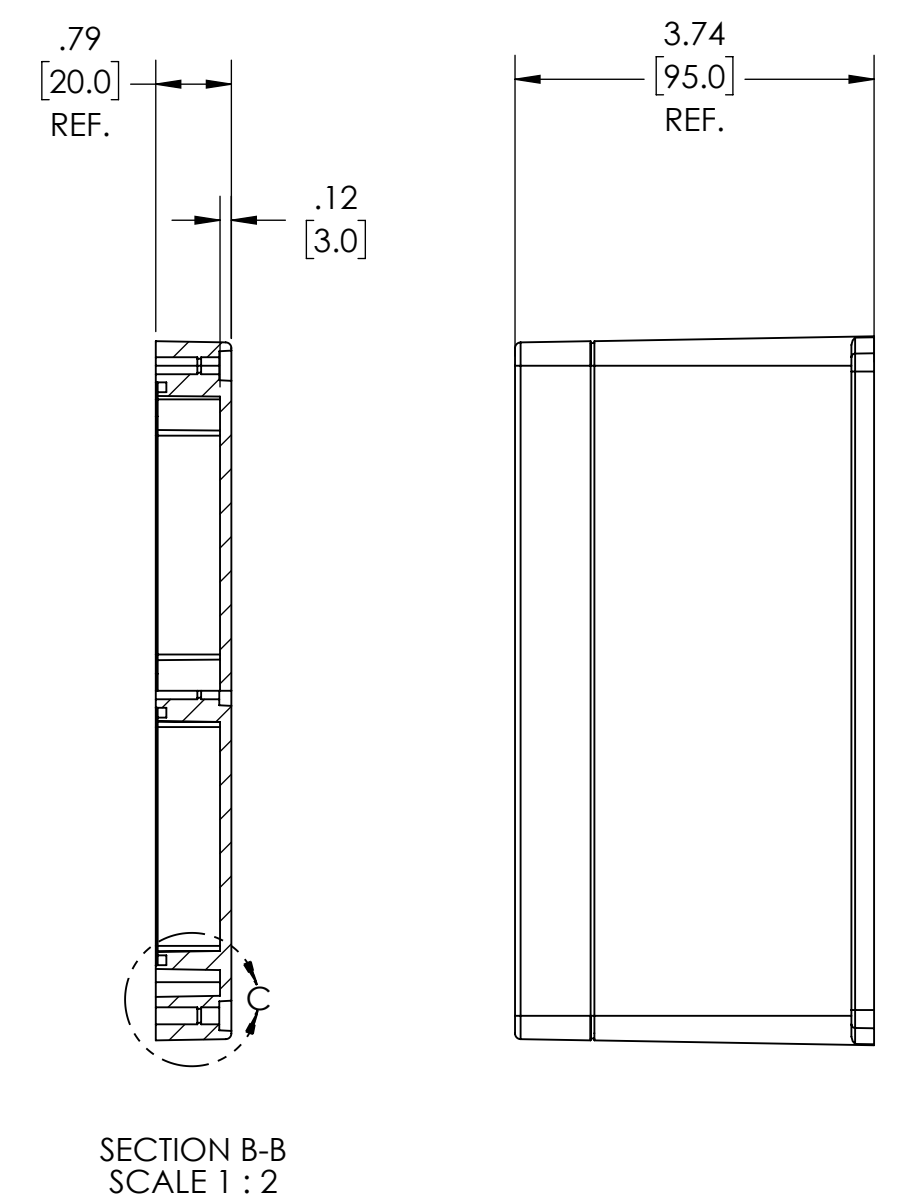
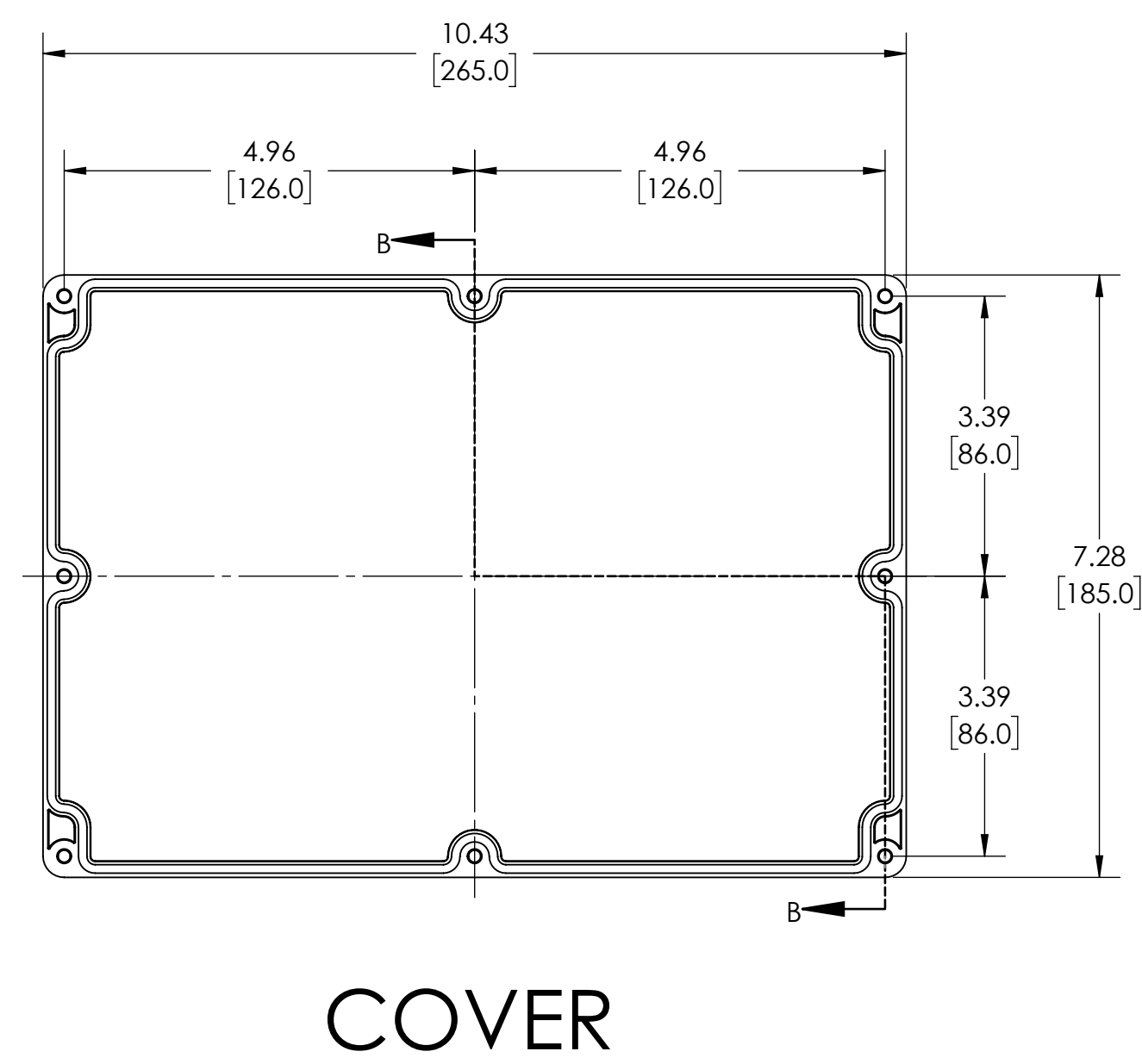
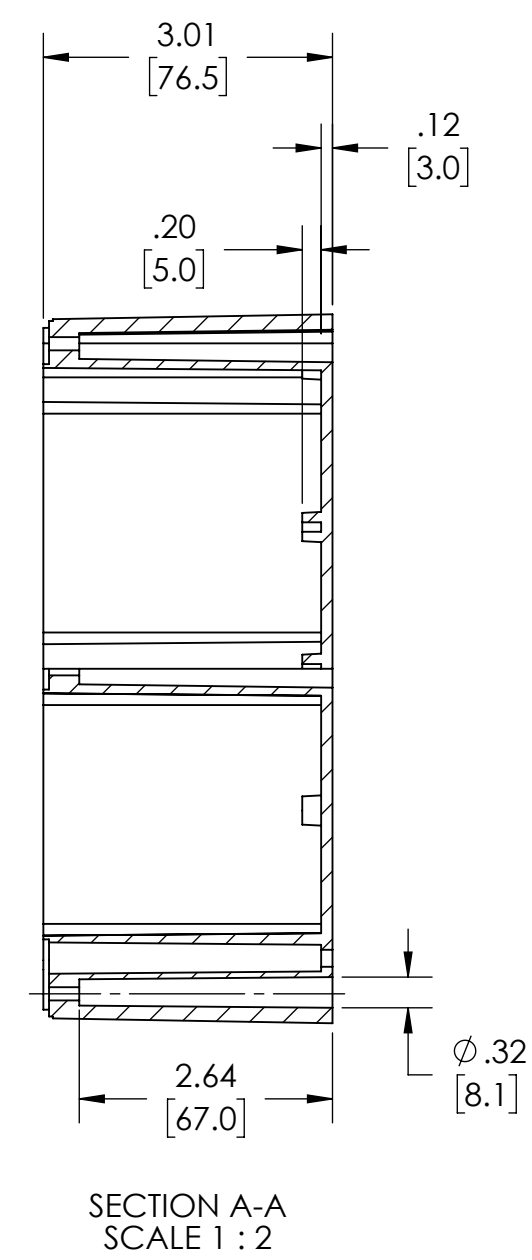
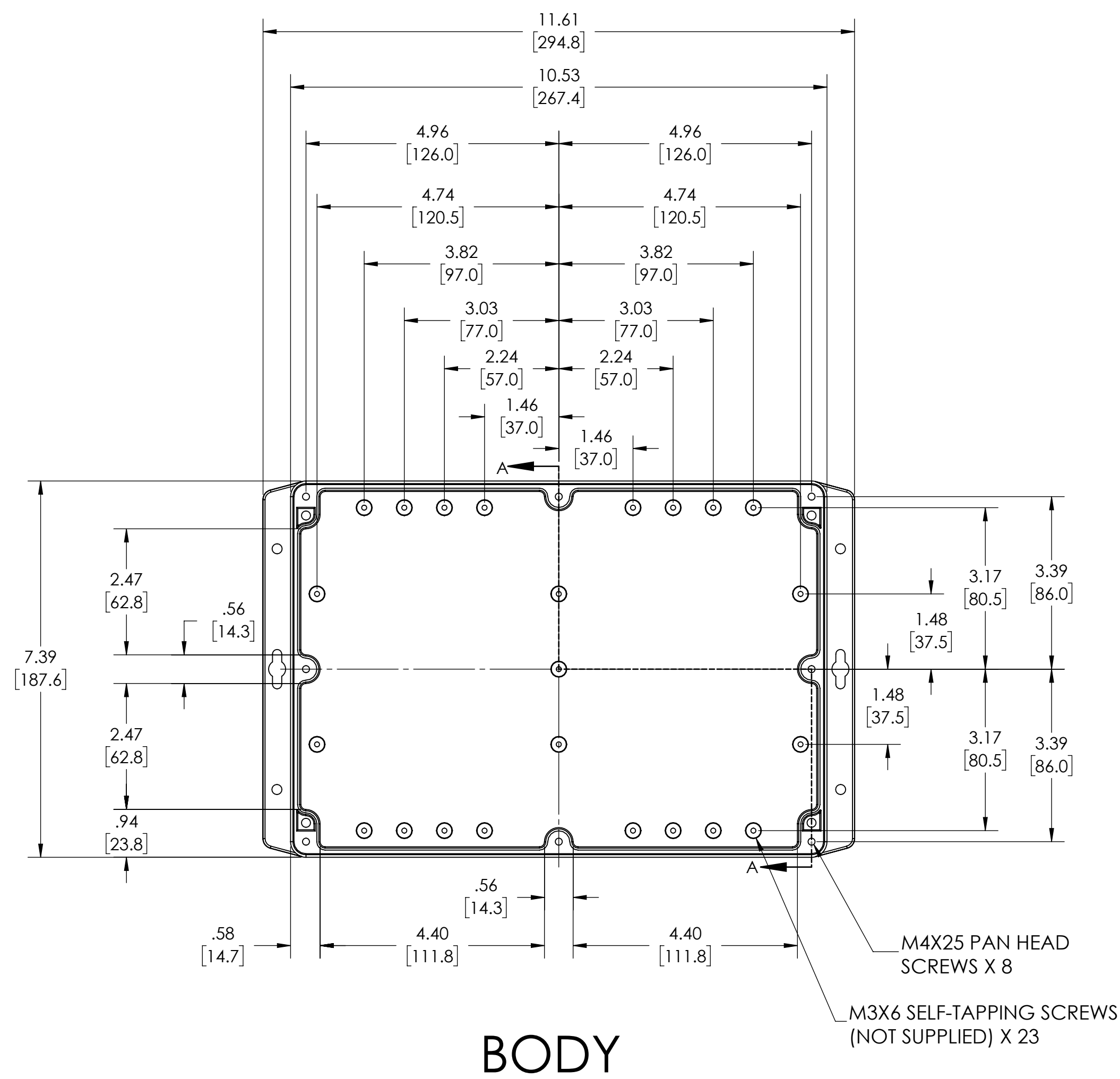
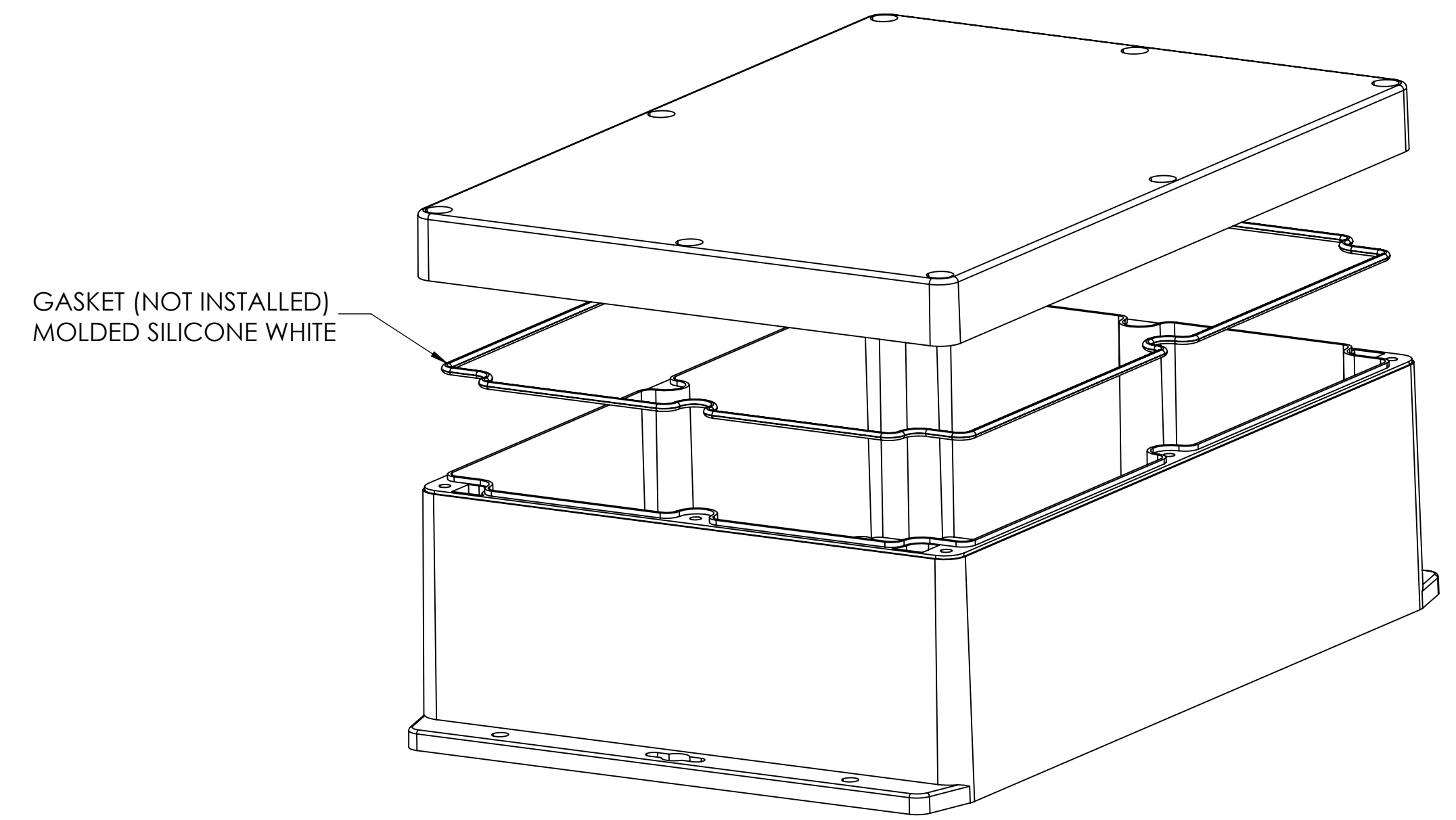
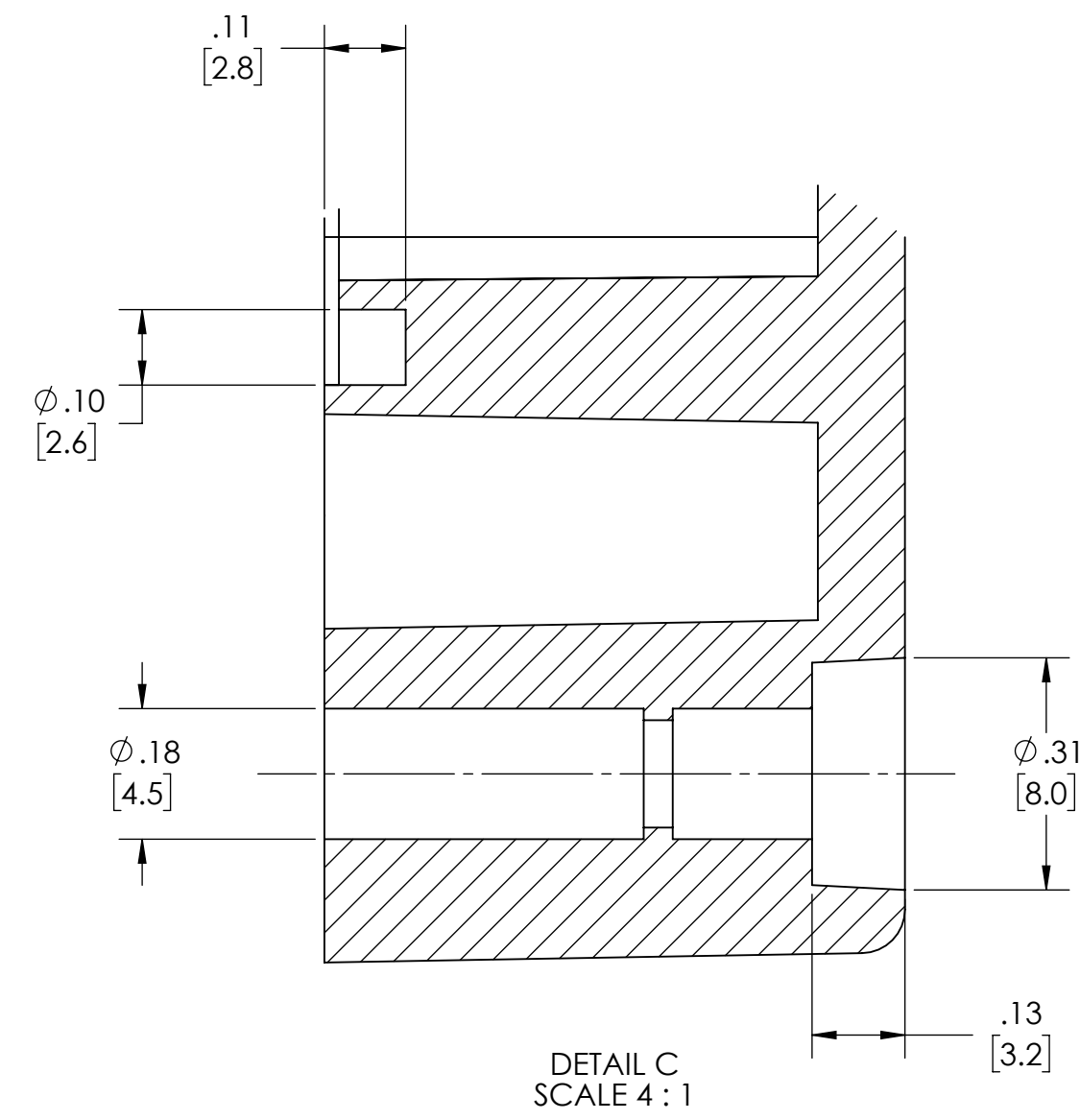

DRAWING FOR REFERENCE
 WE RESERVE THE RIGHT TO MAKE CHANGES TO OUR
 STANDARD PRODUCTS. PLEASE CONSULT WITH BUD INDUSTRIES
 PRIOR TO USING THIS DRAWING FOR DESIGN PURPOSE.

Mouser Electronics

Authorized Distributor

Click to View Pricing, Inventory, Delivery & Lifecycle Information:

[Bud Industries:](#)

[PN-1335-AMB](#)