



PART NAME

EXTERNAL BRACKETS KIT

PART No.

MTX-6512

REV. DATE

10-27-15

DRAWING FOR REFERENCE

WE RESERVE THE RIGHT TO MAKE CHANGES TO OUR STANDARD PRODUCTS. PLEASE CONSULT WITH BUD INDUSTRIES PRIOR TO USING THIS DRAWING FOR DESIGN PURPOSE.

MATERIAL: STAINLESS STEEL 304

FINISH: NATURAL

DIMENSIONS IN INCH [MM]

KIT CONSISTS OF THE FOLLOWING ITEMS:

- QTY. (4) BRACKETS
- QTY. (4) M6 SCREWS
- QTY. (4) M6 FLAT WASHERS
- QTY. (4) M6 SPLIT LOCKWASHERS

WILL FIT THE FOLLOWING ENCLOSURES:

- #ATX-10505
- #ATX-10506
- #ATX-10507
- #ATX-10509
- #ATX-10510
- #ATX-10512
- #ATX-10515
- #ATX-10519

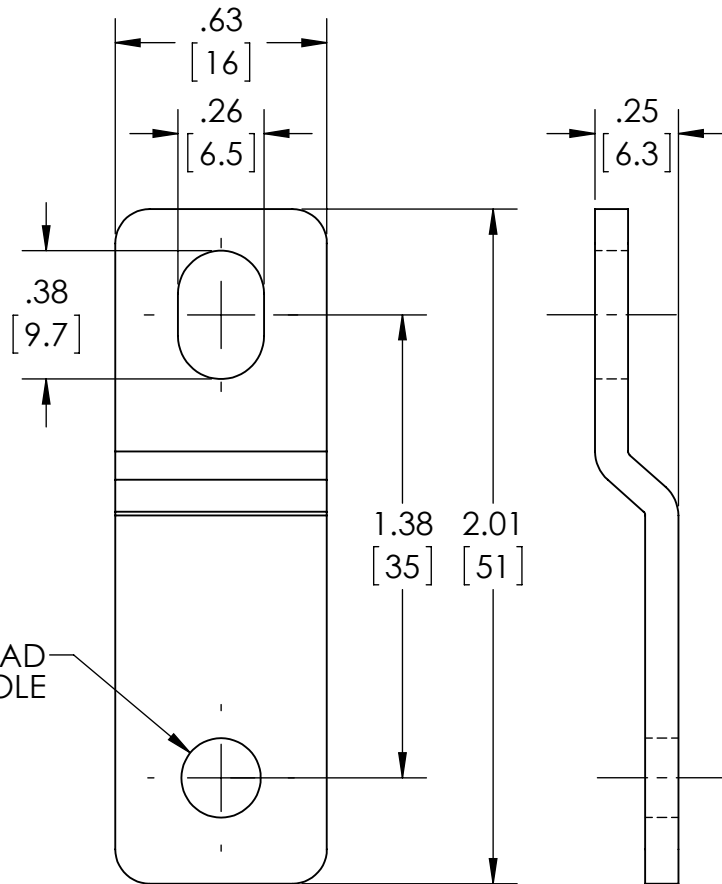

M6 THREAD HOLE

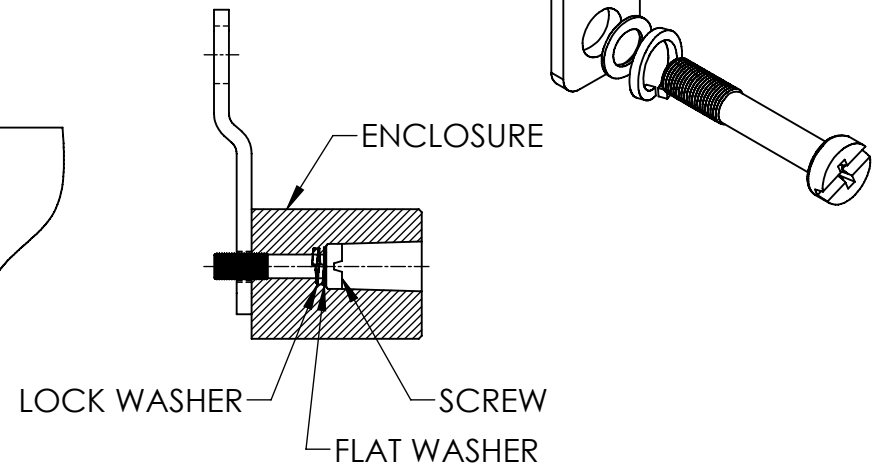
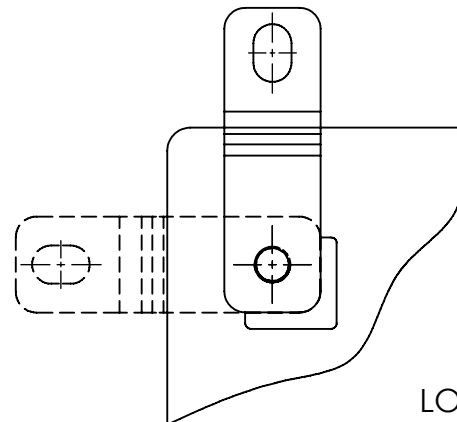

Mouser Electronics

Authorized Distributor

Click to View Pricing, Inventory, Delivery & Lifecycle Information:

[Bud Industries:](#)

[MTX-6512](#)