

8 7 6 5 4 3 2 1

This document, including the design, configuration and mechanical features revealed herein are the sole, confidential and proprietary property of Winchester Interconnect. Reproduction or use thereof, in whole or part, is prohibited without the prior written consent of Winchester Interconnect.

REV	DESCRIPTION	DATE	APPD
C	ER072316	02/09/18	DCAM
D	ECO-12605	07/13/20	LA
E	ECO-12719	08/05/20	LA

NOTES: UNLESS OTHERWISE SPECIFIED
 1. INTERFACE PER MIL-STD-348,SERIES N,PIN CONTACT .

2. MATERIAL SPECIFICATIONS:
 BODY,CLAMP BODY AND NUT: STAINLESS STEEL PER ASTM A582
 INSULATOR: TEFLON PER ASTM D1710
 GASKET: SILICONE RUBBER PER A-A-59588
 RETAINING RING: PHOSPHOR BRONZE PER ASTM B103
 REAR INSULATOR: PCPFE (KEL F)
 SOLDER SLEEVE,CENTER CONTACT: BRASS PER ASTM B16

3. FINISH SPECIFICATIONS:
 RETAINING RING: .000050 MIN NICKEL PER AMS-QQ-N-290
 OVER .000050 MIN COPPER PER ASTM B734
 BODY & NUT & CLAMP BODY: PASSIVATE PER ASTM A967
 CENTER CONTACT: .000050 MIN GOLD PER ASTM B488 OVER
 .000050 MIN NICKEL PER AMS-QQ-N-290
 SOLDER SLEEVE: .000015 MIN GOLD PER ASTM B488 OVER .000080 MIN NICKEL
 PER AMS-QQ-N-290

4. ELECTRICAL SPECIFICATIONS:
 IMPEDANCE: 50 OHMS
 FREQUENCY RANGE: DC TO 18GHz
 VOLTAGE RATING: 1000 VOLTS RMS
 VSWR: 1.175 MAX
 INSERTION LOSS: .035 X $\sqrt{f(\text{GHz})}$ dB MAX

5. CONTACT, REAR INSULATOR, CLAMP NUT, GASKET AND SOLDER SLEEVE SHIPPED LOOSE.

6. DESIGNED FOR USE WITH 1W 1803 CABLE.

7. ASSEMBLE TO CABLE USING CABLING PROCEDURE CAP 6-11.

8. CONNECTOR MEETS REQUIREMENTS OF THE DEFENSE FEDERAL ACQUISITION REGULATION AS STATED IN CLAUSE 252.225-7014, ALTERNATIVE 1.

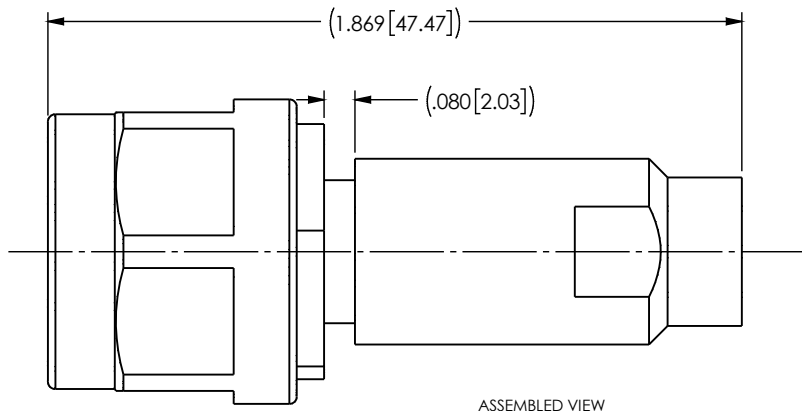

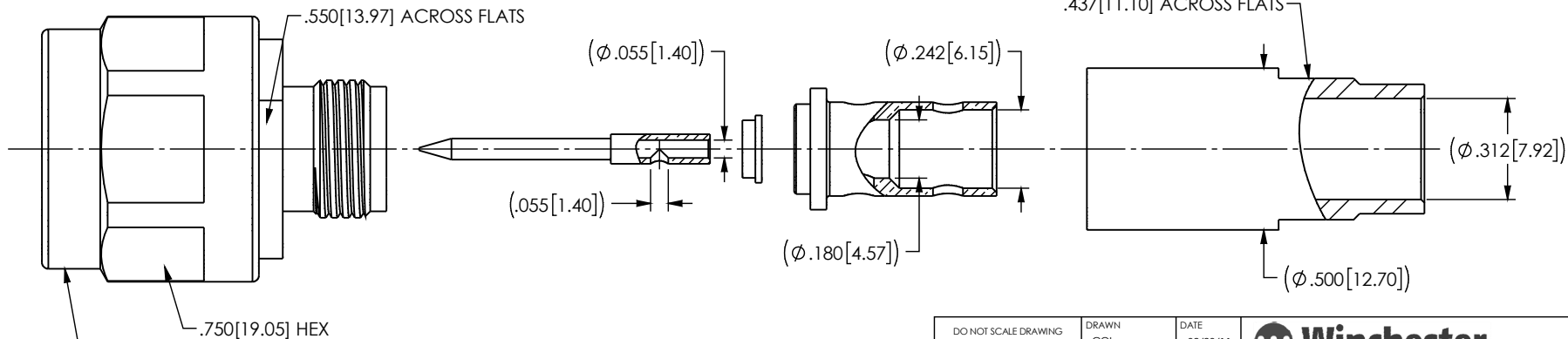

ASSEMBLED VIEW



.750[19.05] HEX

MARK: KINGS

CATALOG P/N: 3395-600-W1901P

DO NOT SCALE DRAWING	DRAWN COL	DATE 02/20/11	 245 Lynnfield St. Peabody, MA 01960		
UNLESS OTHERWISE SPECIFIED: DIMENSIONS ARE IN INCHES	ENG APPR. DCAM	DATE 02/23/12			
	MFG APPR.	DATE			
	OTHER APPR.	DATE			
TOLERANCES: FRACTIONS: $\pm 1/64$.XX: $\pm .01$.XXX: $\pm .005$ ANGLES: $\pm 1/2'$ MACHINED SURFACES: $63/\checkmark$			TITLE: STRAIGHT CABLE PLUG ASSY		
THIRD ANGLE PROJECTION			SIZE B	DWG. NO. SD3395-600-W1901P	REV E
PER ASME Y14.5M-1994		SCALE: 1:1	SHEET 1 OF 1		

8 7 6 5 4 3 2 1

Mouser Electronics

Authorized Distributor

Click to View Pricing, Inventory, Delivery & Lifecycle Information:

[Winchester Interconnect:](#)

[3395-600-W1901P](#)